

V. N. Swane

American Railway Signaling Principles and Practices

CHAPTER XIII

Light Signals and Light Signal Lamps

Published by the Signal Section, A. A. R.

30 Vesey Street, New York 7, N. Y.

REVISED FEBRUARY 1949

American Railway Signaling

Principles and Practices

CHAPTER XIII

Light Signals and Light Signal Lamps

REVISED FEBRUARY 1949

PUBLISHED BY
ASSOCIATION OF AMERICAN RAILROADS, SIGNAL SECTION
30 VESEY STREET, NEW YORK 7, N. Y.

COPYRIGHT, 1949, BY
ASSOCIATION OF AMERICAN RAILROADS, SIGNAL SECTION
(PRINTED IN THE UNITED STATES OF AMERICA)

CHAPTER XIII

LIGHT SIGNALS AND LIGHT SIGNAL LAMPS

Historical.

The semaphore signal has served its purpose very well, but it had its limitations, due to height, length of arms and moving parts. Its practical use was further complicated in that two entirely different aspects were used, one by day and the other by night. An effort was made to devise some arrangement whereby the same aspects could be displayed both day and night. Originally this effort was along the lines of illuminating the semaphore arm to make it visible at night rather than make the colored lights visible during the day, due chiefly to the limitations of oil lamps.

With improved methods of producing electric lamps, renewed efforts were made to solve the matter of uniform day and night signaling. Also the necessity of signals for tunnels and subways began to present itself and a light signal was developed in 1904 to take care of an installation in the East Boston Tunnel of the Boston Elevated Railroad. This light signal was arranged to display indications equivalent to those given by the semaphore signal at night, but as there was no moving arm to change the color of the roundel in front of the light, it was necessary to use individual lamps behind the proper colored lens to give the various indications.

From the fact that light signals as originally developed required no moving parts other than the relays controlling the different lamps, it was soon recognized that there was a distinct advantage in their use over the semaphore signal, which, on account of the large number of moving parts, required considerable labor and material to properly maintain them.

While originally used in tunnels and subways, it was soon found that by using lamps of sufficient wattage, proper lenses, reflectors and backgrounds, light signals could also be used in daylight to display the same aspects by day and night.

The first installations for daylight use were made in 1905 on the New York Central Railroad; in 1906 on the Long Island Railroad, and in 1910 at the Pennsylvania Station, New York, N. Y. These were all comparatively short range signals.

The range and spread of light signals vary considerably with the type of lamp used. The more distributed the filament the greater the spread and the shorter the range. The more concentrated the filament the greater the range.

The first installation of long range daylight indication color light signals, using concentrated lamp filaments, accurately located, and factory adjusted was made in 1914 on the New York, New Haven and Hartford Railroad.

Since 1940 very few semaphore signals have been manufactured and most railroads now install light signals for both new work and renewals.

At the present time (1949) the use of light signals has become so general and there are so many types that they will be grouped into three general classes as follows: color light, position light, and color position light.

The aspects and indications for these light signals are fully covered in Chapter II—Symbols, Aspects and Indications.

Color Light Signals

As the name implies, colors only are used to give the different indications and these are similar to the corresponding night indications given by semaphore signals; that is, red for Stop, yellow for Approach, and green for Proceed, with sometimes an additional qualifying light to provide the desired indication.

To meet various requirements there are a number of different types of color light signals manufactured, which may be grouped into two classes: *viz.*, long range and short range.

Long range signals.

Long range signals are generally used where trains operate at high speeds and it is desirable to observe the indication as far from the signal as possible. The aspect of long range signals can be seen from a distance of 2,500 to 5,000 feet in daylight. This long range is obtained by the use of optically efficient lenses and reflectors and by accurate location of the lamp filament at the focal point of the optical system. Maximum efficiency is secured by the use of lamps having accurately located concentrated filaments, by the use of suitable backgrounds and hoods, and by careful alignment of the projected beam. Lenses of $8\frac{3}{8}$ inch diameter are generally used.

Close-up indication for long range signals is provided through the use of deflecting prisms and where signals are located facing a curve an outer roundel is added in front of the existing outer lens to spread or deflect the beam as desired.

Short range signals.

The aspect of short range signals can be seen from a distance of 1,200 to 2,500 feet. They are generally used in tunnels, subways, slow-speed inter-urban traffic and for dwarf signals. Lenses are generally from 5 to $6\frac{3}{8}$ inches in diameter.

Signal units.

Signal units consist of iron cases provided with brackets or a socket, for mounting on ground or bridge masts, with individual lens units arranged vertically, horizontally or triangularly.

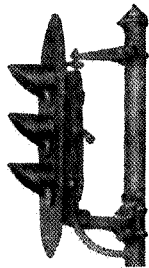

Fig. 1.

Style R-2, Color Light Signal.

Figures 1 and 2 illustrate signal units with lens units arranged vertically and spaced about 12 inches center to center. The usual arrangement is green on top, yellow in the middle, and red on the bottom.

In the type illustrated in Fig. 2 the lens units are contained in separate cases and the cases bolted together, one above the other, to form the signal

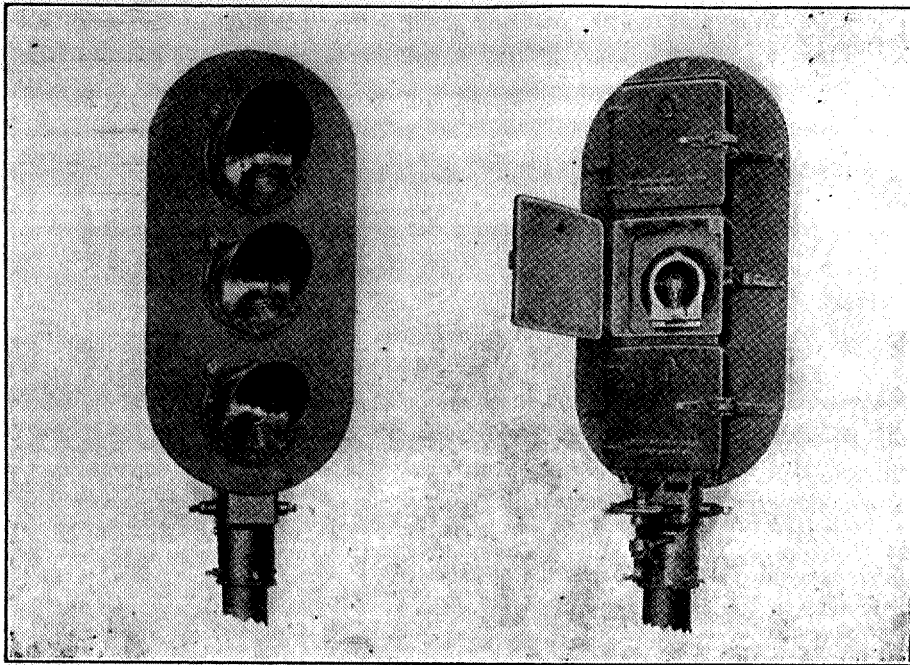

Fig. 2.
Type D, Color Light Signal.

unit. Each lens unit has what is known as a doublet lens, which is a combination of two special lenses, by means of which considerably more beam candlepower is obtained than with a single optical lens. The doublet lens unit is illustrated in Fig. 3.

From this figure it is seen that the corrugations or stepped surfaces of the lenses face each other in a dust-proof compartment with the smooth surfaces exposed. This arrangement makes it very easy to keep these surfaces clean and efficient for light transmission. The outer lens is clear glass while the inner one is colored.

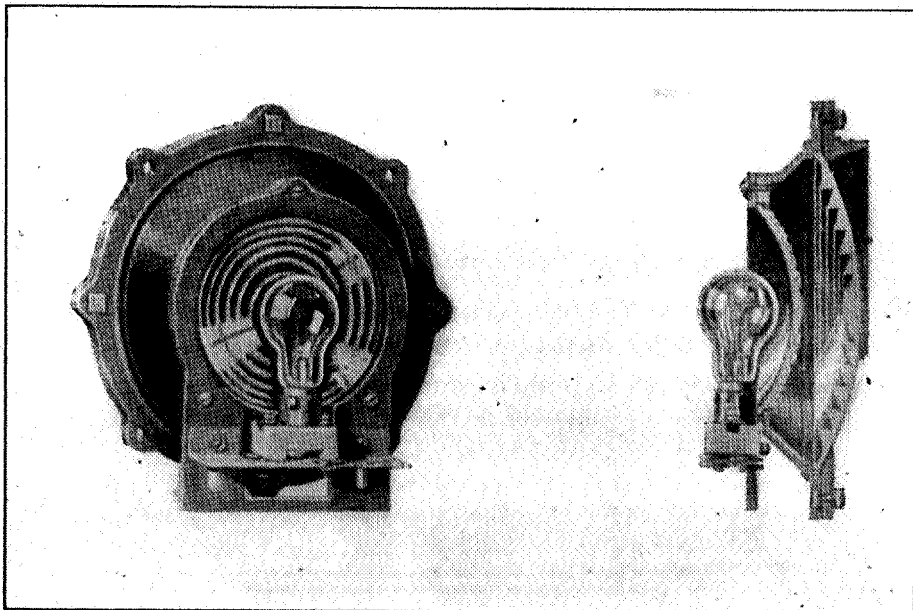

Fig. 3.
Doublet Lens Unit.

These doublet lens units are furnished with receptacles for accurately based signal lamps. The receptacle, or socket, is supported in a fixed relationship to the lens bringing the lamp filament to the exact focal point of the lens system in order that the accurately based lamps may be interchangeable and the range of the signal not altered when the lamp is replaced.

The doublet lens unit used for long range signals has an outer lens $8\frac{3}{8}$ inches in diameter with a 4-inch focal length, and an inner lens $5\frac{1}{2}$ inches in diameter. The focal point of the lens combination is $\frac{1}{2}$ inch back of the inner lens. Due to the short focus of the combination, the lens collects 155 degrees of effective light from the front of the lamp. The bezel rings and frame, which hold the two lenses, are accurately machined so that when the signal unit is assembled the lenses will align and be held in their correct positions. The doublet lens, with lamp and receptacles shown in Fig. 3, may be removed as a unit. Lamps may be replaced without changing the focal adjustment, but due to warpage and slight variation in lenses, some loss in optical efficiency may occur when lenses are replaced.

On signals for daylight use each signal unit is equipped with a background and each lens unit with a hood.

The purpose of the hood is, as far as practicable, to shield the lens unit from the sun-rays and to protect it from snow or sleet. With the hood the unit has the appearance of being set in a dark well. To further this effect, the flat sheet-iron background is used. If signals could always be so located that there could be a natural dark background to bring out the effect of the light, this artificial background would not be required.

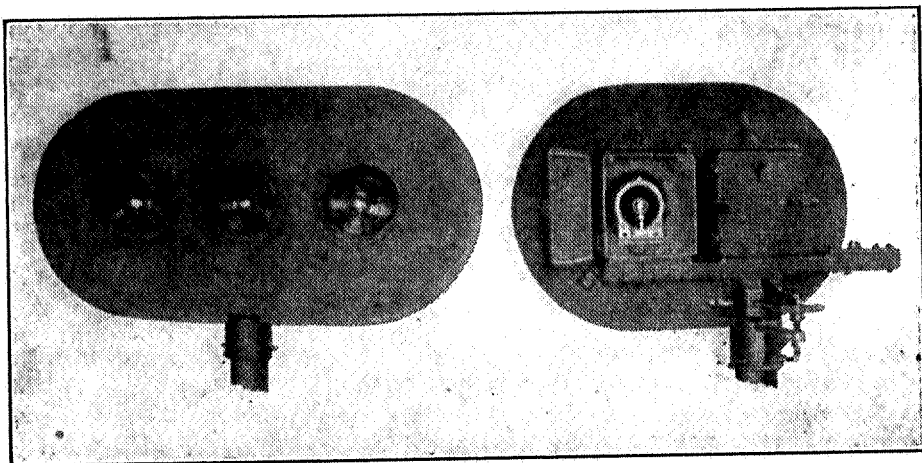

Fig. 4.
Type E, Color Light Signal.

Figure 4 illustrates a horizontal arrangement of lens units, which has the advantage of close vertical spacing between signal units on the same mast. The construction details are practically the same as for the vertical type, except that which may be necessary to arrange the lens units horizontally instead of vertically. As can be readily seen, the vertical type requires greater height of mast where two or more three-indication signal units are used as compared with the horizontal type.

When indications require the use of two or more lights at the same time, the general practice is to space the signal units so that the lights are separated from 4 to 7 feet.

Two-indication as well as three-indication units are in general use. The illustration on right side of Fig. 4 shows a back view of a two-indication horizontal unit. One-indication units are sometimes used to qualify the aspect displayed by two or three-indication units. When so used they are sometimes called "marker lights."

Figures 5 and 6 illustrate the triangular type of color light signal.

This arrangement of lens units makes it comparatively small in size and well suited for use where clearances are limited or where close spacing between units on the same mast is desired. The construction details in these units are practically the same as for the vertical and horizontal types, the assembly being a triangular arrangement of the units spaced about 9 inches center to center.

The color and arrangement of these lens units may be as desired. Generally the red lens is located in the bottom unit.

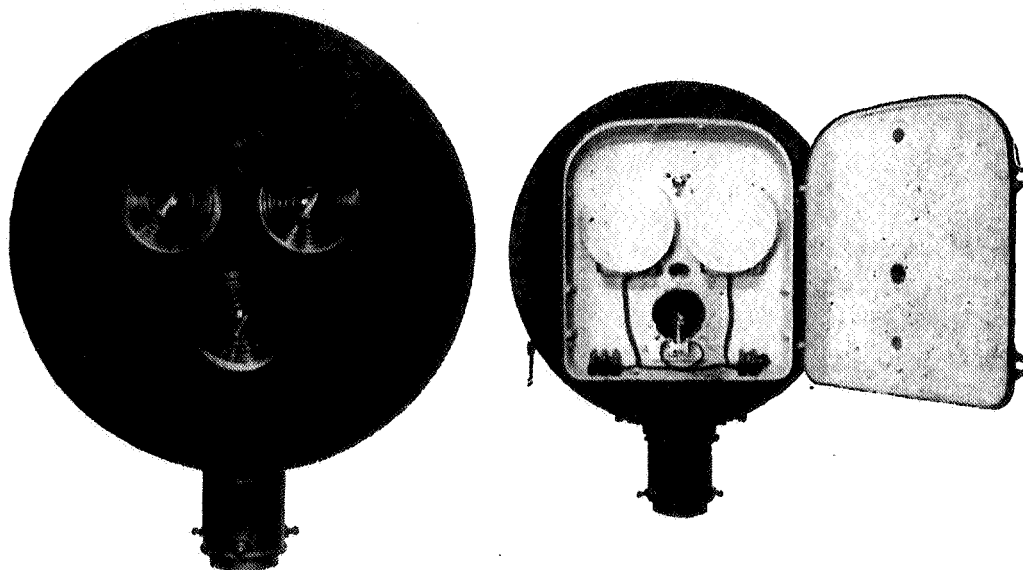

Fig. 5.
Type G, Color Light Signal.

Figure 7 illustrates a signal designed for subway use. It is equipped with 5-inch single colored lenses. When equipped with 6³/₈ inch doublet lens units, it may be used as a short range signal for daylight indication. This signal can be used where clearances are limited, the case for a three-indication unit being cast in one piece. Hoods and backgrounds are not used with subway signals. Low-voltage, low-wattage screw or single contact bayonet candelabra base type lamps are usually used.

Figure 8 illustrates a signal similar to Fig. 2, except it is smaller in size, for use where close clearances prevail. This type signal is used on inter-urban electric railways and as either two or three-indication dwarf signals

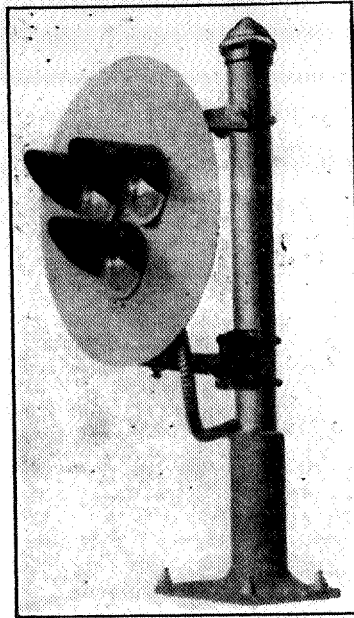

Fig. 6.
Style TR-2, Color Light Signal.

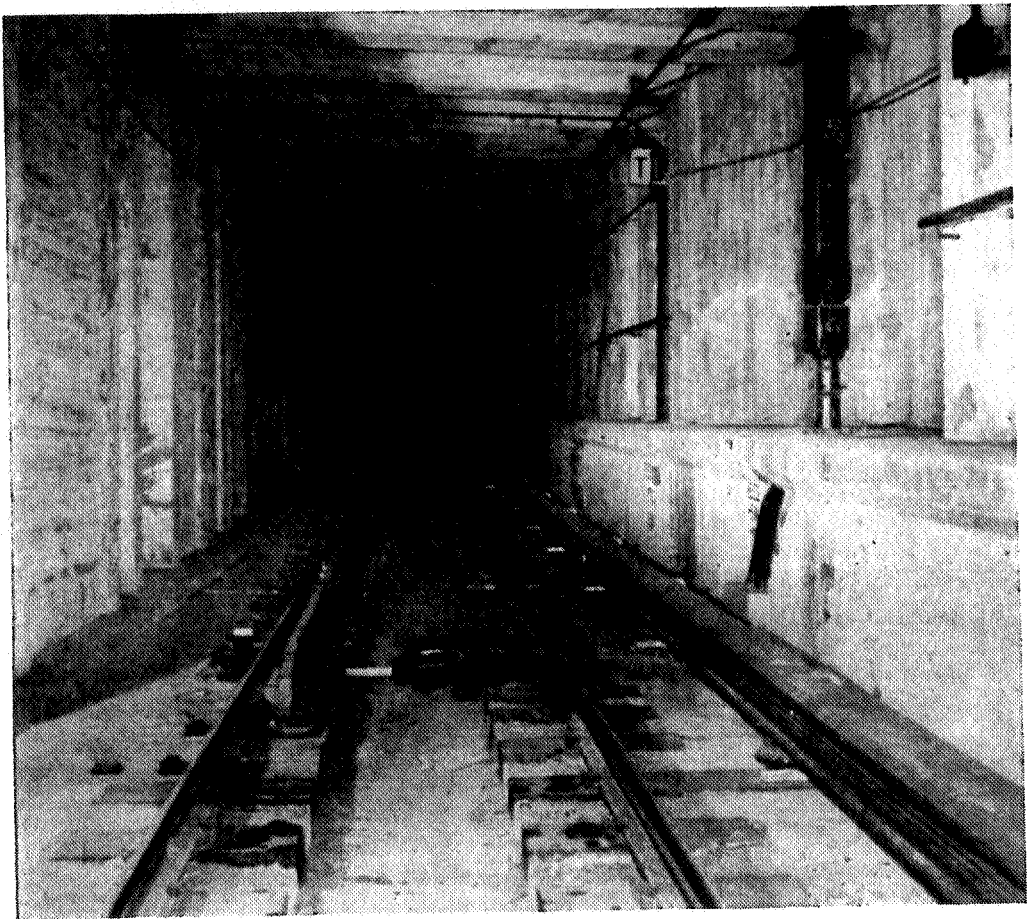

Fig. 7.
Type AT, Color Light Signal.

on steam railways. While this figure shows the signal as a dwarf, the high signal is similar in all respects except that the case is arranged for application to an iron post instead of directly to a foundation. This signal has 5-inch doublet lens units, which, except for size, are similar to the $8\frac{3}{8}$ inch doublet lens units previously described. The outer clear lens is 5 inches in diameter and the inner colored lens is $3\frac{5}{8}$ inches in diameter. The lens unit employs the same type of lamps as used in the $8\frac{3}{8}$ inch doublet lens unit.

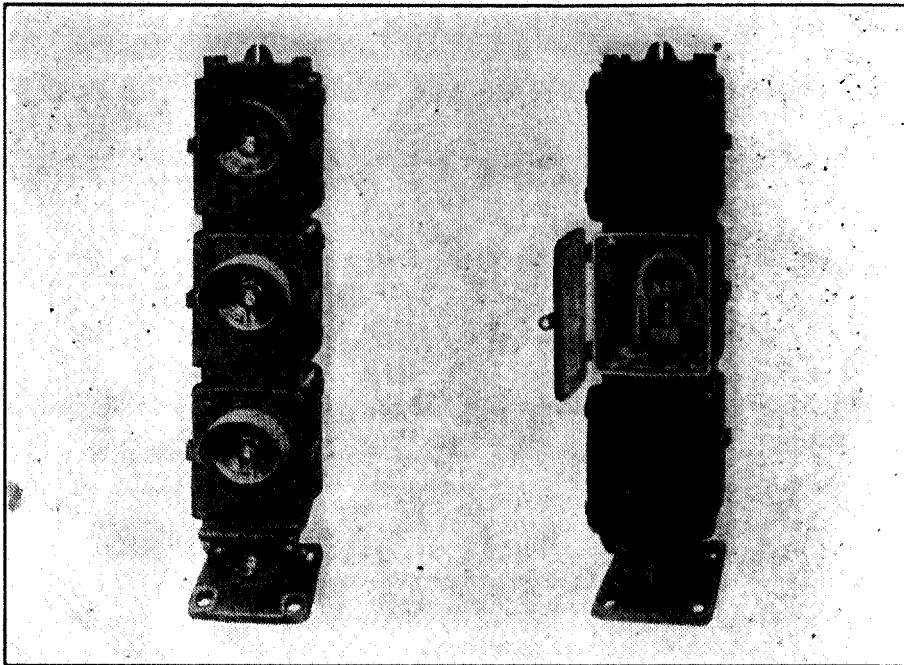

Fig. 8.
Type F, Color Light Signal.

Figures 9 and 10 illustrate two other types of signals. These signals consist of cast-iron cases with either two or three openings, to which have been applied doublet lens units, the outer clear lens being $6\frac{3}{8}$ inches in diameter and the inner colored lens $5\frac{1}{2}$ inches in diameter.

The Style N type is for short range and has lamp receptacles for medium screw base lamps. The lamp receptacles are mounted on an adjustable bracket so that the man in the field can adjust the lamp filament to insure a satisfactory indication whenever lamps are replaced. Commercial medium screw base lamps with semi-concentrated filaments are usually used in this signal.

The Style N-2 signal is similar to the Style N, the difference being in the type of lamp used. This signal is equipped with lamp receptacles which are accurately located and fixed in position at the factory so that the filament of a precision lamp will be located at the focal point of the lens combination, and can be used for longer range than the Style N signal.

A triangular arrangement of these lens units is sometimes used to provide greater vertical clearances for a three-indication signal.



Fig. 9.
Style N or N-2, Color Light Signal.

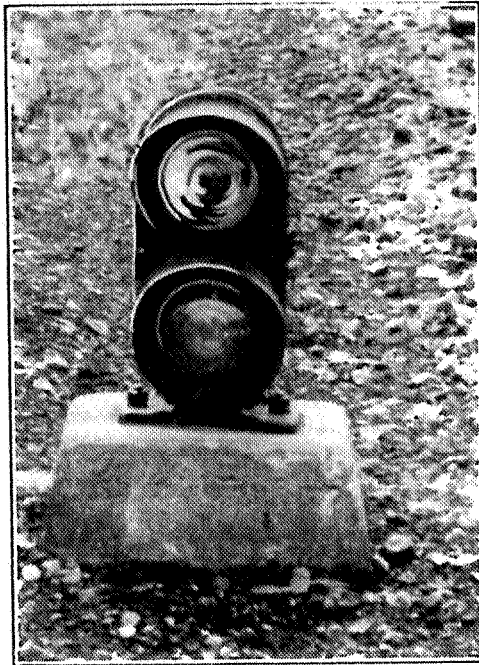

Fig. 10.
Style N or N-2, Color Light Dwarf Signal.

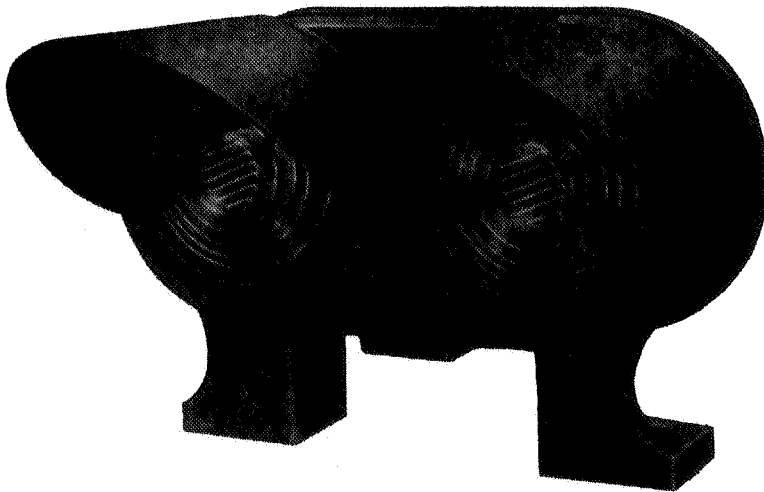

Fig. 11.
Style ES-25, Electric Switch Signal.

Figure 11 illustrates a special horizontal arrangement of $6\frac{3}{8}$ inch doublet lens units as a signal unit for giving medium-range daylight indication of switch point position. Two colors only are used and are projected in one direction only. The lens units and lamps used are the same as described for signals illustrated by Figs. 9 and 10.

Other types of electric switch signals sometimes used are designed for short-range daylight indication. These units also have a horizontal arrangement of two colors and in addition provide for indications forward as well as to the rear. The lens units are made up with $3\frac{1}{2}$ inch diameter lenses for one type and $5\frac{3}{8}$ inch diameter lenses for another type.

Searchlight type.

Figure 12 shows another type of color light signal unit known as the searchlight signal. It differs from the units previously described in that all aspects are projected through one optical system. This is accomplished by means of a movable member of the unit placing a small colored disc or roundel of desired color on the optical center line of the signal directly in front of the lamp so that all rays from the light source are projected through it.

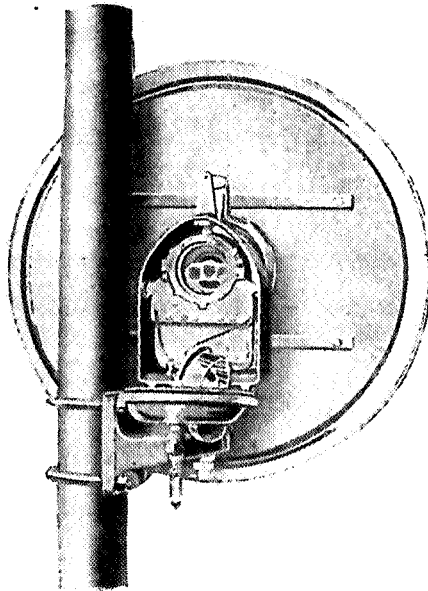

Fig. 12.
Color Light Signal, Searchlight Type.

The movable member of the unit mentioned is a relay mechanism of the three-position type, so arranged that when de-energized it will assume the neutral central position and give its most restrictive indication; the mechanism may be of either the alternating or direct current type.

When operated by alternating current a polyphase vane mechanism is sometimes used. A direct current mechanism in combination with a separate rectifier is also used for operation by alternating current.

Where the direct current mechanism, Fig. 13, is used the motor principle of operation is employed. Originally an armature and field winding were used, the armature winding being controlled over the line and the field

winding energized locally. For many years a permanent magnet has been substituted for the field coils which eliminates the necessity of local energy.

The colored roundels are approximately one inch in diameter, $\frac{1}{16}$ inch thick, and are made of a specially developed heat-resisting glass accurately ground and polished. As an additional precaution against breakage they are spun into a light aluminum frame; purple and green roundels are assembled in two pieces, designated as "pre-cracked."

The signal was originally furnished with $6\frac{3}{8}$, $8\frac{3}{8}$, or $10\frac{1}{2}$ inch diameter stepped lenses having focal lengths of $3\frac{3}{4}$, 5 and 6 inches, respectively. Different lens combinations were employed to meet the varying conditions of railroad requirements, such as spreadlite lens for curves, where it is necessary to have horizontal spread greater than that provided by the half toric optical lens.

Most searchlight signals furnished in recent years have had a ground and polished plano-convex doublet lens combination—the outer lens being $8\frac{3}{8}$ inches with an inner lens of approximately $4\frac{1}{2}$ inches in diameter and having a combined focal length of approximately $2\frac{3}{8}$ inches. This doublet lens combination is much more efficient optically than any of the single molded lenses previously used. This improvement in efficiency is due to the elimination of all molded steps and the use of smooth surfaces characteristic of plano-convex lenses.

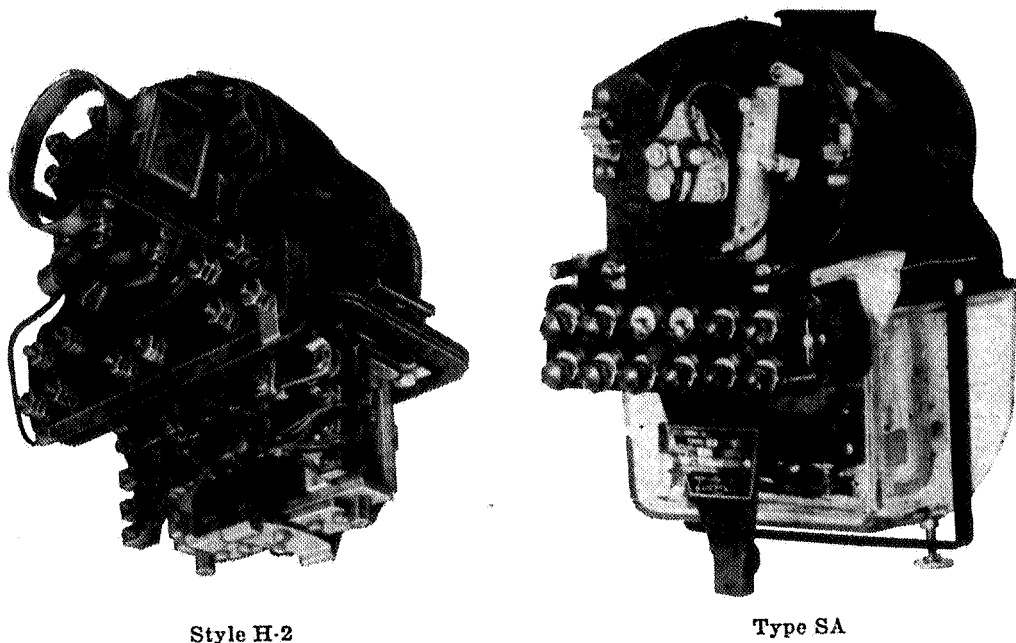

Style H-2

Type SA

Fig. 13.

Direct Current Mechanisms for Searchlight Type Signals.

It can be readily seen that when the mechanism is de-energized the red roundel will be in front of the lamp to give the Stop indication. When the control circuit is energized in one direction the red roundel giving the Stop indication is moved away from and another colored roundel giving a different indication is moved in front of the lamp. When the control circuit is energized in the opposite direction, a different colored roundel is moved in front of the lamp to display still another indication. Generally, the three colored roundels used are red, yellow and green, corresponding with the

standard aspects displayed by the other types of color light signals. Other colored roundels may be used if desired. A reflector is used to collect a large angle of light from the lamp concentrating the rays so that all will pass through the colored roundels and focus at the focal point of the objective lens.

This type of signal is furnished with a receptacle for an accurately based lamp (signal precision) with single-contact candelabra bayonet base.

Figure 12 illustrates the general arrangement of the signal unit attached to a signal mast and used as a high signal.

Fundamentally, the signal comprises a concentrated filament lamp with filament located at the focal point of an elliptical reflector, which collects approximately 80 per cent of the light rays emitted from the lamp, and concentrates them at the second focal point of the ellipse. At this point, which is coincident with the focal center of a clear optical lens combination, the light passes through a miniature colored roundel, enters the lens and emerges in a substantial light beam, as illustrated in Figs. 14 and 15.

Figure 16 shows the unit as a high signal, while Fig. 17 shows it as a dwarf signal.

The high signal is supported by an adjustable bracket which provides a separate horizontal and vertical adjustment. These two adjustments, with the hair line peep sight at the top of the signal, provide an easy means of aligning the light beam. The dwarf signal is mounted on an adjustable base permitting horizontal and vertical adjustment of the unit.

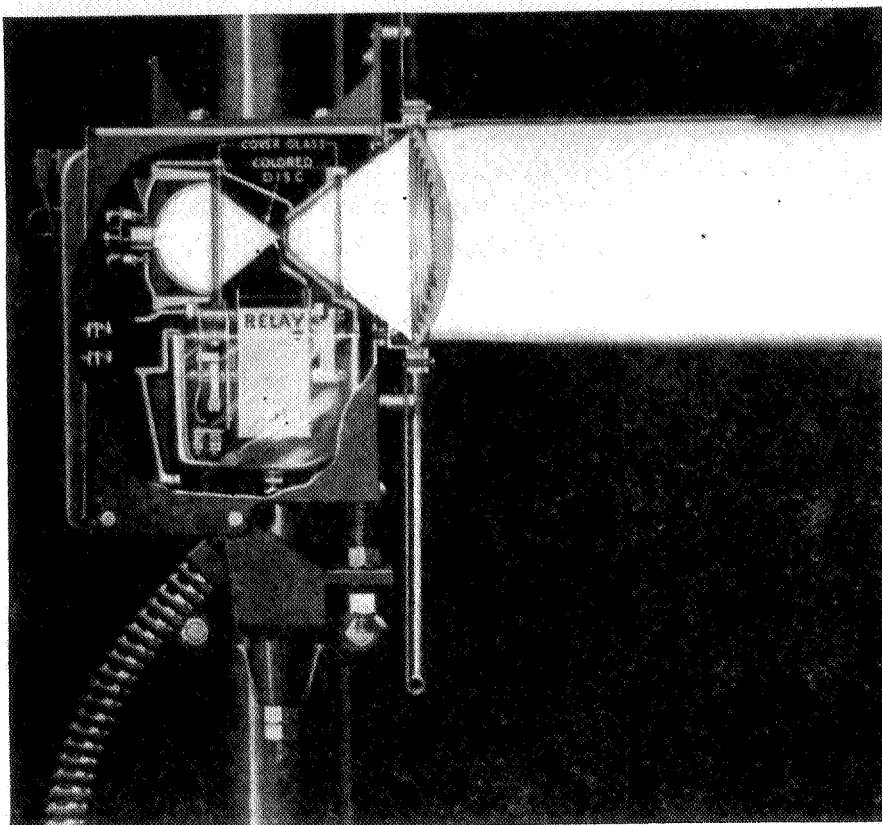

Fig. 14.

Color Light High Signal, Searchlight Type—Stepped Lens.

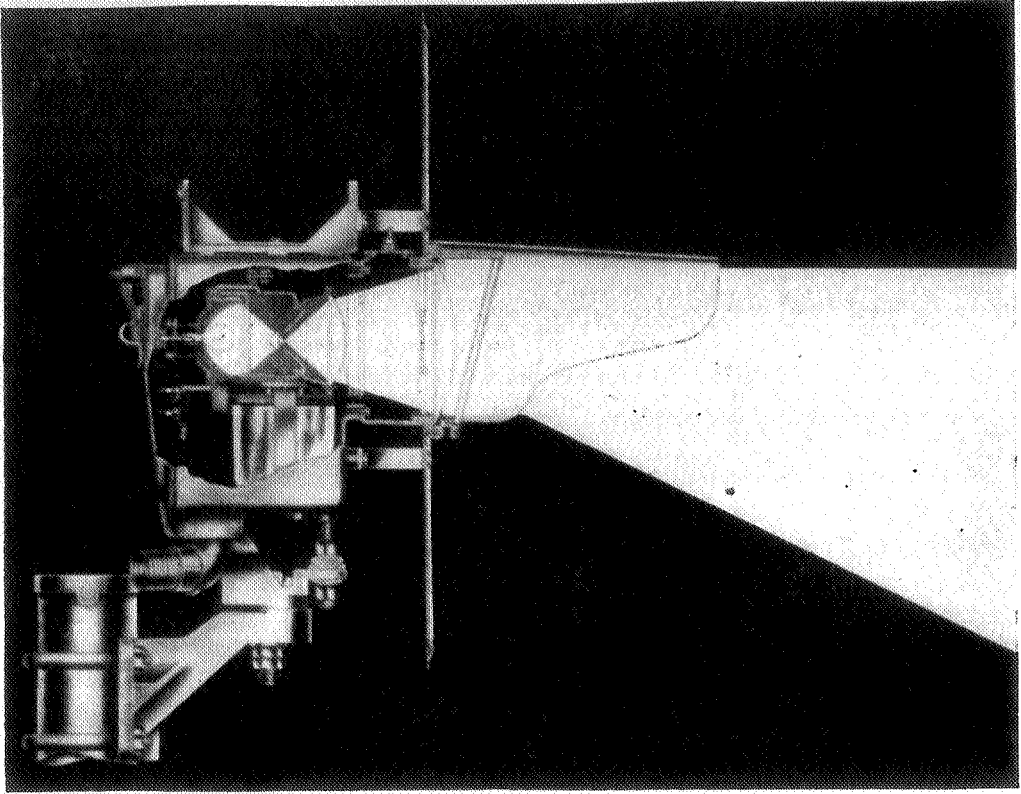

Fig. 15.
**Color Light High Signal, Searchlight Type—Plano-Convex
Compound Lens.**

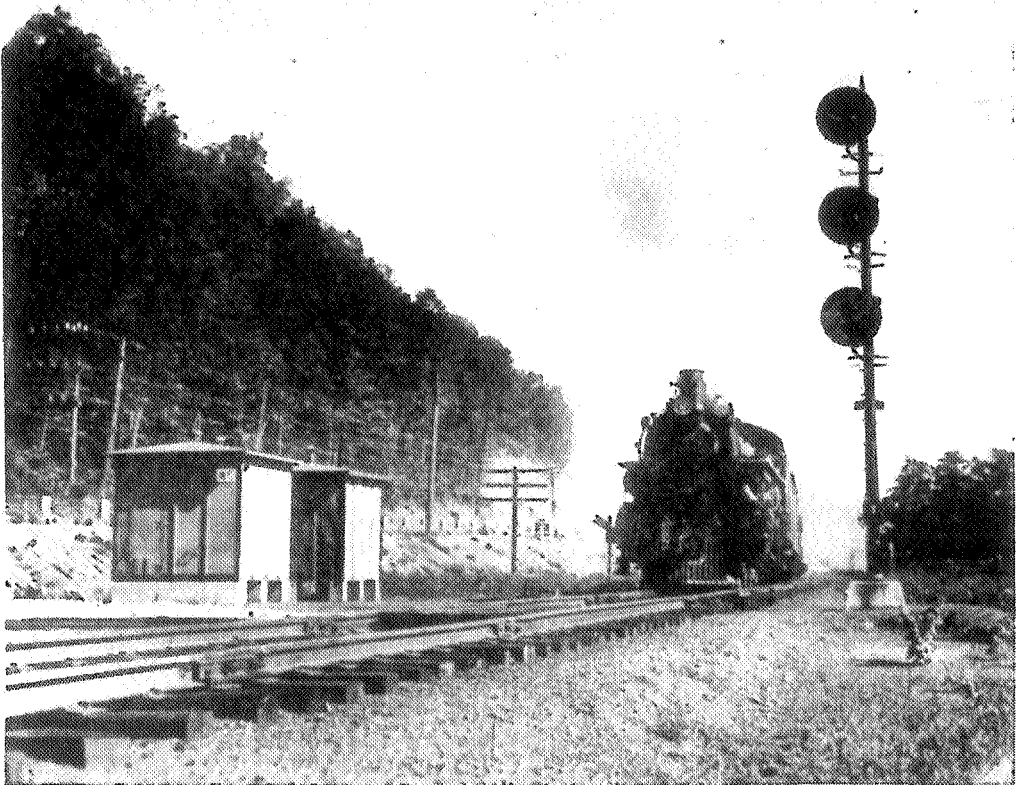

Fig. 16.
Color Light High Signal, Searchlight Type.

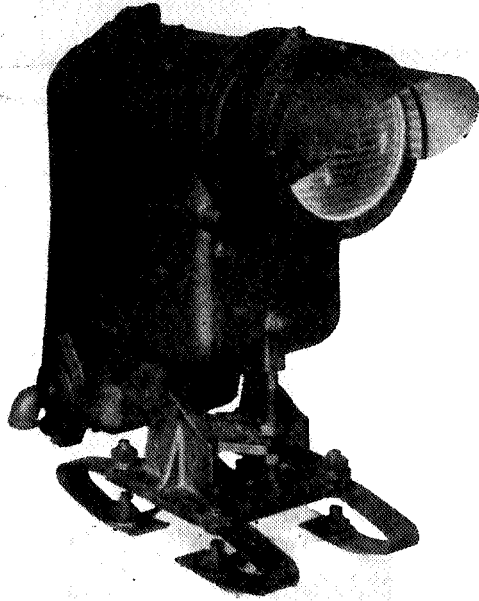
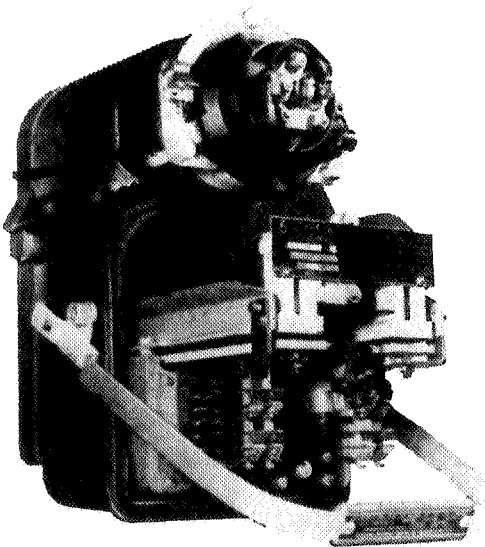

Fig. 17.

Color Light Dwarf Signal, Searchlight Type.

The Type SC mechanism illustrated in Fig. 18 has two direct current tractive type neutral relays mounted side by side in the mechanism case. A linkage connection between the two relay armatures activates a member carrying the colored discs which are arranged in progressive order, usually red, yellow and green. With both relays de-energized the red colored disc is placed before the lamp. With the HG relay picked up the colored discs are moved to place the yellow in position. With the DG relay also picked up the moving member is progressed to place the green in front of the lamp.



With glass removed

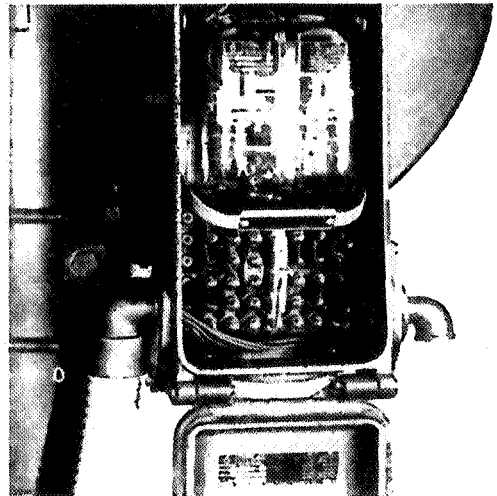

In housing

Fig. 18.

Type SC, Color Light Signal Mechanism.

This type of mechanism is also furnished to operate as a three-position polarized device; the necessary permanent magnet, rectifier, interlocking between armatures and electrical interconnections being self-contained in the mechanism case.

Both neutral and polar types are arranged with a plugboard which automatically connects with a mating plugboard when the mechanism is installed in the signal housing. The plugboard in the signal housing is wired to a terminal board for field connections.

Position Light Signals

For the purpose of eliminating the colored lights for display of the various signal indications and at the same time provide a similar aspect for day and night indications, the position light signal was developed.

The high signal consists of rows of three lamp units corresponding to the positions occupied by the arms of semaphore signals.

High and dwarf position light signals are available. High signals may be mounted upon a ground mast, signal bridge or cantilever post. The dwarf signal is usually mounted upon a foundation or close to the ground by means of a wall bracket or post.

The high signal can be arranged to give indications corresponding to one arm, one arm with marker, two arm, or any other combination desired. Each arm equivalent can give one, two, three or four distinct positions.

As previously stated, the high signal is made up of rows of lamp units, each row consisting of three cast-iron lamp cases mounted on 1¼ inch pipe supports extending radially from an iron central hub equipped with U bolts for applying to a 5-inch pipe mast. The hub casting serves also as a terminal box. The lamp units are located on an 18-inch radius about a central lamp unit. The wires leading to each lamp unit pass down through the 1¼ inch pipe supports into the terminal box. From the terminal box the wires lead into the signal mast through a flexible connection so that the signal unit may be aligned without disturbing the wiring, all parts of the unit being easily accessible.

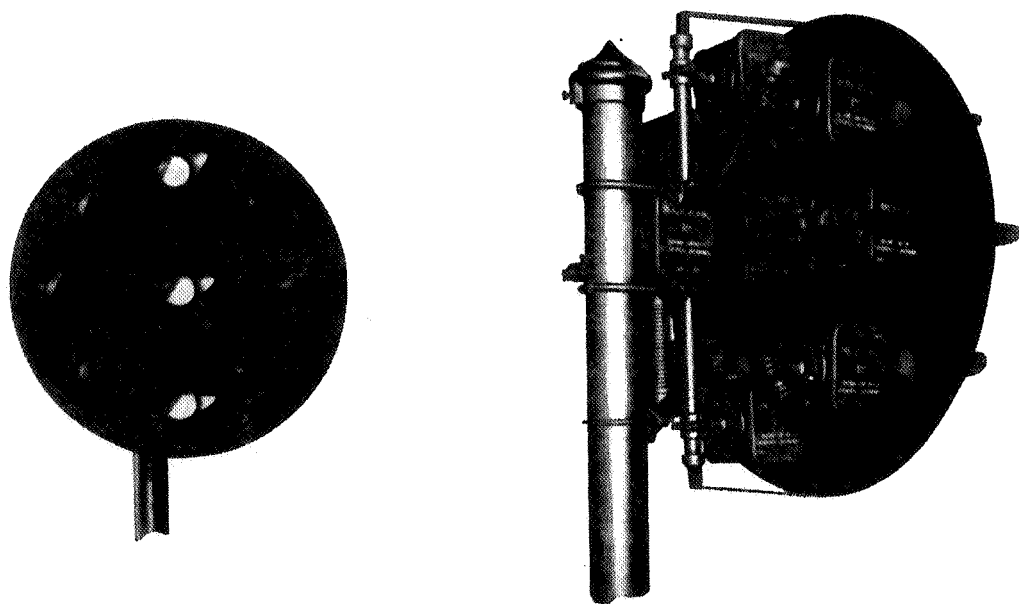

Fig. 19.
Position Light Signal.

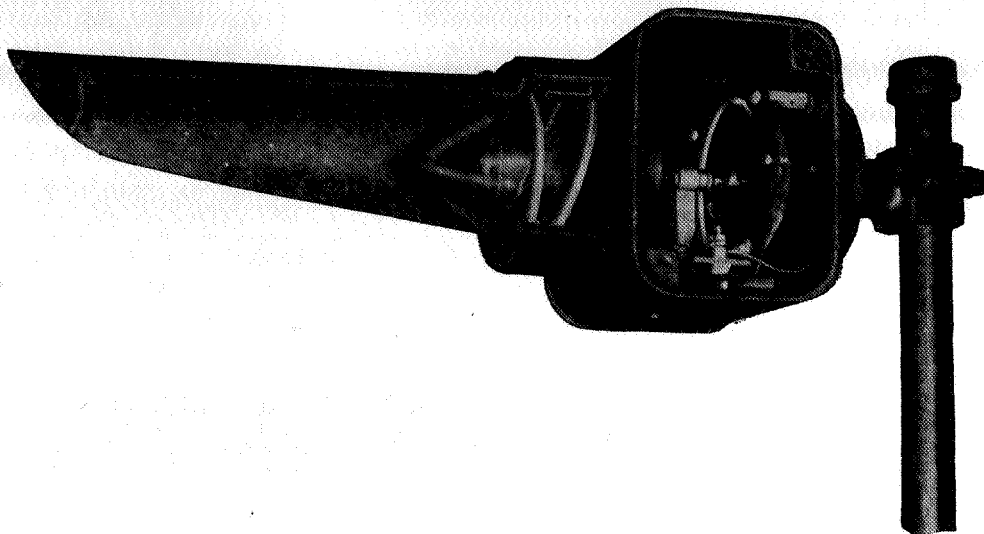

Fig. 20.

Light Unit for Position Light Signal.

A sheet-iron background, attached to the pipe supports by means of substantial brackets, is used for the complete signal unit. These backgrounds are of two shapes: circular and oblong. The circular one is generally used for the top unit, while the oblong one is used where it is only necessary to bring out one row of lights such as the vertical row on the bottom unit.

Figure 19 illustrates a front and rear view of a typical position light signal.

A standard signal platform with extended hand rail and standard ladder provides ready access to the signal unit and terminal box when located on ground masts. The signal unit on bridge signals is so located as to make ladders unnecessary.

The light unit, Fig. 20, consists of a case with a door on each side into which the optical assembly and light source are fitted. The case is also fitted with a hood over the cover glass. The lamp receptacle is for an accurately based light signal lamp which is so located that the filament of the lamp is at the focal point of the reflector and the beam is in alignment with a removable sighting device. Lamps are single-contact bayonet candleabra type and can be replaced without affecting the alignment or intensity of the beam.

The reflector in the optical assembly is glass $5\frac{1}{2}$ inches in diameter and is of a spheritoric type. A spreadlight roundel mounted between the reflector and cover glass and in front of the phankill screen spreads the main beam 18 degrees horizontally. The top portion of this roundel deflects a portion of the beam 30 degrees downward for close-up indication. This glass is inclined 15 degrees from vertical so that any external light reflection from the flat front surface is directed above the beam into the case or hood. The cover glass is conical in shape, of amber or slight yellowish tinted glass with a frosted tip. The conical shape and frosted tip as well as the phankill screen are to prevent reflection from external light.

The phankill screen consists of a series of adjacent equilateral, triangular openings with $\frac{1}{4}$ inch long sides and 1 inch deep from front to back, located between the light source and the cover glasses so as to reduce the reflection of external light from the reflector back of the lamp.

The mounting bracket for the light unit is attached to the case through a ball and socket joint and by four bolts to permit of any adjustment that may be necessary to properly align the unit. The other end of this bracket is attached to the 1¼ inch pipe support.

The hood projects over the cover glass a sufficient distance to prevent the direct sun-rays from striking the cover glass and cutting down the brilliancy of the unit as mentioned under color light signals.

Figure 20 illustrates one of these light units for position light signals with the various parts exposed.

Only one lamp is used in each unit. Should one lamp in any row burn out, there remain two other units lighted which provide a satisfactory indication.

Figure 21 shows a position light dwarf signal which is for short-range indication and consists of a single case with four openings for lenses. A door is provided in the back to provide easy access to wire terminals and lamps. The lenses are located on 8-inch center lines, radially from the pivot unit.

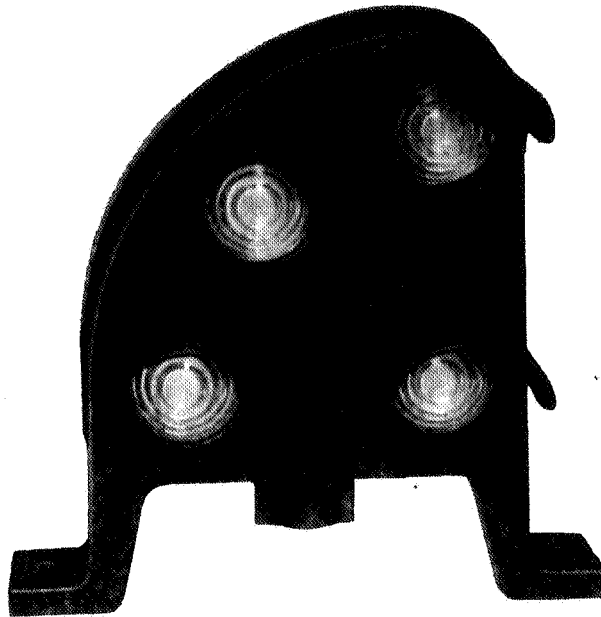

Fig. 21.
Position Light Dwarf Signal.

On account of a short range only being required for dwarf signals and sandblasted or frosted glass being used in the lens assembly, it is not necessary to have the lamp located as accurately with respect to the lens as is done for the light units for high signals. The lamp receptacle is mounted on a bracket attached to the case back of the lens. The lamps used are of the concentrated single filament, single contact-bayonet candelabra base type.

The lens is of clear glass, 4 inches in diameter, behind which is a clear, sandblasted flat 30-degree spreadlight roundel.

Color Position Light Signals

This type of signal is practically a combination of the two previous types in that colors as well as positions are utilized, except that two light units are used in a row. The signal shown in Fig. 22 consists of a main signal unit with marker lens units above and below.

There are various combinations of marker light units located above or below the main signal unit; the center of the vertical ones being located 7 feet above or below the center of the main signal unit. Staggered marker light units are located on a line horizontal to the vertical marker light units and with their vertical center lines 3 feet 4 inches to the left or right thereof. Marker light units staggered to the right display yellow; all others a clear light.

The main signal unit consists of the desired number of light units mounted on supports radially from the center of the background, the units in each row being spaced 2 feet 4 inches center to center.

Each light unit is constructed somewhat along the lines of the doublet lens unit described under color light signals, the outer lens being of clear glass $8\frac{3}{8}$ inches in diameter, the inner lens being of the desired color. The marker light unit is of the same general construction.

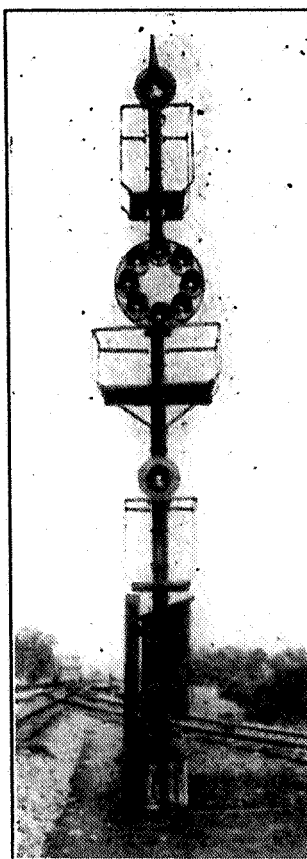

Fig. 22.
Color Position Light Signal.

The light unit case is bolted to the face plate of the signal in such manner as to provide for individual alignment of each unit. The face plate serves as a background. Focus finders are provided so that when lamps are replaced, the receptacles may be readily readjusted to place the lamp filament in focus.

The lamps used have single contact, bayonet candelabra base.

Each row of light units is sometimes supplied with a transformer having suitable taps to provide close adjustment of the lamp voltage. A separate transformer is used for each pair of units displaying red, yellow, green, or lunar white lights.

The color position light dwarf signal shown in Fig. 23 is a compact miniature high signal contained in a metal case with the units in each row spaced $11\frac{1}{2}$ inch centers.

The signal is used with two types of optical systems. In the original type each single clear lens is $3\frac{1}{2}$ inches in diameter and has a flat colored spreadlight roundel mounted directly back of it. In the newer type a doublet lens unit is used consisting of a 4-inch diameter clear outer lens, a $2\frac{3}{4}$ inch diameter colored inner lens, and a clear upward deflecting roundel in front of the outer lens. Focus finders are provided for each doublet lens unit, similar to those in the high signal.

In the dwarf signal it is possible to obtain the same indications as given by the high signals, with the marker units or without marker unit as the case may be. If no top marker units are necessary, the height of the signal is reduced accordingly.



Fig. 23.

Color Position Light Dwarf Signal.

Typical local wiring.

Figures 24, 25, 26, 27 and 28 show typical local wiring for several types of light signals.

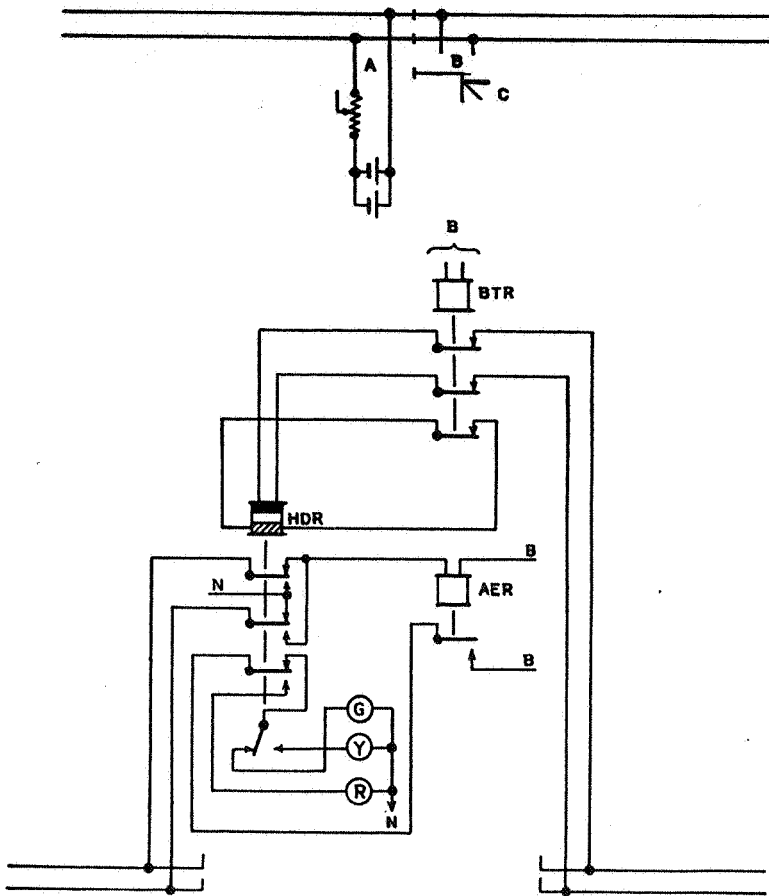

Fig. 24.
 Typical Local Wiring—Color Light Signal.

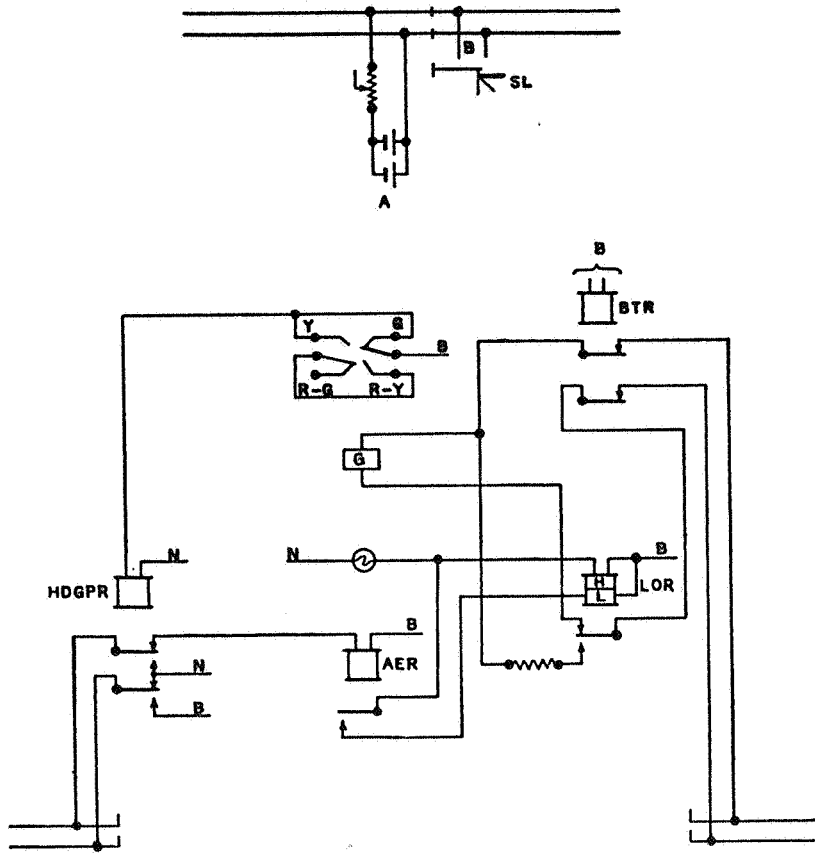

Fig. 25.

Typical Local Wiring—Searchlight Signal.

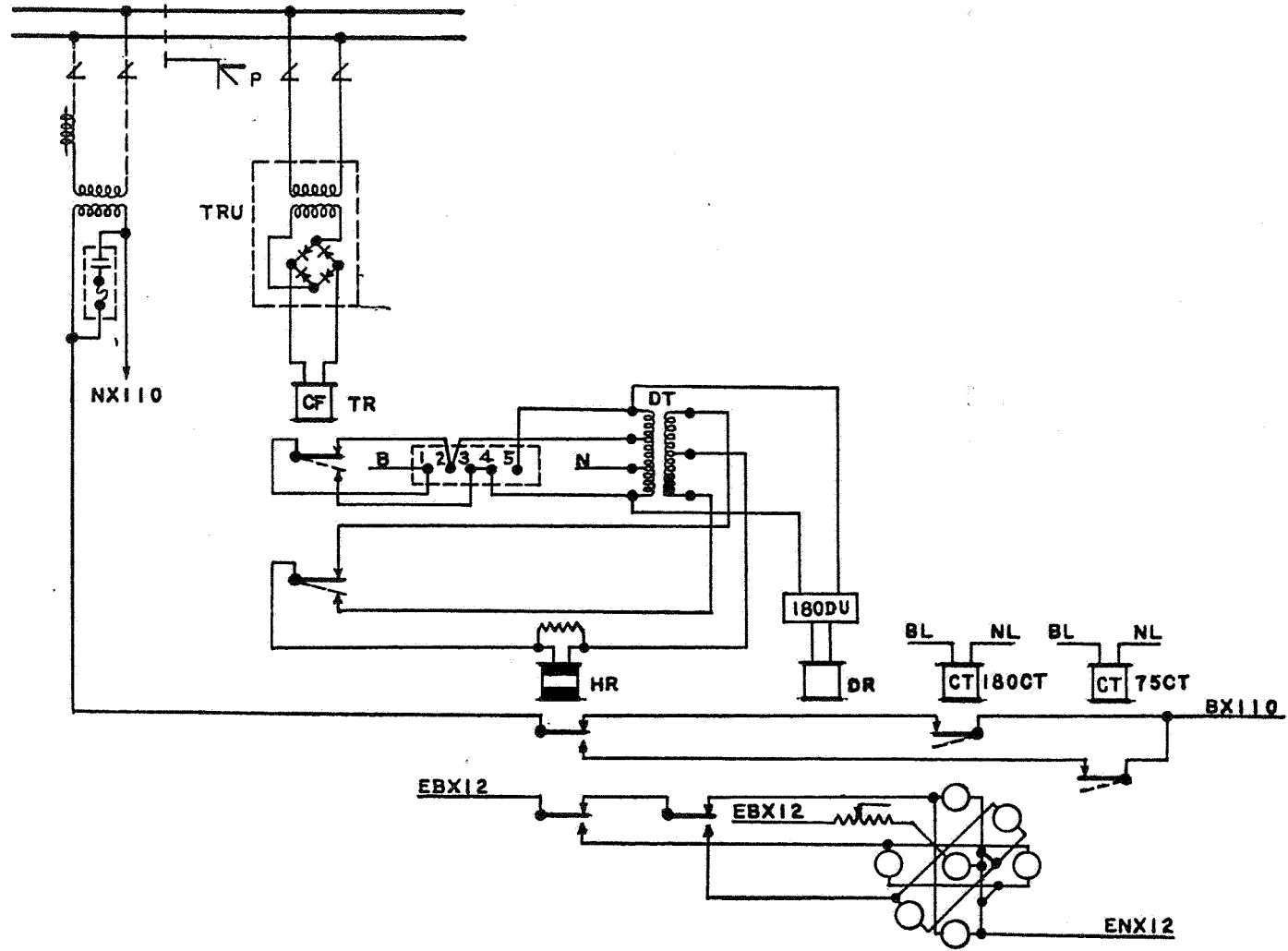

Fig. 26.
Typical Local Wiring—Position Light Signal.

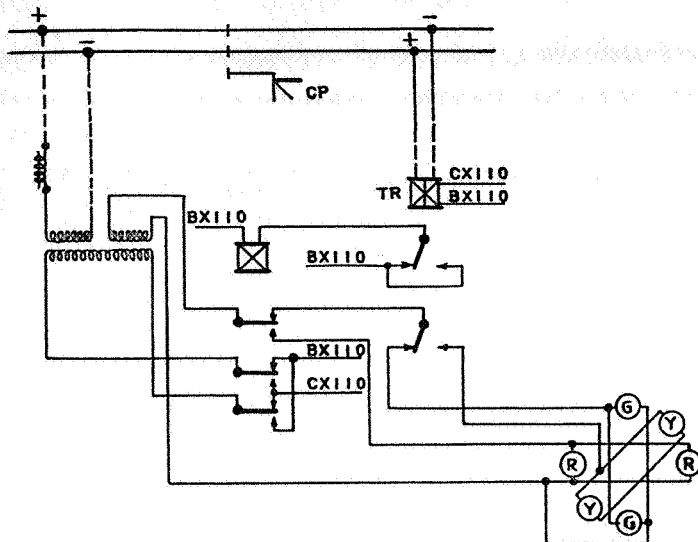

Fig. 27.

Typical Local Wiring—Color Position Light Signal.

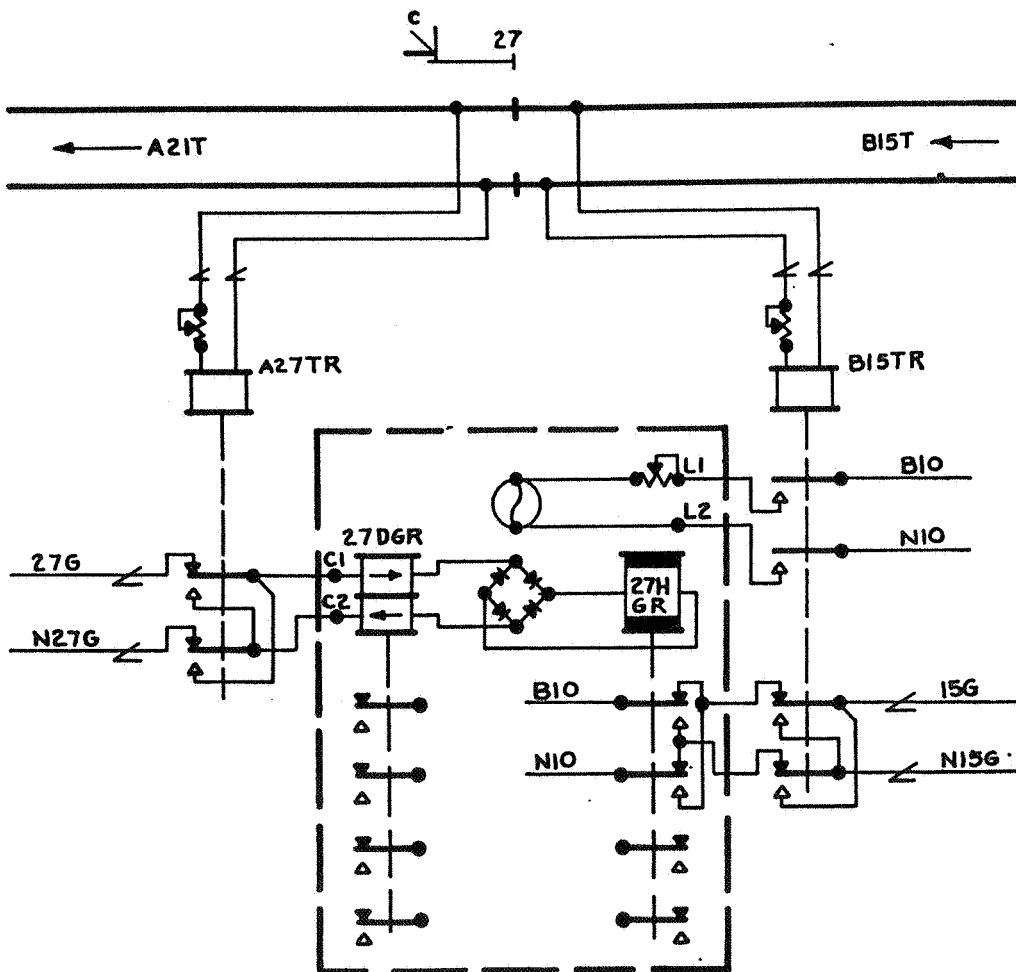

Fig. 28.

Typical Local Wiring—Type SC, Searchlight Signal.

Instructions

Light signals should be maintained and tested in accordance with the following instructions:

General.

1. Mast must be vertical, mounted on suitable support, signal aligned to display the best possible indication for approaching trains and securely fastened.

2. Lens, reflector, roundels, glass and lamps must be cleaned as necessary to insure good indications. Reflectors must be cleaned with a dry soft cloth free from lint and abrasives.

3. Action must be taken when necessary to prevent improper indications, due to reflection of external light.

4. Defective reflectors, lenses, roundels or glass must be replaced.

5. Ladder, hand railing and platform must be kept in good condition and securely fastened.

6. Doors, covers and fastenings must be kept in good condition with suitable gaskets in place so as to keep out moisture and dirt.

7. Housings must be kept clean and must not be used for storing material, tools or supplies unless special provision is made. They should not be opened in severe or stormy weather, except when conditions require.

8. Electric lamps must be maintained and tested as instructed.

9. Bolts, nuts, pins and cotters of proper size and type must be kept in place, nuts kept tight, and cotters properly spread.

10. When movable parts are worn to such an extent as to create excessive lost motion, they must be replaced.

11. Maintenance and repair work which may interfere with safe movement of trains must not be started until train movements have been fully protected. Temporary repairs or adjustments when required must be made in such manner that safety of operation will not be impaired.

12. Tags must be made of insulating material and wire and tags must be so arranged as not to interfere with moving parts of apparatus.

13. Circuits other than track circuits should be kept free of grounds.

14. Tests must be made and recorded as instructed.

15. When making tests of apparatus proper instruments must be used, and it must be known that no unsafe conditions are set up by the application of testing equipment.

16. Manufacturer's instructions must be followed unless they conflict with general or detailed instructions in which case proper authority must be consulted for correct procedure.

Color light signal—searchlight type.

17. Operating mechanism, when placed in service, must meet shop requirements specified in Table of Operating Characteristics for the particular type of signal.

18. Working voltage must be maintained as closely as practicable to rated voltage. Where separate armature and field windings are used low current in one element must not be compensated for by increasing the boosting current in the other element above its rated limit.

19. Relay and reflector units must be securely fastened in place.

20. Changes in the internal parts of the signal, including the lens and lamp receptacles, must not be made from their original settings.

21. Where deflecting prisms are used, care must be exercised to see that they are assembled and maintained to spread the light in the proper direction.

Color light (other than searchlight types), position light and color position light signals.

22. Changes in the internal parts of the signal, including the lens and lamp receptacles, must not be made from their original settings, except that lamp may be changed or reset where provision has been made for proper focusing.

23. Door or cover of light unit of color light signal must be kept closed when train is approaching.

24. Where deflecting prisms are used, care must be exercised to see that they are assembled and maintained to spread the light in the proper direction.

TABLE OF OPERATING CHARACTERISTICS OF COLOR LIGHT SIGNALS SEARCHLIGHT TYPE

Shop Requirements										Field Requirements							
Voltage range contact	Nominal resistance		Initial charge		Minimum drop-away		Maximum pick-up and working		Field energy		Minimum drop-away		Maximum pick-up and working		Field energy		
	Arm.	Field															
Volts	Ohms	Ohms	Volts	Amp.	Volts	Amp.	Volts	Amp.	Volts	Amp.	Volts	Amp.	Volts	Amp.	Volts	Amp.	
3 INDICATIONS WITH FIELD COILS—WITH CONTACTS																	
First	250	500	9.0	0.036	1.5	0.006	5.0	0.020	6.0	0.012	1.0	0.004	6.0	0.024	6.0	0.012	Hall
First	250	500	9.0	0.036	2.5	0.010	6.5	0.026	6.0	0.012	2.0	0.008	7.5	0.030	6.0	0.012	U. S. & S. Co. Inter., H or H2
First	250	300	9.0	0.036	1.25	0.005	5.5	0.022	7.5	0.025	1.0	0.004	6.6	0.026	7.5	0.025	G. R. S. Co. S
First	250	300	9.0	0.036	2.12	0.0085	6.0	0.024	7.5	0.025	1.7	0.0068	7.2	0.029	7.5	0.025	G. R. S. Co. SA
First	430	650	13.3	0.031	3.14	0.0073	8.13	0.0189	12.0	0.0185	2.51	0.0058	9.76	0.0227	12.0	0.0185	G. R. S. Co. SA
First	380	517	11.8	0.031	2.81	0.0074	7.3	0.0192	10.0	0.0194	2.25	0.0059	8.8	0.023	10.0	0.0194	G. R. S. Co. SA
3 INDICATIONS WITH FIELD COILS—WITHOUT CONTACTS																	
First	250	500	9.0	0.036	3.0	0.012	6.5	0.026	6.0	0.012	2.5	0.010	7.5	0.030	6.0	0.012	U. S. & S. Co. Inter., H or H2
3 INDICATIONS WITH PERMANENT MAGNET—WITHOUT CONTACTS																	
First	250		9.0	0.036	2.6	0.0104	5.5	0.022			2.1	0.0084	6.5	0.026			U. S. & S. Co. Inter., H, H2 or H5
First	500		9.0	0.018	3.8	0.0076	8.0	0.016			3.0	0.006	9.0	0.018			U. S. & S. Co. Inter., H, H2 or H5
3 INDICATIONS WITH PERMANENT MAGNET—WITH CONTACTS																	
First	250		9.0	0.036	2.0	0.008	5.5	0.022			1.6	0.0064	6.5	0.026			U. S. & S. Co. Inter., H, H2 or H5
First	500		9.0	0.018	3.0	0.006	8.0	0.016			2.4	0.0048	9.0	0.018			U. S. & S. Co., Inter., H, H2 or H5
First	250		9.0	0.036	1.25	0.005	5.5	0.022			1.0	0.004	6.6	0.026			G. R. S. Co. S
First	250		9.0	0.036	2.12	0.0085	6.0	0.024			1.7	0.0068	7.2	0.029			G. R. S. Co. SA
First	430		13.3	0.031	3.14	0.0073	8.13	0.0189			2.51	0.0058	9.76	0.0227			G. R. S. Co. SA
First	105		5.67	0.054	1.35	0.0128	3.45	0.0328			1.08	0.0102	4.14	0.0394			G. R. S. Co. SA
First	380		11.8	0.031	2.81	0.0074	7.3	0.0192			2.25	0.0059	8.8	0.023			G. R. S. Co. SA
2 INDICATIONS—FIELD AND ARMATURE COILS IN PARALLEL—WITH CONTACTS																	
First	250 (167)	500	9.0	0.054	2.5	0.015	6.0	0.036			1.84	0.011	6.8	0.041			Hall
First	250 (167)	500	9.0	0.054	3.34	0.020	6.5	0.039			2.67	0.016	7.2	0.043			U. S. & S. Co. Inter., H or H2
First	250 (136)	300	9.0	0.066	2.04	0.015	7.2	0.053			1.63	0.012	8.6	0.064			G. R. S. Co. S
First	250 (136)	300	9.0	0.066	2.72	0.020	7.2	0.053			2.18	0.016	8.6	0.064			G. R. S. Co. SA
First	430 (259)	650	13.3	0.051	4.15	0.016	11.1	0.043			3.32	0.013	13.3	0.052			G. R. S. Co. SA
First	380 (219)	517	11.8	0.054	3.50	0.016	9.65	0.044			2.80	0.013	11.6	0.053			G. R. S. Co. SA

Note.—The resistance of the coils may vary 10 per cent, therefore the current or voltage may vary accordingly.

TABLE OF OPERATING CHARACTERISTICS OF COLOR LIGHT SIGNALS SEARCHLIGHT TYPE—Continued

Shop Requirements

TYPE SC

	Nominal resistance	Initial charge		Minimum drop-away		Maximum pick-up and working	
		Volts	Amp.	Volts	Amp.	Volts	Amp.
3 INDICATION POLAR-NEUTRAL							
	275	18.0	0.072	2.75	0.008	6.8	0.026
	425	23.0	0.060	3.4	0.0065	9.0	0.0215
3 INDICATION NEUTRAL-NEUTRAL							
DG relay	700	21.0	0.030	2.66	0.0038	7.7	0.011
HG relay	610	20.7	0.034	2.32	0.0038	8.05	0.0132

Light Signal Lamps

Precision lamps.

A light signal is judged largely by the indication displayed. The quality of the indication and the alignment of the light beam are vitally affected by the location of the lamp filament with respect to the focal point of the lens system. Lamps carefully selected for accuracy of filament location, from large quantity production of commercial lamps, give satisfactory results. Selected lamps, however, are not available to meet the various signaling requirements as to voltage, wattage and filament shapes. Precision type lamps, Fig. 29, accurately based to locate the filament within $\frac{1}{64}$ inch of its true location in axial alignment and light center length, are necessary to assure satisfactory results. The use of $\frac{1}{64}$ inch precision type lamps enables replacements being made without the need of readjustment of lamp receptacles.

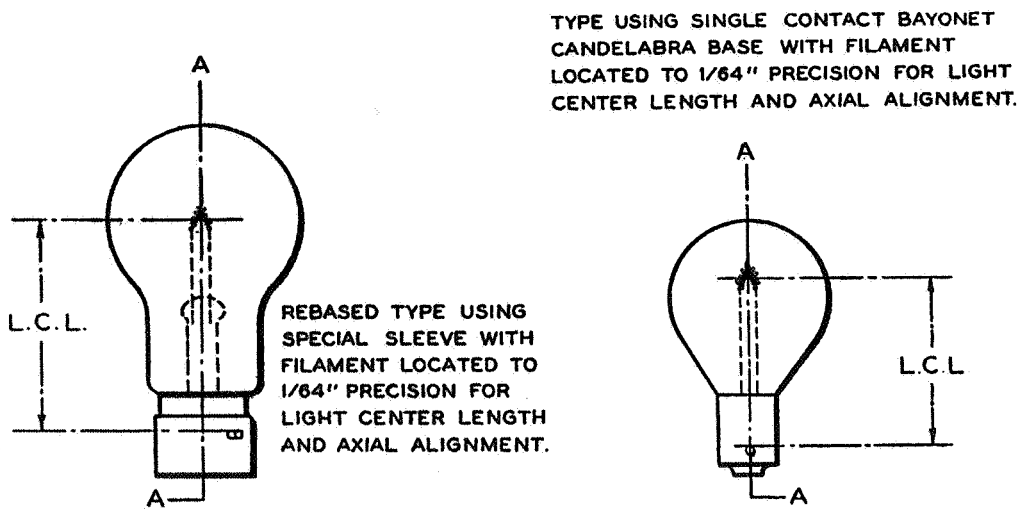

Fig. 29.

"Precision" Type Signal Lamps.

Marked "Signal Precision" Either on Base or on Bulb.

Double filament lamps.

Lamps having two filaments connected in multiple and having equal rating with respect to voltage, wattage and average life, have been in general use for many years. The theory regarding such lamps has been that normally one filament will outlast the other and that in the course of regular signal inspection the burnout of one filament will be noted and the lamp replaced before the other filament fails, thus avoiding the occurrence of a dark signal. Practically, it has been found that in most cases both filaments will fail at about the same time because they are of the same rated life and deteriorate at the same rate. When one filament fails the other is likely to fail immediately or soon thereafter, due to the increase in voltage across the filament that usually occurs on account of a decrease in the voltage drop in the leads and connections.

A later design of double filament lamp combines some of the advantages of both single and older type double filament lamps and at the same time

eliminate some of their disadvantages. The main filament of this lamp wherein the majority of the total wattage of the lamp is concentrated, is accurately located within the focal area of the lens system. The secondary filament is of lower wattage and has a very much longer average rated life.

In a light signal, maximum efficiency is obtained when the light source is most concentrated and located within the focal area of the optical system. The new type double filament lamps having the majority of the total wattage concentrated in the focal area of the optical system, produce the same normal indication as do the corresponding single filament lamps with only a slight increase in wattage.

When the main filament fails, the signal indication is altered by a reduction in beam intensity so that the main filament failure is readily noticeable but the beam intensity is still of sufficient strength to provide a short range indication for train operation at reduced speed.

It is apparent that the use of a main filament with a secondary filament of much longer average rated life greatly increases the probability that the secondary filament will outlast the main filament, thus providing time for discovery of the burned out filament and replacement of the lamp before the failure of the secondary filament. While the occasional failure of secondary filaments before the failure of the main filaments must be expected, the light-out protection afforded by the use of these lamps makes their use desirable since they will give much better average performance than will the older type double filament lamps.

Double filament lamps with the new filament construction are available in the A-15 bulb rebased type, illustrated in Fig. 30 for use in color light signals; S-11 bulb single-contact bayonet candelabra base type, illustrated in Fig. 31, for use in searchlight, color light, position light and color position light signals.

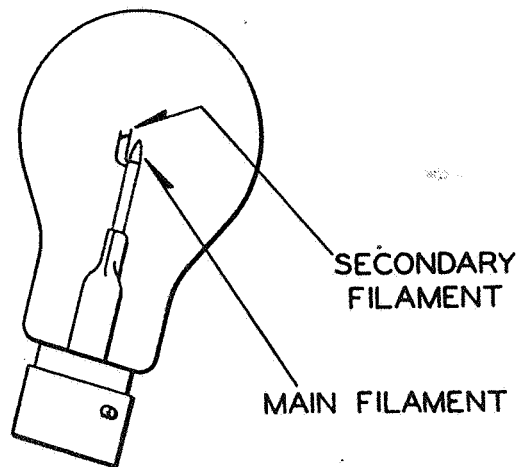

Fig. 30.
Double Filament Lamp.
A-15 Bulb.

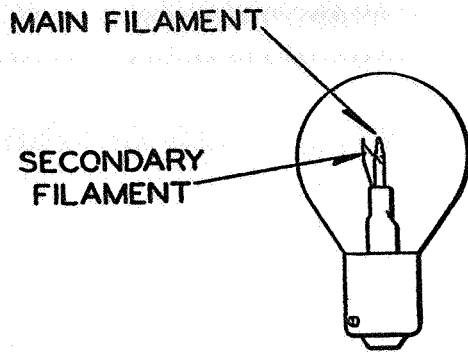

Fig. 31.
Double Filament Lamp.
S-11 Bulb.

Position of filaments.

When double filament lamps are placed in lamp sockets, compliance with the following instructions is necessary:

(a) The A-15 bulb, Fig. 30, rebased lamps with double filament construction should be positioned in the signal lamp socket so that the secondary filament is in back of the main filament with respect to the lens, as illustrated in Fig. 32.

(b) The S-11 bulb, Fig. 31, lamps with double filament construction should be positioned in searchlight signal sockets so that the secondary filament is below the main filament, as illustrated in Fig. 33.

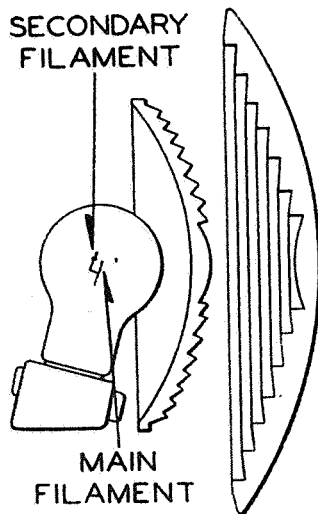

Fig. 32.
Diagram Showing Positioning of Filaments in a Lensing Unit
Having No Reflector.

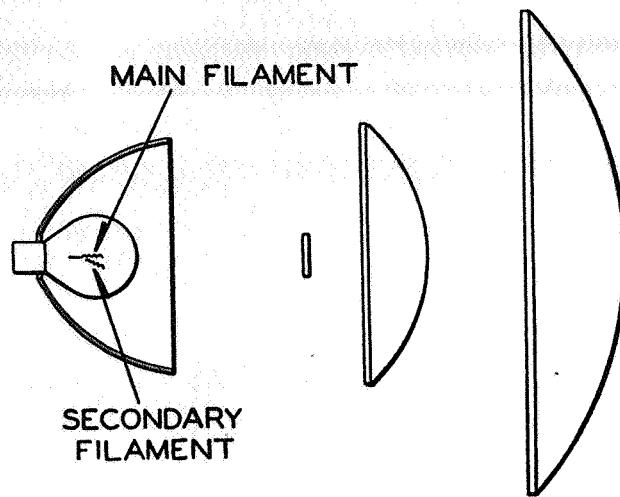

Fig. 33.
Diagram Showing Positioning of Filaments in a Searchlight Signal Unit.

*Lamp Replacements Analyzed**

Best results can be obtained from each type of signal only when the proper type lamp is used and when such lamps are operated and maintained in conformance with their peculiar characteristics.

A modern electric lamp consists of a helix of tungsten wire mounted within a sealed glass envelope. This tungsten wire, or filament as it is called, is so designed that it is raised to incandescence by the flow of electric current through it when voltage is impressed across its terminals. The envelope is either evacuated or filled with an atmosphere of a gas which will not combine chemically with the tungsten filament even at the extremely high temperature of incandescence.

Depreciation in service.

Although rapid chemical decomposition of the filament is eliminated, the wire wears away gradually as the lamp "burns." This process is called "evaporation," atoms of incandescent tungsten metal being thrown off as vapor which condenses and forms a black deposit on the bulb. The life cycle of a lamp is limited by the time required for this evaporation to reduce the wire at some point so that its effective cross-section is insufficient to carry the current which flows. The wire then fuses at this point and the lamp "burns out."

During this life cycle, the lumen output or candlepower of the lamp diminishes, partly on account of attenuation of the metal conductor which reduces the wattage consumed, and partly as a result of the black deposit of tungsten which has evaporated. In common types of lamps used in railroad signal service, the lumen output will have been reduced approximately 15 per cent just before the lamp fails.

* Based on article by Mr. E. W. Beggs, December 1928 issue of *Railway Signaling*.

The light output of any tungsten filament depends entirely upon the temperature at which it operates, which in turn depends upon the voltage impressed. This relationship is illustrated in curve A of Fig. 34. The efficiency of the lamp as a light generating device also varies with the filament temperature and voltage. This is shown graphically by curve B of Fig. 34. This curve illustrates the effect of voltage on lumens per watt (a unit candlepower light source emits 12.57 lumens).

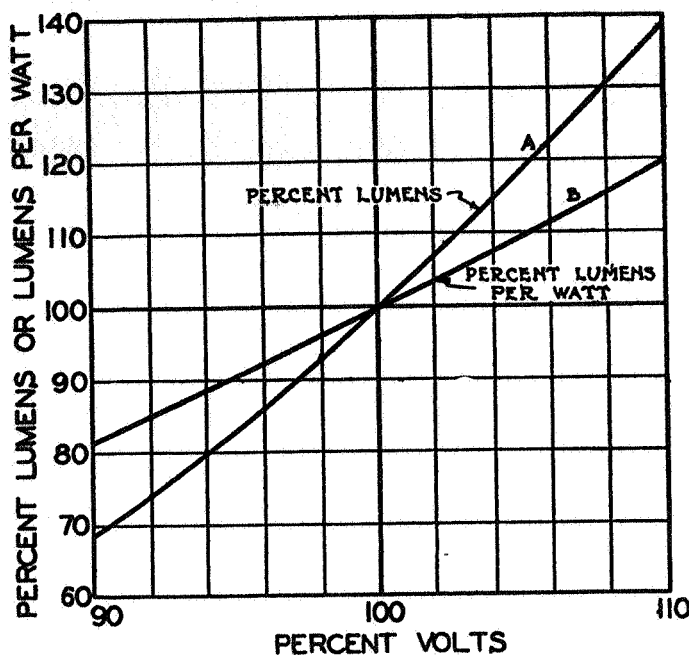

Fig. 34.

Relationship Between Light Output, Lamp Efficiency and Impressed Voltage.

Light output and efficiency increase and decrease in proportion to the voltage impressed on the lamp, but the life of a lamp is decreasing as the light output and efficiency increase, that is, it varies inversely with the voltage. This characteristic of a lamp is illustrated by the curve in Fig. 35. It results from the fact that the rate of evaporation is determined by the operating temperature of the tungsten wire. With higher operating temperatures, this rate is greatly increased.

Naturally, very minute variations in effective cross-section of a tungsten filament cause large variations in local temperature. A relatively small rise in temperature causes a great increase in the evaporation rate. For this reason, it is necessary to reduce variations to the absolute minimum. Tungsten filaments of well-made lamps vary so little that it is practically impossible to detect irregularities by measuring devices now available. These variations in small filaments of ordinary commercial lamps are kept within one-millionth of an inch. Uniformity of the tungsten conductor is no more important than purity of the atmosphere in which it operates. There are no devices available today which are capable of detecting the minute quantity of impurities present in an ordinary commercial lamp.

The third most important factor which affects lamp performance is the accuracy with which the filament is formed and mounted within the sealed glass container. The variations which exist in the filaments of individual lamps are measurable but these two are kept to a minimum. They are being constantly reduced by the introduction of new machinery being developed to replace the hand labor which has always been considered necessary in lamp making.

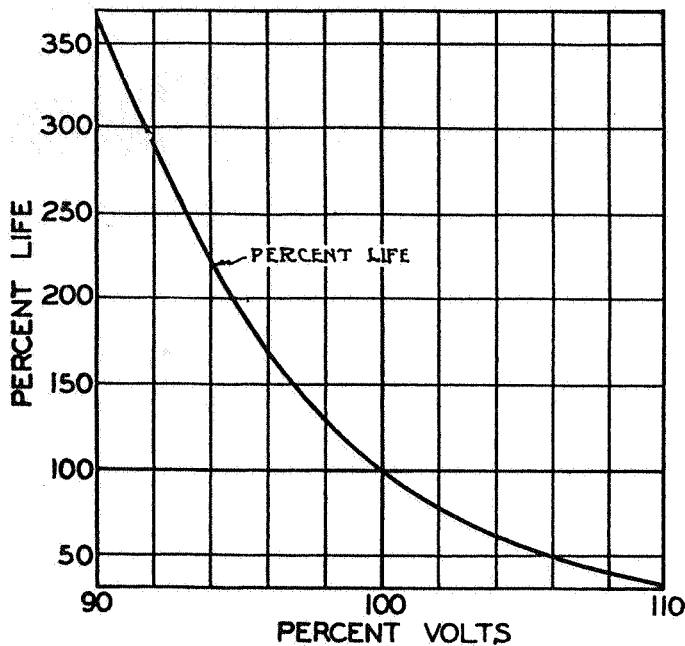

Fig. 35.

Variation in Lamp Life with Impressed Voltage.

On account of these three principal factors and other minor ones, the life and performance of any individual lamp cannot be exactly predicted even under absolutely controlled operation conditions. Only the average life of a group of lamps is within the control of the lamp manufacturer. That life is called the "design life" of the particular type of lamp in question. If all the factors which have a bearing on lamp performance could be absolutely controlled, each lamp in the group would burn exactly the "design life." Although perfect control is still not in sight, nevertheless the deviation of any individual lamp from the average is relatively small.

Mortality curve.

The results of years of testing have shown that whereas the life of any one lamp is always unknown just as it is with human beings, nevertheless a life expectancy table may be used with confidence just as it is used by life insurance companies in calculating premiums. The lamp mortality curve is shown in Fig. 36. This curve represents tests of large quantities of railway signal lamps. It shows that at various points throughout the life of the group, certain definite percentages of the lamps tested will have failed, while the remainder will be still giving service. For instance, if the average life of the group is 1,000 hours, over 90 per cent of these lamps

will still be functioning after 500 burning hours. At 750 hours, over 70 per cent will have survived. At points near the design life or average life of the group of lamps, the failures occur more rapidly because, of course, the majority of them will burn out near the design life. A few lamps will continue to burn considerably beyond the point of 100 per cent life, compensating for those few which burned out earlier.

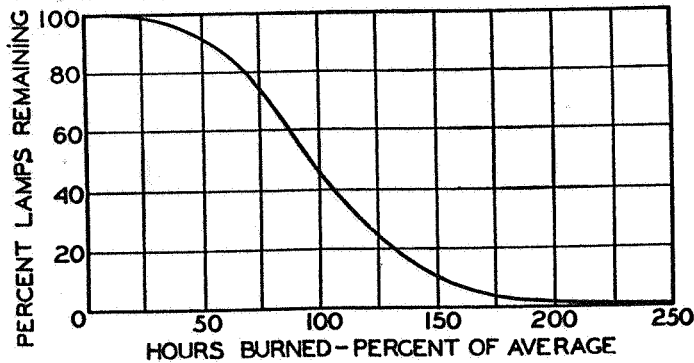

Fig. 36.

Mortality Curve of Lamps Showing Life Expectancy at Any Stage of Average Life.

The general shape of this curve is entirely dependent upon the laws of chemistry and electricity. It is affected by the ability of the lamp manufacturer to make lamps according to the designs laid down by the engineers. It is also, of course, influenced by the conditions under which the lamps operate.

The effect of voltage variation and vibration which are met in signal service has not been accurately determined. Data available indicate that in signaling service, both of these factors will have relatively little effect on the life expectancy of those lamps which are destined to fail prior to the "design life" of the group. They will probably cut off the life of lamps which on laboratory life tests continue to burn far beyond the 100 per cent point.

The best time for lamp renewal depends upon the operating conditions of the railroad. Where the traffic is relatively heavy, naturally outages are more serious. Also, where the cost of lamp renewals required by unexpected burn-outs is high, these outages should be kept to a minimum and, consequently, renewals should be made earlier in the life of the group of lamps installed. The design of the signaling system also has an important bearing on the ideal time for lamp renewals. Where stand-by lamps are used in the signal or where the burn-out of one or more lamps will not cause a signal failure, it is less vital that lamp renewals be made early. These factors must be carefully analyzed.

The peculiar shape of the mortality curve, however, makes it possible to select an approximate renewal point which will apply universally in spite of the various methods of signal operation and the different designs of signals now in use. This curve has a decided "knee" at 50 per cent life. Up to that point, only a few of the lamps will have failed and after that point, failures start to occur at a rapidly increasing rate. It can, therefore,

be recommended with confidence that all incandescent lamps for signal service be renewed at or just before this sharp downward bend in the mortality curve. Faithful execution of such a lamp renewal schedule will, over a period of years, reduce the signal failure due to lamp burnouts to about one-tenth the number which would be obtained if the lamps were left in the signals until they burned out.

Instructions.

Electric lamps should be maintained and tested in accordance with the following instructions:

1. Lamps must be replaced in kind.
2. Lamps must be inspected as instructed to see that they burn properly.
3. Receptacle and base of lamp must be clean to insure proper contact.
4. Care must be exercised when applying candelabra bayonet base type lamps to see that the pins in the base are turned to the end of the slots in the receptacle and forced into place by the contact spring.
5. Applied voltage must not exceed the rated voltage of the lamps and should not be higher than that necessary to insure good indication.
6. Lamps should be replaced in accordance with Table of Life Hours for Lamps but should not be left in service longer than 5 years.
7. Lamps should be tested prior to or when installed to determine their fitness for use. To test lamp, apply voltage of not less than 90 per cent nor more than rated lamp voltage for a period of 10 minutes. If the filament burns excessively bright or, after being burned, filament has lost its shiny appearance or bulb is discolored, the lamp should not be used.
8. Defective lamps, or lamps which fail short of time shown in Table of Life Hours for Lamps should be sent to proper authority with performance record.
9. Lamps must be stored in a clean dry place.
10. Where practicable, signal lenses, roundels, and reflectors should be cleaned without removing lamp.
11. Voltage reading at lamp must be taken each time lamp is replaced.
12. When double-filament lamps are used, they must be replaced when one filament fails.
13. Double-filament lamps must be installed in accordance with manufacturer's instructions.
14. New lamps should be handled as little as possible before placing in service. Jarring should be avoided so that filaments will not be distorted.

TABLE OF LIFE HOURS FOR LAMPS

(Based on average laboratory life of 1000 hours at rated voltage)

6-volt lamps		8-volt lamps		10-volt lamps		60-volt lamps		115-volt lamps	
Applied voltage	Hours	Applied voltage	Hours	Applied voltage	Hours	Applied voltage	Hours	Applied voltage	Hours
4.8	7700	6.4	7700	8.0	7700	48	7700	92	7700
4.9	5915	6.5	6400	8.1	6650	49	6000	93	6850
5.0	4230	6.6	5570	8.2	5600	50	4300	94	5900
5.1	2890	6.7	3800	8.3	4550	51	2890	95	5050
5.2	2080	6.8	2890	8.4	3500	52	2080	96	4130
5.3	1560	6.9	2180	8.5	2890	53	1560	97	3320
5.4	1310	7.0	1780	8.6	2390	54	1310	98	2800
5.5	1040	7.1	1470	8.7	1950	55	1020	99	2300
5.6	820	7.2	1310	8.8	1620	56	820	100	1950
5.7	650	7.3	1100	8.9	1430	57	650	101	1730
5.8	510	7.4	920	9.0	1310	58	510	102	1500
5.9	420	7.5	770	9.1	1140	59	410	103	1370
6.0	350	7.6	650	9.2	970	60	350	104	1220
6.1	295	7.7	530	9.3	870	61	300	105	1090
6.2	240	7.8	465	9.4	740	62	250	106	950
6.3	200	7.9	400	9.5	650	63	200	107	870
		8.0	350	9.6	550			108	760
		8.1	315	9.7	490			109	675
		8.2	275	9.8	440			110	590
		8.3	230	9.9	390			111	520
		8.4	200	10.0	350			112	470
				10.1	320			113	430
				10.2	290			114	385
				10.3	250			115	350
				10.4	220			116	320
				10.5	200			117	300
								118	270
								119	240
								120	210

This is based upon an average of 5 per cent or less lamps failing. The voltage must be measured at the lamp. Any period of excessive over-voltage will greatly reduce lamp life.