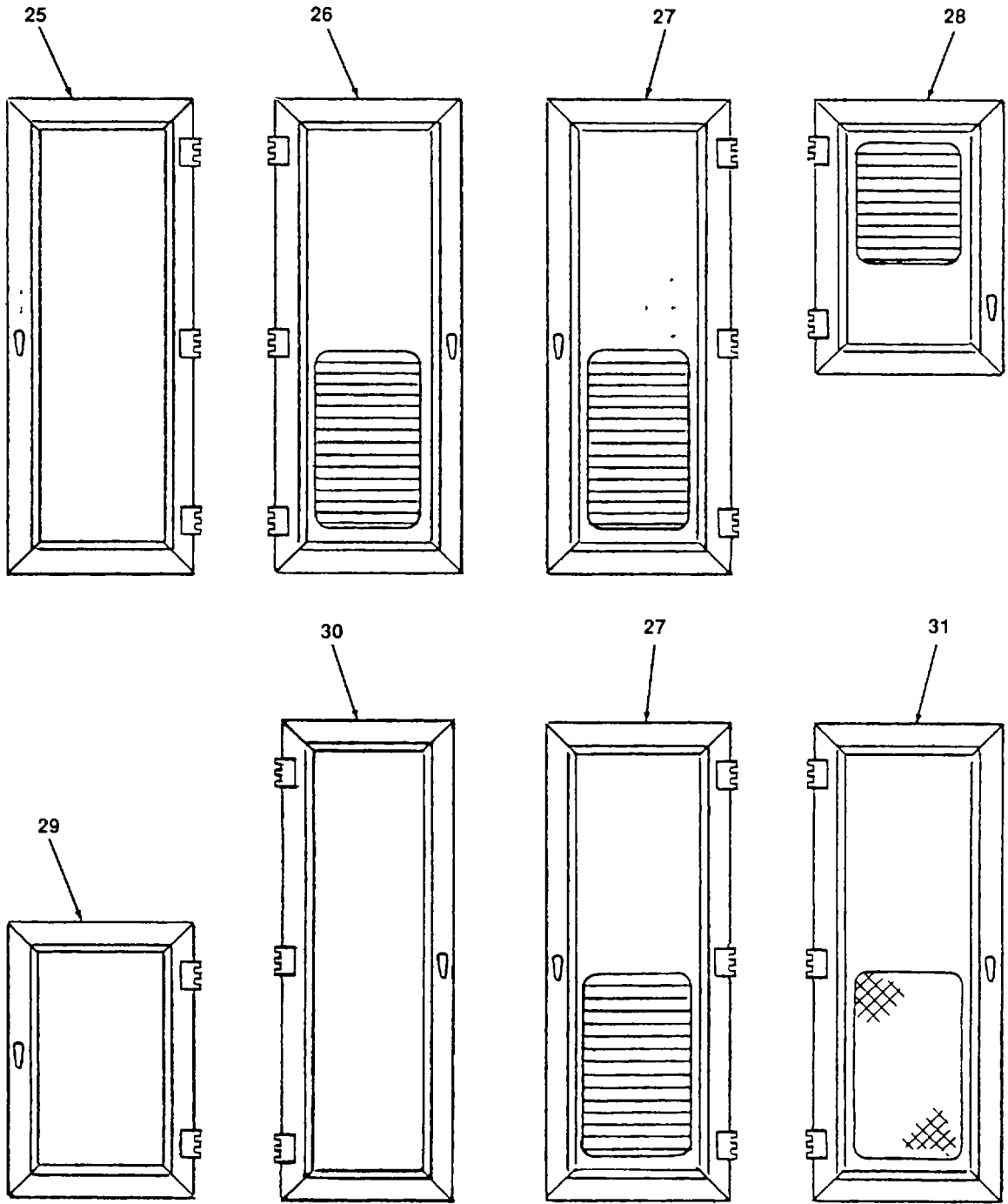

Figure 1. Engine Access Door (Sheet 1 of 2).



4834 001 2

Figure 1. Engine Access Door (Sheet 2 of 2).

(1) ITEM NO.	(2) FSCM	(3) PART NUMBER	(4) DESCRIPTION AND USABLE ON CODE	(5) QTY
			GROUP 01 BODY GROUP	
			FIG. 1 DOOR ENGINE HOOD	
1			PIN, HINGE (QTY 2 ON DOORS 28 AND 29)	3
2	96906	MS51967-06	NUT, HEX 5/16-18 UNC	9
3	96906	MS35338-45	WASHER, LOCK 5/16	9
4	96906	MS90725-44	SCREW, HEX 5/16-18 UNC, 3 IN LONG	9
5			HINGE (QTY 2 ON DOORS 28 AND 29)	3
6			HINGE, COMPRESSOR DOOR (WELDED)	2
7			SPRING	2
8	96906	MS27183-18	WASHER, FLAT 1/2 IN	2
9			SCREW, PAN HEAD 1/4 IN X 1/2 (NSN 5305-00-958-0609)	2
10	96906	MS35338-44	WASHER, LOCK 1/4 IN	8
11			BAR, LATCH, UPPER	1
12			BAR, LATCH, LOWER	1
13			BAR, LATCH, UPPER (DOOR 29 ONLY)	1
14			BAR, LATCH, LOWER (DOOR 28 ONLY)	1
15			BAR, LATCH, LOWER (DOOR 28 ONLY)	1
16			BAR, LATCH, LOWER (DOOR 29 ONLY)	1
17	96906		PIN, COTTER 3/32 X 1 IN (NSN 5315-00-816-1794)	1
18	96906		NUT, CASTLATED, 1/2 IN (NSN 5310-00-017-2941)	1
19	96906	MS27183-18	WASHER, FLAT, 1/2 IN	1
20			LEVER	1
21			HANDLE, DOOR	1
22	96906	MS51967-03	NUT, HEX, 1/4 IN	6
23	96906	MS90725-8	SCREW, HEX, 1/4 IN	6
24			BRACKET, FIRE EXTINGUISHER	1
25			DOOR, SOLID PANEL, HINGED RIGHT	2
26			DOOR, W/LOUVER PANEL, HINGED LEFT	2
27			DOOR, W/LOUVER PANEL, HINGED RIGHT	2
28			DOOR, SHORT, HINGED RIGHT	2
29			DOOR, COMPRESSION ACCESS	2
30			DOOR, NARROW, HINGED LEFT	2
31			DOOR, W/STRETCHED METAL SCREEN, HINGED LEFT	2
			END OF FIGURE	