

Figure 163. Main Air Piping (Sheet 1 of 2).

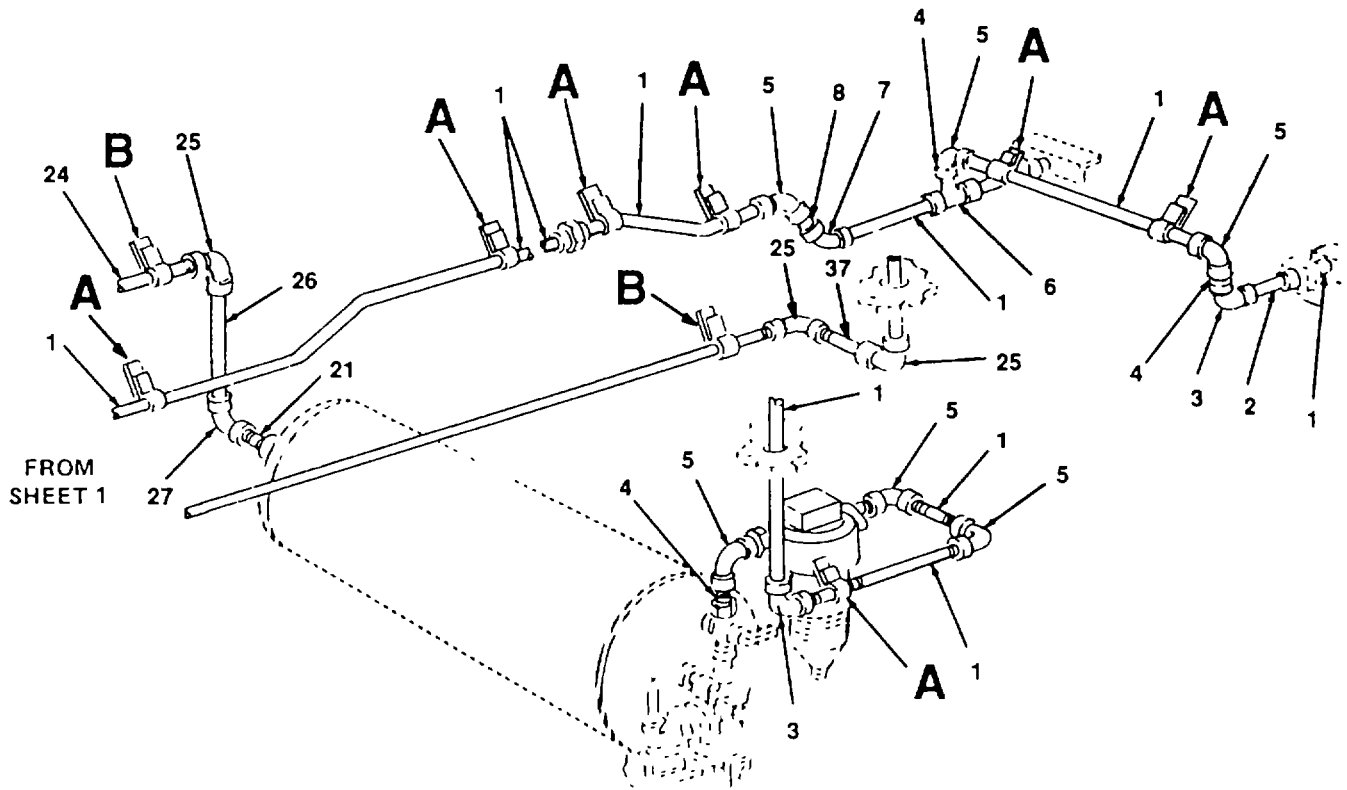

Figure 163. Main Air Piping (Sheet 2 of 2)

| (1) ITEM NO. | (2) FSCM | (3) PART NUMBER | (4) DESCRIPTION AND USABLE ON CODE | (5) QTY |
|--------------------|-------------|-----------------------|---------------------------------------|------------|
| | | | GROUP 24 PIPING SYSTEMS | |
| | | | FIG. 163 MAIN AIR PIPING | |
| 1 | 72423 | ASTM-A120 | PIPE, BLACK, SCHED 80, 1 IN | V |
| 2 | 96906 | MS51873-126B | NIPPLE, BLACK PIPE, 1 X3 IN | 7 |
| 3 | 72423 | 1643-200 | ELBOW, UNION, BLACK, 90 DEGREE | 1 |
| 4 | 96906 | MS51873-121-B | NIPPLE, BLACK PIPE, CLOSE, 1 IN | 7 |
| 5 | 72423 | 1201-200 | ELBOW, BLACK, 90 DEGREE, 1 IN | 11 |
| 6 | 72423 | 1647-200 | TEE, UNION, FEMALE RUN, 1 IN | 4 |
| 7 | 72423 | 1203-200 | ELBOW, STREET, BLACK, 90 DEGREE, 1 IN | 4 |
| 8 | 96906 | MS51873-130B | NIPPLE, BLACK PIPE, 1 X 5 IN | 2 |
| 9 | 96906 | MS31967-9 | NUT, HEX, 3/8 IN | 13 |
| 10 | 96906 | MS35338-46 | WASHER, LOCK, 3/8 IN | 13 |
| 11 | 96906 | MS90725-64 | SCREW, HEX, 3/8 X 1 1/2 IN | 13 |
| 12 | 96906 | MS35140-14 | CLAMP, SINGLE PIPE, 1 IN | 13 |
| 13 | 96906 | MS51873-131B | NIPPLE, BLACK PIPE, 1 X 5 1/2 IN | 1 |
| 14 | 96906 | MS51873-125B | NIPPLE, BLACK PIPE, 1 X 2 1/4 IN | 1 |
| 15 | 96906 | MS51873-127B | NIPPLE, BLACK PIPE, 1 X 3 3/4 IN | 1 |
| 16 | 72423 | 2071-397 | REDUCER, BUSHING, 2 TO 1 IN | 2 |
| 17 | 72423 | 1221-400 | TEE, BLACK PIPE, 300 PSI, 2 IN | 2 |
| 18 | 96906 | MS51873-128B | NIPPLE, BLACK PIPE, 1 X 4 IN | 1 |
| 19 | 96906 | MS51967-15 | NUT, HEX, 1/2 IN | 7 |
| 20 | 96906 | MS35338-48 | WASHER, LOCK, 1/2 IN | 7 |
| 21 | 96906 | MS90725-115 | SCREW, HEX, 1/2 X 2 IN | 7 |
| 22 | 97403 | 13228E2142-27 | CLAMP, SINGLE PIPE, 2 IN | 7 |
| 23 | 72423 | 1641-400 | UNION, BLACK PIPE, 300 PSI, 2 IN | 2 |
| 24 | 72423 | ASTM-A53 | PIPE, BLACK, SCHED 80, 2 IN | V |
| 25 | 72423 | 1201-400 | ELBOW, BLACK, 90 DEGREE, 2 IN | 5 |
| 26 | 96906 | MS51873-1938 | NIPPLE, BLACK PIPE, CLOSE, 2 IN | 2 |
| 27 | 72423 | 1643-400 | ELBOW, UNION, 90 DEGREE, 2 IN | 4 |
| 28 | 96906 | MS51873-197B | NIPPLE, BLACK PIPE, 2 X 4 IN | 1 |
| 29 | | | COUPLING, PIPE, 2 IN | 1 |
| 30 | 96906 | MS90725-172 | SCREW, HEX, 5/8 X 4 IN | 6 |
| 31 | 96906 | MS35338-50 | WASHER, LOCK, 5/8 | 6 |
| 32 | 97403 | 13228E2142-50 | CLAMP, CONDENSOR PIPE, 4 POSITION | 1 |
| 33 | 97403 | 13288E2142-51 | CLAMP, CONDESOR PIPE, 3 POSITION | 1 |