

LOCOMOTIVE SPECIFICATIONS

**GENERAL MOTORS
MODEL SW 1001
1000 HP DIESEL-ELECTRIC
SWITCHING LOCOMOTIVE**

Electro-Motive Division
La Grange, Illinois



INDEX



	<u>SECTION</u>
GENERAL INFORMATION AND IDENTIFICATION	1
CARBODY CONSTRUCTION	2
TRUCKS	3
POWER PLANT AND TRANSMISSION ENGINE, GENERATOR, COOLING AND LUBRICATING SYSTEMS	4
AIR BRAKES	5
EQUIPMENT	6
LOCOMOTIVE MODIFICATIONS	7
PAINTING	8
PERFORMANCE DATA	9
GENERAL OUTLINE	10

SECTION 1

GENERAL INFORMATION AND IDENTIFICATION



MODEL	SW1001 (Type 0440) 1000 H.P., 115 Ton Switcher.	
ARRANGEMENT	The general arrangement of the locomotive is shown on Elevation and Floor Plan Drawing attached.	
NOMINAL DIMENSIONS	Track gauge	4' 8-1/2"
	Length over coupler pulling faces	44' 8"
	Width over side sills	10' 0"
	Maximum height above rail	14' 3"
	Width of operator's cab	10' 0"
	Width of power plant compartment	6' 0"
	Wheelbase — truck	8' 0"
	Truck centers	22' 0"
	Number of drivers	4 Pairs
	Diameter of drivers	40"
	Size of journals	6-1/2" x 12"
GEAR RATIO	Gear ratio	62:15
CAPACITY	Starting T.E. at	
	25% adhesion (approximately)	57,500 lbs.
	30% adhesion (approximately)	69,000 lbs.
WEIGHTS AND SUPPLIES	Total loaded weight on rails (approximately)	230,000 lbs.
	Fuel	600 gal.
	Sand	30 cu. ft.
	Cooling water	190 gal.
	Lubricating oil	135 gal.
CLEARANCES	Locomotive outline drawing found in rear of specification book illustrates clearance conditions.	
SAFETY APPLIANCES	All steps, grab handles and other safety appliances cover EMD interpretation of Interstate Commerce Commission requirements.	

SECTION 1

General Information And Identification



**CURVE
NEGOTIATION**

Truck swing limits single unit curve negotiation to a 60° or 100 ft. radius curve.

Two units coupled are limited by truck swing to a 60° or 100 ft. radius curve.

Locomotive coupled to a 50 ft. car is limited by coupler swing to a 31° or 195 ft. radius curve.

SECTION 2 CARBODY CONSTRUCTION



FRAMING	Underframe is of all welded construction and serves as main carrying member for hood, cab and equipment. Draft gear pockets are welded to underframe structure.
UNDERFRAME CENTER BEARINGS	Welded to underframe.
COUPLERS	Type "E" of standard length with 6-1/4" x 8" shank and quadruple shear pin. Maximum swing of coupler is 25° each side of center. Centerline of coupler is 34" above rail.
UNCOUPLING DEVICE	Each end of the locomotive is provided with a top operating device arranged to operate from either side of the locomotive.
DRAFT GEAR	National Castings MS-485-6A rubber draft gear.
JACKING PADS	Four combination jacking pads and cable slings are provided, integral with the underframe opposite front and rear bolster.
FOOT BOARDS	Side foot boards and platform mounting steps are provided at each corner of the locomotive.
HANDRAILS	Long hood handrails are underframe mounted.
SIDE BEARINGS	Side bearing clearances of 1/4" on the front truck and 1/2" on the rear truck are provided.
CAB	The single operator's cab is of fabricated steel construction. Side windows for operator and helper are the sliding, double sash type, and are fitted with latches. Front and rear doors are provided.
WINDOWS	All windows and doors are provided with safety plate glass. The rear windows are protected by guard bars.
DOORS	A main center door is located at the rear of the cab, and a door at the front left side permits access to the walkway around the engine hood. Both doors are of fabricated steel construction.

SECTION 2

Carbody Construction



DOOR LOCKS The main cab door is equipped with a lock, and the front door is fitted with an inside latch.

INSULATION Ceiling is lined with perforated metal, backed up by insulation.

BATTERY BOX An all steel box is mounted outside of the platform at the rear of the cab. Construction incorporates ventilation, and drainage. Batteries are easily accessible by means of hinged covers on the boxes.

HOOD The power plant compartment has been designed to a minimum height and width to provide adequate vision from within the cab, as well as a runway around the hood. The sides are in effect made up of continuous double doors which permit complete accessibility to the power plant equipment by means of the walkway. The hood can be removed as an individual unit. A removable hatch is provided above the auxiliary generator.

ENGINE HATCHES Hinged covers are located over the engine to facilitate inspection and removal of cylinder heads, liners, engine filters, pistons and other components.

HOOD DOORS All side doors have outside hinges and latches.

LIFTING EYES Provision is made for lifting eyes on hood and hatches to facilitate handling with a crane.

SECTION 3

TRUCKS



TRUCK ASSEMBLIES

Two EMD design four-wheel, two motor trucks are provided per locomotive. The truck frames are cast steel, pedestal type, with integral side frames, hollow bolster, pedestal jaws, side bearings, and center plate. Truck frames are supported on double helical and semi-elliptic springs in parallel, with provision for adjustment of height. The semi-elliptic springs on each side of the truck are supported on hangers mounted between two forged equalizers, which in turn are supported on the journal boxes.

The truck bolsters, which are cast integral with the truck frames, carry large center plates with hollow center to provide for introduction of clean air from within the superstructure to the traction motors.

Four forged equalizers are provided per truck, and are machined at the journal box contacts.

Each of the four traction motors is supported in the trucks between a driving axle and a flexible motor nose suspension on the truck bolster.

AXLES

The axles conform to physical properties of current A.A.R. material specification.

WHEELS

All wheels are rolled or cast steel and heat treated. Wheel has a diameter of 40" and width of 5-1/2" at the tread.

JOURNAL BOXES

Locomotive equipped with Timken class "F" 6-1/2" x 12" cartridge type tapered roller bearings (applicable to locomotive with weight not exceeding 235,000 lbs. nominal).

PEDESTAL LINERS

Spring steel channel section welded to pedestals.

PEDESTAL TIE BARS

Fitted and applied at the lower end of the pedestal legs, held in position by bolts.

SECTION 3
Trucks



**TRUCK CENTER
BEARING
RECEPTACLE**

Truck center bearing receptacle provided with wear plates and rubber dust guard.

SIDE BEARINGS

Friction type side bearings.

HAND BRAKE

Hand brake provided for the locomotive connected to one brake cylinder lever. All trucks provided with lever for hand brake connection, making trucks interchangeable. Hand brake is cab mounted.

INTERLOCKS

Body and truck interlocks provided each side of the center plate, serving as antisluing device in case of derailment.

SECTION 4

POWER PLANT AND TRANSMISSION



ENGINE	G.M. Diesel eight cylinder, 2 cycle 45° V, 9-1/16" bore, 10" stroke, unit injection, Roots blower scavenging through cylinder wall intake, and multi-valve exhaust. Water cooled cylinder liners and heads, oil cooled pistons, five bearing crankshaft, drop forged connecting rods and floating piston assembly. Isochronous governor speed control and separate overspeed trip. Engine shipped without lubricating oil.
MAIN GENERATOR	EMD self ventilated, nominal 600 volt direct current generator. Single outboard bearing armature, direct connection to engine crankshaft through a flexible coupling. Capacity suitable to continuously transmit to traction motors the rated output of the engine under all conditions for which the locomotive is offered.
LOAD CONTROL	Load control provided to automatically maintain horsepower output in accordance with the published tractive effort characteristics of the locomotive.
TRACTION MOTORS	Four EMD direct current, series wound, forced ventilated, axle hung motors with roller type armature bearings.
TRACTION MOTOR BLOWER	Single traction motor blower driven from engine provides air for all traction motors, through ducts built into underframe.
AUXILIARY GENERATOR	Direct current generator, driven from engine gear train, provides current for control circuits, lighting, battery charging, and separate excitation of main generator. Voltage automatically controlled by static voltage regulator.
ENGINE STARTING	By motoring of the main generator through use of special starting field energized by the locomotive storage battery. Engine start switch at governor end of engine.
STORAGE BATTERY	32 cell, 64 volt, 284 ampere hour (8 hour rating) battery located back of cab.
ENGINE COOLING	Circulation system consists of direct driven centrifugal water pump; forced air circulation through fin tube radiators, and separate water supply tank. Temperature control by automatically operated shutters.

SECTION 4

Power Plant And Transmission



ENGINE LUBRICATION

The engine lubricating oil system is a pressure system using two positive displacement gear type pumps combined in a single unit. One pump delivers oil for the pressure lubricating system, the other for piston cooling. The oil supply to these pumps is drawn from the oil strainer chamber through a common suction pipe.

A scavenging oil pump is used to draw oil from the engine oil pan through a strainer, pump it through the lube oil filter to the cooler core section of the cooler tank and return it to the strainer chamber. Low oil pressure and high oil temperature protection are provided resulting in engine shutdown.

ENGINE EXHAUST

Single exhaust muffler.

ENGINE FUEL SYSTEM

Return flow, single DC motor driven gear pump, protected by suction strainer, and increased capacity discharge filters to insure clean fuel for the engine. Sight glasses permit visual inspection of fuel flow, and relief valve offers protection against excessive pressures.

FUEL TANK

600 gallon capacity fuel tank built of heavy gauge steel, with baffle plates, located underneath the locomotive body. One filling station on each side. Tank equipped with venting, cleanout plug, and nonremovable water drain.

Direct reading type fuel sight glasses with gallonage calibration plates on both sides of tank. Each filling station provided with electric emergency fuel cutoff actuating button. Similar pushbutton located in cab. When operated, engine stops immediately.

ENGINEER'S CONTROL STATION

Engineer's control station located conveniently to the left of the engineer's seat, includes the engine speed throttle, locomotive reverse lever and selector switch for switching from permanent series to automatic forward transition. Automatic and independent brake valves. The lever arrangements are such that the throttle must be in idle before the reverse lever can be removed to isolate the controller. The horn, bell, and independent sander valves are also located in the control stand.

ENGINEER'S CONTROL SWITCHES

Control and lighting switches are located within reach of the engineer including switches for control and fuel pump, generator field, engine run, gauge lights, headlight "bright" front and rear and "dim" front and rear. Cab heater switches are located on cab heaters, providing individual control.

ENGINEER'S INSTRUMENT PANEL

A lighted instrument panel is provided on top of engineer's controller containing air brake gauges. Hot engine indicator, ground relay light and reset button are located on the front cab wall.

SECTION 4

Power Plant And Transmission



TRUCK CUTOUT A switch is provided to cutout the traction motors by truck.

**ELECTRICAL
CONTROL
CABINET** Electrical equipment cabinet located at front cab partition includes, switch and fuse panel and engine control panel.

SECTION 5

AIR BRAKES



- AIR BRAKES** 26NL brake schedule including self-lapping automatic and independent brake valves and 6NR distributing valve.
- FOUNDATION BRAKES** Four 10" x 6" double-acting cylinders with standard A.A.R. brake shoes provided.
- MAIN RESERVOIR** Two 22-1/2" diameter x 84-3/4" steel reservoirs mounted beneath the underframe. Total capacity: 49,000 cu. in. Manual main reservoir drain valves provided. Reservoirs drilled with tell tale holes.
- AIR COMPRESSOR** One two stage, three cylinder, water cooled direct coupled compressor, having a displacement of 254 cu. ft. per minute at 900 RPM. Compressor is provided with large oil capacity and disposable intake air filter.
- Electric air compressor governor adjusted to maintain reservoir pressure between 130 and 140 psi.
- SANDING** Manual sanding is controlled pneumatically. One sander valve operates four sand traps, two traps for forward movement and two traps for reverse movement.

SECTION 6

EQUIPMENT



CAB HEATERS	Hot water cab heater with fan driven circulating system including three speed switch for fan speed control.
WINDOW WIPERS	Total of four air operated window wipers are provided for front and rear windows on both sides of cab and center windshields.
SUN VISORS	Total of four adjustable metal sun visors are provided.
CAB SEATS	The two wall mounted upholsered cab seats have forward and backward as well as height adjustments. Both seats can be turned 180 degrees.
FIRE EXTINGUISHERS	Two 20 lb. Ansul dry powder extinguishers are provided, one located in cab, the other in the engine compartment.
HEADLIGHT	Twin sealed-beam headlights, front and rear, are equipped with two 200 watt, 30 volt sealed beam units. Bright and dim switch for each light provided in operator's cab.
WARNING DEVICES	Consist of: <ol style="list-style-type: none">1. One 12" bell operated by internal pneumatic type ringer.2. One diaphragm type air horn.
LOCOMOTIVE LIGHTING	Lights and outlets are as follows: <ol style="list-style-type: none">1. Two ceiling cab lights2. One engine room light3. Two ground lights4. Three gauge lights5. Two outlet receptacles, one in cab, one in engine room
MARKER AND FLAG BRACKETS	Four standard combination flag and light brackets are provided, two each are located at front and rear of locomotive.

SECTION 7 LOCOMOTIVE MODIFICATIONS



The following modifications can be supplied on request to satisfy various operating requirements. The base price of the locomotive described in this specification does not include these modifications.

MULTIPLE CONTROL	Multiple control equipment available to allow operation of two or more units from one cab. Locomotive equipped with one 27 point power plant receptacle per end, and one power plant jumper cable. Sanding control can be trainlined electrically, pneumatically or both.
AIR COMPRESSOR	Two stage, six cylinder air compressor, water cooled, having a displacement of 401 cu. ft. per minute at 900 RPM.
AWNINGS	Cloth or metal awnings over cab windows can be provided.
FUEL TANK	1000 gallon fuel tank is available.
WIND DEFLECTORS	Wind deflectors can be provided at front and rear of side windows.
SPEED RECORDER	Speed recorder or speed indicator available with splined axle drive.
BATTERY CHARGING RECEPTACLE	Battery charging receptacle can be provided.
CARBODY AIR FILTERS	Air filters can be provided in engine hood for generator, engine, and traction motor air.
DUAL CONTROL	Mechanically connected duplex control stations available.
P.C. SWITCH	A pneumatic control (P.C.) switch may be provided to reduce the power output of the locomotive.

SECTION 7

Locomotive Modifications



- | | |
|--------------------------------|--|
| ROLLER BEARING JOURNALS | Timken class "G" 7" x 12" cartridge type tapered roller bearings available for locomotives with weight exceeding 235,000 lbs. nominal. |
| LAYOVER PROTECTION | Layover protection available using oil fired hot water heater or electric immersion heating element. |
| MOTOR SHUNTING | Traction motor field shunting to extend speed range over which full horsepower is available. |
| BALLAST | Locomotive can be ballasted to weigh 240,000 lbs. maximum within manufacturing tolerances. |
| SANDING | Inboard sanding can be provided. |
| NUMBER BOXES | Lighted number boxes at both ends available. |

SECTION 8

PAINTING



- OUTSIDE FINISH** Color arrangement and design to agree with railroad's requirement.
- ENGINE ROOM** Inside finished in suede gray. All air, fuel, water and lube oil piping color coded at points of connection.
- UNDER CARRIAGE** Black unless otherwise specified.
- CAB** Inside finished in suede gray.
- TRUCKS & TANKS** Black unless otherwise specified.

SECTION 9

PERFORMANCE

DATA



OPTIONAL GEAR RATIOS

The choice of gear combinations will depend upon the service contemplated. With the standard 62:15 gear ratio the locomotive develops 42,000 lbs. of tractive effort at the minimum continuous speed of 6.7 MPH. The maximum speed recommended for the switcher truck is 45 MPH.

HORSEPOWER RATING

The SW1001 locomotive develops 1000 nominal horsepower into the generator for traction at 900 RPM of the engine under the following conditions:

- 60°F air intake temperature
- 29.9 inches hg barometer (minimum)
- 0.845 specific gravity fuel
- .83 engine governor rack setting
- 60°F fuel temperature

SPECIFICATION AMENDMENT



Electro-Motive Division Locomotive Specification No. 8070 is amended to incorporate certain Remanufactured components, for replacement locomotives only.

The items listed below constitute the maximum number of Remanufactured components that may be incorporated in the SW1001 replacement locomotive.

ENGINE PARTS

- Lube oil pumps
- Blowers
- Crankshaft
- Camshafts
- Cam blocks
- Accessory drive housing
- Harmonic balancer
- Camshaft drive housing and cover

MAIN GENERATOR

- Frame and pole pieces
- Armature core, commutator, armature shaft
- Bearing housing and assembly parts

TRACTION MOTOR PARTS

- Frame assembly and pole pieces
- Armature core, commutator, armature shaft
- Bearing housings and assembly parts

TRUCK ASSEMBLY PARTS

- Frames, equalizers, and pedestal tie bars
- Coil and elliptic springs, spring hangers and coil spring seats
- Axles and axle gears
- Brake cylinders, brake levers, straps and slack adjusters

AUXILIARY GENERATOR

FUEL PUMP AND MOTOR

LOAD REGULATOR

1000 HP INDUSTRIAL

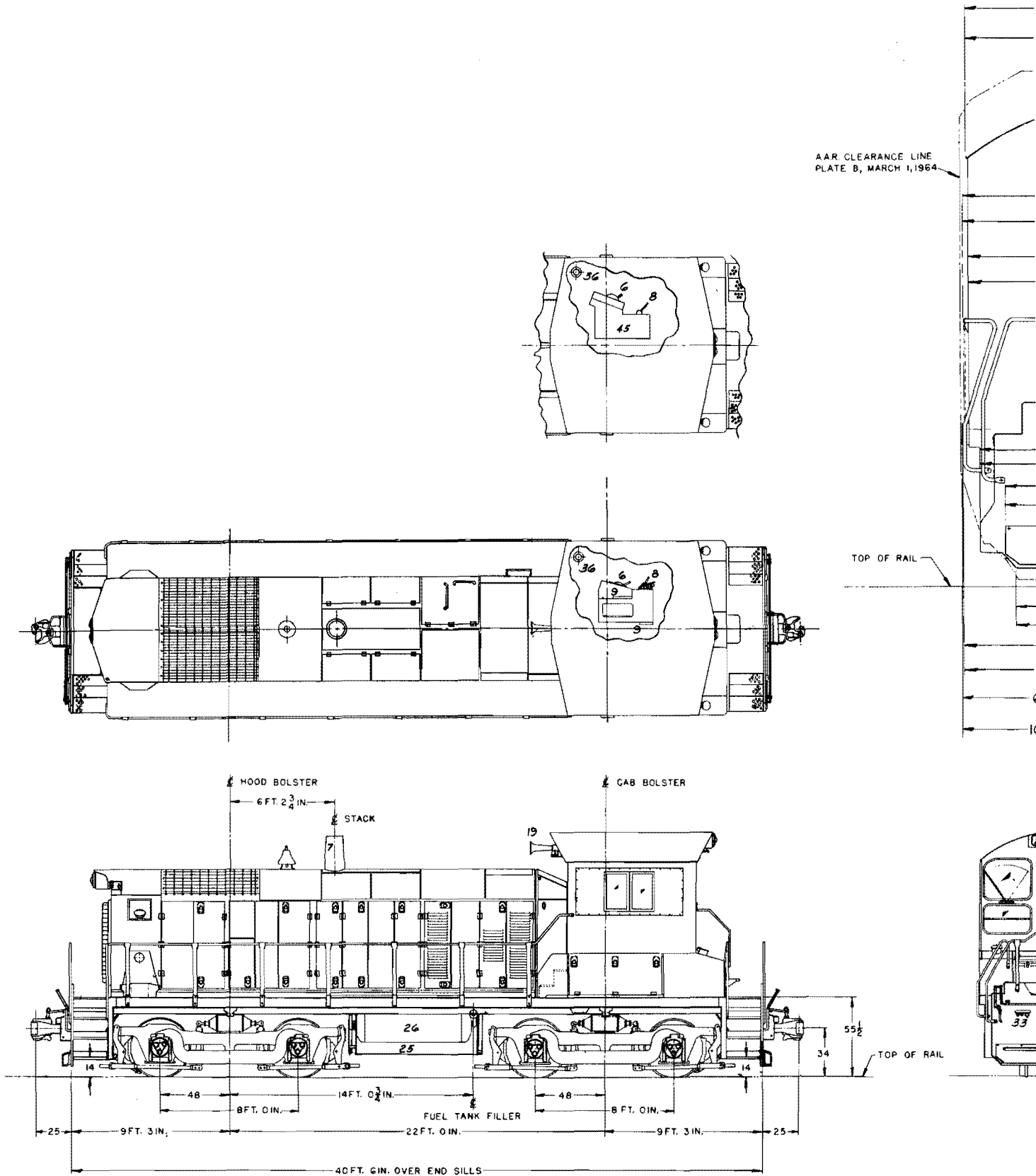

BASIC LOCOMOTIVE

1000 HP INDUSTRIAL SWITCHING LOCOMOTIVE - MOD

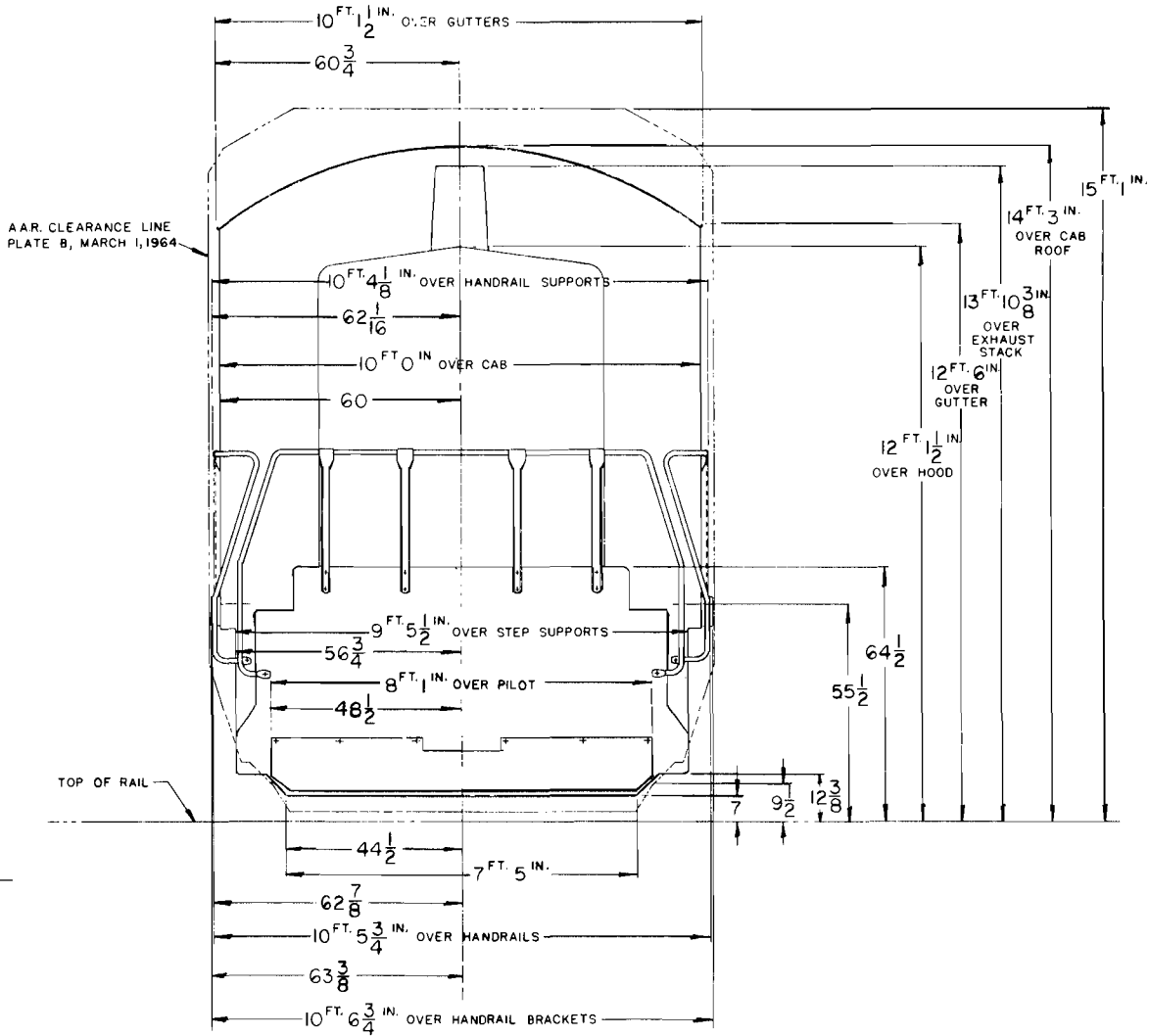

NOTE: LOCOMOTIVE HEIGHT TO
LOCOMOTIVE WIDTH TO
TRUCK LATERAL AT BC
LOCOMOTIVE IS SHOWN
NEW CONDITION, STAND

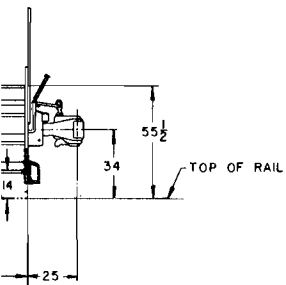
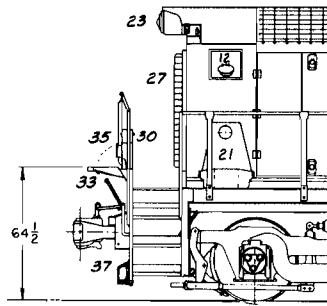
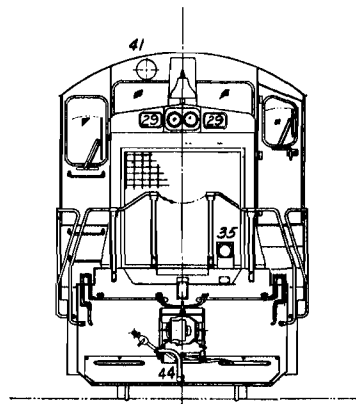
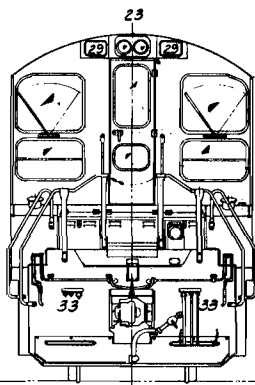
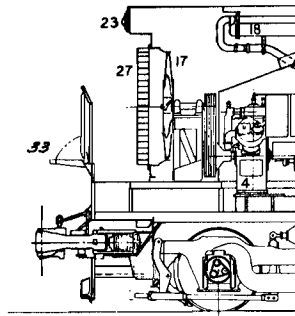
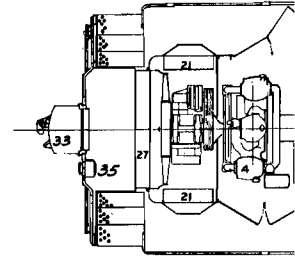

E - MODEL SW1001

LOCOMOTIVE HEIGHT TOLERANCE = 1-1/2 IN.
 LOCOMOTIVE WIDTH TOLERANCE = 1/2 IN.
 TRUCK LATERAL AT BOLSTERS = 1 IN. NOM. (FLEX. TRUCK ONLY)
 LOCOMOTIVE IS SHOWN INCLUDING HALF VARIABLE SUPPLIES AND IN
 NEW CONDITION, STANDING STILL ON LEVEL AND TANGENT TRACK.

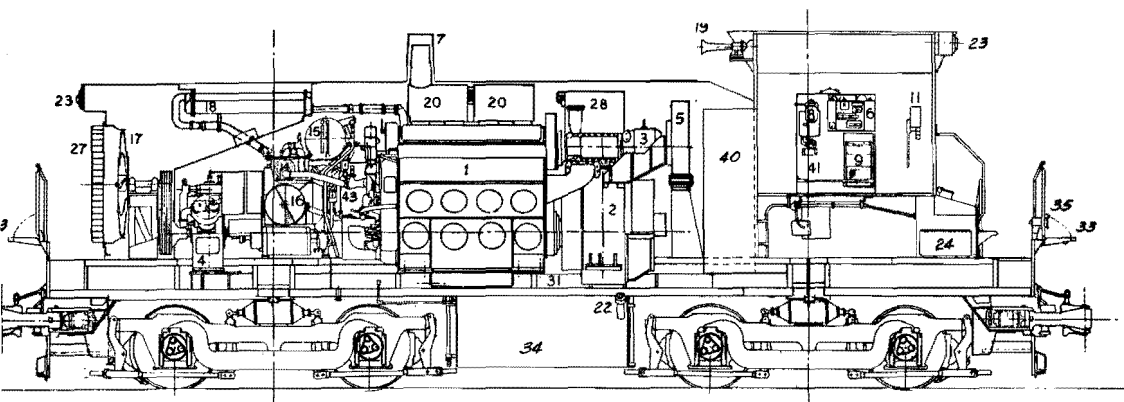
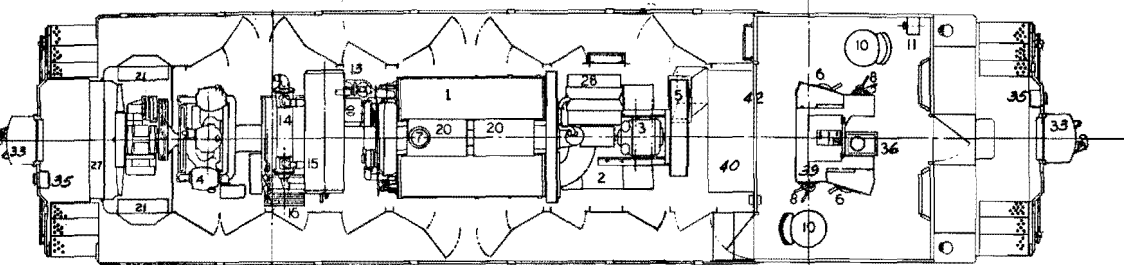

LOCOMOTIVE WITH EXTRAS

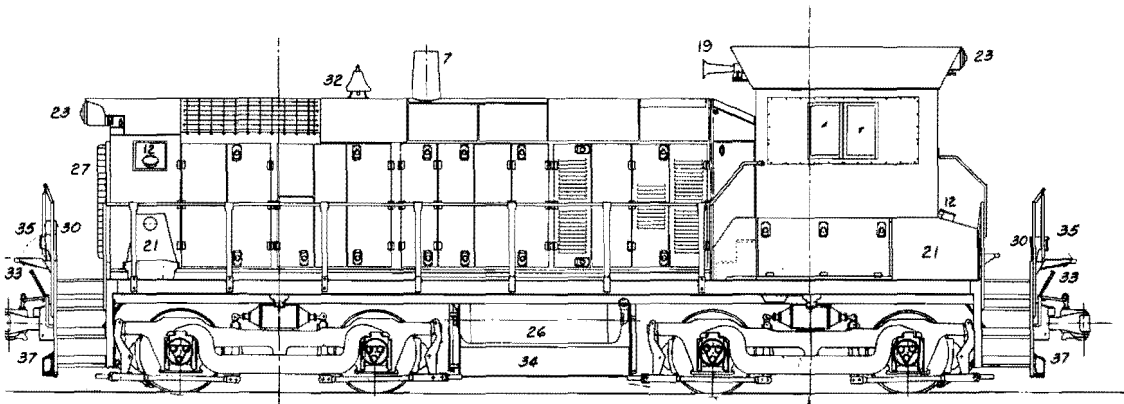

1. ENGINE - EMD MODEL 8-645E
2. MAIN GENERATOR
3. AUXILIARY GENERATOR 10 KW
4. AIR COMPRESSOR
5. TRACTION MOTOR BLOWER
6. ENGINEER'S CONTROL
7. EXHAUST STACK
8. AIR BRAKE VALVE
9. CAB HEATER
10. SLIDING SEAT
11. HAND BRAKE
12. SAND BOX FILLER
13. LUBE OIL FILLER
14. LUBE OIL COOLER
15. ENGINE WATER TANK
16. LOAD REGULATOR
17. FAN
18. RADIATOR
19. HORN
20. EXHAUST MANIFOLD
21. SAND BOX 30 CU. FT. TOTAL
22. FUEL FILLER
23. HEADLIGHT TWIN SEALED BEAM
24. BATTERIES
25. FUEL TANK 600 GALLONS
26. MAIN AIR RESERVOIR
27. AIR INLET & SHUTTERS
28. ENGINE AIR FILTER
- *29. NUMBER BOX
- *30. RAMP LIGHT
31. TRACTION MOTOR AIR DUCT
32. BELL
- *33. M.U. END ARRANGEMENT (GP-TYPE)
- *34. FUEL TANK 900 GALLONS
- *35. M.U. RECEPTACLE
- *36. WATER COOLER
37. PILOT & FOOTBOARDS
38. REF. NOT USED
- *39. DUPLEX CONTROLLER
40. ELECTRICAL CABINET
41. CAB VENTILATOR
42. ENGINE CONTROL PANEL
43. ENGINE START SWITCH
- *44. M.U. END ARRANGEMENT (SW-TYPE)
45. CONTROL HANDLE ARRANGEMENT (SW1200 TYPE)

*MODIFICATIONS

Electro-Motive Division
 La Grange, Illinois

