

TM 5-3895-379-10

TECHNICAL MANUAL

OPERATOR'S MANUAL

FOR

ROLLER, MOTORIZED, VIBRATING TANDEM STEEL DRUMS

CATERPILLAR MODEL CB534B (NSN 3895-01-396-2822)
CATERPILLAR MODEL CB534C (NSN 3895-01-502-4005)

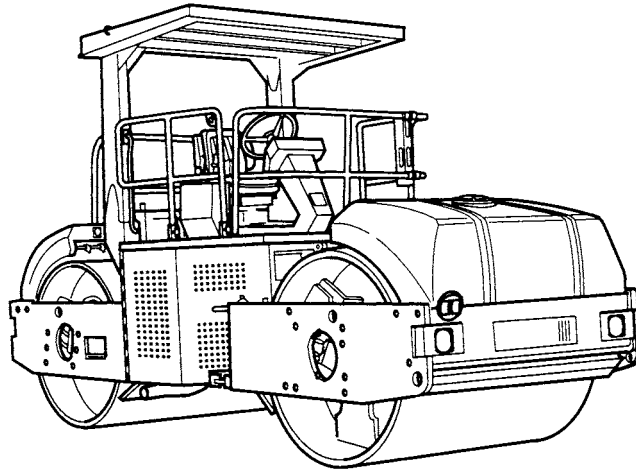

SUPERSEDURE NOTICE - This manual supersedes TM 5-3895-379-10, dated 27 March 2000.

DISTRIBUTION STATEMENT A - Approved for public release; distribution is unlimited.

HEADQUARTERS, DEPARTMENT OF THE ARMY

JULY 2005

WARNING SUMMARY

This warning summary contains general safety warnings and hazardous materials warnings that must be understood and applied during operation and maintenance of this equipment. Failure to observe these precautions could result in injury or death. Also included are explanations of safety and hazardous materials icons used within the technical manual.



BIOLOGICAL - abstract symbol bug shows that a material may contain bacteria or viruses that present a danger to life or health.



CHEMICAL - drops of liquid on hand shows that the material will cause burns or irritation to human skin or tissue.



EAR PROTECTION - Headphones over ears show that noise level will harm ears.



ELECTRICAL - electrical wire to arm with electricity symbol running through human body shows that shock hazard is present.



EYE PROTECTION - person with goggles shows that the material will injure the eyes.



FIRE - flame shows that a material may ignite and cause burns.

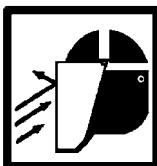

FLYING PARTICLES - arrows bouncing off face with face shield shows that particles flying through the air will harm face.



HEAVY PARTS - heavy object on human figure shows that heavy parts present a danger to life or limb.



HOT AREA - hand over object radiating heat shows that part is hot and can burn.



HYDRAULIC FLUID PRESSURE - hydraulic fluid spraying human figure shows that fluid escaping under great pressure can cause injury or death.



RADIOACTIVE - identifies a material that emits radioactive energy and can injure human tissue or organs.



VAPOR - human figure in a cloud shows that material vapors present a danger to life or health.

FOR INFORMATION ON FIRST AID, REFER TO FM 4-25.11.



WARNING

CARBON MONOXIDE (EXHAUST GASES) CAN KILL!

- Carbon monoxide is a colorless, odorless, deadly poison which, when breathed, deprives the body of oxygen and causes suffocation. Exposure to air containing carbon monoxide produces symptoms of headache, dizziness, loss of muscular control, apparent drowsiness, and coma. Permanent brain damage or death can result from severe exposure.
 - Carbon monoxide occurs in exhaust fumes of internal combustion engines. Carbon monoxide can become dangerously concentrated under conditions of inadequate ventilation. The following precautions must be observed to ensure safety of personnel when engine of tractor is operated.
1. DO NOT operate roller engine in enclosed areas without adequate ventilation.
 2. DO NOT idle roller engine without adequate ventilation.
 3. DO NOT drive roller with inspection plates or cover plates removed.
 4. BE ALERT for exhaust poisoning symptoms. They are:
 - Headache
 - Dizziness
 - Sleepiness
 - Loss of muscular control
 5. If you see another person with exhaust poisoning symptoms:
 - Remove person from area.
 - Expose to fresh air.
 - Keep person warm.
 - Do not permit physical exercise.
 - Administer cardiopulmonary resuscitation (CPR), if necessary.
 - Notify a medic.
 6. BE AWARE. The field protective mask for nuclear-biological-chemical (NBC) protection will not protect you from carbon monoxide poisoning.

The Best Defense Against Carbon Monoxide Poisoning Is Good Ventilation!

WARNING

ARTICULATION AREA HAZARDS

- There is no clearance for personnel between frame and yoke when roller turns. Severe injury or death from crushing could occur.
- Steering frame must be locked before lifting, transporting or servicing roller in articulation area with engine running, to prevent injury or death from crushing.
- Unlock steering frame before operation to prevent loss of steering that may cause injury or death.

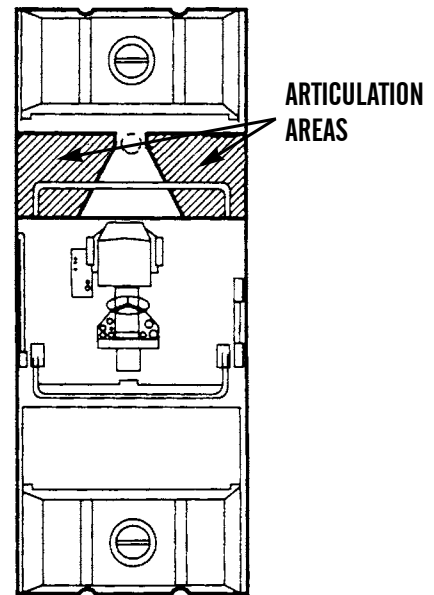

WARNING
BATTERIES



- To avoid injury, eye protection and acid-resistant gloves must be worn when working around batteries. Do not smoke, use open flame, make sparks or create other ignition sources around batteries. If a battery is giving off gases, it can explode and cause injury. Remove all jewelry such as rings, ID tags, watches, and bracelets. If jewelry or a tool contacts a battery terminal, a direct short will result in instant heating or electric shock, damage to equipment, and injury.
 - Sulfuric acid contained in batteries can cause burns. If battery corrosion or electrolyte makes contact with skin, eyes or clothing, take immediate action to stop the corrosive burning effects. Failure to follow these procedures may cause injury or death.
- Eyes.** Flush with cold water for no less than 15 minutes and seek medical attention immediately.
 - Skin.** Flush with large amounts of cold water until all acid is removed. Seek medical attention as required.
 - Internal.** If corrosion or electrolyte is ingested, drink large amounts of water or milk. Follow with milk of magnesia, beaten egg or vegetable oil. Seek medical attention immediately.
 - Clothing/Equipment.** Wash area with large amounts of cold water. Neutralize acid with baking soda or household ammonia.



WARNING

CLEANING COMPOUND, SOLVENT



Cleaning compound, solvent MIL-PRF-680 Type III is an environmentally compliant and low toxic material. However, it may be irritating to the eyes and skin. Use protective gloves and goggles. Use in well-ventilated areas. Keep away from open flames and other sources of ignition.

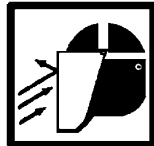

WARNING

COMPRESSED AIR

Particles blown by compressed air are hazardous. DO NOT exceed 15 psi (103 kPa) nozzle pressure when drying parts with compressed air. Use a maximum of 30 psi (207 kPa) when cleaning components. DO NOT direct compressed air against human skin. Failure to follow this warning may result in injury or death. Make sure air stream is directed away from user and other personnel in the area. To prevent injury, user must wear protective goggles or face shield.



WARNING

FUEL HANDLING

- DO NOT smoke or permit any open flame in area of machine while you are servicing fuel system. Be sure hose nozzle is grounded against filler tube during refueling to prevent static electricity. Failure to follow this warning may result in injury, or equipment damage.
- DO NOT perform fuel system checks, inspections or maintenance while smoking or near fire, flames or sparks. Fuel may ignite, causing injury, death or damage to roller.
- Wear fuel-resistant gloves when handling fuels and promptly wash exposed skin and change fuel-soaked clothing.



WARNING

HAZARDOUS WASTE DISPOSAL

When servicing this roller, performing maintenance or disposing of materials such as engine coolant, hydraulic fluid, lubricants, battery acids or batteries, consult your unit/local hazardous waste disposal center or safety office for local regulatory guidance. If further information is needed, please contact The Army Environmental Hotline at 1-800-872-3845.



WARNING

HEARING PROTECTION

- Your hearing can be PERMANENTLY DAMAGED if you are exposed to constant high noise levels of 85 DB or greater. Hearing protection is required when operating roller or when working on roller while it is operating. Failure to wear hearing protection may result in hearing loss.



WARNING
HEAVY PARTS

- Lifting equipment used for lifting machine must be in good condition and of suitable load capacity. Failure to follow this warning may result in injury, death or damage to roller.
- Improper use of lifting equipment and improper attachment to roller can result in injury, or equipment damage. Observe all standard rules of safety.
- Use caution when handling heavy parts. Provide adequate support and use assistance during procedure. Ensure that any lifting device used is in good condition and of suitable load capacity. Keep clear of heavy parts supported only by lifting device. Failure to follow this warning may cause injury or death.



WARNING
HOT COMPONENTS

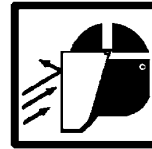

Hot oil or metal parts can cause burns. Wear insulated gloves, long sleeves and eye protection when working with heated parts.



WARNING
NBC EXPOSURE



- If NBC exposure is suspected, personnel wearing protective equipment must handle all air cleaner media. Consult your NBC Officer or NBC NCO for appropriate handling or disposal procedures.
- NBC contaminated filters must be handled using adequate precautions (FM 21-40) and must be disposed of by trained personnel.

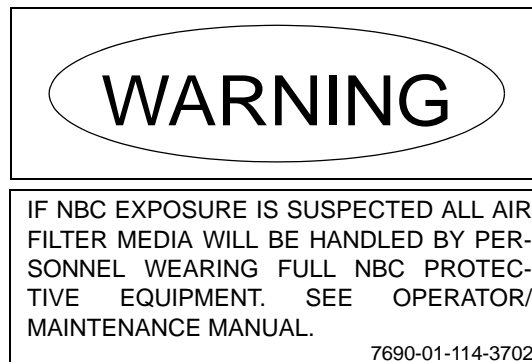

To order this NBC decal use:

National Stock Number (NSN) - 7690-01-114-3702
Part Number (PN) - 12296626
Commercial and Government Entity Code (CAGEC) - 19207



WARNING
PRESSURIZED COOLING SYSTEM



- DO NOT service cooling system unless engine has cooled. This is a pressurized cooling system and escaping steam or hot coolant may cause serious burns.
- DO NOT remove radiator cap when engine is hot. Allow engine to cool down. Loosen cap to first stop and let any pressure out of cooling system, then remove cap. Failure to follow this warning may cause burns.
- Wear effective eye, glove, and skin protection when handling coolants. Failure to do so may cause injury.



WARNING
ROLLER OPERATION

- Use caution and maintain three-point contact at all times when mounting or dismounting roller, to avoid injury or death.
- BE ALERT for personnel in the area while operating roller. Always check to ensure area is clear of personnel and obstructions before moving. Failure to follow this warning may result in injury or death.
- Use of seat belt while operating roller is mandatory. Fasten belt BEFORE operating. Trying to fasten belt while operating creates a hazardous condition. Failure to follow this warning may result in injury or death.
- DO NOT allow riders on roller. Failure to follow this warning may result in injury or death.
- Do not turn roller vibratory system on while roller is standing still on a very solid surface. A loss of steering can be experienced which could result in injury.



WARNING
SLAVE STARTING

- When slave starting machine, use NATO slave cable that DOES NOT have loose or missing insulation.
- DO NOT proceed if correct cable is not available.
- DO NOT use civilian-type jumper cables.



WARNING

TOWING ROLLER

- Before towing, ensure tow bar is in good working condition. Use of a weak tow bar could result in injury or death.
- Incorrectly towing a roller may cause injury or death.
- Do not allow an operator on roller unless engine is running and the operator can control steering and/or braking. Uncontrolled roller may cause injury or death.
- Do not use a chain or cable for pulling. A chain or cable link can break causing injury.
- The towing vehicle should be as large or larger than the roller. Any vehicle used to tow the roller shall have enough brake capacity, weight, and power to control both vehicles for the grade and distance involved.
- To provide sufficient control and braking when moving a disabled roller downhill, a larger towing vehicle, or additional vehicles, connected to the rear of the towed roller is required.
- Turning on a slope will reduce the stability of both the towing vehicle and the towed roller and could result in a tip-over accident.

WARNING

WHOLE BODY VIBRATION

Operator shall not operate roller for periods longer than 3 hours. Operator may resume 3 hour period of roller operation after 1 hour of rest. Operating roller for periods longer than 3 continual hours may cause injury to personnel from exposure to high whole body vibration levels.



WARNING

PROTECTIVE HEAD GEAR

Operators must wear protective head gear. Failure of operators to wear protective head gear may result in serious injury or death.

WARNING

OPERATION AND MAINTENANCE

Do not operate or maintain this machine unless you have read and understand the instructions and warnings in the operation and maintenance sections of this manual. Failure to follow the instructions or heed the warnings could result in injury or death.

LIST OF EFFECTIVE PAGES/WORK PACKAGES

Date of issue for original manual is:

Original 15 July 2005

TOTAL NUMBER OF PAGES FOR FRONT AND REAR MATTER IS 28 AND TOTAL NUMBER OF WORK PACKAGES IS 29 CONSISTING OF THE FOLLOWING:

Page/WP No.	*Change No.
Cover/(Back Blank)	0
a to h	0
A/(B Blank)	0
i to iv	0
WP 0001 00 to 0029 00	0
Index-1 to Index-4	0
DA Form 2028 Sample	0
DA Form 2028	0
Metric Conversion Chart	0
Back Cover	0

* Zero in this column indicates an original page or work package.

A/(B Blank)

OPERATOR'S MANUAL
FOR
ROLLER, MOTORIZED,
VIBRATING TANDEM STEEL DRUMS

CATERPILLAR MODEL CB534B (NSN 3895-01-396-2822)
CATERPILLAR MODEL CB534C (NSN 3895-01-502-4005)

REPORTING ERRORS AND RECOMMENDING IMPROVEMENTS

You can help improve this publication. If you find any mistakes or if you know of a way to improve the procedures, please let us know. Submit your DA Form 2028 (*Recommended Changes to Equipment Technical Publications*), through the Internet, on the Army Electronic Product Support (AEPS) website. The Internet address is <http://aeprs.ria.army.mil>. If you need a password, scroll down and click on "ACCESS REQUEST FORM". The DA Form 2028 is located in the ONLINE FORMS PROCESSING section of the AEPS. Fill out the form and click on SUBMIT. Using this form on the AEPS will enable us to respond quicker to your comments and better manage the DA Form 2028 program. You may also mail, fax or e-mail your letter, DA Form 2028 direct to: AMSTA-LC-CI/TECH PUBS, TACOM-RI, 1 Rock Island Arsenal, Rock Island, IL 61299-7630. The e-mail address is: TACOM-TECH-PUBS@ria.army.mil. The fax number is DSN 793-0726 or Commercial (309) 782-0726.

SUPERSEDURE NOTICE - This manual supersedes TM 5-3895-379-10, dated 27 March 2000.

DISTRIBUTION STATEMENT A - Approved for public release; distribution is unlimited.

Table of Contents

	Page Number
Warning Summary	a
How To Use This Manual	iii
CHAPTER 1 INTRODUCTORY INFORMATION WITH THEORY OF OPERATION	
WP 0001 00 General Information	0001 00-1
WP 0002 00 Equipment Description and Data	0002 00-1
WP 0003 00 Theory of Operation	0003 00-1
CHAPTER 2 OPERATING INSTRUCTIONS	
WP 0004 00 Description and Use of Operator's Controls and Indicators	0004 00-1
WP 0005 00 Operation Under Usual Conditions	0005 00-1
WP 0006 00 Operation Under Unusual Conditions	0006 00-1
WP 0007 00 Stowage and Decal, Data Plate, and Stencil Guide	0007 00-1

Table of Contents - Continued

	Page Number
CHAPTER 3 OPERATOR TROUBLESHOOTING	
WP 0008 00 Troubleshooting Instructions	0008 00-1
WP 0009 00 Troubleshooting Symptom Index	0009 00-1
WP 0010 00 Troubleshooting Procedures	0010 00-1
CHAPTER 4 OPERATOR MAINTENANCE INSTRUCTIONS	
WP 0011 00 Operator Preventive Maintenance Checks and Services (PMCS) Introduction	0011 00-1
WP 0012 00 Operator Preventive Maintenance Checks and Services (PMCS).	0012 00-1
WP 0013 00 General Maintenance Instructions.	0013 00-1
WP 0014 00 Engine Oil Level Check and Service.	0014 00-1
WP 0015 00 Fuel Level Check and Service.	0015 00-1
WP 0016 00 Fuel/Water Separator Service	0016 00-1
WP 0017 00 Engine Coolant Check and Service	0017 00-1
WP 0018 00 Hydraulic Oil Level Check and Service	0018 00-1
WP 0019 00 Draining and Filling Fuel and Hydraulic Oil Tanks	0019 00-1
WP 0020 00 Vibratory Bearing Reservoir Check and Service	0020 00-1
WP 0021 00 Front and Rear Propel Gearbox Oil Check and Service (CB534B)	0021 00-1
WP 0022 00 Adjust Handrails for Operation or Stowage	0022 00-1
WP 0023 00 Drum Scraper Service	0023 00-1
WP 0024 00 Water Spray System Check and Service	0024 00-1
WP 0025 00 Water Spray Nozzle Check and Service	0025 00-1
CHAPTER 5 SUPPORTING INFORMATION	
WP 0026 00 References	0026 00-1
WP 0027 00 Components of End Item (COEI) and Basic Issue Items (BII) Lists	0027 00-1
WP 0028 00 Additional Authorization List (AAL)	0028 00-1
WP 0029 00 Expendable and Durable Items List	0029 00-1

HOW TO USE THIS MANUAL

NOTE

If at any time you are unsure how to use this manual or you cannot locate the information you need, notify supervisor.

INTRODUCTION

1. This revised manual is designed to help you operate the CB534B and CB534C Roller, Motorized, Vibrating Tandem Steel Drums and perform operator troubleshooting and maintenance on the roller.
2. This manual is written in work package format:
 - a. Chapters divide the manual into major categories of information (e.g., *Introductory Information with Theory of Operation, Operating Instructions, Operator Troubleshooting, Operator Maintenance Instructions, and Supporting Information*).
 - b. Each Chapter is divided into work packages, which are identified by a 6-digit number (e.g. 0001 00, 0002 00, etc.) located on the upper right-hand corner of each page. The work package page number (e.g. 0001 00-1, 0001 00-2, etc.) is located centered at the bottom of each page.
 - c. If a Change Package is issued to this manual, added work packages use the 5th and 6th digits of their number to indicate new material. For instance, work packages inserted between WP 0001 00 and WP 0002 00 are numbered WP 0001 01, WP 0001 02, etc.
3. Scan through this manual to become familiar with its organization and contents before attempting to operate or maintain the roller.

CONTENTS OF THIS MANUAL

1. A *Warning Summary* is located at the beginning of this manual. Become familiar with these warnings before operating or performing operator troubleshooting or maintenance on the roller.
2. A *Table of Contents*, located in the front of the manual, lists all chapters and work packages in the publication.
 - a. The Table of Contents also provides *Reporting Errors and Recommending Improvements* information and DA Form 2028 addresses, for the submittal of corrections to this manual.
 - b. If you cannot find what you are looking for in the *Table of Contents*, refer to the alphabetical *Index* at the back of the manual.
3. Chapter 1, *Introductory Information with Theory of Operation* provides general information on the manual and the roller.
4. Chapter 2, *Operating Instructions* explains and illustrates all operator's controls and indicators and contains a *Stowage and Decal, Data Plate, and Stencil Guide*. It also describes how to perform all operating procedures for the roller: *Operation Under Usual Conditions* and *Operation Under Unusual Conditions*.
5. Chapter 3 covers all *Operator Troubleshooting*. WP 0009 00 contains a *Troubleshooting Symptom Index*. If the roller malfunctions, this index should always be consulted to locate the appropriate troubleshooting procedure.
6. Chapter 4 deals with *Operator Maintenance Instructions*. Major areas covered are *Preventive Maintenance Checks and Services (PMCS)* and operator level maintenance tasks.
7. Chapter 5 includes *Supporting Information: References, Components of End Item (COEI) and Basic Issue Items (BII) Lists, Additional Authorization List (AAL), and Expendable and Durable Items List*.

FEATURES OF THIS MANUAL

1. WARNINGS, CAUTIONS, NOTES, subject headings, and other important information are highlighted in **BOLD** print as a visual aid.

WARNING

A WARNING indicates a hazard which may result in injury or death.

CAUTION

A CAUTION is a reminder of safety practices or directs attention to usage practices that may result in damage to equipment.

NOTE

A NOTE is a statement containing information that will make the procedures easier to perform.

2. Statements and words of particular interest may be printed in CAPITAL LETTERS to create emphasis.
3. Within a procedural step, reference may be made to another work package in this manual or to another manual. These references indicate where you should look for more complete information. If you are told: "Start engine (WP 0005 00)", go to WP 0005 00 in this manual for instructions on starting engine.
4. Illustrations are placed after, and as close to, the procedural steps to which they apply. Callouts placed on the art are text or numbers.
5. Numbers located at lower right corner of art (e.g. 401-001; 401-002, etc.) are art control numbers and are used for tracking purposes only.
6. Technical instructions include metric units as well as standard units. For your reference, a *Metric Conversion Chart* is located on the inside back cover of the manual.

CHAPTER 1
INTRODUCTORY INFORMATION WITH
THEORY OF OPERATION

GENERAL INFORMATION

0001 00

SCOPE

1. **Type of Manual.** This manual is used for operating and performing operator troubleshooting and maintenance on the CB534B and CB534C Rollers, Motorized, Vibrating Tandem Steel Drums.
2. **Equipment Name and Model Number.** Roller, Motorized, Vibrating Tandem Steel Drums: Caterpillar Models CB534B and CB534C.
3. **Purpose of Equipment.** The CB534B and CB534C Rollers are self-propelled and designed to compact asphalt and gravel bases for parking lots, streets, roads, and highways.

MAINTENANCE FORMS, RECORDS, AND REPORTS

Department of the Army forms and procedures used for roller maintenance will be those prescribed by DA Pam 738-750, *Functional User's Manual for the Army Maintenance Management System (TAMMS)*, as contained in the Maintenance Management Update.

REPORTING EQUIPMENT IMPROVEMENT RECOMMENDATIONS (EIRs)

If your roller needs improvement, let us know. Send us an EIR. You, the user, are the only one who can tell us what you don't like about your roller. Let us know why you don't like the design or performance. Put it on an SF Form 368 (*Product Quality Deficiency Report*). Mail it to us at: Commander, U.S. Army Tank-automotive and Armaments Command, ATTN: AMSTA-AC-NML, Rock Island, Illinois 61299-7630. We'll send you a reply.

CORROSION PREVENTION AND CONTROL (CPC)

1. Corrosion Prevention and Control (CPC) of Army materiel is a continuing concern. It is important that any corrosion problems with this item be reported so that the problem can be corrected and improvements can be made to prevent the problem in future items.
2. While corrosion is typically associated with rusting of metals, it can also include deterioration of other materials, such as rubber and plastic. Unusual cracking, softening, swelling, or breaking of these materials may be a corrosion problem.
3. If a corrosion problem is identified, it can be reported using SF Form 368 (Product Quality Deficiency Report). Use of key words such as "corrosion," "rust," "deterioration," or "cracking" will ensure that the information is identified as a CPC problem. The form should be submitted to the address specified in DA Pam 738-750.

DESTRUCTION OF ARMY MATERIEL TO PREVENT ENEMY USE

For destruction of Army materiel to prevent enemy use, refer to TM 750-244-3.

WARRANTY INFORMATION

1. Caterpillar warrants the following products sold by it and operating within the area specified under "Limitations" to be free from defects in material and workmanship:
 - a. New earthmoving, construction materials handling, and paving product machines designated by Caterpillar as having a 6 month/unlimited hour warranty. See your Caterpillar dealer for a complete listing of covered models.
 - b. New engines used as replacements in such Caterpillar machines.
 - c. Attachments installed on such machines prior to delivery.
2. An additional warranty against breakage is applicable to certain Caterpillar Ground Engaging Tools. An additional warranty against wear is also applicable to certain weld-on landfill compactor plus tips. Refer to the appropriate warranty statement for coverage details. This warranty does not apply to Caterpillar brand batteries which are covered by a different Caterpillar warranty.

WARRANTY INFORMATION - CONTINUED

3. The warranty is subject to the following:
- a. **Warranty Period.**
 - (1) For the CB534B Roller, the warranty period is 6 months, starting from date of delivery to the first user.
 - (2) For the CB534C Roller, the warranty period is 12 months, starting from the date of delivery to the first user.
 - b. **Caterpillar Responsibilities.** If a defect in material or workmanship is found during the warranty period, Caterpillar will, during normal working hours and at a place of business of a Caterpillar or other authorized source:
 - (1) Provide (at Caterpillar's expense) new, Major Component Exchange (MCE), Remanufactured, or Caterpillar approved repaired parts or assembled components needed to correct the defect.

NOTE

Items replaced under this warranty become the property of Caterpillar.

- (2) Replace lubricating oil, filters, antifreeze and other service items made unusable by the defect.
 - (3) Provide labor needed to correct the defect except in the case of a new replacement engine originally installed by other than a Caterpillar dealer or other authorized source. In that case, labor is limited to repair only, and removal and installation is the user's responsibility.
- c. **User Responsibilities.** The user is responsible for:
- (1) The costs associated with transporting the roller.
 - (2) Labor costs, except as stated under "Caterpillar Responsibilities."
 - (3) Local taxes, if applicable.
 - (4) Parts shipping charges in excess of those which are usual and customary.
 - (5) Costs to investigate complaints unless the problem is caused by a defect in Caterpillar material or workmanship.
 - (6) Giving timely notice of a warrantable failure and promptly making the product available for repair.
 - (7) Performance of the required maintenance and use of proper fuel, oil, lubricants and coolant.
- d. **Limitations.** Caterpillar is not responsible for failures resulting from:
- (1) Any use or installation which Caterpillar judges improper.
 - (2) Attachments, accessory items and parts not sold by Caterpillar.
 - (3) Abuse, neglect and/or improper repair.
 - (4) User's unreasonable delay in making the product available after being notified of a potential product problem.

NEITHER THE FOREGOING EXPRESS WARRANTY NOR ANY OTHER WARRANTY BY CATERPILLAR, EXPRESS OR IMPLIED, IS APPLICABLE TO ANY ITEM CATERPILLAR SELLS WHICH IS WARRANTED TO THE USER BY ITS MANUFACTURER.

THIS WARRANTY IS EXPRESSLY IN LIEU OF ANY OTHER WARRANTIES, EXPRESS OR IMPLIED, INCLUDING ANY WARRANTY OF MERCHANTABILITY OR FITNESS FOR A PARTICULAR PURPOSE. REMEDIES UNDER THIS WARRANTY ARE LIMITED TO THE PROVISION OF MATERIAL AND SERVICES, AS SPECIFIED HEREIN. CATERPILLAR IS NOT RESPONSIBLE FOR INCIDENTAL OR CONSEQUENTIAL DAMAGES.

GENERAL INFORMATION - CONTINUED

0001 00

WARRANTY INFORMATION - CONTINUED

4. This warranty applies to all the geographic areas covered by the U.S.A. and Canadian dealers only. In other areas, different warranties may apply. Copies of applicable warranties may be obtained by writing Caterpillar Inc., 100 N.E. Adams Street, Peoria, IL 61829-3345.
5. As used in this warranty, the term "Caterpillar" means Caterpillar Inc., or one of its subsidiaries, except Caterpillar Overseas S.A., Caterpillar France S.A., Caterpillar (U.K.) Limited, or Caterpillar Belgium S.A., whichever last sold the product involved.

NOMENCLATURE CROSS-REFERENCE

COMMON NAME

OFFICIAL NOMENCLATURE

Roller.....Roller, Motorized, Vibrating Tandem Steel Drums
Caterpillar Model CB534B and Model CB534C

LIST OF ABBREVIATIONS

NOTE

Refer to ASME Y14.38-1999 for standard abbreviations.

ABBREVIATION

DEFINITION

AC.....	Alternating Current
AAL.....	Additional Authorization List
BII.....	Basic Issue Items
CW.....	clockwise
CCW.....	counterclockwise
daN.....	deka Newton
FPM.....	Feet Per Minute
hp.....	horsepower
in.....	inches
kg.....	kilograms
lb.....	pounds
KPH.....	Kilometers Per Hour
mm.....	millimeters
MPH.....	Miles Per Hour
pli.....	pounds per linear inch
ROPS.....	Rollover Protective Structure
rpm.....	revolutions per minute
RPSTL.....	Repair Parts and Special Tools Lists
Vac.....	Volts of alternating current
Vdc.....	Volts of direct current
VPM.....	Vibrations Per Minute

GLOSSARY

Amplitude.....	The amount of vibratory movement measured from the start of one stroke to the start of the next
Articulate.....	Move or shift at pivot point or joint
Compaction.....	The state of being pressed or packed together
Eccentric.....	Offset
Hydrostatic.....	Pressure exerted or transmitted by liquid at rest
Static.....	Without movement

END OF WORK PACKAGE

EQUIPMENT CHARACTERISTICS, CAPABILITIES AND FEATURES**NOTE**

Characteristics, capabilities and features are the same for the CB534B and CB534C Rollers, Motorized, Vibrating Tandem Steel Drums except as noted.

1. Characteristics.

- a. The roller is designed to be operated by one operator.
- b. The motion of the roller is controlled by the operator using a steering wheel and propel control lever (joystick).
- c. The roller is propelled by a hydrostatic transmission driven by a four-cylinder, turbocharged engine.
- d. Compaction is achieved with two cylindrical drums. Hydraulic motor-driven, eccentric weights produce vibration in the drums which enhances compaction.

2. Capabilities and Features.

- a. The roller has a static tip angle range of 40 to 50 degrees. The static tip angle is the slope angle where a stationary roller will begin to tip over to the side when it is parallel to the slope, in straight-ahead travel position.
 - (1) Roller operating stability depends upon many factors including operating speed, steering, braking, terrain conditions, fluid levels, and most of all operator's skill and judgement.
 - (2) The best operating roller stability indicator is the human operator with the ability to comprehend working conditions based on the relevant environmental situation and the operator's feel for the roller to predetermined situations potential hazards and determine the proper operating decisions to keep the roller in a safe operating mode.
- b. Vibration selection allows independent vibratory or static operation of either drum.
- c. Two amplitudes of vibration (high and low) are always available to the operator to accommodate the needs of a variety of operations.
- d. A water spray system wets the drum to help prevent hot asphalt from sticking to the drum surfaces during the compacting operation. Water spray can be constant or intermittent to accommodate the needs of a variety of environments. Two identical but separate tanks, each with their own pump and filter, are located on the front and rear of the roller and allow for extended operation between fill-ups. A tie line is provided allowing the operator to use one pump and tank to supply water to spray both drums in the event of failure of the other pump.
- e. 60/40 articulation simplifies maneuvering of the roller. 60% of the roller is behind the pivot, while 40% is ahead of the pivot. This allows the operator to concentrate on only one drum when entering or leaving a curve, and decrease risk of damage when moving roller away from curbs or other stationary objects.
- f. Operator station pivots 90 degrees in either direction to allow the operator to view drum surfaces and edges during back-and-forth rolling operation. The gauges and controls move with the operator station.
- g. The Roll Over Protective Structure (ROPS) canopy helps protect the operator from potential hazards resulting from equipment roll over and falling objects.

LOCATION AND DESCRIPTION OF MAJOR COMPONENTS

NOTE

Location and description of major components are the same for the CB534B and CB534C Rollers. CB534B Roller is shown.

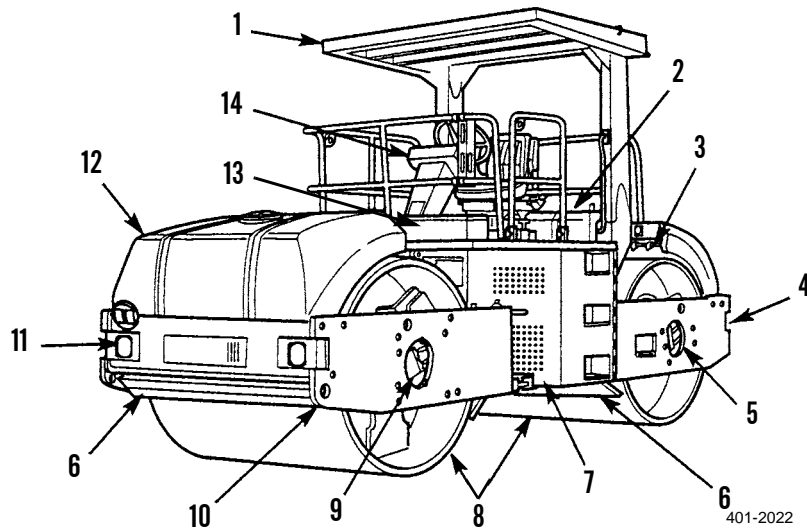

KEY	COMPONENT	DESCRIPTION
1	Rollover Protective Structure (ROPS)	The ROPS canopy helps protect the operator from potential hazards resulting from equipment roll over and falling objects.
2	Fuel/Hydraulic Oil Tank	The fuel and hydraulic tanks are connected, yet separate. Fuel is stored in the right side. The left side stores hydraulic oil.
3	Water Spray Bars	The water spray bars spray the drum surfaces with water to help prevent hot asphalt from sticking to the drums. There is a water spray bar located above front and rear drum.
4	Frame Assembly	The frame assembly provides a means of support for the roller components.
5	Vibratory Motors	The vibratory motors turn eccentric weights inside the drums which create vibrating force that aids in surface material compaction. They are located on the left side of the rear drum and the right side of the front drum.
6	Scrapers	The scrapers keep drums clean to provide a smooth compacted surface.
7	Engine Compartment	The engine and hydraulic pumps are located in this compartment. The engine and pumps power the steering, propel, and vibratory systems.

LOCATION AND DESCRIPTION OF MAJOR COMPONENTS - CONTINUED

KEY	COMPONENT	DESCRIPTION
8	Drums	The drums provide a smooth surface for surface material compaction.
9	Propel Motors	The propel motors provide power to the drums to move the roller. They are located on the right side of the rear drum and the left side of the front drum.
10	Yoke Assembly	The yoke assembly provides support for the front drum and pivots on the frame assembly for steering.
11	Work Lights	The work lights provide light for use in poor visibility situations. They are located at front and rear of roller.
12	Water Tanks	The water tanks hold water for delivery to the drums via the water spray nozzles on the spray bars. A water tank is mounted above each drum.
13	Toolbox	The toolbox holds the tools the operator needs to do all authorized maintenance.
14	Operator Station	The pivoting console may be moved 90 degrees to the left or right to increase visibility. The gauges and controls move with the console for easy operation.

DIFFERENCES BETWEEN MODELS

ITEM	CB534B	CB534C
Throttle	Mechanically controlled by cable	Electronic toggle switch (high/low)
Speedometer	No	Yes
Starting Aid	Water heater jacket	Air inlet heater
Handrails	Design differences; same function, different look	Design differences; same function, different look

EQUIPMENT DATA

General:

Type	Roller, Motorized, Vibrating Tandem Steel Drums
Model	Caterpillar, CB534B and CB534C Roller
Length (CB534B)	203 in. (5156 mm)
Length (CB534C)	195 in. (4953 mm)
Height	118 in. (2997 mm)
Width	73 in. (1854 mm)
Height at Steering Wheel	95 in. (2413 mm)
Operating Weight (CB534B)	21232 lb (9631 kg)

EQUIPMENT DESCRIPTION AND DATA - CONTINUED

0002 00

EQUIPMENT DATA - CONTINUED

General - Continued:

Operating Weight (CB534C)	21832 lb (9903 kg)
Static Tip Angle	40-50°

Functional:

Drum Width	67 in. (1700 mm)
Drum Diameter	51 in. (1300 mm)
Drum Shell Thickness	0.71 in. (18 mm)
Curb Clearance	16 in. (406 mm)
Side Clearance	3 in. (76 mm)
Wheelbase	124 in. (3150 mm)
Steering Angle -Left/Right	+/-35°
Minimum Turning Angle:	
Inside Drum Edge	164 in. (4166 mm)
Outside Drum Edge	231 in. (5867 mm)
Weight at Front Drum	10330 lb (4686 kg)
Weight at Rear Drum	11530 lb (5230 kg)

Refill Capacities:

Engine Oil	2.3 gal. (9 l)
Fuel Tank	55 gal. (208 l)
Hydraulic Tank (CB534B)	15.5 gal. (59 l)
Hydraulic Tank (CB534C)	24 gal (91 l)
Front and Rear Vibratory Bearing Reservoirs	3.1 gal. (12 l)
Water Tank	132 gal. (500 l) each
Cooling System	7.3 gal. (28 l)
Front Propel Gearbox	0.5 gal. (2 l)
Rear Propel Gearbox	0.6 gal. (2.4 l)

Power Train:

Engine	Caterpillar 3045T Turbocharged, Four-cylinder, diesel
Horsepower	107 hp (80 kw)@ 2200 rpm
Displacement	243 cu in. (4.0 l)
Transmission	Hydrostatic
Speed in Low Range	4.5 mph (7.2 kph)
Speed in High Range	7.0 mph (11.2 kph)

Vibratory System:

Electrical System	24 Volt
Frequency	2520 vpm (42 Hz)
Nominal Amplitude:	
Low	0.022 in. (0.56 mm)
High	0.043 in. (1.092 mm)
Centrifugal Force per Drum:	
Low	13480 lb (6000 daN)
High	26550 lb (11810 daN)

EQUIPMENT DESCRIPTION AND DATA - CONTINUED

0002 00

EQUIPMENT DATA - CONTINUED

Vibratory System - Continued:

PLI:

Static	161 lb/in. (28.8 kg/cm)
Centrifugal (max)	396 lb/in. (70.7 kg/cm)

Water Spray System:

Tank Material	Polyethylene
Number of Pumps	2
Number of Nozzles per Drum	7
Number of Drain Cocks	3
Number of Screens	2

END OF WORK PACKAGE

INTRODUCTION

1. This work package explains how components of the Roller, Motorized, Vibrating Tandem Steel Drums work together. A functional description is given for the electrical system, propel system, steering system, vibratory system and water spray system.
2. Theory of Operation is the same for the CB534B and CB534C Rollers. CB534B Roller is shown.

BASIC OPERATION

1. The roller is designed to compact asphalt and gravel bases for constructing parking lots, roads, landing strips, and other asphalt-paved areas.
2. The roller is controlled by a single operator.
3. The roller operates in vibratory mode, using twin vibrating drums, as the means for compacting surface material.
4. The roller operates in static mode in order to smooth surface material.
5. An on-board water spray system is provided to prevent hot asphalt from sticking to the drum surfaces.

ELECTRICAL SYSTEM

1. The electrical system operates on 24 volts, negative ground. It is powered by two 12-volt batteries connected in series to produce 24 volts. The electricity stored in the batteries is used to start the engine and separate accessories. When started, the engine drives an alternator that produces electricity to both maintain battery voltage and power electrical components on the roller.
2. The engine start switch has three positions (OFF, ON, and START). In the OFF position, no circuits have access to the batteries' power. In the ON position, all circuits are fully powered. In the START position, electricity is directed from the batteries through a relay and a solenoid to the starter.
3. A standard NATO connector is connected to the batteries to allow the operator to "jump start" the roller from another roller when the roller batteries are low. A battery disconnect switch is provided to isolate the battery from the electrical system when the roller is not in use.
4. With the engine running and the engine start switch in the ON position, the alternator produces between 24 and 28 volts of electricity for charging the batteries and operating accessories. The system is protected against overload by fuses and circuit breakers.

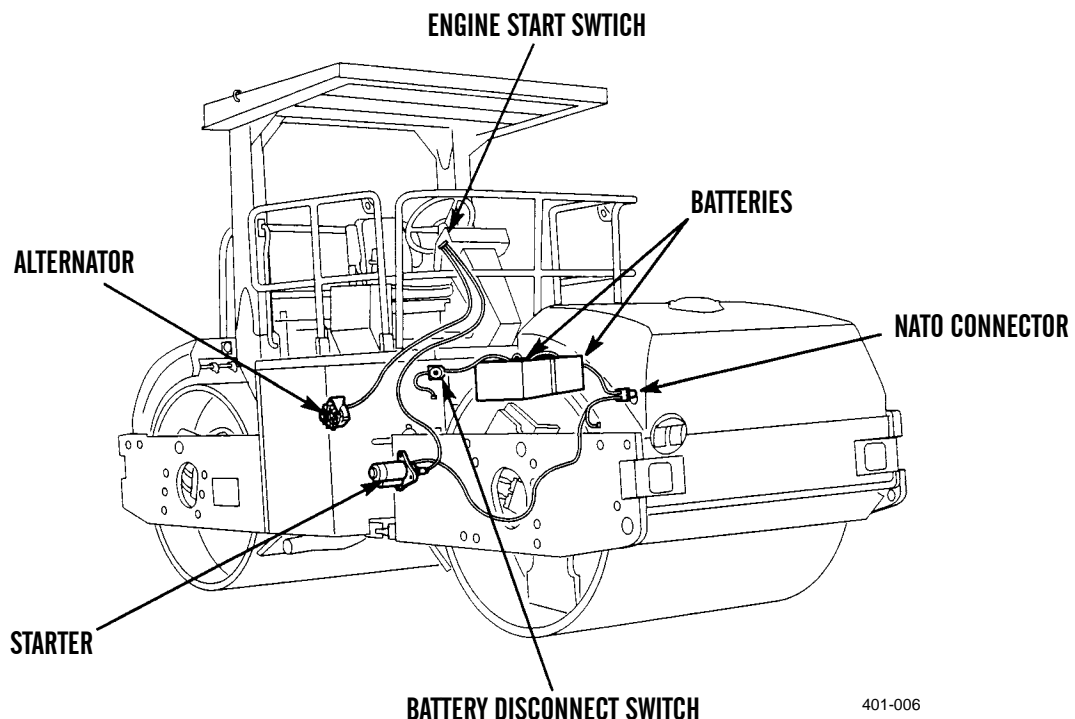

401-006

PROPEL SYSTEM

1. The propel control lever, when pushed forward, causes the roller to go forward. Pull the propel control lever backward to go in reverse. The propel control lever controls the flow of pressurized hydraulic oil to the propel motors. The hydraulic propel motors, located on the left of the front drum and the right of the rear drum, turn the propel gearboxes which turn the roller drums. The propel speed switch is a toggle switch that controls whether the propel system operates in high-speed range (hare) or low-speed range (tortoise) by activating the shift solenoid to change the flow rate of hydraulic oil to the propel gearboxes.
2. Inside each propel gearbox is a brake which is automatically engaged when there is no hydraulic pressure resulting from the activation of the propel system in forward or reverse. When the roller needs to be moved while the engine is not running, a manual brake release pump can be used to release the brakes. Brake and neutral start relays in the system prevent movement of the roller during the starting procedure.
3. The power for the propel system comes from a four-cylinder, turbocharged diesel engine mounted in the center of the roller. The engine is attached to the propel hydraulic pump, which provides the pressure charge for the propel system.
4. The fuel/hydraulic oil tank consists of the hydraulic tank (located on the left side) and the fuel tank (located on the right side). Although the tanks are welded together, they are separate in their function. The CB534B Roller hydraulic oil tank holds 15.5 gallons (59 liters) of hydraulic oil. The CB534C Roller hydraulic tank holds 24 gallons (91 liters) of hydraulic oil. The fuel tank holds 55 gallons (208 liters) of diesel or JP-8 fuel to supply the engine.

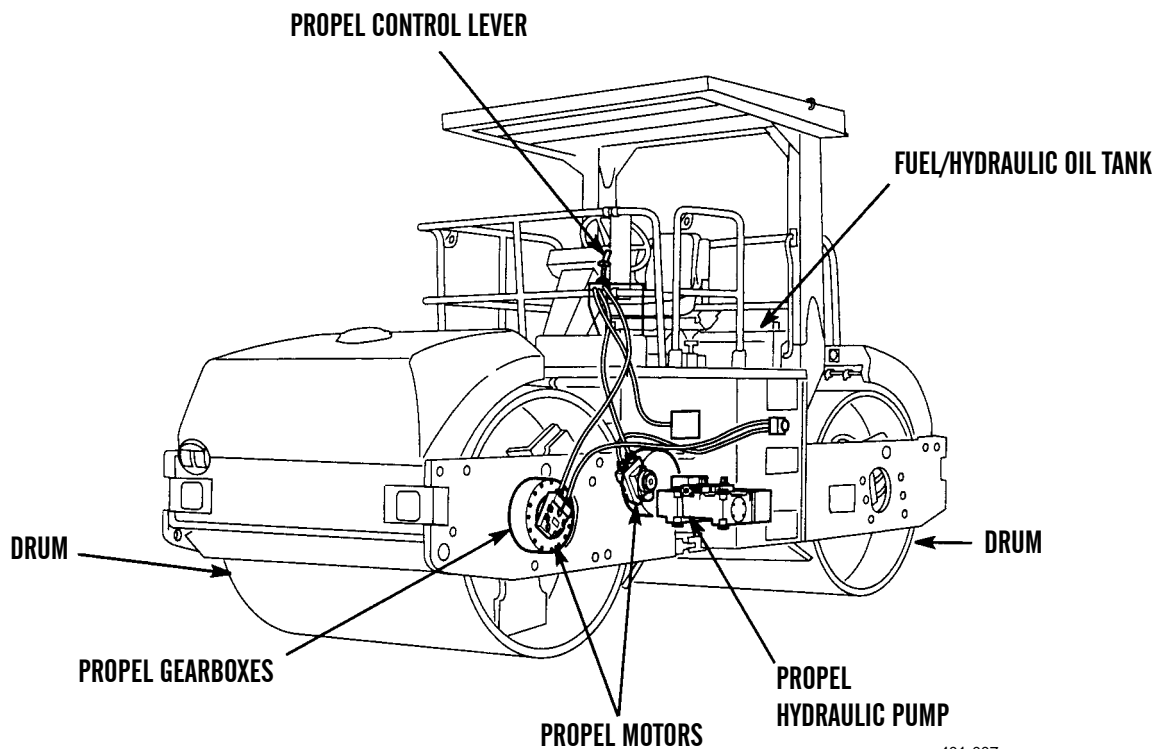

STEERING SYSTEM

1. The steering system is based on a 60/40 articulation. 40% of the roller is located in front of the articulation pivot point. 60% is located in the rear. The front drum is attached to the yoke assembly, while the rear drum is attached to the frame assembly. Two hydraulic steering cylinders provide the motive force to steer the roller by articulating (shifting the yoke and frame of) the roller to change the path of travel. The steering wheel controls the direction of travel by actuating a hydraulic steering control valve which directs pressurized hydraulic oil to the hydraulic steering cylinders.
2. The steering system's hydraulic steering pump has two functions. The primary purpose is providing pressurized hydraulic oil used in steering the roller. Secondly, the steering system hydraulic pump is used to charge the propel system.

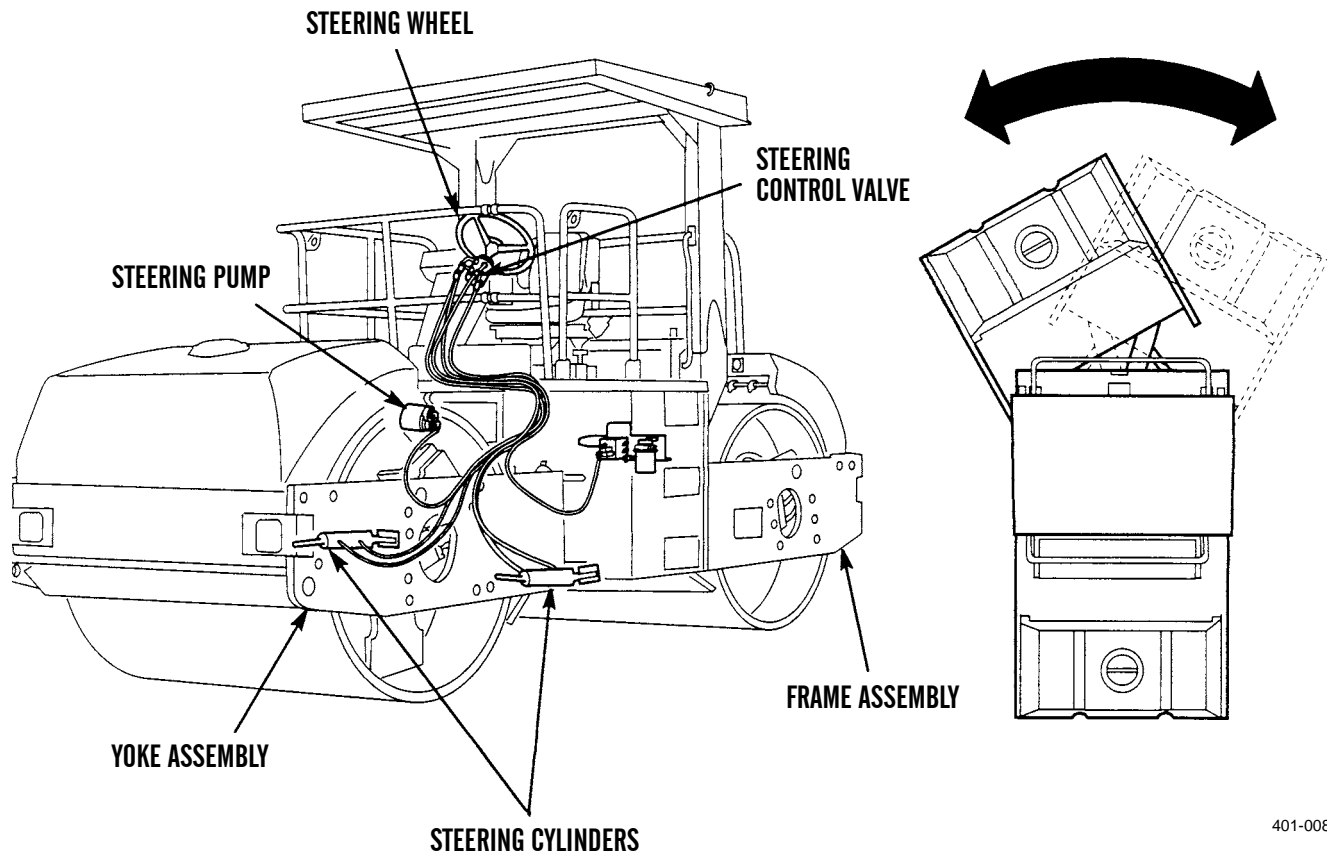

401-008

VIBRATORY SYSTEM

1. The hydraulic vibratory motors, located on the left of the front drum and the right of the rear drum, turn an eccentric weight located inside each drum. As the eccentric weight spins, kinetic energy creates forces that cause the drum to vibrate, which intensifies the roller compaction of surface material. The eccentric weight is a chamber filled with steel shot and has a weight attached to one side. Inside the chamber are baffles. As the weight is turned one direction, the baffle collects the steel shot on the same side as the weight to produce a severe imbalance in the rotation. The imbalance causes the entire drum to vibrate. This is the high amplitude. As the weight is turned the other direction, the baffle collects the steel shot on the opposite side as the weight to produce a mild imbalance in the rotation causing less vibration. This is the low amplitude.
2. Each drum is isolated from the rest of the roller by twenty-four rubber isolation blocks. The isolation blocks allow the operator to remain in relative comfort as the drums are fully vibrating. The vibratory system gets its power from the vibratory hydraulic pump, which is attached to the propel hydraulic pump which is attached to the engine.
3. The vibration control switches control the varied vibratory modes by activating electric solenoids in the hydraulics of the vibratory system. The operator can select which drum vibrates, how the system is activated, and the severity of the vibration action.

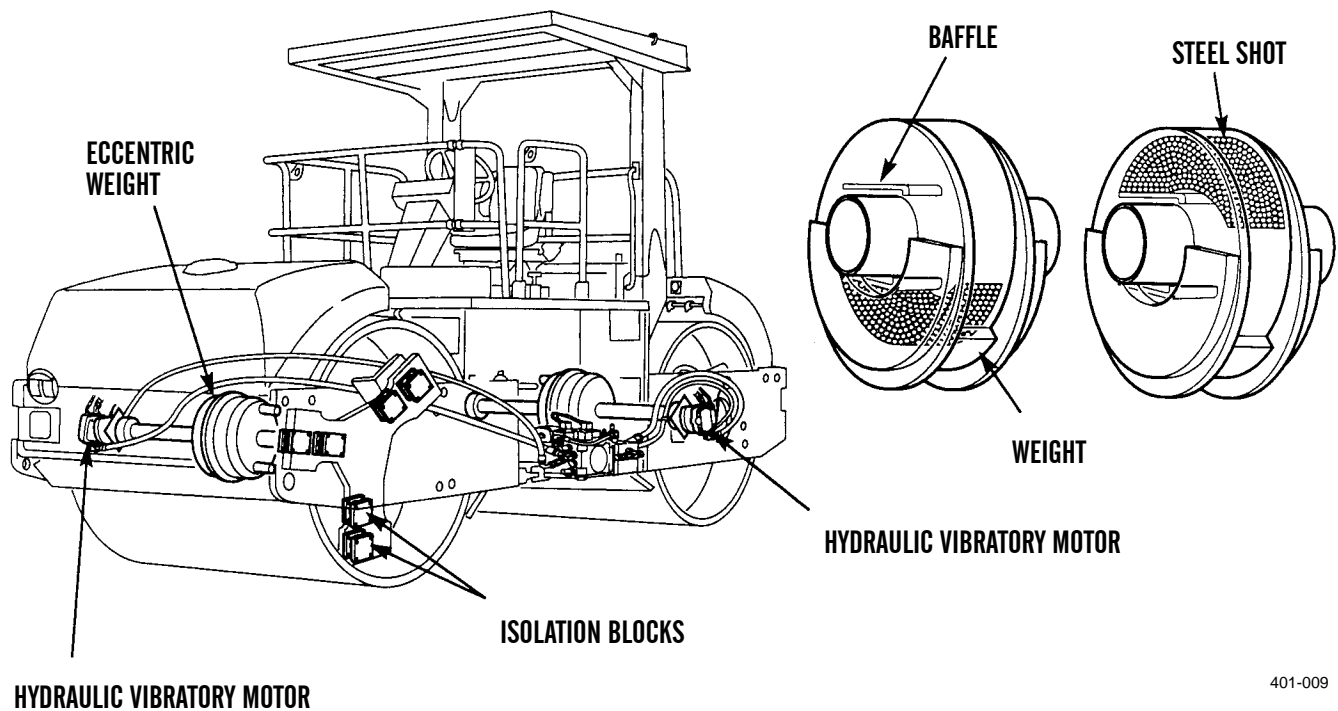

401-009

WATER SPRAY SYSTEM

1. The water spray system is used to wet the front and rear drums to help prevent hot asphalt from sticking to the drum surfaces during compaction. The water spray system consists of two identical, but separate systems, one at each end of the roller.
2. The water spray system uses pumps controlled by a switch on the operator's console to provide water flow. The switch has three positions: off, continuous spray, and intermittent spray. The continuous spray setting turns on the water spray system and water sprays on the drums continuously. The intermittent spray switch position uses 15-second cycles of water spraying on the drums and no water spraying on the drums to reduce water consumption.
3. There are three drain cocks that allow the water to be drained from the system. The pumps pull water from two tanks and water spray screens which filter foreign materials from the water. The water then enters the pump and is pumped to the spray bar. There are seven spray nozzles in each spray bar which distribute the water evenly over the surface of the drums. A check valve is located at the end of the spray bar to control the pressure of the water in the spray bars. Excess water is sent past the check valve and back into the water tank. On the CB534B only, the front and rear water spray systems are connected by a tie-line valve, which allows one water spray system to supply pressurized water to the nozzles of the other water spray system, in the event of failure of one of the pumps.

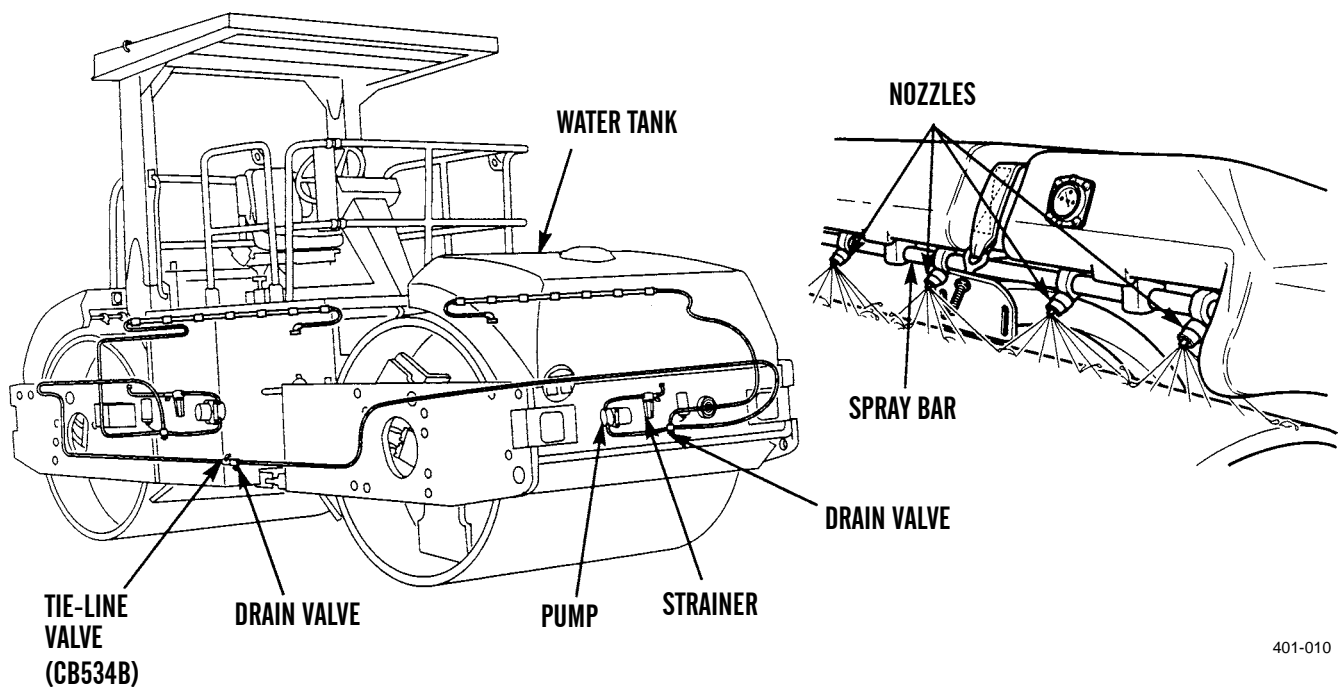

END OF WORK PACKAGE

CHAPTER 2
OPERATING INSTRUCTIONS

DESCRIPTION AND USE OF OPERATOR'S CONTROLS AND INDICATORS

0004 00

GENERAL

1. Before operating the CB534B or CB534C Roller, Motorized, Vibrating Tandem Steel Drums, read and become familiar with the location and function of all operator controls and indicators, as described in this work package.
2. CB534B Roller is shown unless otherwise indicated.

CONTROLS AND INDICATORS

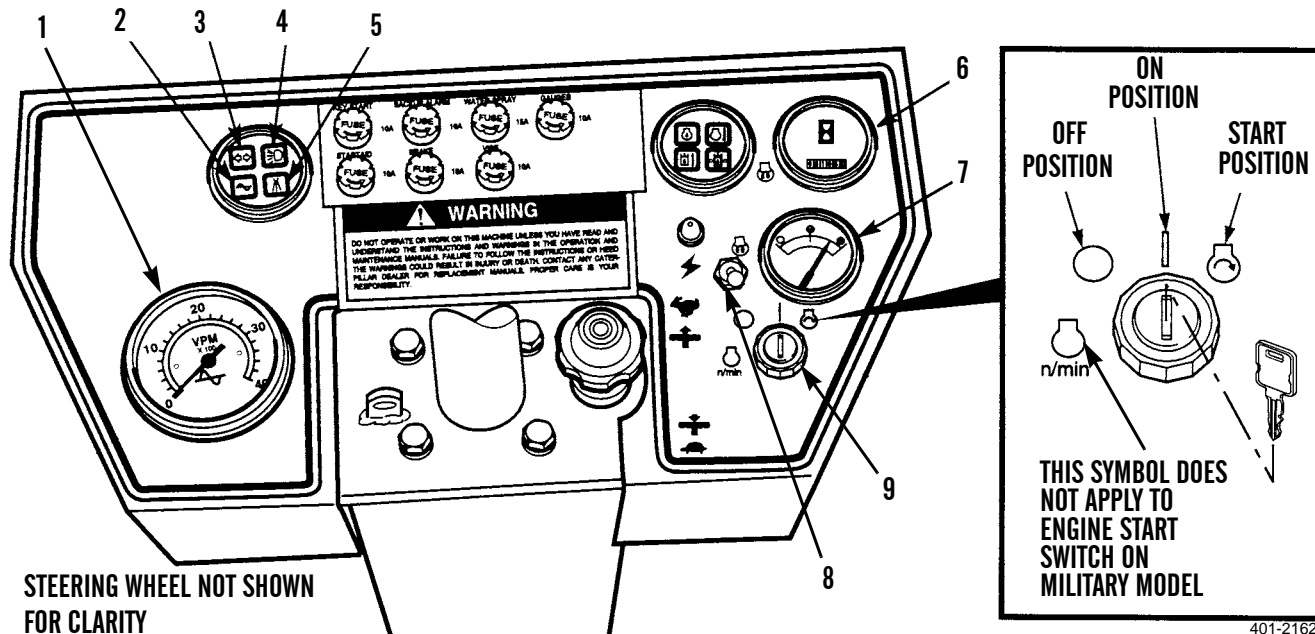

STEERING WHEEL NOT SHOWN FOR CLARITY

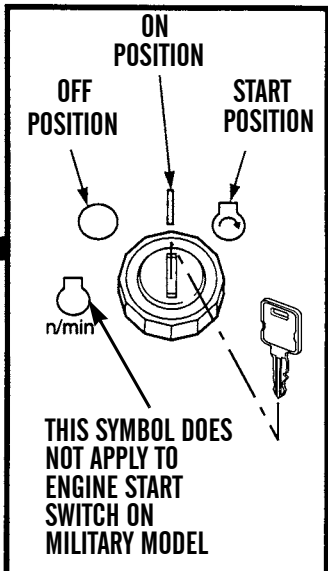

401-2162

KEY	CONTROL OR INDICATOR	FUNCTION
1	Vibration Per Minute (VPM) Tachometer	Indicates vibrations per minute (frequency of drum vibration). Gauge reading indicates the VPM of weight shafts of drum(s) selected by the position of the vibratory mode control switch.
2	Vibratory System Indicator	When illuminated, indicates the vibration push switch is in the ON position.
3	Turn Signal Indicator	Not used.
4	Lights Indicator	When illuminated, indicates the lights are on.
5	Water Spray System Indicator	When illuminated, indicates the water spray system is activated.
6	Service Hourmeter	Displays the total number of hours the engine has been operated.
7	Fuel Level Gauge	Indicates the amount of diesel fuel or JP-8 in the fuel tank.
8	Starting Aid Switch	On the CB534B, the starting aid switch powers the cold start heater which warms a small amount of fuel that enters the combustion chamber. The heater is used in cold weather to help start the engine. On the CB534C, the switch powers the air inlet heater which warms the air that enters the engine.
9	Engine Start Switch	Ignition key controls the mode of engine and electrical system. The START (full right) position is used to crank the engine for starting. The ON (right) position is used to activate all electrical circuits and allows the engine to run once it is started. The OFF (left) position stops the engine and shuts down all electrical circuits.

CONTROLS AND INDICATORS - CONTINUED

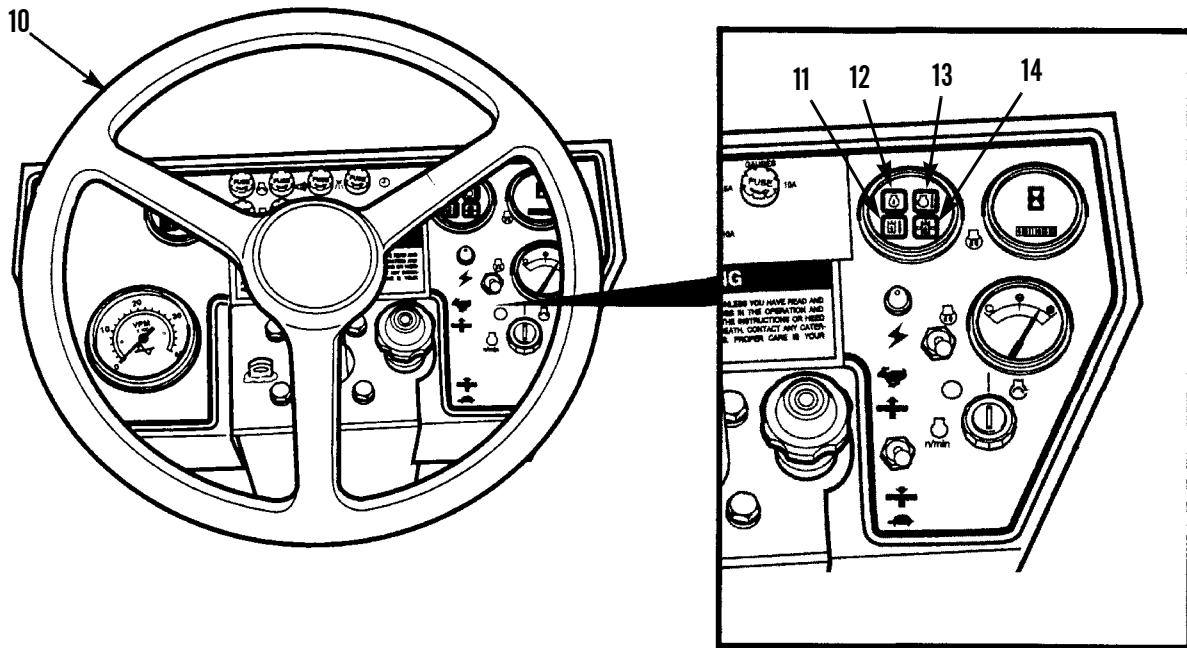

401-2171A

KEY	CONTROL OR INDICATOR	FUNCTION
10	Steering Wheel	Controls roller direction of travel.
11	Hydraulic Oil Temperature Warning Light	Illuminates to warn operator of overheating of the hydraulic oil in the system. If the indicator does not go out shortly after the engine is started or if the indicator comes on while the engine is running, operator should stop engine and notify supervisor.
12	Engine Oil Pressure Warning Light	Illuminates to warn operator of low engine oil pressure or a system malfunction. If the indicator does not go out shortly after the engine is started or if the indicator comes on while the engine is running, operator should stop engine and notify supervisor.
13	Engine Coolant Temperature Warning Light	Illuminates to warn operator of overheating of the engine coolant or a system malfunction. If the indicator does not go out shortly after the engine is started or if the indicator comes on while the engine is running, operator should stop engine and notify supervisor.
14	Hydraulic Oil Pressure Warning Light	Illuminates to warn operator of a malfunction causing low hydraulic system pressure. If the indicator does not go out shortly after the engine is started or if the indicator comes on while the engine is running, operator should stop engine and notify supervisor.

CONTROLS AND INDICATORS - CONTINUED

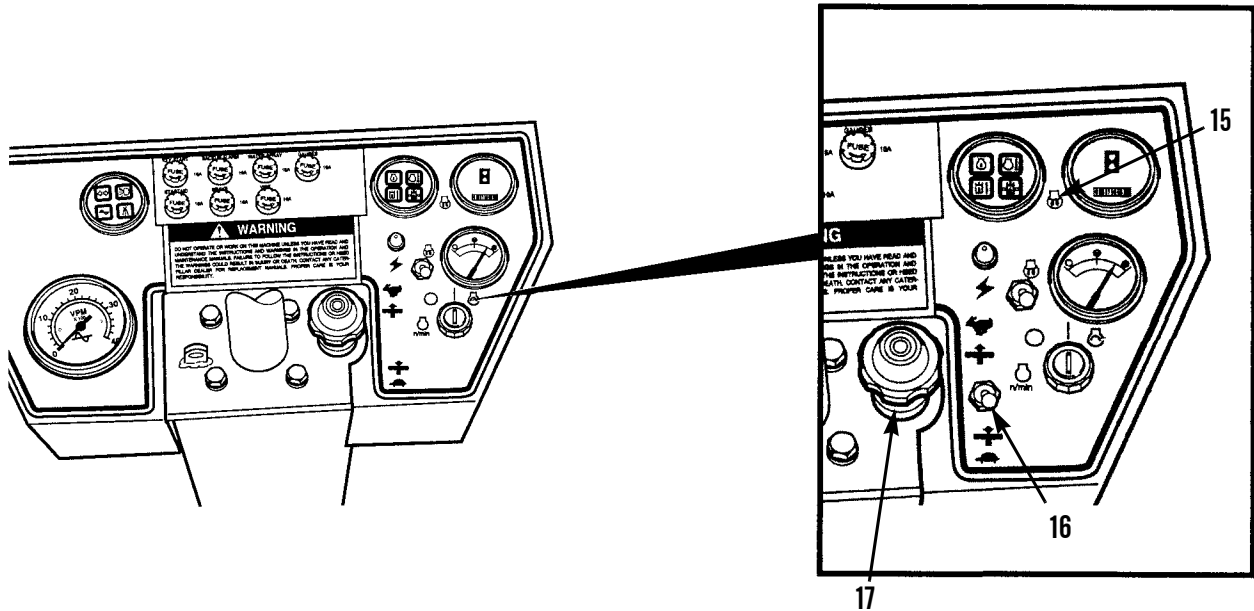

401-2171

KEY	CONTROL OR INDICATOR	FUNCTION
15	Alternator Indicator	Illuminates to warn the operator of an alternator malfunction. If the indicator does not go out in 15 seconds after the engine is started or if the indicator comes on while the engine is running, operator should shut down roller and investigate cause.
16	Throttle Control Switch (CB534C Only)	A two-position switch used to control the engine speed. Select low (tortoise) for low engine idle speed or high (hare) for high engine idle speed.
17	Throttle Control	Controls the engine Revolutions Per Minute (RPM). Push and hold button to allow push/pull movement of throttle control. Push throttle control down to reduce engine speed. Pull throttle control up to increase engine rpm. Release button at the desired throttle position. Turn throttle lock full right to lock the throttle control at a desired engine rpm. Turn the throttle lock full left to release the throttle control to change engine rpm.

CONTROLS AND INDICATORS - CONTINUED

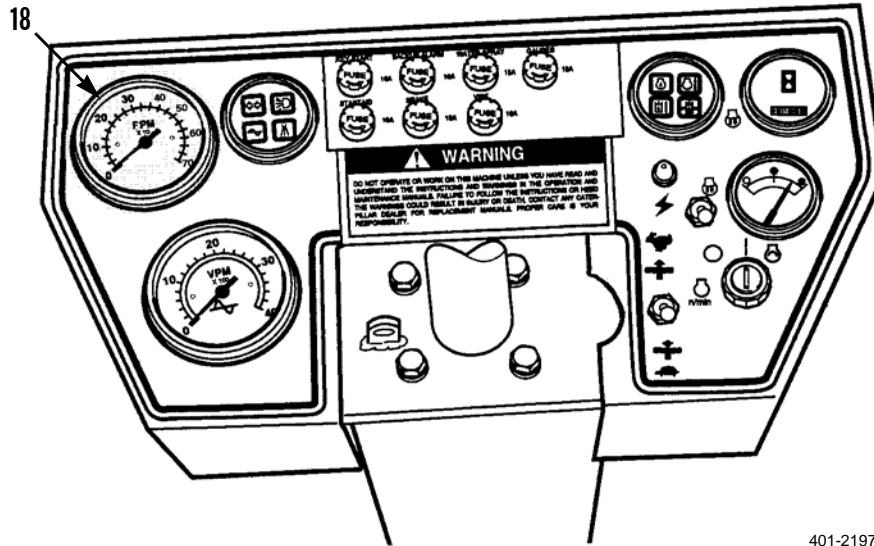

401-2197

KEY	CONTROL OR INDICATOR	FUNCTION
18	Speedometer (CB534C Only)	Indicates roller's ground speed in FPM (Feet Per Minute) x 10 and km/h.

CONTROLS AND INDICATORS - CONTINUED

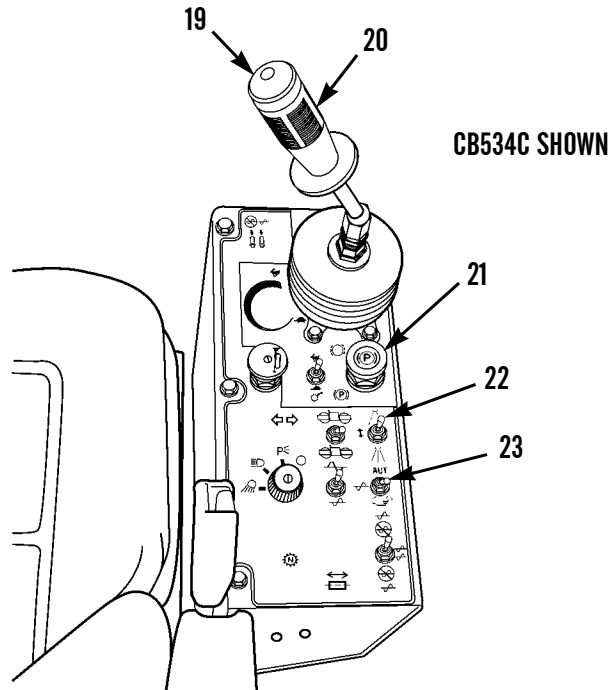

401-2164

KEY	CONTROL OR INDICATOR	FUNCTION
19	Vibration Push Switch	Turns the vibratory system on by pressing once or off by pressing again.
20	Propel Control Lever	Controls the direction and speed of travel for the roller. Push forward to go forward. Pull all the way back to go in reverse. Brakes are activated when in the NEUTRAL (middle) position. Backup alarm sounds when in reverse.
21	Parking Brake Switch	Applies the parking brake when pressed. Releases the parking brake when pulled up.
22	Water Spray Switch	Turns the water spray system to off (center position), continuous (pull back) or intermittent (push forward) modes.
23	Vibration Control Switch	Turns the vibratory system to manual (MAN) or automatic (AUTO) modes.

CONTROLS AND INDICATORS - CONTINUED

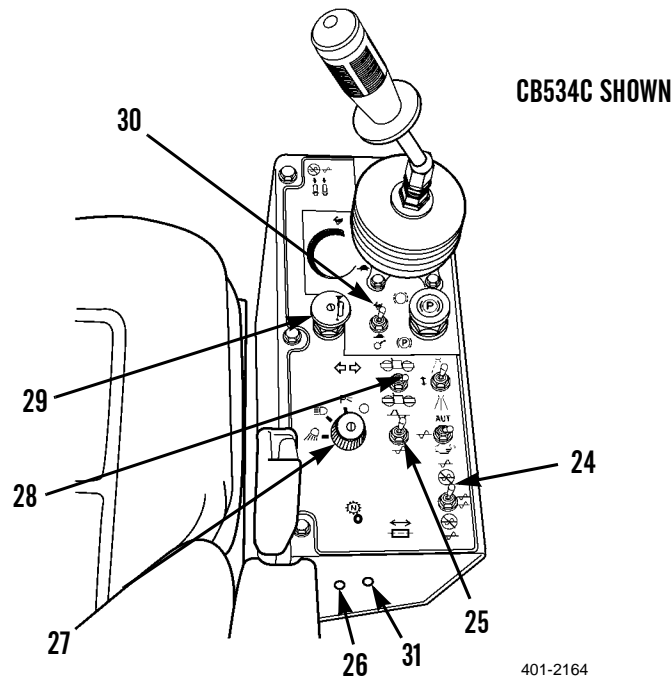

KEY	CONTROL OR INDICATOR	FUNCTION
24	Drum Select Switch	Activates the vibratory systems in the front (push forward), rear (pull back) or both drums (center position).
25	Amplitude Select Switch	Turns the amplitude of vibration to high (push forward) and low (pull back) pitches.
26	Lights Circuit Breaker Reset Button	Push to reset lighting circuit to provide power to lights. Circuit breaker will trip in the event of electrical system malfunction.
27	Lights Switch	Rotate the 4-position switch to control the work light. Beginning from the full right rotation position, one is OFF. Second position turns instrument panel lights ON. Third position turns front work lights only ON. Fourth position turns front and rear work lights ON.
28	Water Tank Selector Switch (CB534C Only)	Controls the use of water from the front or rear water tank. For front water tank, move switch forward. For the rear water tank, move switch rearward.
29	Horn Switch	Press to sound horn.
30	Propel Speed Range Switch	Allows the roller to operate in either low (tortoise) or high (hare) propel speed modes.
31	Throttle Control Circuit Breaker Reset Button	Push to reset throttle control circuit to provide power to throttle control. Circuit breaker will trip in the event of electrical system malfunction.

CONTROLS AND INDICATORS - CONTINUED

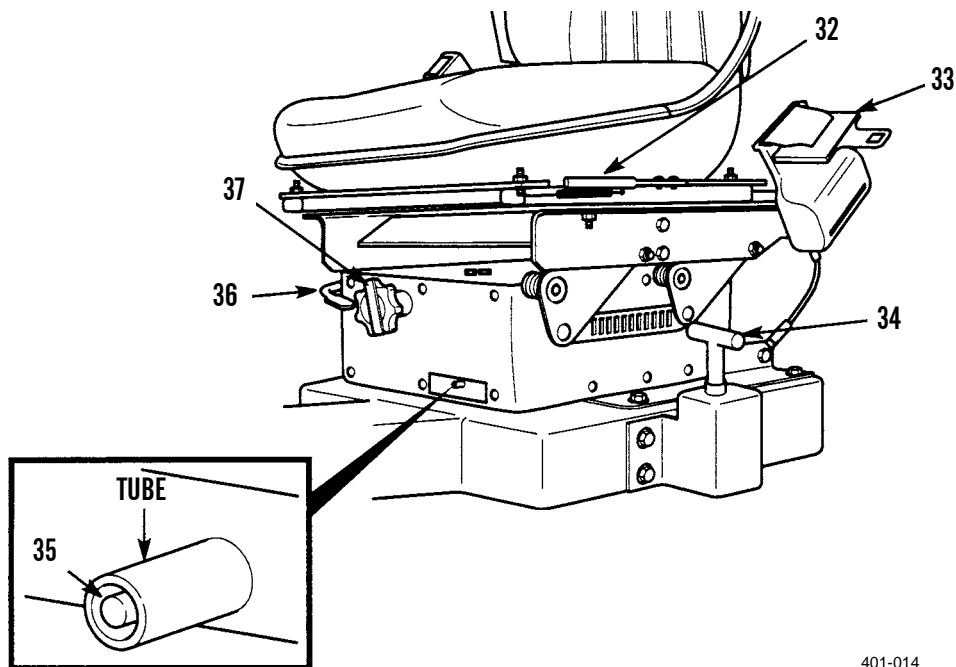

401-014

KEY	CONTROL OR INDICATOR	FUNCTION
32	Fore-aft Lever	Adjusts seat forward or backward when pulled to left.
33	Seat Belt	Provides for operator safety during operation of roller. Seat belts must be worn each time the roller is moved.
34	Rotation Lock	Lever locks operator station in five positions on operator platform. Holes in operator platform are located to position operator station direct forward and 45 degrees and 90 degrees in either direction. Pull up on lever to release pin to allow platform rotation.
35	Ride Adjustment Indicator	Ride adjustment is correct when the rod is aligned with the tube.
36	Lift Lever	Adjusts seat height when pressed down. Release of lever locks seat height into position.
37	Ride Adjustment Knob	Adjusts firmness of ride. Tighten for firmer ride, loosen for less firm ride.

CONTROLS AND INDICATORS - CONTINUED

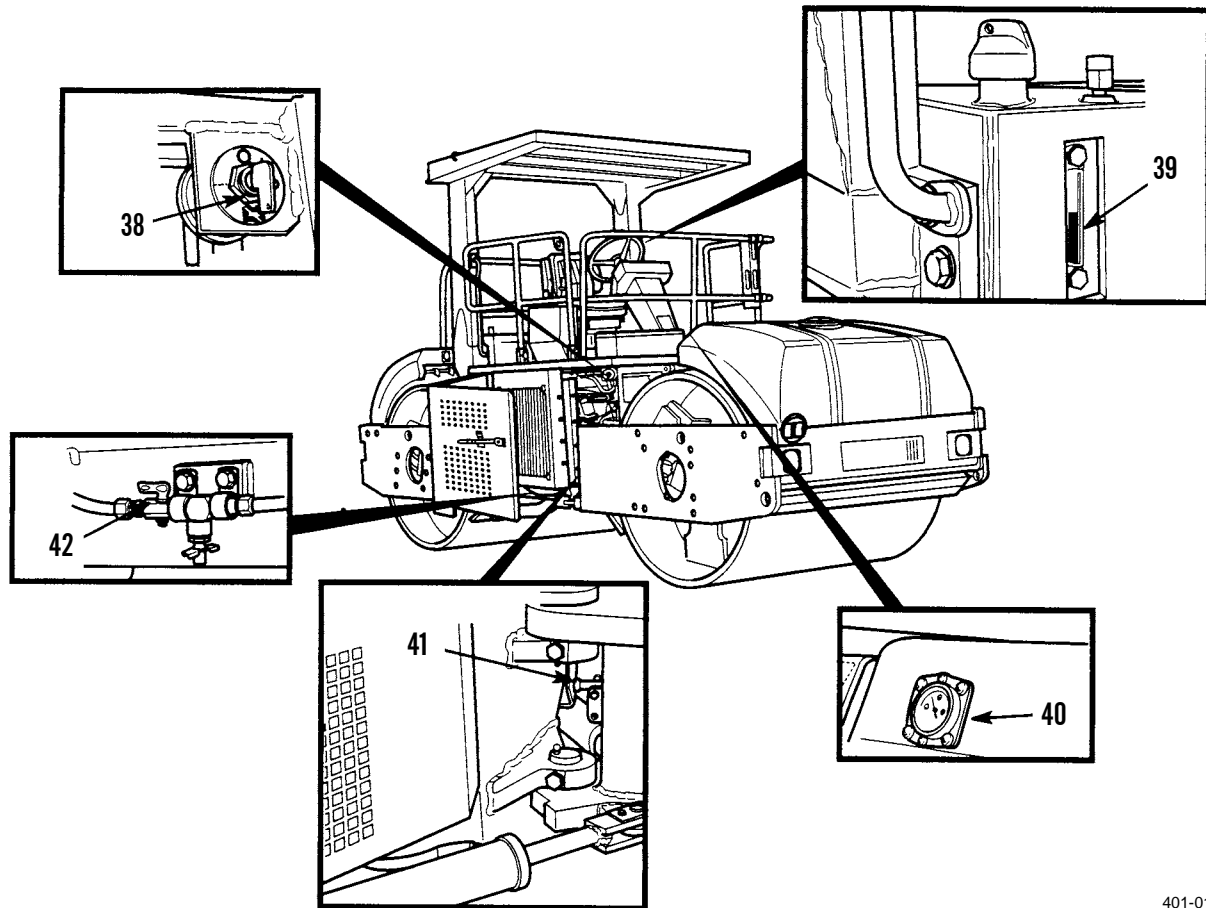

401-015

KEY	CONTROL OR INDICATOR	FUNCTION
38	Battery Disconnect Switch and Key	Disconnects negative battery cable-to-ground connection by turning battery disconnect key counterclockwise while roller is not in operation. Insert and turn key clockwise to connect battery cable-to-ground connection.
39	Fuel/Hydraulic Oil Tank Sight Gauge	Measures level of hydraulic oil in fuel/hydraulic oil tank. Level can be observed in glass tube. FULL COLD and ADD levels are indicated on gauge.
40	Water Level Gauge	Measures water level in water spray system tanks. Needle on gauge indicates level. Full left is empty, full right is full. There is a water level gauge located on both tanks.
41	Steering Frame Lock	Locks steering system in place for shipping needs by moving position of pin up to lock and down to steer.
42	Tie-Line Valve (CB534B)	Connects front and rear water spray systems. One system can be used to pump water for both if other system pump fails. Turning the valve handle 90 degrees away from water lines isolates front and rear water spray systems.

CONTROLS AND INDICATORS - CONTINUED

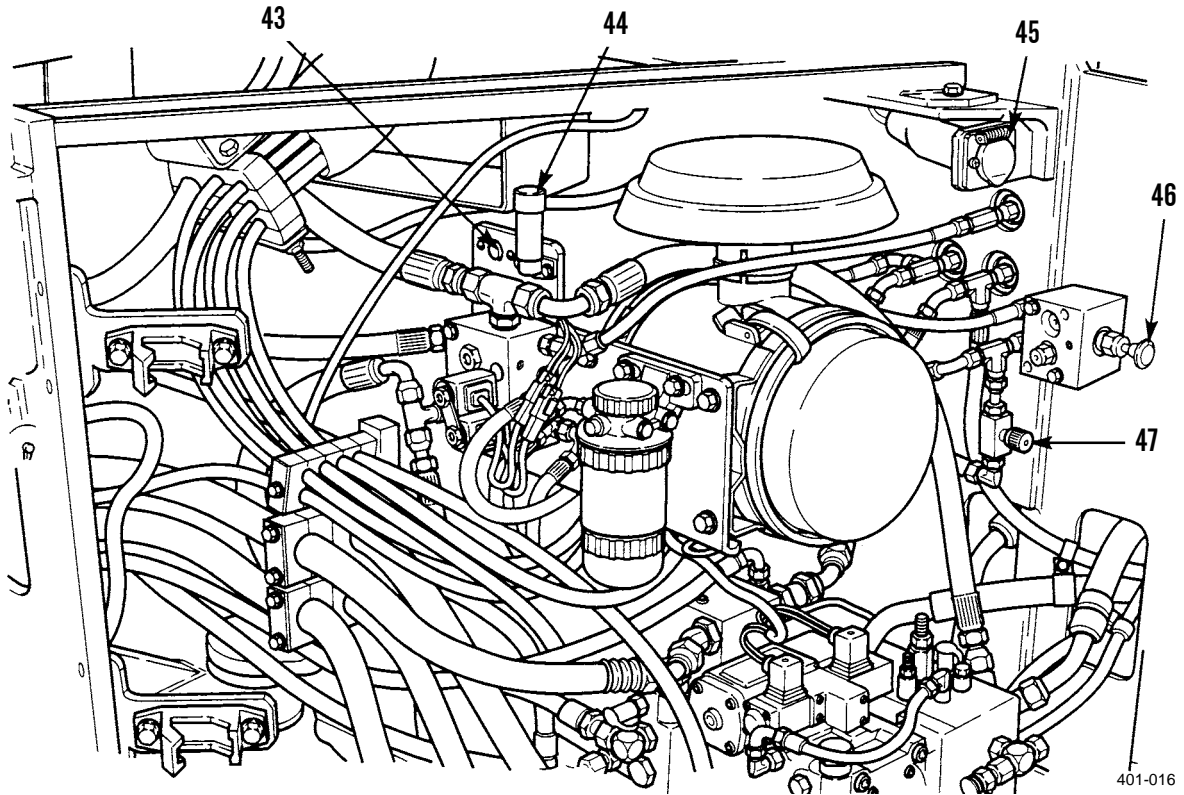

KEY	CONTROL OR INDICATOR	FUNCTION
43	Alternator Circuit Breaker Reset Button	Push to reconnect alternator circuit to provide power to roller. Circuit breaker will trip in the event of electrical system overload.
44	Air Filter Service Indicator	Indicates condition of air filter. Air filter requires service when red appears in viewing window or when the arrow is at the 22 in. position. Push reset button on top of service indicator after filter service is complete.
45	Engine Heater Connector	Attach a cable (extension cord) with 120Vac to this connection to warm engine coolant overnight during cold weather.
46	Manual Brake Release Valve	Pressing knob manually pumps hydraulic oil to release brakes. This action can be used for short distance moving of roller when engine is off or unable to be started.
47	Manual Brake Release Needle Valve	Locked open for normal operation. Unlock setscrew and close valve to use manual brake release pump.

CONTROLS AND INDICATORS - CONTINUED

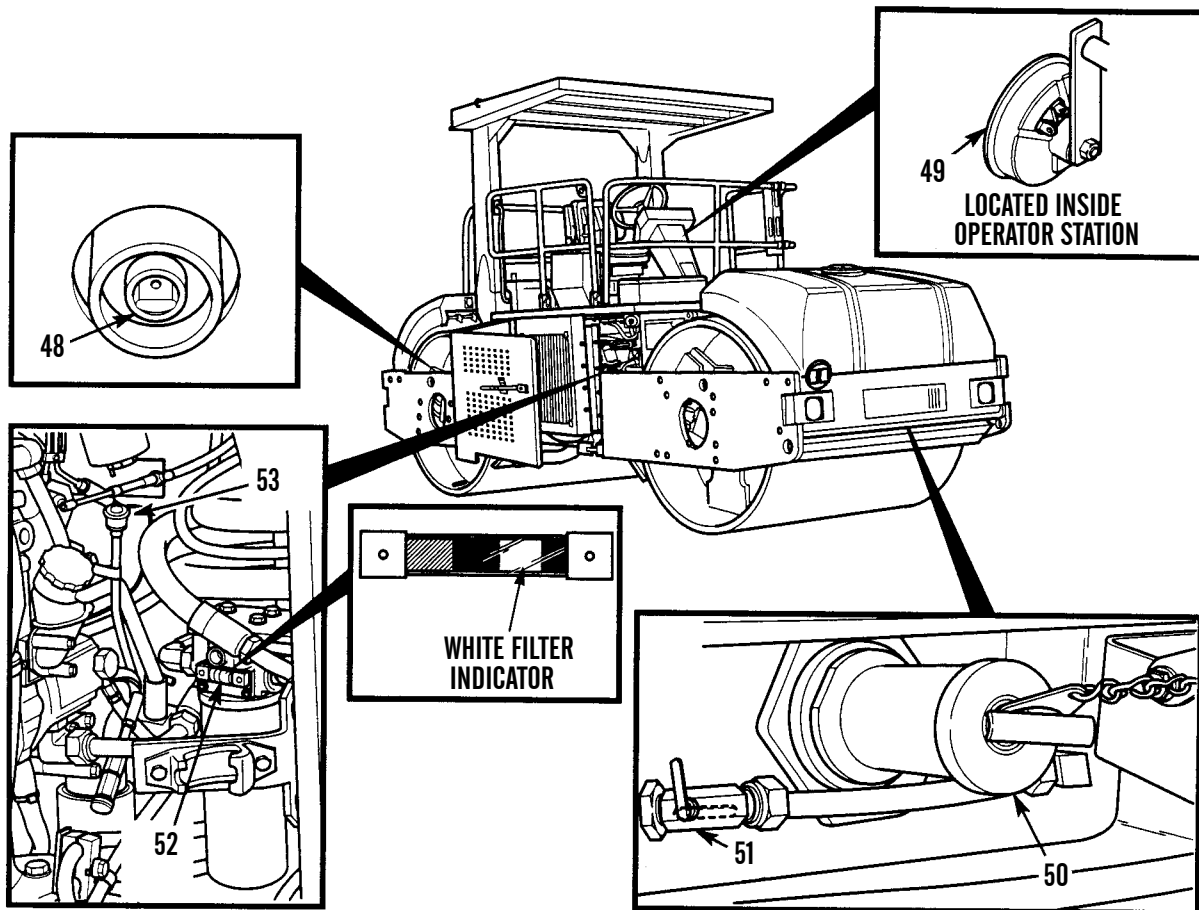

401-017

KEY	CONTROL OR INDICATOR	FUNCTION
48	Vibratory Bearing Oil Level Gauge	Vibratory bearing oil level for front and rear vibratory bearing reservoirs can be checked with this sight gauge when drum is positioned with welded rod at bottom of the drum.
49	Warning Horn	Sounds alarm during same time warning lights are illuminated.
50	Water Tank Drain Plug	Turn the tee handle and remove the drain plug to drain water from the water tank. A drain plug is located on each of the water tanks.
51	Water Tank Shut-off Valve	Closes or opens the flow of water from the water tank to the water spray screen during screen cleaning.
52	Hydraulic Oil Filter Indicator	Indicates amount of contamination collected inside hydraulic oil filter. When white indicator reaches the red zone, filter needs to be replaced.
53	Engine Oil Gauge Rod (Dipstick)	Indicates level of oil in crankcase of engine. Two marks are provided to indicate acceptable high and low levels. When the oil is below the low level, add oil to the engine.

END OF WORK PACKAGE

GENERAL

1. This work package contains instructions for safely operating the CB534B and CB534C Rollers, Motorized, Vibrating Tandem Steel Drums under usual conditions. Unusual conditions are defined and described in WP 0006 00.
2. Refer to WP 0004 00 for the location and function of all controls and indicators required for roller operation.
3. CB534B Roller is shown unless otherwise indicated.

INITIAL ADJUSTMENTS AND DAILY CHECKS



WARNING

- Operators must wear protective head gear. Failure of operators to wear protective head gear may result in serious injury or death.
- Unlock steering frame before operation to prevent loss of steering that may cause injury or death.

1. **Unlock Steering Frame.**

- a. Remove clip (1) and pin (2) from articulation yoke (3).
- b. Lift and hold steering frame lock bolt (4) to top of slot in articulation yoke (3).
- c. Install pin (2) in top hole in articulation yoke (3), ensuring steering frame lock bolt (4) is above pin (2).
- d. Release steering frame lock bolt (4) and install clip (1) in pin (2).

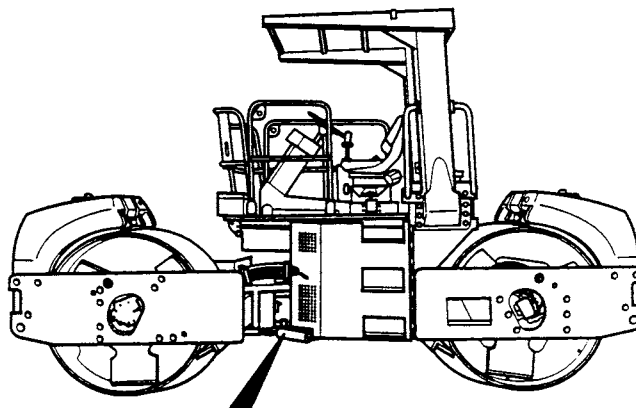

2. **Lock Steering Frame.**

- a. Remove clip (1) and pin (2) from articulation yoke (3).
- b. Position steering frame lock bolt (4) to bottom of slot in articulation yoke (3).
- c. Install pin (2) in bottom hole in articulation yoke (3), ensuring steering frame lock bolt (4) is below pin (2).
- d. Install clip (1) in pin (2).

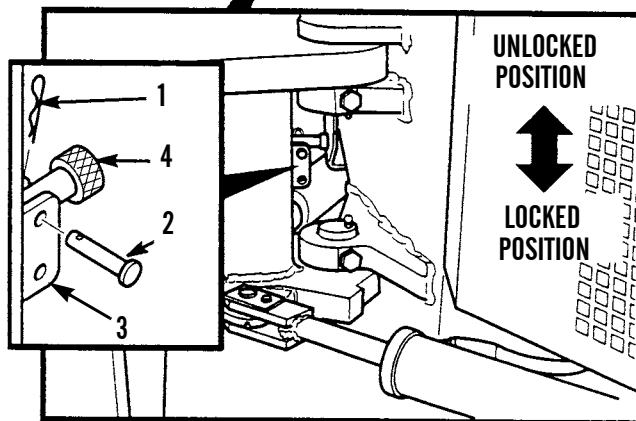

401-2166

3. **Adjust Handrails for Operation.** When rolling operations require operator to watch surfaces or edges of both drums, such as side-to-side rolling, operator station can be moved 90 degrees in either direction. Handrails can be moved out to make room for the seat to travel fully back while in 90-degree rotation. Size and space requirements of the operator will determine if adjustment of handrails is needed. Refer to WP 0022 00 when handrail adjustment is required.

INITIAL ADJUSTMENTS AND DAILY CHECKS - CONTINUED4. Adjust Seat.**WARNING**

Lock seat in position before operating roller to prevent unexpected seat movement. Failure to follow this warning may cause injury.

NOTE

- Adjust seat at the beginning of each shift or when changing operators.
 - Adjust seat until all controls can be comfortably reached when operator's back is against seat.
- a. Sit on seat (5), facing forward with your back against seat.
 - b. Move and hold fore-aft lever (6) to left, away from seat (5).
 - c. Slide seat (5) forward or backward to a position where all operator station controls can be comfortably reached.
 - d. Release fore-aft lever (6) to lock seat in position. Rock back and forth to ensure seat is locked into position.
 - e. Turn knob (7) until indicator (8) is flush with tube (9).
 - f. Lift lever (10) and adjust seat height to a position where all operator station controls can be comfortably reached.
 - g. Release lever (10).

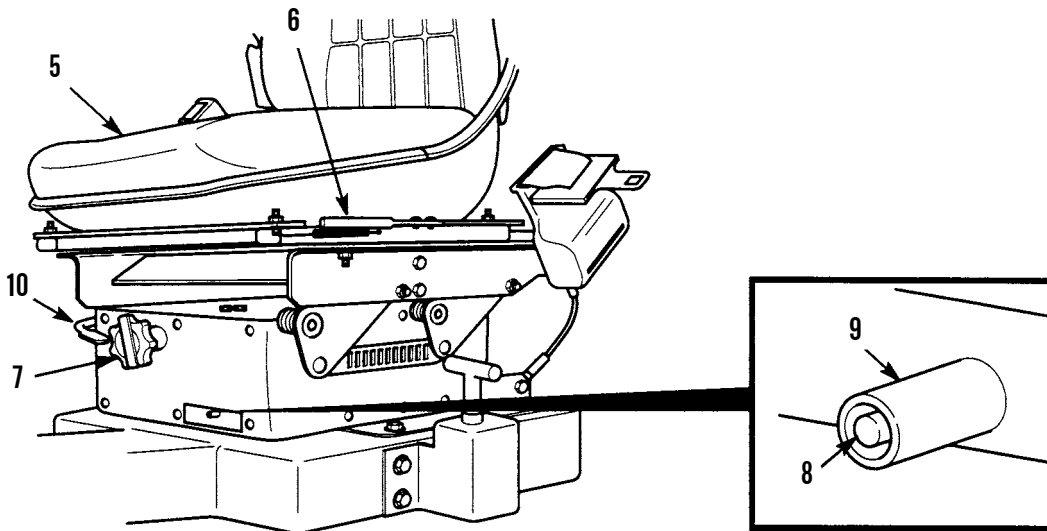

401-036

INITIAL ADJUSTMENTS AND DAILY CHECKS - CONTINUED

5. Operate Seat Belt.

WARNING

Use of seat belt while operating roller is mandatory. Fasten belt BEFORE driving. Trying to fasten belt while driving creates a hazardous condition. Failure to follow this warning may result in injury or death.

a. **Fasten Seat Belt.**

- (1) Sit on seat (5), hold gripper (11) and extend seat belt (12) from retractor (13).
- (2) Insert extrusion (14) into buckle (15) until securely latched.

b. **Unfasten Seat Belt.**

- (1) Push button (16) and remove extrusion (14) from buckle (15).
- (2) Allow seat belt (12) to slowly retract into retractor (13).

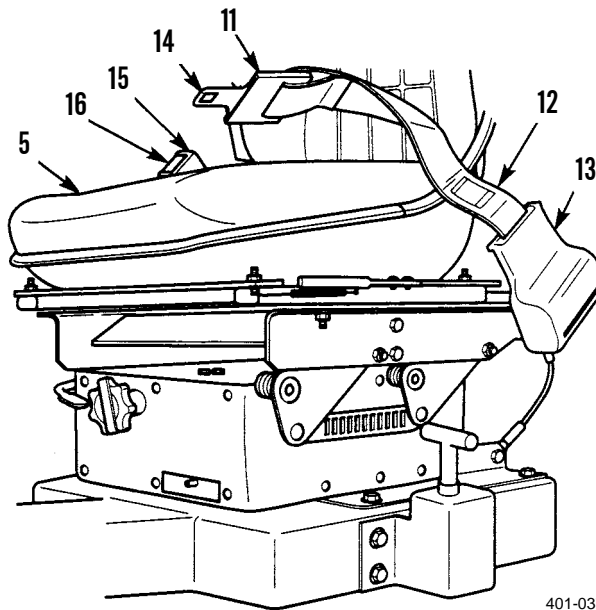

401-037

6. Adjust Operator Station Position.

WARNING

Do NOT operate roller with operator station in unlocked position. Failure to follow this warning may cause injury or death.

NOTE

When rolling operations require operator to watch surfaces or edges of both drums, such as side-to-side rolling, operator station can be moved 90 degrees in either direction. Holes are provided to lock operator station in 45-degree or 90-degree position.

- a. Pull lever (17) up and move operator station (18) to desired position.
- b. Align bottom top of lever (17) with hole in operator platform (19).
- c. Release lever (17) to lock operator station (18) in position.
- d. Ensure that lever (17) is securely seated in hole in operator platform (19).

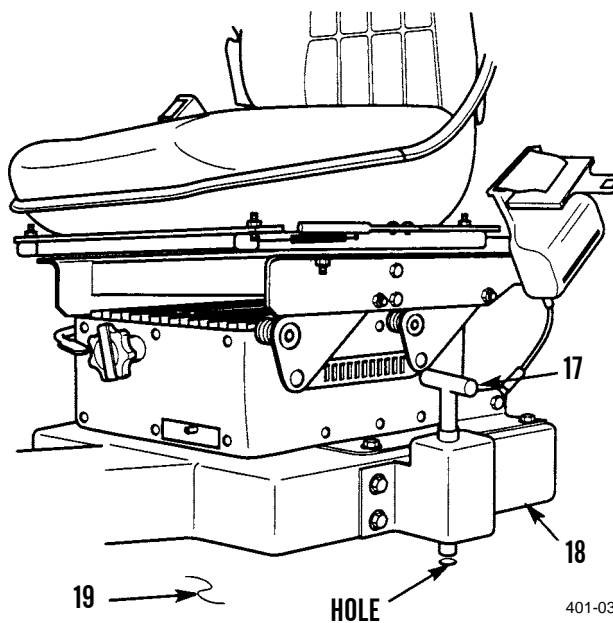

401-038

MOUNT AND DISMOUNT ROLLER**WARNING**

- Use caution when climbing on roller. Maintain three-point contact at all times and use rear steps and handrails. Be aware that footing may be slippery. Mount and dismount roller only where steps and handrails are provided. Failure to follow this warning may result in injury or death.
- Rollover Protection System (ROPS) canopy has 55 in. (139.7 cm) clearance above operator platform at lowest point. Use care when mounting or dismounting roller to prevent injury to head.
- Ensure that left-side door assembly and latch are securely closed before attempting to mount or dismount operator platform. Failure to follow this warning may cause injury.

1. Mount Roller.

- a. Stand facing roller (1).
- b. Using handrails (2) and steps (3), climb onto operator platform (4).

2. Dismount Roller.

- a. Grasp handrails (2) and turn to face center of roller (1).
- b. Using handrails (2) and steps (3), climb off operator platform (4) to ground.

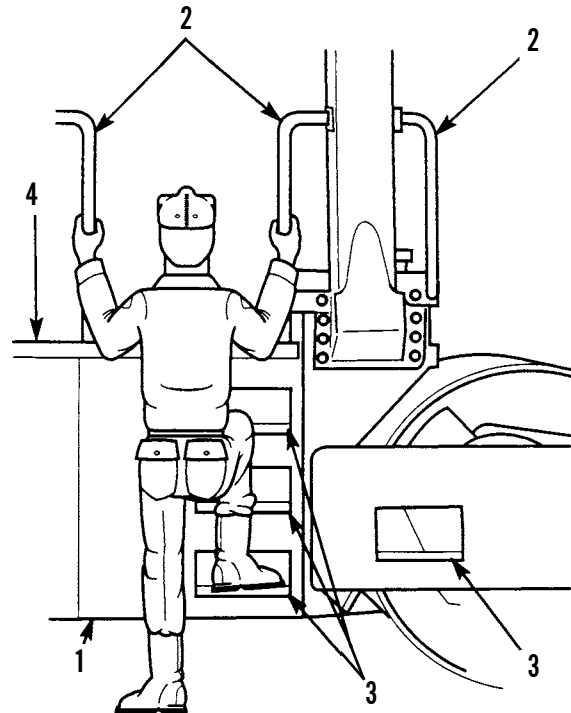

401-039

OPERATE ENGINE**WARNING**

- Your hearing can be **PERMANENTLY DAMAGED** if you are exposed to constant high noise levels of 85 DB or greater. Hearing protection is required when operating roller or when working on roller while it is operating. Failure to wear hearing protection may result in hearing loss.
- There is no clearance for personnel between frame and yoke when roller turns. Severe injury or death from crushing could occur.
- Steering frame must be locked before lifting, transporting, or servicing roller in articulation area to prevent injury or death from crushing.
- Unlock steering frame before operation to prevent loss of steering that may cause injury or death.

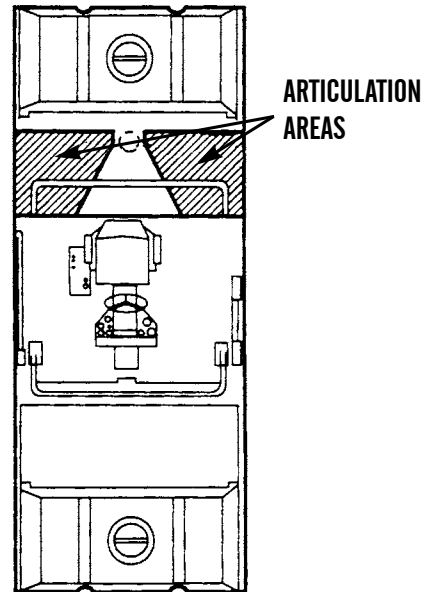

OPERATE ENGINE - CONTINUED1. **Turn On Battery Disconnect Switch.****NOTE**

Turn battery disconnect switch on at the beginning of each work day.

- a. Lift latch (1), push handle (2) toward front of roller (3) and open right-side door assembly (4).
- b. Unhook lanyard (5) from door assembly (4) and hook lanyard to frame assembly (6).
- c. Insert and turn key (7) until battery disconnect switch (8) is in connected position.
- d. Unhook lanyard (5) from frame assembly (6) and hook lanyard to door assembly (4).
- e. Close right-side door assembly (4), push handle (2) into latch (1) and close latch.

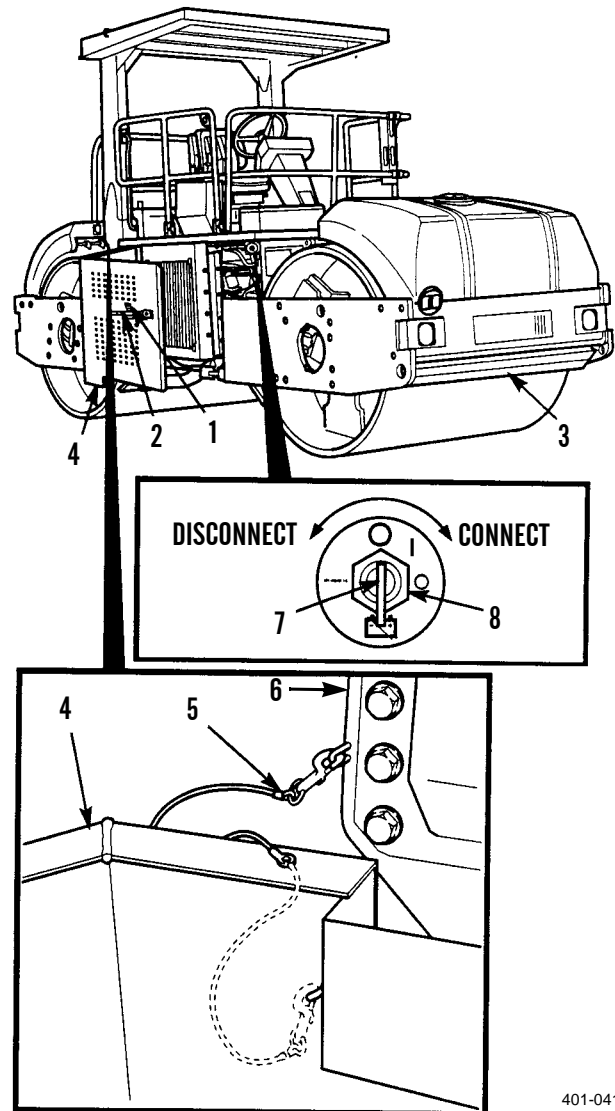

401-041

OPERATE ENGINE - CONTINUED2. **Start Engine [Above 32°F (0°C)].**

- a. Push down parking brake knob (9) to ensure parking brake is engaged.

NOTE

Engine will not start unless propel control lever is in NEUTRAL position.

- b. Move propel control lever (10) to NEUTRAL position (center).
- c. Move water spray switch (11) to OFF (center) position.
- d. On CB534B Roller only, turn throttle lock (12) counterclockwise until throttle control (13) moves up and down freely.
- e. On CB534B Roller, push and hold button (14) and pull throttle control (13) out to high idle position (near to or fully up).
- f. On CB534C Roller, move throttle control switch (15) to fast (HARE) position.

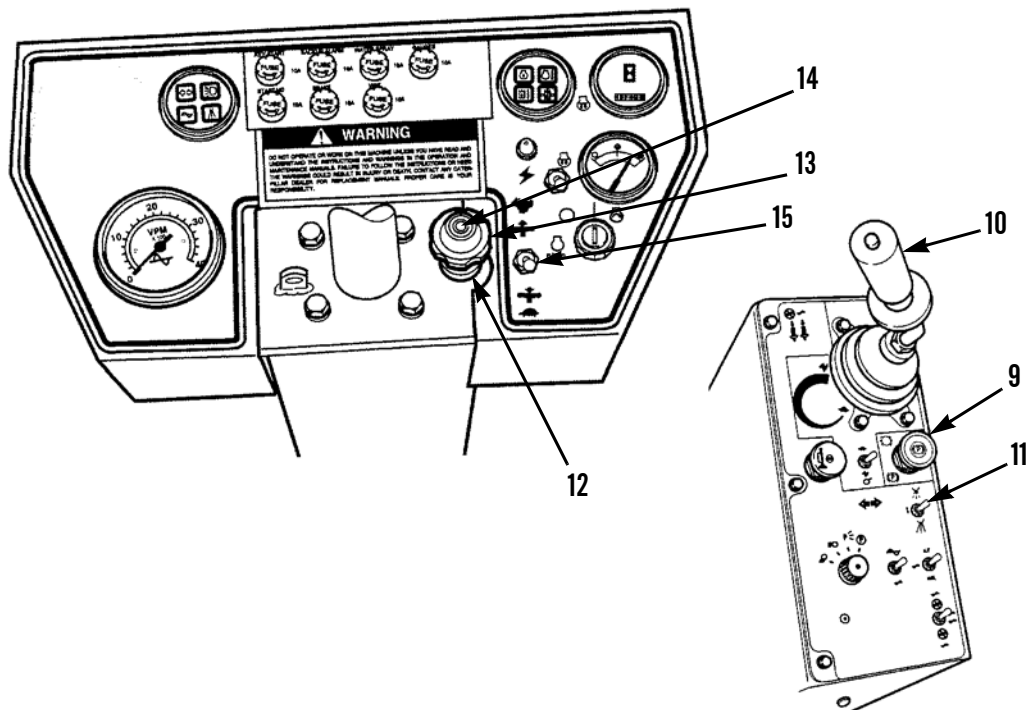

401-2228

OPERATE ENGINE - CONTINUED**WARNING**

DO NOT start roller engine in enclosed areas without adequate ventilation. Failure to follow this warning may result in permanent brain damage or death due to carbon monoxide poisoning.

CAUTION

- DO NOT operate starter motor for more than 30 seconds at a time. After 30 seconds, allow starter motor to cool for at least two minutes before attempting to start engine again. Excessive heating of starter motor may result in damage or early starter failure.
 - Keep engine rpm low until engine oil pressure indicator light and horn go off. Stop engine if indicator light does not go off within ten seconds. Notify supervisor to perform troubleshooting before restarting engine.
 - Failure to keep engine rpm low until engine oil pressure indicator light and horn go off can result in turbocharger damage.
- g. Turn engine start switch key (16) to START (clockwise) position to crank engine. Release key when engine starts.
- h. On CB534B Roller only, immediately push and hold button (14) and push throttle control (13) down to low idle position (near to or fully down) for engine warm up. Release button.
- i. On CB534B Roller only, when desired low idle is reached, turn throttle lock (12) clockwise to lock throttle control (13) in position.
- j. On CB534C Roller only, push throttle control switch (15) to slow (TORTOISE) position once engine is started.

NOTE

Vibration push switch turns vibratory system on by pressing once or off by pressing again. There is no way to tell if the vibratory system is on or off when the engine is not running.

- k. Ensure that vibration push switch (17) is turned off.

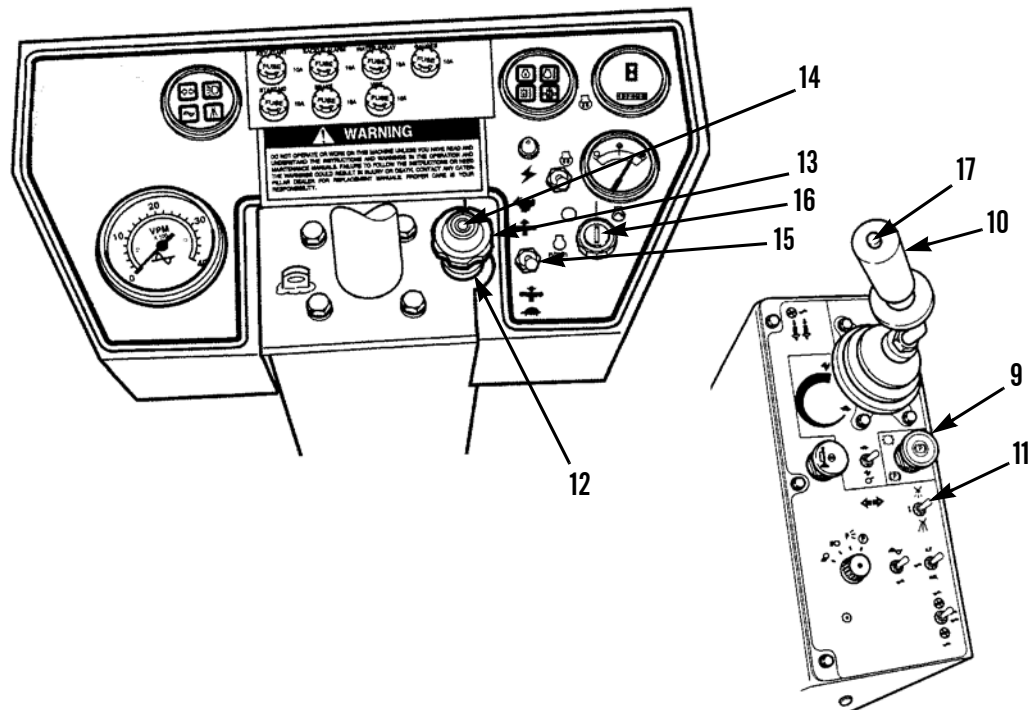
OPERATE ENGINE - CONTINUED

401-2228

3. **Warm Up Engine [Above 32°F (0°C)].****CAUTION**

Keep engine rpm low until engine oil pressure warning light goes out. If oil pressure gauge does not indicate oil pressure or engine oil indicator light does not go out within ten seconds, stop engine and investigate cause before starting again.

- a. Observe the following guidelines for engine warm up:
 - (1) If temperature is greater than 32°F (0°C), warm up engine for approximately 15 minutes.
 - (2) If temperature is less than 32°F (0°C), warm up engine for approximately 30 minutes.
 - (3) If temperature is less than 0°F (-32°C) or if hydraulic functions are sluggish, additional time may be required.
- b. Allow a cold engine to warm up at low idle for a minimum of five minutes. Complete warm up requires approximately 15 minutes in temperatures above 32°F (0°C).
- c. Observe warning and indicator lights frequently during warm up.
- d. Cycle all steering and propel controls several times to allow warm hydraulic oil to circulate through all cylinders and lines.

OPERATE ENGINE - CONTINUED4. **Shut Down Engine.****CAUTION**

Stopping engine immediately after it has been working under load can cause overheating and accelerated wear of engine components. Failure to run engine at low idle for five minutes after operation may cause damage to engine.

NOTE

Engine shutdown is the same for CB534B and CB534C Rollers. CB534B Rollers is shown.

- a. With roller stopped, run engine at low idle for five minutes.
- b. Turn engine start switch key (16) to OFF position. Remove key from switch.

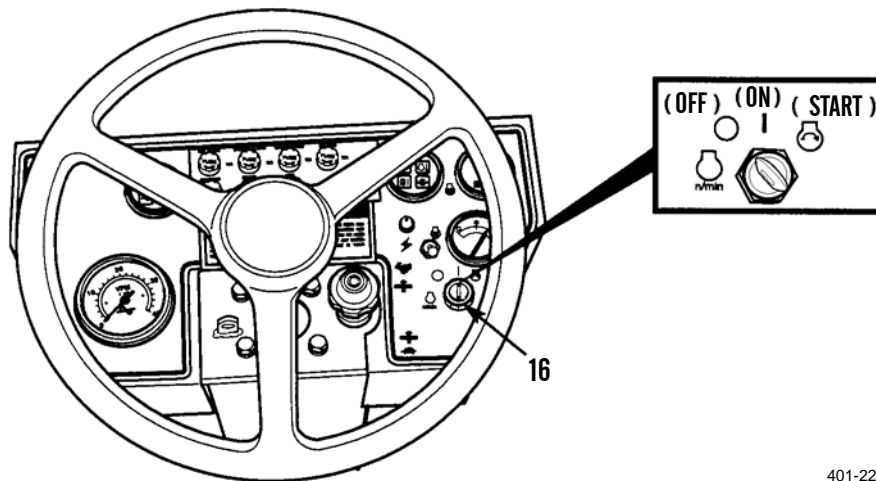

401-2214

OPERATE ENGINE - CONTINUED5. **Turn Off Battery Disconnect Switch.****NOTE**

Turn battery disconnect switch off at the end of each work day.

- a. Lift latch (1), push handle (2) toward front of roller (3) and open right-side door assembly (4).
- b. Unhook lanyard (5) from door assembly (4) and hook lanyard (5) to frame assembly (6).
- c. Turn key (7) until battery disconnect switch (8) is in OFF position. Remove key.
- d. Unhook lanyard (5) from frame assembly (6) and hook lanyard to door assembly (4).
- e. Close right-side door assembly (4), push handle (2) into latch (1) and close latch.

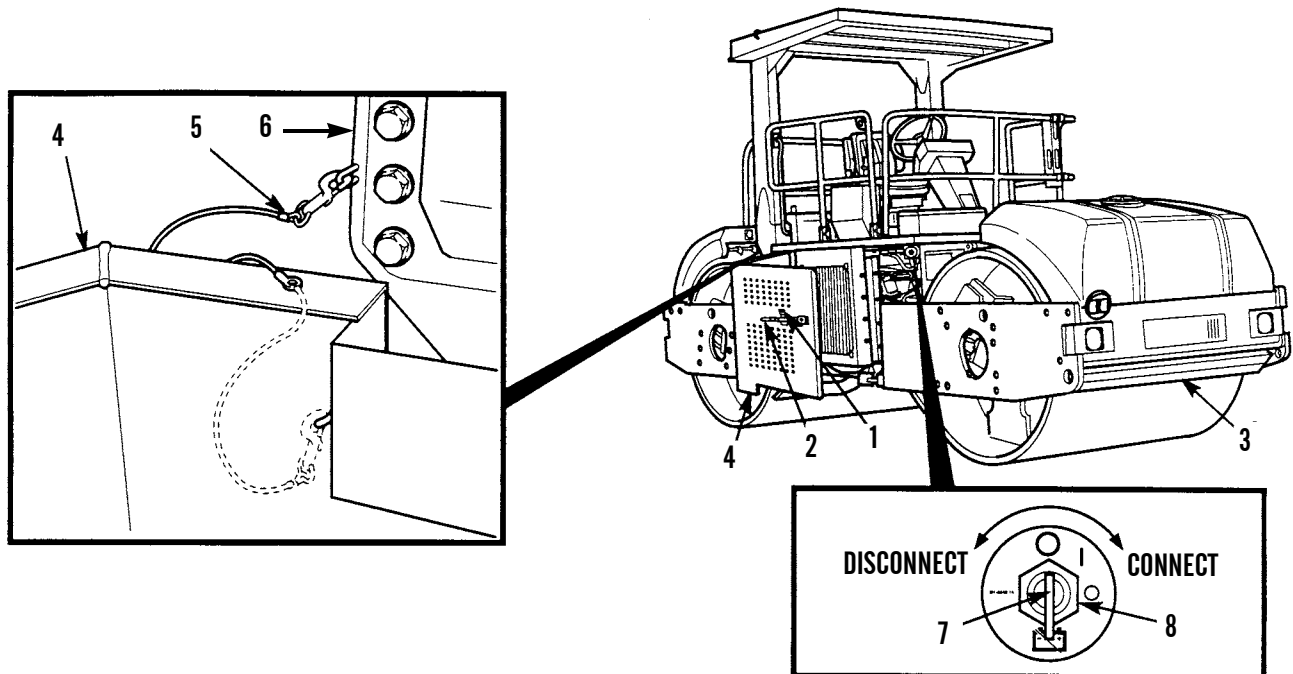

401-044

OPERATE WATER SPRAY SYSTEM

NOTE

Water spray system is operated the same way for CB534B and CB534C Rollers. CB534B Roller is shown.

1. **Check Water Tank Level.**

CAUTION

Water spray system must be drained at the end of each work day and filled at the beginning of the next work day. Draining ensures the removal of debris or biological growth and prevents damage to the system in the event of freezing temperatures.

- a. Observe water level at front and rear water level gauges (1).

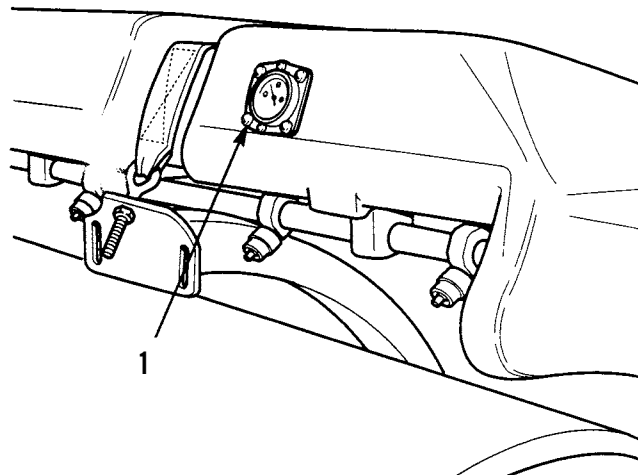

401-045

CAUTION

Operating water spray system for prolonged periods without water in tanks will result in damage to water spray pumps.

- b. When required, fill water tanks (WP 0024 00).

2. **Operate Water Spray System.**

CAUTION

- Always check level in water tanks prior to operating water spray system. Failure to follow this caution may cause damage to water spray system.
- Contaminated water can cause performance and reliability problems in water spray system.

NOTE

- Use continuous spray in high temperature and low humidity conditions to keep drums wet.
 - Use intermittent water spray to conserve water.
- a. For intermittent water spray, move water spray switch (2) to forward position.
 - b. For continuous water spray, move water spray switch (2) to rear position.

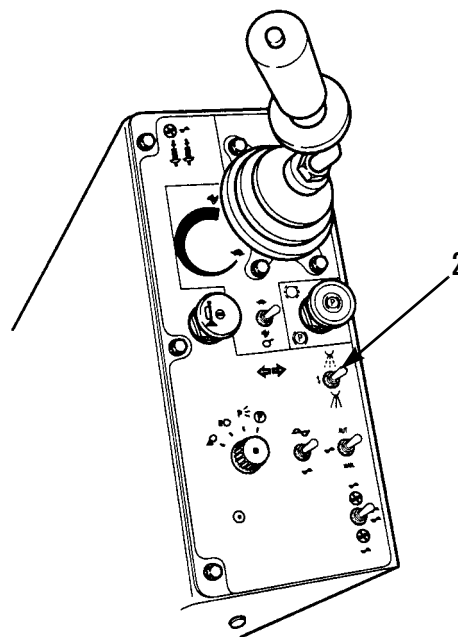

401-046

OPERATE WATER SPRAY SYSTEM - CONTINUED3. **Override Failed Water Spray System Pump.****NOTE**

- Water spray system consists of two identical but separate systems located at each end of the roller. If pump of one system fails, operator can open the tie-line valve to supply water flow to both systems.
 - For the CB534C Roller, use switches on operator console to select proper pump and tank for use. Refer to WP 0005 00.
- a. Lift latch (3), pull handle (4) toward front of roller (5) and open right-side door assembly (6).
 - b. Unhook lanyard (7) from door assembly (6) and hook lanyard to frame assembly (8).
 - c. Turn tie-line valve (9) to OPEN position.
 - d. Unhook lanyard (7) from frame assembly (8) and hook lanyard to door assembly (6).
 - e. Close right-side door assembly (6), push handle (4) into latch (3) and close latch.

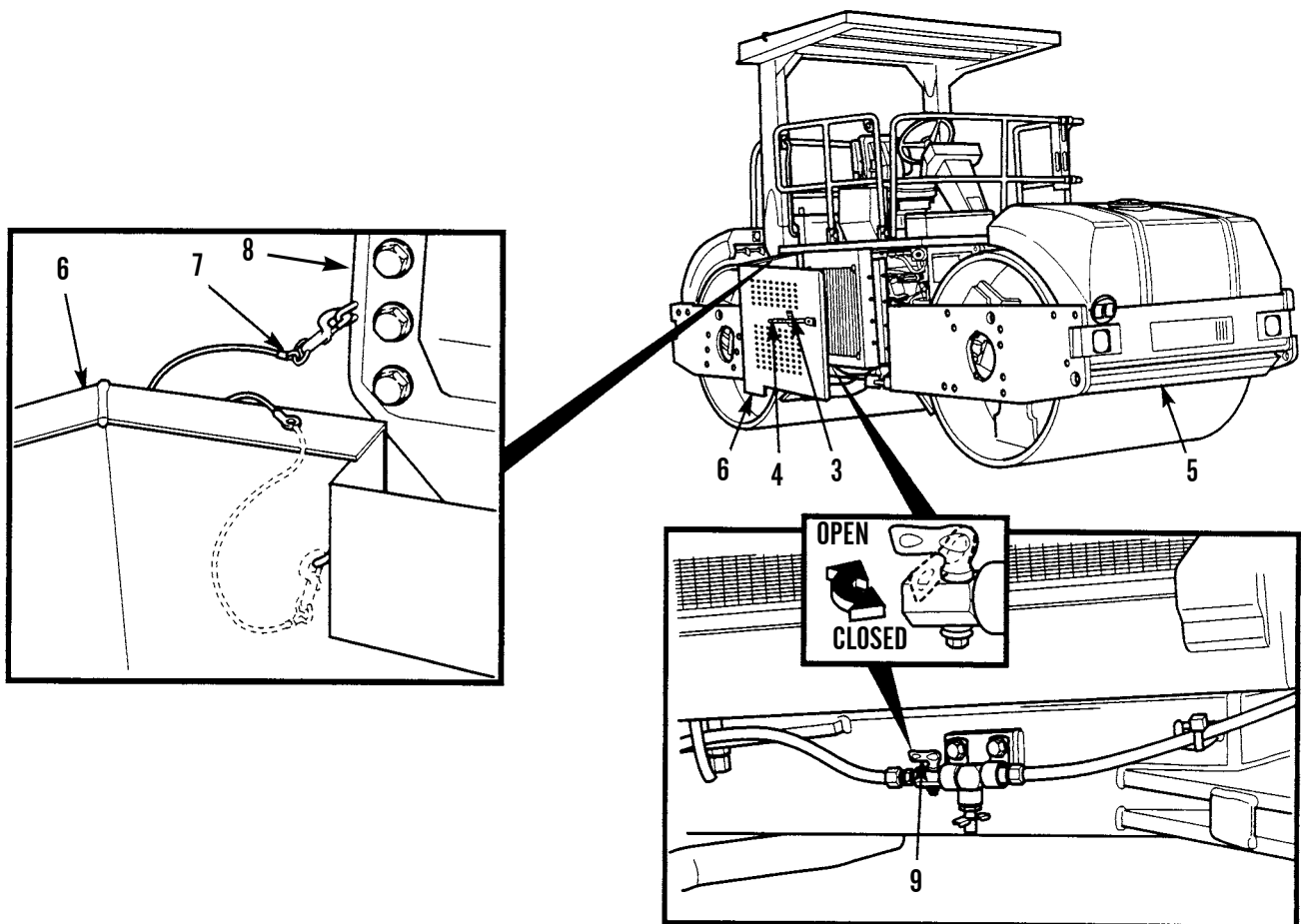

401-047

OPERATE WATER SPRAY SYSTEM - CONTINUED

4. **Turn Water Spray System Off.**
 - a. Move water spray switch (2) to center position.

CAUTION

Water spray system must be drained at the end of each work day and filled at the beginning of the next work day. Draining ensures the removal of debris or biological growth and prevents damage to the system in the event of freezing temperatures.

- b. Drain water tanks (WP 0024 00) at the end of each work day.

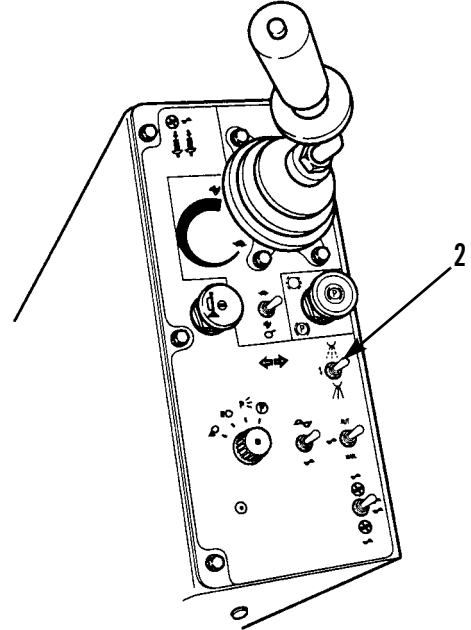

401-046

OPERATE VIBRATORY SYSTEM**WARNING**

Do not operate roller for periods longer than 3 hours. Operator may resume 3 hour period of roller operation after 1 hour of rest. Operating roller for periods longer than 3 continual hours may cause injury to personnel from exposure to high whole-body vibration levels.

NOTE

Operation of vibratory system is the same for CB534B and CB534C Rollers. CB534B Roller is shown.

1. **Select Front or Rear Drum.**
 - a. Move drum select switch (1) to activate vibratory system to front drum.
 - b. Move drum select switch (1) to center position to activate vibratory system to both drums.
 - c. Move drum select switch (1) to rear to activate vibratory system to rear drum.

OPERATE VIBRATORY SYSTEM - CONTINUED2. **Select Manual or Automatic Mode.****NOTE**

In automatic mode, vibratory system activates automatically when propel control lever is moved to forward or reverse position. The speed needed to activate vibratory system can be adjusted by Field Maintenance.

- a. Move the vibratory control switch (2) forward to activate the vibratory system in the automatic mode.

NOTE

When the vibration control switch is in the rear position, the vibratory system can be activated at any time, including while the roller is stopped.

- b. Move the vibratory control switch (2) to the rear position to activate the vibratory system in the manual mode.

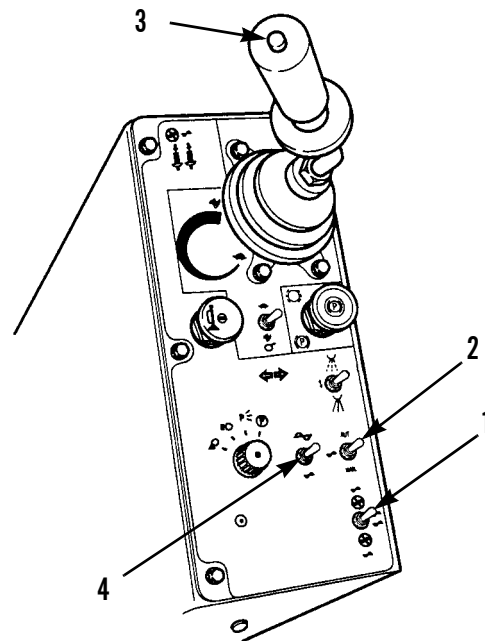
3. **Turn Vibratory System On and Off.**

401-046

WARNING

Do not turn vibratory system on while roller is standing still on a very solid surface. A loss of steering can be experienced which could result in injury.

CAUTION

Never start or stop the roller abruptly. Damage to the propel and braking systems can occur.

NOTE

When the vibration push switch is on, the vibratory system indicator light will be on while the engine is running.

- a. Press the vibration push switch (3) to turn the vibratory system on.
- b. Press the vibration push switch (3) again to turn the vibratory system off.

OPERATE VIBRATORY SYSTEM - CONTINUED4. **Amplitude Select Mode.****NOTE**

As the drum vibrates, it travels in an up and down motion. The vertical distance is called amplitude. This vertical movement is how the roller creates compaction of the surface material.

- a. Move the amplitude select switch (4) to the forward position to operate the vibratory system in the high pitch mode.
- b. Move the amplitude select switch (4) to the rear position to operate the vibratory system in the low pitch mode.

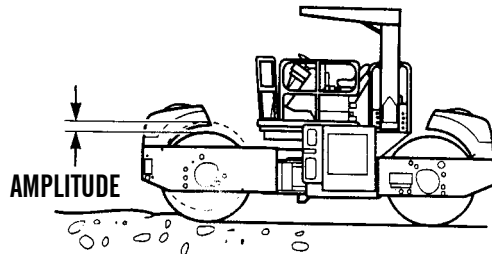

401-048

MOVE ROLLER**NOTE**

CB534B and CB534C Rollers are moved the same way. CB534B Roller is shown.

1. **Move Roller Forward.****NOTE**

Parking brake switch will be illuminated while parking brake is engaged.

- a. Pull up on parking brake switch (1) to disengage parking brake.
- b. Slowly push the propel control lever (2) forward, away from center, to move the roller forward.
- c. To move roller faster, push the propel control lever (2) further forward.

CAUTION

The following procedure should always be used to stop the roller, unless an emergency situation exists. Damage to equipment can occur if parking brake is used to stop roller.

2. **Stop Roller.** Move the propel control lever (2) to the center position to stop the roller.

3. **Move Roller in Reverse.**

- a. Slowly pull the propel control lever (2) back, away from center, to move the roller in reverse.
- b. To move roller faster, pull the propel control lever (2) further back.

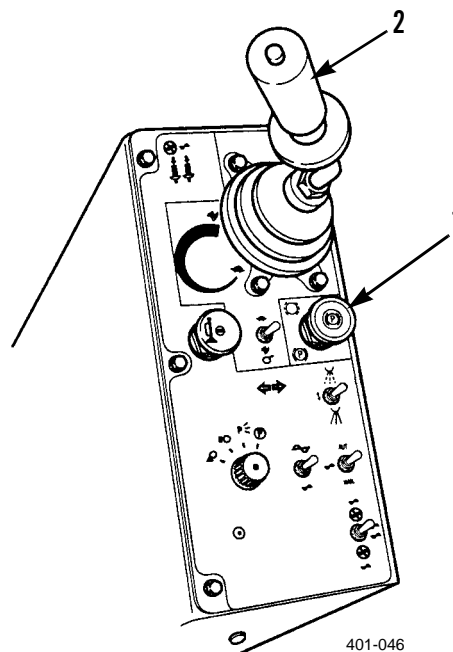

401-046

ROLLING PROCEDURES

WARNING

- Operator shall not operate roller for periods longer than 3 hours. Operator may resume 3 hour period of roller operation after 1 hour of rest. Operating roller for periods longer than 3 continual hours may cause injury to personnel from exposure to excessive body vibration levels from roller.
- Do not turn roller vibratory system on while roller is standing still on a very solid surface. A loss of steering can be experienced which could result in injury to personnel.

CAUTION

The following procedure should always be used to stop the roller, unless an emergency situation exists. Damage to equipment can occur if parking brake is used to stop roller.

NOTE

Turn vibration system off before stopping on hot asphalt.

1. **Roll with Both Drums Static.** Vibration may not be used at all on thin overlays of 1 in. (25 mm) or less. The roller can also be run in the static mode for finish rolling to smooth out any drum marks.

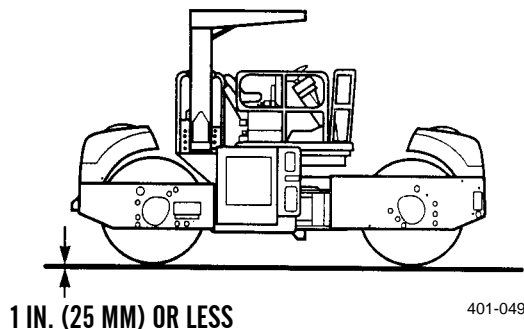

2. **Roll with Lead Drum Vibrating and Trailing Drum Static.** Some difficult asphalt mixes and mats less than 2 in. (50 mm) thick may require the operator to run with the lead drum vibrating and the trailing drum static.

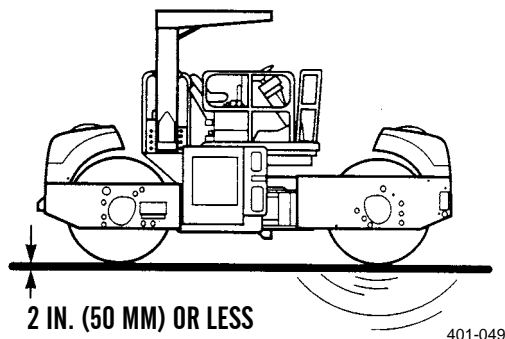

3. **Roll with Both Drums Vibrating.** For maximum compaction when the laydown thickness is greater than 2 in. (50 mm), roll with both drums vibrating.

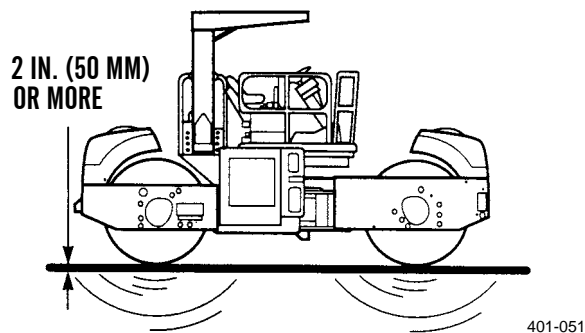

ROLLING PROCEDURES - CONTINUED**NOTE**

Turn vibration system off before stopping on hot asphalt.

4. **Roll with Lead Drum Static and Trailing Drum Vibrating.** Running with the lead drum static and the trailing drum vibrating is not recommended since the static drum will tend to push the material.

PARK ROLLER**NOTE**

CB534B and CB534C Rollers are parked the same way. CB534B Roller is shown.

1. Move roller to secure area on level ground.
2. Turn off vibratory system. Refer to *Operate Vibratory System* in this work package.
3. Move propel control lever (1) to the center position to stop roller.

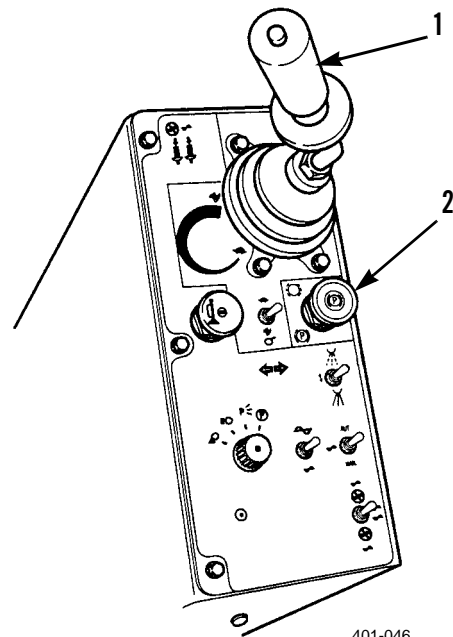
**NOTE**

Parking brake switch will be illuminated while parking brake is engaged and engine start switch is in ON position.

4. Press parking brake switch (2) to engage parking brake.

NOTE

Drain the water tanks at the end of each work day to prevent freezing and biological growth from occurring during periods of roller inactivity.

5. Turn off water spray system. Refer to *Operate Water Spray System* in this work package.
6. Shut down engine. Refer to *Operate Engine* in this work package.
7. Dismount roller. Refer to *Mounting and Dismounting Roller* in this work package.

NOTE

Battery disconnect switch should be turned off at the end of each work day.

8. Ensure that battery disconnect switch is turned off and key is removed. Refer to *Operate Engine* in this work package.

CHOCK DRUMS**NOTE**

- Chock front and rear of each drum to prevent movement.
 - Before unchocking drums, ensure parking brake is applied.
1. Chock front and rear drums whenever maintenance is being performed on roller.
 2. Chock front and rear drums in accordance with local policy.
 3. When roller is operational, remove chocks.

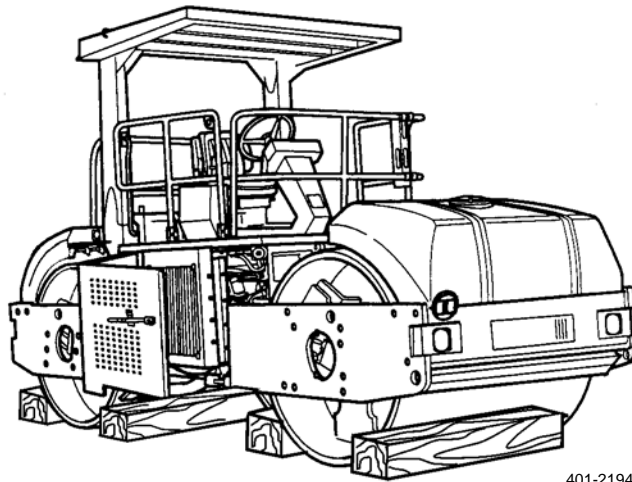

401-2194

OPENING/CLOSING DOOR ASSEMBLIES**WARNING**

- There is no clearance for personnel between frame and yoke when roller turns. Injury or death from crushing could occur.
- Steering frame must be locked before lifting, transporting or servicing roller in articulation area to prevent injury or death from crushing.

NOTE

Right and left-side door assemblies are opened and closed the same way. Right-side door assembly is shown.

1. **Open Door Assembly.**

- If opening door to check or service engine compartment with engine running, shut off engine and lock steering frame. Refer to *Initial Adjustments and Daily Checks* and *Operate Engine* in this work package.
- Lift latch (1), pull handle (2) up and toward front of roller (3) and open door assembly (4).
- Unhook lanyard (5) from eye on door assembly (4) and hook to eye on frame assembly (6).

2. **Close Door Assembly.**

- Unhook lanyard (5) from frame assembly (6) and hook to door assembly (4).
- Close and hold door assembly (4), tightly against frame.
- Push handle (2) into latch (1) and close latch.
- If steering frame was locked, shut off engine and unlock steering frame. Refer to *Initial Adjustments and Daily Checks* and *Operate Engine* in this work package.

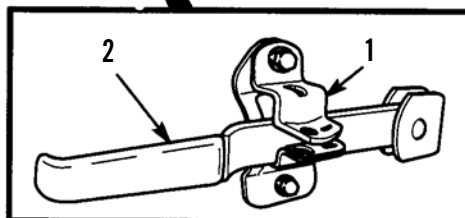
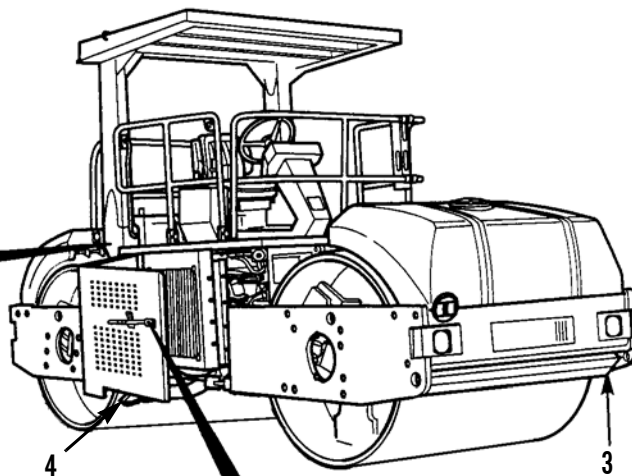
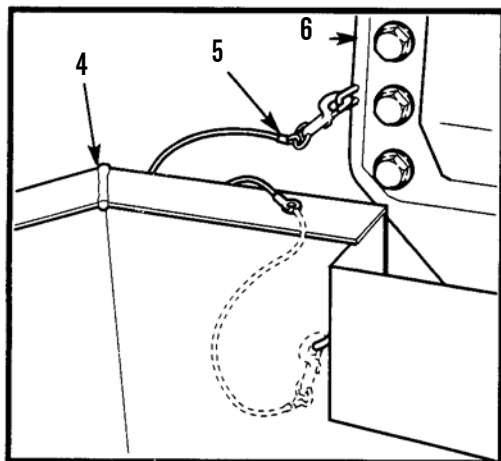

401-2193

ROADING MACHINE

1. Perform a walk-around inspection of roller.
2. Measure fluid levels in various compartments (WP 0011 00 and WP 0012 00).
3. Check with proper officials to obtain required licenses.
4. Install any required flags, signals and lights.
5. Travel at moderate speed and observe all roller speed limitations.
6. If traveling a long distance, stop roller after 30 minutes to allow roller to cool down.

TOWING INSTRUCTIONS**WARNING**

- Before towing, ensure tow bar is in good working condition. Use of a weak tow bar could result in injury or death.
- Incorrectly towing a roller may cause injury or death.
- Do not allow an operator on roller unless engine is running and the operator can control steering and/or braking. Uncontrolled roller may cause injury or death.
- Do not use a chain or cable for pulling. A chain or cable link can break causing injury.
- The towing vehicle should be as large or larger than the roller. Any vehicle used to tow the roller shall have enough brake capacity, weight, and power to control both vehicles for the grade and distance involved.
- To provide sufficient control and braking when moving a disabled roller downhill, a larger towing vehicle, or additional vehicles, connected to the rear of the towed roller is required.
- Turning on a slope will reduce the stability of both the towing vehicle and the towed roller and could result in a tip-over accident.

NOTE

When towing, attach tow bar to tiedown points.

NOTE

- Towing instructions are for moving a disabled roller a short distance at a low speed, not faster than 1.2 mph (2 km/h), to a convenient location for repair or transport. These instructions are for emergencies only. Always transport roller when a long-distance move is required.
- The roller can be towed a short distance or can be pulled from the mud while the engine is running if the power train and steering system are working. The operator on towed roller must steer in direction of tow.
- CB534B Roller weighs 21,232 lb (9631 kg). CB534C Roller weighs 21,832 lb (9903 kg). Attach tow bar with a minimum capacity of 21,232 lb (9631 kg) to CB534B Roller. Attach tow bar with a minimum capacity of 21,832 lb (9903 kg) to CB534C Roller.

TOWING INSTRUCTIONS - CONTINUED

1. If the engine is not running, manually release parking brake (WP 0006 00).
2. Refer to FM 9-43-2 and attach tow bar to roller at tiedown points.
3. Attach tow bar to towing vehicle.
4. Refer to FM 9-43-2 and slowly tow the disabled roller.

PREPARATION FOR TRANSPORT**NOTE**

- Preparation for transport procedures are the same for CB534B and CB534C Rollers. CB534B Roller is shown.
- Obey all state and local laws governing characteristics of a load (height, weight, width and length). Observe all regulations governing wide loads.
- Ensure that cooling system has proper antifreeze mix if transporting roller to a colder climate.

1. General Transport Instructions.

- a. Investigate travel route for overpass clearances. Ensure that there is adequate clearance for roller being transported. Refer to WP 0002 00 for roller dimensions.
- b. Before loading roller, remove ice, snow and other slippery material from loading dock and truck bed to prevent slippage of roller and shifting while in transit.
- c. Before loading roller, place chock block in front of and behind trailer or railcar wheels. Apply parking brake.
- d. Travel at moderate speed and observe all speed limitations when transporting roller.

PREPARATION FOR TRANSPORT - CONTINUED

2. **Lift Machine onto Shipping Bed.**

NOTE

Refer to *Equipment Data* in WP 0002 00 and roller shipping date plate (WP 0007 00) for information on roller dimensions and weights and for instructions on lift points.

- a. Ensure that all water tanks are empty (WP 0024 00).

WARNING

Steering frame must be locked before lifting roller, to prevent injury or death from crushing.

- b. Lock steering frame as follows.
 - (1) Remove clip (1) and pin (2) from articulation yoke (3).
 - (2) Position steering frame lock bolt (4) to bottom of slot in articulation yoke (3).
 - (3) Install pin (2) in bottom hole in articulation yoke (3), ensuring steering frame lock bolt (4) is below pin (2).
 - (4) Install clip (1) in pin (2).
- c. Position crane or other lifting device so that roller will be lifted in level position.

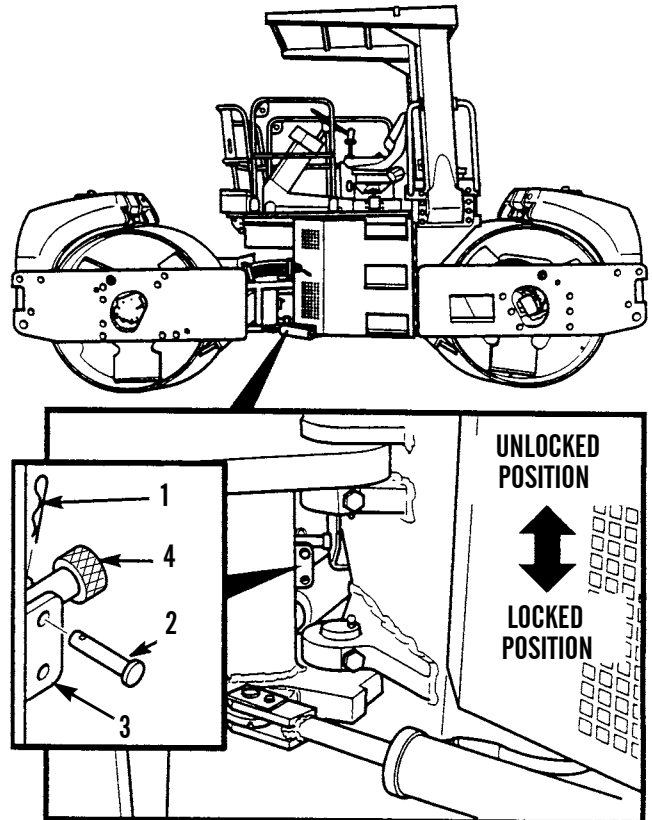

401-2166

PREPARATION FOR TRANSPORT - CONTINUED**WARNING**

- Lifting equipment used for lifting roller must be in good condition and of suitable load capacity. Failure to follow this warning may result in injury, death or damage to roller.
- Improper use of lifting equipment and improper attachment to roller can result in injury or equipment damage. Observe all standard rules of safety.
- Use caution when handling heavy parts. Provide adequate support and use assistance during procedure. Ensure that any lifting device used is in good condition and of suitable load capacity. Keep clear of heavy parts supported only by lifting device. Failure to follow this warning may cause injury or death.

NOTE

- CB534B Roller weighs 21,232 lb (9631 kg).
 - CB534C Roller weighs 21,832 lb (9903 kg).
 - Lifting eyes are identified by a label that shows a hook and/or the stencil "LIFT HERE".
- d. Attach crane or other suitable lifting device to front and rear lifting eyes (5) on both sides of roller.
 - e. Lift roller slowly to ensure roller stays level.
 - f. Position roller on shipping bed of transport vehicle or railcar.

CAUTION

Blocks are placed to prevent excessive loads on drum support bearings. Failure to chock drums may result in damage to roller.

- g. When roller is in position, place blocks high in center of yoke on each side of roller in front and rear. Chock drums. Refer to *Chock Drums* in this work package.

PREPARATION FOR TRANSPORT - CONTINUED

- h. Press parking brake switch (6) to apply parking brake.
- i. Turn engine start switch (7) to OFF position and remove key.
- j. Turn off battery disconnect switch. Refer to *Operate Engine* in this work package.

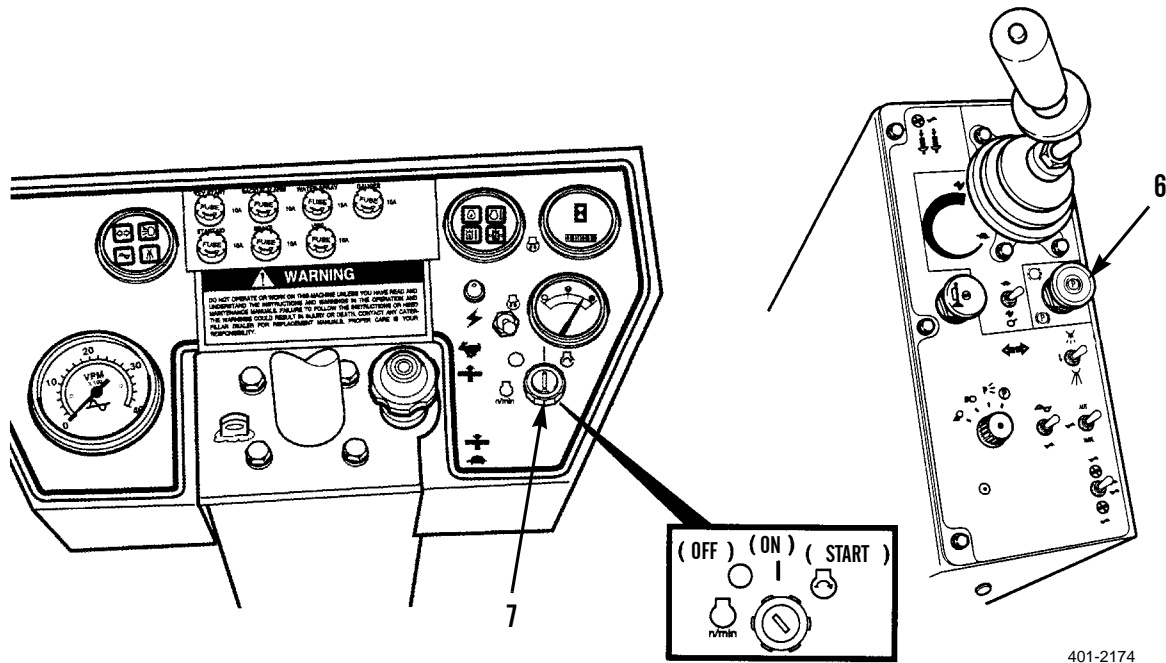

- k. Ensure that all locks and vandal guard (8) are in place and secure.

CAUTION

Exhaust opening must be closed prior to shipping. Turbocharger damage can result if the turbocharger rotates without the engine running.

- l. Cover exhaust opening (9) with tape to prevent debris from entering exhaust system and turbocharger and to prevent turbocharger from rotating
- m. Proceed to *Tie Down Roller* in this work package.

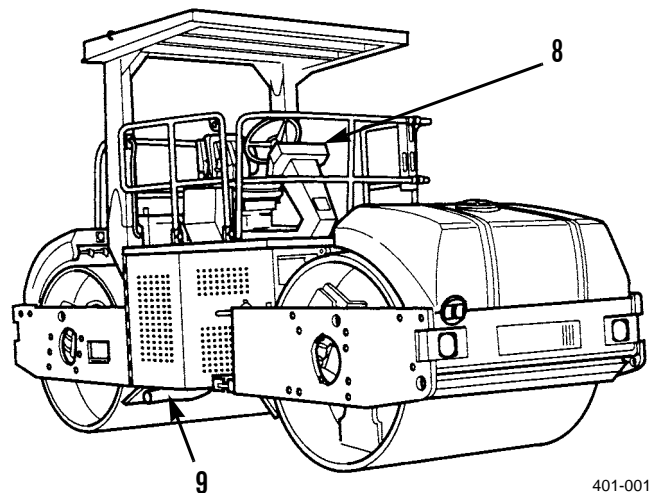

PREPARATION FOR TRANSPORT - CONTINUED3. **Load Roller onto M870 Series Trailer.****CAUTION**

To prevent damage to roller drum surface areas during loading and unloading, it is necessary to construct a trailer approach ramp. Refer to TM 5-2330-378-14&P. This ramp must be utilized during loading and unloading operations.

- a. Construct a trailer approach ramp utilizing oak planks provided as BII with trailer.
- b. Slowly move roller forward and up on to approach ramp. When roller is in position on trailer bed, do the following:
 - (1) Apply parking brake. Refer to *Operate Engine* in this work package.
 - (2) Turn the engine start switch to OFF position and remove key. Refer to *Operate Engine* in this work package.
 - (3) Turn battery disconnect switch to OFF position. Refer to *Operate Engine* in this work package.
 - (4) Ensure that all locks and vandal guard are in place and secure. Refer to *Lift Machine onto Shipping Bed* in this work package.

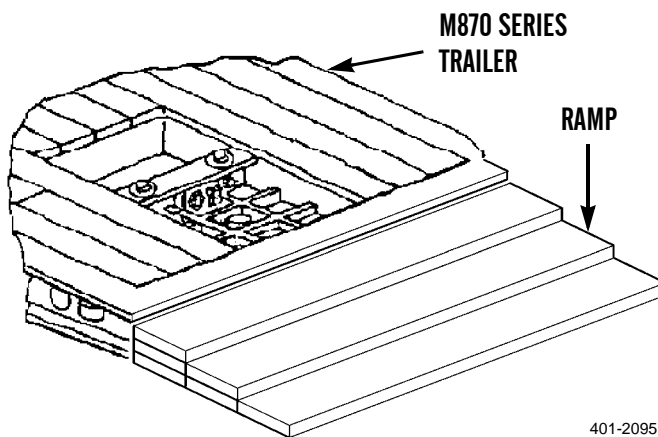
**CAUTION**

Exhaust opening must be closed prior to shipping. Turbocharger damage can result if the turbocharger rotates without engine running.

- (5) Cover exhaust opening with tape to prevent debris from entering exhaust system and turbocharger, and to prevent turbocharger from rotating.

PREPARATION FOR TRANSPORT - CONTINUED

4. **Tie Down Roller.**



WARNING

Improper lifting or tiedowns can allow load to shift. Use slings rated for a minimum of 21,232 lb (9631 kg) for the CB543B Roller. Use slings rated for a minimum of 21,832 lb (9903 kg) for the CB534C Roller. Failure to follow this warning may cause injury, or damage to equipment.

Secure roller by using tie down locations (10) at each corner of roller.

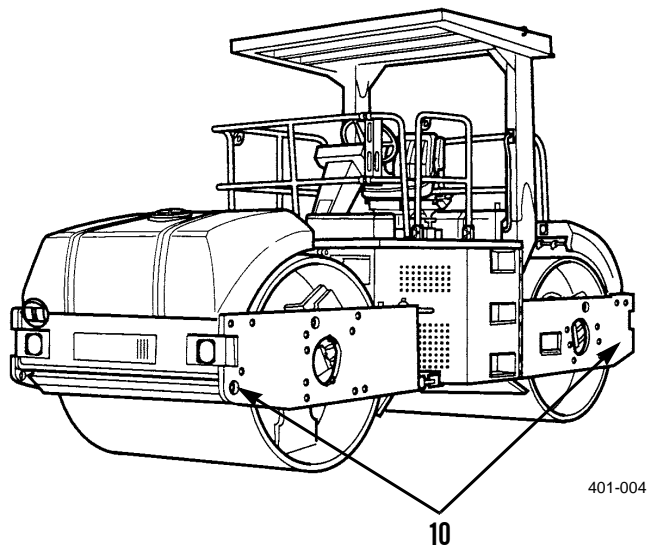
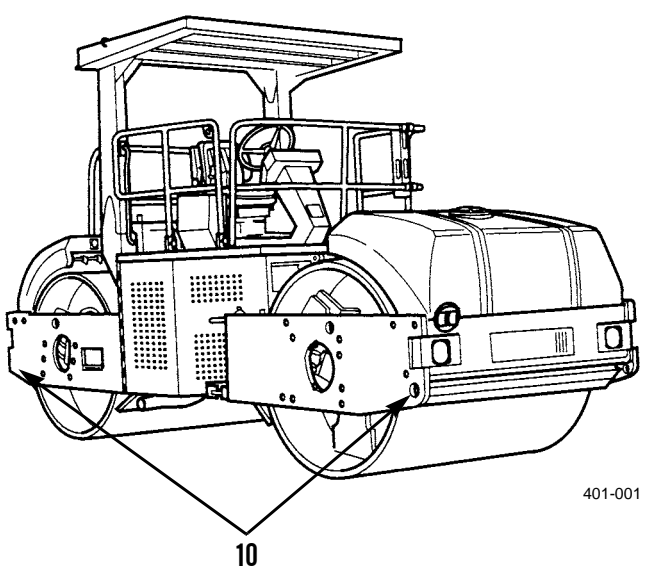

END OF WORK PACKAGE

GENERAL**WARNING**

Operators must wear protective head gear. Failure of operators to wear protective head gear may result in serious injury or death.

This work package contains instructions for safely operating the CB534B and CB534C Rollers, Motorized, Vibrating Tandem Steel Drums under unusual conditions. In addition to normal preventive maintenance, special care must be taken to keep roller operational in extreme temperatures and other environmental conditions.

SLAVE START ROLLER**WARNING**

- When slave starting roller, use NATO slave cable that DOES NOT have loose or missing insulation.
- DO NOT proceed with slave starting if correct slave cable is not available.

CAUTION

- DO NOT allow “live” machine and “dead” roller to come in contact with each other during slave starting. Failure to follow this caution may cause electrical system damage.
- Under no circumstances can the roller be started by being towed or pushed. Failure to follow this caution will damage roller.

NOTE

- If machine other than another roller is used to slave start machine, refer to Operator’s Manual for “live” machine, for any special slave starting procedures.
 - Slave start procedures are the same for CB534B and CB534C Rollers. CB534B Roller is shown.
 - Slave starting is a two-person task.
1. Start “live” machine with a good charging system and battery (refer to machine Operator’s Manual).
 2. Move “live” machine into position beside “dead” roller so NATO slave connectors on machine and roller are side-by-side.
 3. Shut down “live” machine (refer to “live” machine Operator’s Manual).

SLAVE START ROLLER - CONTINUED

4. Remove caps (1) from NATO connectors (2) on “live” machine and roller.



- To avoid injury, eye protection and acid-resistant gloves must be worn when working around batteries. Do not smoke, use open flame, make sparks or create other ignition sources around batteries. If a battery is giving off gases, it may explode and cause injury. Remove all jewelry such as rings, ID tags, watches, and bracelets. If jewelry or a tool contacts a battery terminal, a direct short will result in instant heating, damage to equipment, and injury.
- Sulfuric acid contained in batteries can cause serious burns. If battery corrosion or electrolyte makes contact with skin, eyes or clothing, take immediate action to stop the corrosive burning effects. Failure to follow these procedures may result in injury or death.

5. Remove caps (3) from NATO slave cable connector (4).
6. Plug NATO slave cable connector (4) into NATO connectors (2) on “live” machine and roller.
7. Start “live” machine (refer to “live” machine’s Operator’s Manual).
8. Operate “live” machine at high idle (refer to “live” machine’s Operator’s Manual) while attempting to start roller engine (WP 0005 00).
9. When roller engine is running smoothly, remove NATO slave cable connectors (4) from NATO connectors (2) of “live” machine and roller.
10. Install caps (3) on NATO slave cable connectors (4).
11. Install caps (1) on NATO connectors (2) on “live” machine and roller.
12. Move and park “live” machine (refer to “live” machine’s Operator’s Manual).
13. Shut off “live” machine (refer to “live” machine’s Operator’s Manual).

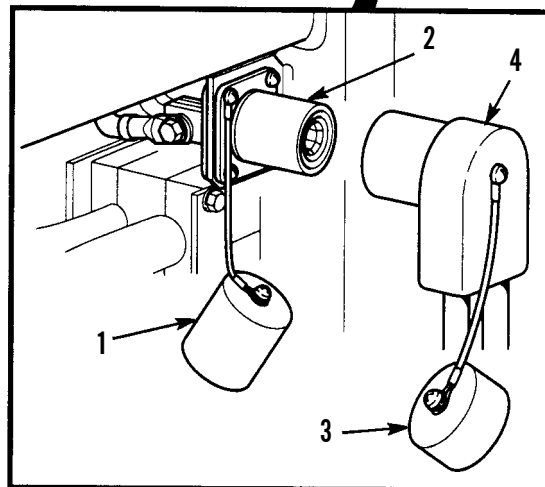
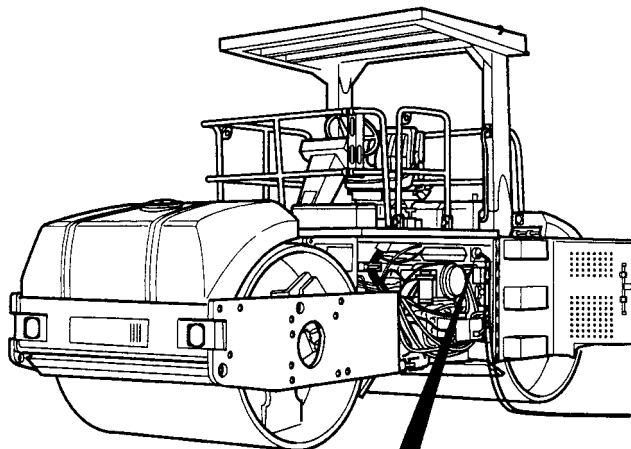

401-082

EMERGENCY PROCEDURES

NOTE

Emergency procedures for the CB534B and CB534C Rollers are the same. CB534B Roller is shown.

1. **Emergency Shutdown.**

- a. Stop roller by moving propel control lever (5) to NEUTRAL position.
- b. Turn engine start switch (6) fully counterclockwise. This will shut down power to all systems at once.

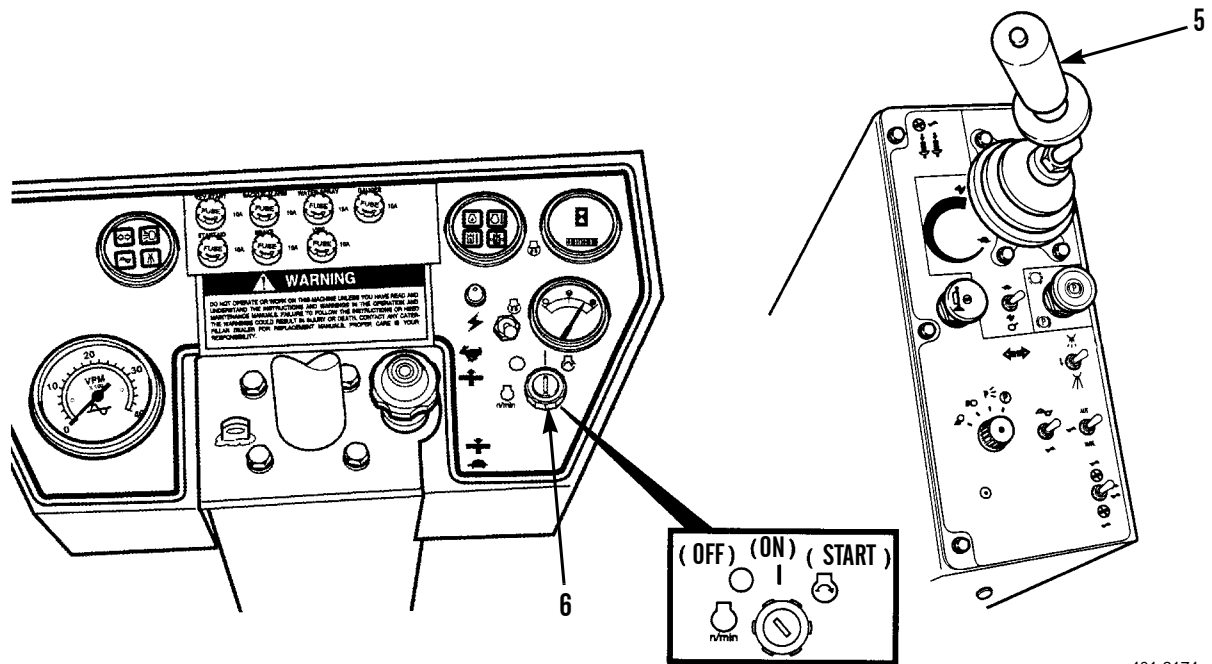

401-2174

EMERGENCY PROCEDURES - CONTINUED2. **Manual Release of Parking Brakes.****WARNING**

Ensure that roller is secured to prevent movement. Roller may freewheel when brakes are released. Ensure that path of roller travel is clear of personnel and equipment. Failure to follow this warning may result in injury or death.

NOTE

Roller brakes are automatically engaged when the propel control lever is in NEUTRAL position or engine is not running. Roller is equipped with a manual brake release pump to release brakes.

- a. Chock drums (WP 0005 00).
- b. Lift latch (7), push handle (8) toward front of roller (9) and open left-side door assembly (10).
- c. Unhook lanyard (11) from left-side door assembly (10) and hook lanyard to frame assembly (12).

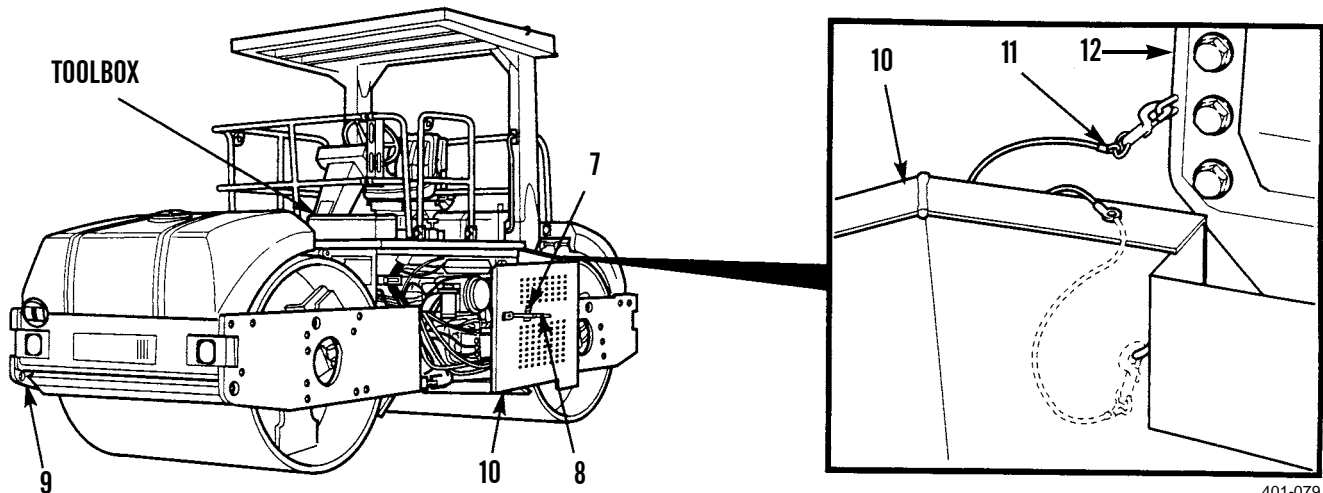

401-079

EMERGENCY PROCEDURES - CONTINUED**CAUTION**

Spring force must be relieved in propel system multifunction valve pressure limiters to prevent propel system damage.

NOTE

Brakes are locked in absence of hydraulic oil pressure. Manual brake release pump provides hydraulic oil pressure needed to release brakes.

- d. Remove 13 mm wrench, 4 mm socket head screw key and 5/64 in. socket head screw key (Table 2, Items 4, 11 and 12, WP 0027 00) from toolbox.
- e. Loosen nuts (13) and (14) using 13 mm wrench.
- f. Turn screws (15) and (16) clockwise (CW) using 4 mm socket head screw key, until stop is reached to relieve spring force on propel system multifunction valve pressure limiters.
- g. Using 13 mm wrench, tighten nuts (13) and (14).

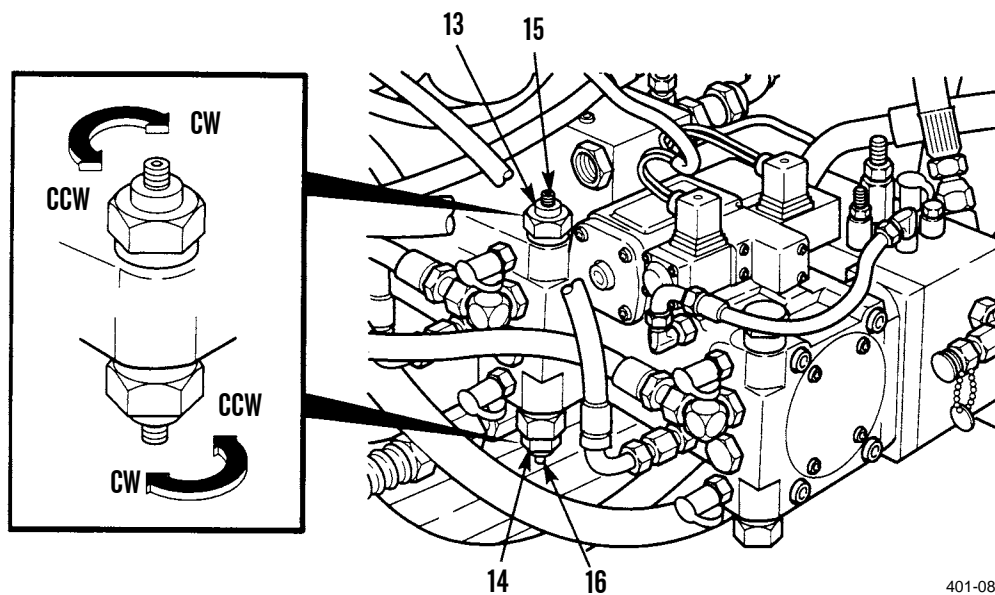

401-080

EMERGENCY PROCEDURES - CONTINUED

- h. Loosen setscrew (17) in knob (18) using 5/64 in. socket head screw key.
- i. Turn valve knob (18) clockwise to close valve (13).

NOTE

Push knob until resistance is felt (brakes are released).

- j. Push knob (20) of manual brake release pump (21) several times until brakes release.

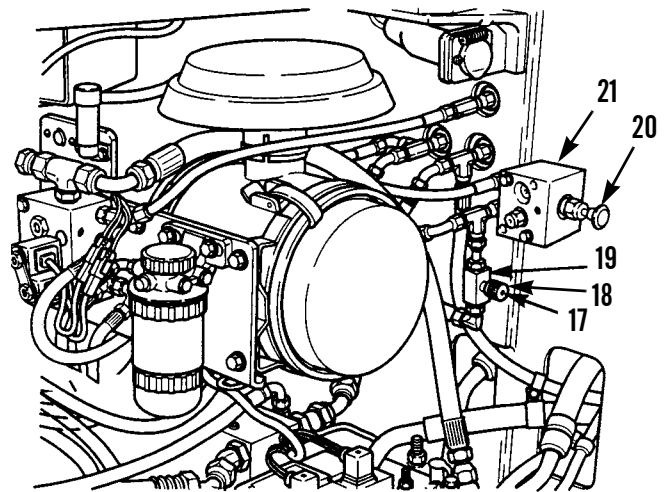

- k. Unhook lanyard (11) from frame assembly (12) and hook lanyard to left-side door assembly (10).
- l. Close left-side door assembly (10), push handle (8) into latch (7) and close latch.
- m. Stow 13 mm wrench, 5/64 in. socket head screw key and 4 mm socket head screw key in toolbox.

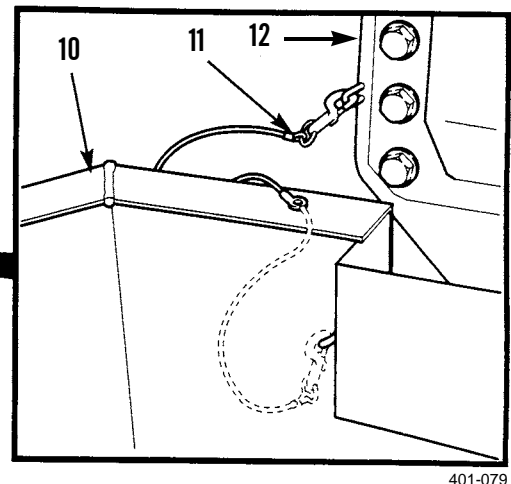
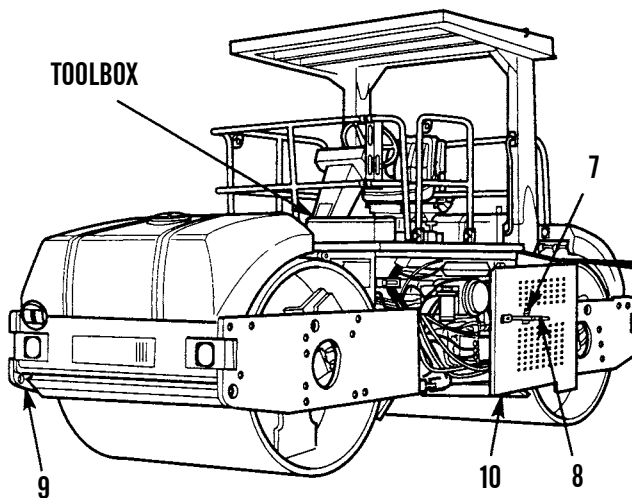

EMERGENCY PROCEDURES - CONTINUED3. **Reset Parking Brakes After Manual Release.****WARNING**

Ensure that roller is secured to prevent any movement. Roller may freewheel when brakes are released. Ensure that path of roller travel is clear of personnel and equipment. Failure to follow this warning may result in injury or death.

- a. Chock drums (WP 0005 00).
- b. Remove 13 mm wrench, 4 mm socket head screw key and 5/64 in. socket head screw key from toolbox (Table 2, Items 4, 11 and 12, WP 0027 00).
- c. Lift latch (7), push handle (8) toward front of roller (9) and open left-side door assembly (10).
- d. Unhook lanyard (11) from left-side door assembly (10) and hook lanyard to frame assembly (12).
- e. Turn valve knob (18) counterclockwise to fully open valve (19).
- f. Tighten setscrew (17) in valve knob (18) using 5/64 in. socket head screw key.
- g. Using 13 mm wrench, loosen nuts (13) and (14).
- h. Hold nuts (13) and (14) and turn screws (15) and (16) counterclockwise using 4 mm socket head screw key until stop is reached.
- i. Using 13 mm wrench, tighten nuts (13) and (14).
- j. Stow 13 mm wrench, 5/64 in. socket head screw key and 4 mm socket head screw key in toolbox.

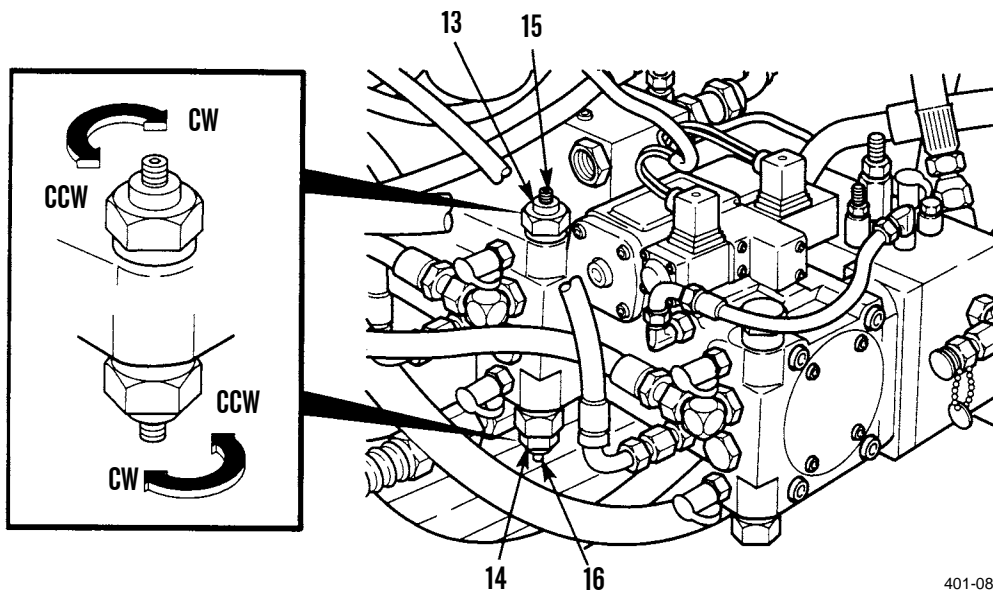

401-080

OPERATE IN EXTREME COLD**NOTE**

- By nature of its purpose, roller usually will not be operated in extremely cold temperatures. When roller is required to operate during temperatures below 32°F (0°C) observe the following procedures.
- Procedures for operating in extreme cold are the same for the CB534B and CB534C Rollers except where noted.

1. **Introduction.** Extreme cold causes many problems:
 - a. Lubricants thicken or congeal.
 - b. Batteries may freeze or lose their electrical efficiency.
 - c. Fuel may not readily atomize for combustion.
 - d. Various materials become hard, brittle, and easily damaged.
 - e. Cooling system requires adequate protection from extreme cold.
 - f. Fuels, lubricants, and antifreeze require special storage, handling, and use.

OPERATE IN EXTREME COLD - CONTINUED2. **Start Engine (CB534B).****WARNING**

DO NOT use ether starting fluids to start roller in extreme cold weather. The CB534B Roller is equipped with a water heater jacket. The use of ether could result in injury, or engine damage.

NOTE

The CB534B Roller is equipped with an engine block heating element which can be connected to an AC outlet when temperatures are below 32°F (0°C).

- a. If connected, remove 120Vac cable (extension cord) from coolant heater before starting engine.
 - (1) Open left door assembly (WP 0005 00).
 - (2) Lift latch (22) and remove 120Vac cable (extension cord) from coolant heater plug (23) and 120Vac outlet.
 - (3) Close left door assembly (WP 0005 00).
- b. Remove all ice and snow from machine as soon as possible.
- c. Prepare roller for operation in severe cold temperatures according to FM 9-207, FM 31-70 and FM 31-71 as necessary.
- d. Drain fuel filter and fuel/water separator (WP 0012 00) before filling fuel tank to prevent any water in fuel from freezing. This will also prevent fuel filter from clogging.
- e. Start engine (WP 0005 00) and allow engine to warm up for at least 15 minutes to reach normal operating temperature before beginning any operation.
- f. Watch fuel and warning lights closely. Stop roller, turn off engine (WP 0005 00). Refer to operator troubleshooting procedures (WP 0009 00 and WP 0010 00) when any unusual readings occur.

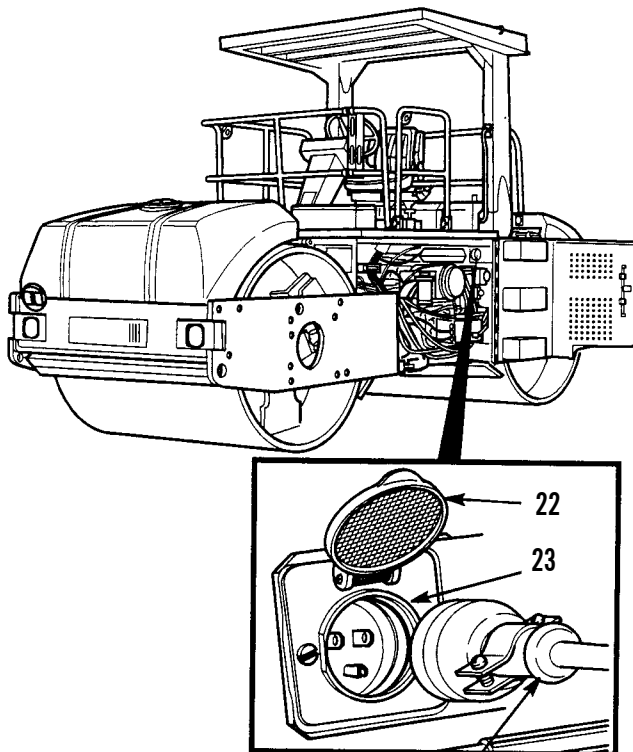

120Vac CABLE

401-077

OPERATE IN EXTREME COLD - CONTINUED

3. **Start Engine (CB534C).**

WARNING

DO NOT use ether starting fluids to start roller in extreme cold weather. The CB534C Roller is equipped with an inlet manifold heater. The use of ether could result in injury, or engine damage.

- a. Open right door assembly and turn battery disconnect switch to ON position (WP 0005 00).
- b. Push down parking brake knob (24) to apply parking brake.
- c. Move propel control lever (5) to NEUTRAL position.
- d. Push vibration push switch (25) to OFF position.
- e. Move water spray switch (26) to center position.

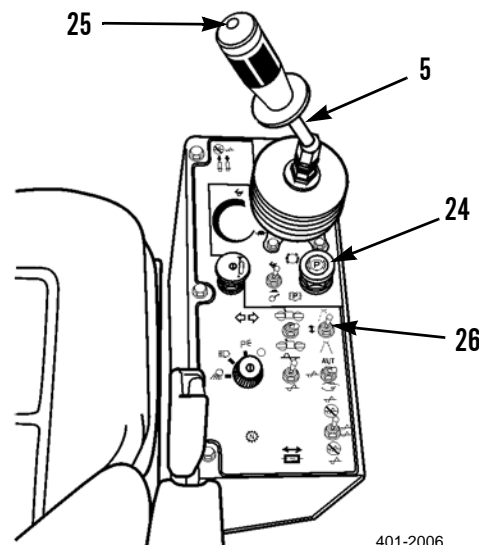

- f. Move throttle control switch (27) to FAST position.
- g. Turn engine start switch (6) to ON position.

NOTE

Do not press air inlet heater switch for more than 30 seconds without attempting to start engine. Allow inlet heater 60 seconds to cool down if engine is not cranked.

- h. Press and hold air inlet heater switch (28) for a minimum of 10 seconds and up to a maximum of 30 seconds, depending on outside air temperature.
- i. Turn engine start switch (6) to START position. When engine starts, release key.
- j. Disengage starter if engine does not start. Continue to press throttle control switch (27).

NOTE

Air inlet heater may be used after starting engine if engine is running rough.

- k. Repeat step i after 10 seconds.
- l. When engine starts, continue to press and hold air inlet heater switch (28) until engine runs smoothly.
- m. Move throttle control switch (27) to SLOW position after engine starts.

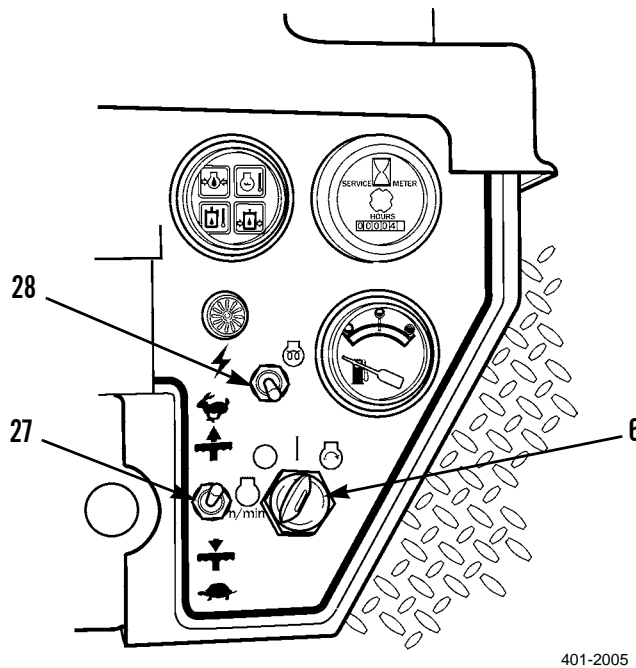

OPERATE IN EXTREME HEAT**CAUTION**

- Operating during periods of extreme heat [ambient temperatures above 100°F (38°C)] can cause engine and hydraulic systems to overheat. Engine temperatures above 230°F (110°C) and hydraulic oil temperatures above 250°F (121°C) can cause damage to engine and hydraulic system components. Check engine coolant temperature warning light and hydraulic oil temperature warning light often during periods of extreme heat to prevent damage to engine and hydraulic system.
 - Gaskets and seals are more likely to leak when engine and hydraulic system operating temperatures are high. Check engine and hydraulic oil levels more often during periods of extreme heat to prevent damage to engine and hydraulic system components. Check for leaks around gaskets, seals and fittings more often.
1. Check engine oil level (WP 0014 00) and monitor engine coolant temperature warning light.
 2. Check hydraulic oil level (WP 0018 00) and monitor hydraulic oil temperature warning light.
 3. Check cooling system often:
 - a. If engine coolant temperature or hydraulic oil temperature warning lights illuminate, stop roller and allow engine to run at idle for a few minutes to cool down.
 - b. When warning lights have gone out, resume operation as necessary.
 4. Clean and lubricate roller with correct grade of lubricants to help prevent deterioration. Have Field Maintenance change air, fuel, transmission and hydraulic filter elements at shorter than normal intervals, as designated in Field Maintenance PMCS.
 5. Perform operator PMCS more often than normal (WP 0011 and WP 0012 00).
 6. Do not fill fuel tank completely. Extreme heat causes fuel to expand and overflow.
 7. Ensure that water is as free as possible of mineral deposits before adding coolant mixture to radiator. Local desert water sources have high mineral deposits that will clog radiator.
 8. Ensure that water/antifreeze mixture is 50/50. This mixture raises coolant boiling point to help prevent overheating.
 9. High temperatures can damage hoses. Check radiator, fuel and lubricant hoses for leaks around fittings. Notify supervisor if hoses are damaged.
 10. Park roller under cover or in the shade, if possible.

OPERATE IN SANDY OR DUSTY CONDITIONS**NOTE**

The roller normally operates in dusty conditions and PMCS instructions are designed to handle these conditions. However, in deserts, dust conditions are more extreme and certain checks and services are required more often than normal.

1. Check engine coolant temperature and engine oil pressure frequently.
2. Check air restriction indicator more often to ensure air cleaner is not becoming clogged.
3. Keep radiator core free of dust, leaves, and any other obstructions to air circulation.

OPERATION UNDER UNUSUAL CONDITIONS - CONTINUED

0006 00

OPERATE IN SANDY OR DUSTY CONDITIONS - CONTINUED

4. Check and drain fuel/water separator (WP 0016 00).
5. Closely monitor all gauges and warning lights to ensure machine is not affected by dusty conditions.
6. Park roller in sheltered area out of wind. If a sheltered area is not available, park roller facing into wind to prevent sand or dust from blowing into radiator.
7. Cover instrument panel (with vandal guard down), air restriction indicator, hydraulic oil level indicator, fuel tank fill cap, hydraulic oil tank fill cap and work lights when machine is parked for extended periods of time in extremely dusty conditions.
8. Cover exhaust outlet to prevent dust from blowing into exhaust system.
9. Cover open space in fuel tank fill hole when adding fuel to fuel tank.
10. Clean spouts of fuel containers and areas around filler caps on fuel tank before adding fuel. Under extremely sandy or dusty conditions, filter fuel when filling tank.
11. Ensure engine and transmission oil filler tubes are cleaned before gage rods are removed to check fluid levels. Clean accumulations of sand and dirt from around any fluid filler location before checking or adding fluids.

FORDING**CAUTION**

DO NOT enter water deeper than 10 in. (25 cm). Fording in water depth greater than 10 in. (25 cm) can cause damage to equipment.

1. Test depth of water and ensure firmness and consistency of bottom surface. Do NOT attempt to ford if depth exceeds 10 in. (25 cm).
2. Ensure all gauges are indicating normal operating pressure and temperature.
3. Stop roller at edge of water.
4. Enter water slowly.
5. After fording, wash roller and wipe clean and dry.
6. Perform lubrication services as soon as possible, with assistance from Field Maintenance.

NUCLEAR, BIOLOGICAL AND CHEMICAL (NBC) DECONTAMINATION PROCEDURES

The decontamination kit bracket is mounted on the rear of the roller. Refer to TM 3-4320-214-12&P for operation of the decontamination kit.

END OF WORK PACKAGE

INTRODUCTION

1. This work package shows the location for stowage of equipment and materials required to be carried on the Roller, Motorized, Vibrating Tandem Steel Drums.
2. This work package also includes illustrations showing the location of all decals, data plates, and stencils on the Roller.
3. Decal and data plates are the same for the CB534B and CB534C Rollers except where noted. CB534B Roller is shown.

STOWAGE GUIDE

1. The equipment stowage locator is designed to help inventory items required for safe and efficient operation.
2. The equipment locator is representative of BII and applicable AAL stowage on the roller. Refer to WP 0027 00 for a listing of BII and AAL items.

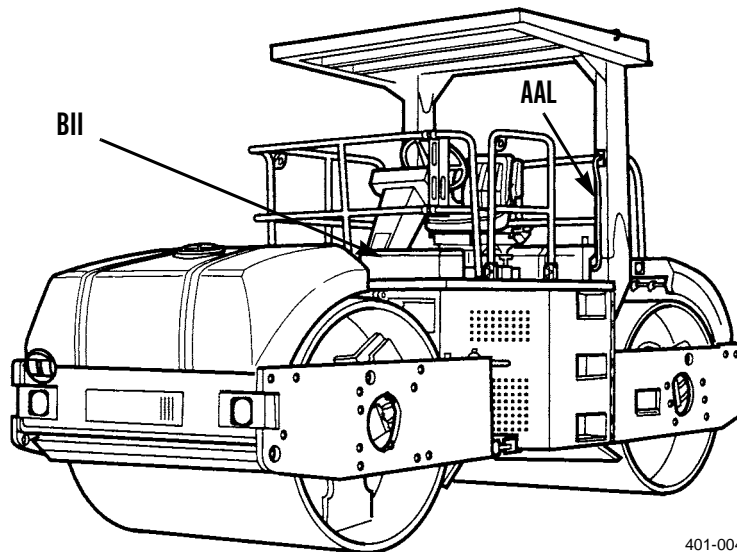

401-004

DECALS, DATA PLATES, AND STENCILS

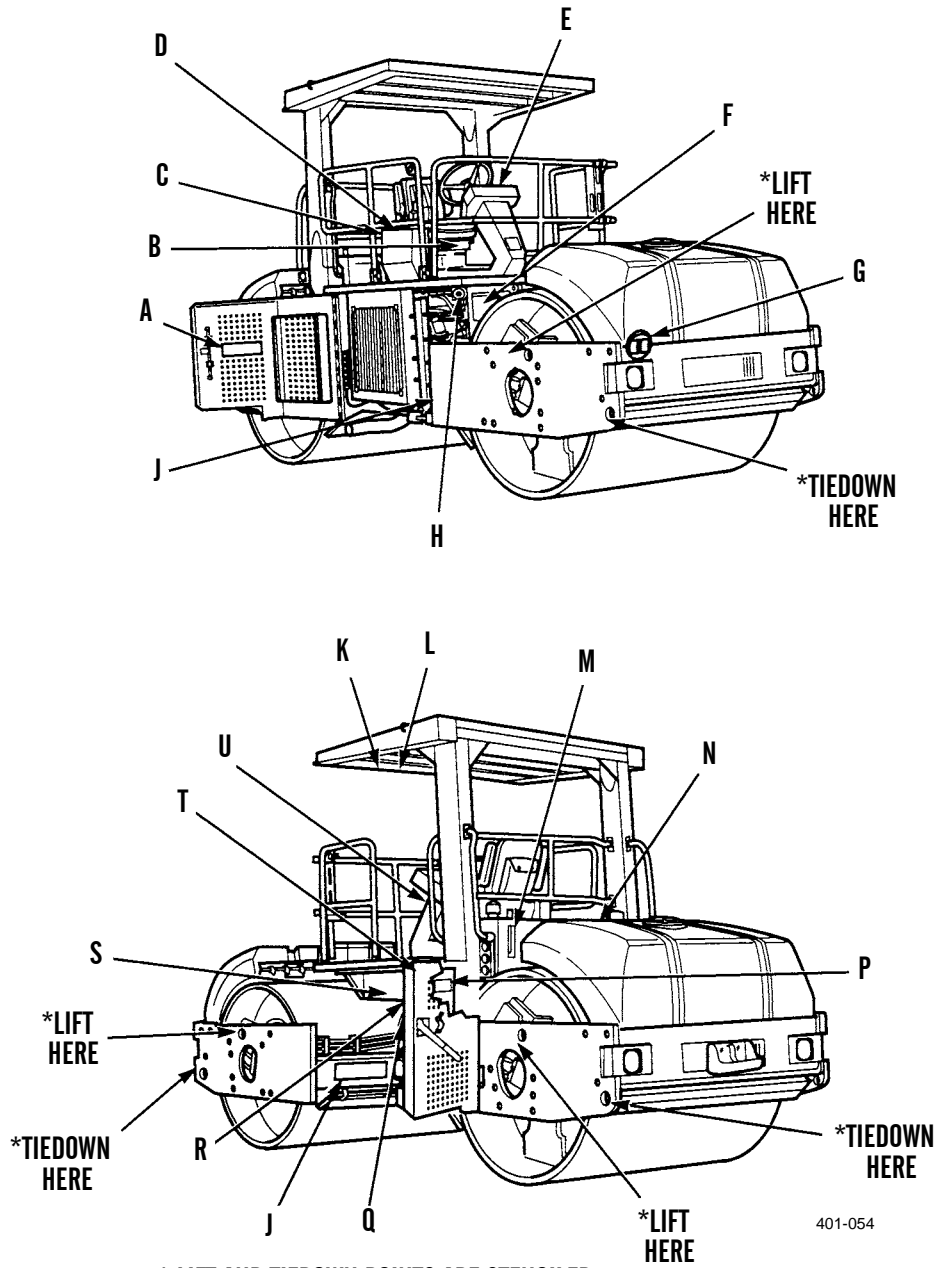

* LIFT AND TIEDOWN POINTS ARE STENCILED ON THE MACHINE AT APPROPRIATE LOCATIONS

DECALS, DATA PLATES, AND STENCILS - CONTINUED

A
CB534B

WARNING

LUBRICATION, MAINTENANCE, OR REPAIR OF THIS MACHINE CAN BE DANGEROUS UNLESS PERFORMED PROPERLY. EACH PERSON MUST SATISFY HIMSELF THAT HE HAS THE NECESSARY SKILL & INFORMATION, PROPER TOOLS, & EQUIPMENT, AND THAT HIS WORK METHOD IS SAFE & CORRECT. CATERPILLAR DEALERS ARE AVAILABLE TO PROVIDE SERVICE AND INFORMATION.

ITEM IDENTIFICATION	SERVICE	SERVICE
1. WALKING INSPECTION	EVERY 10 SERVICE HOURS OR DAILY	INSPECT MACHINE
2. ENGINE OIL (1)	CHECK OIL LEVEL	CHECK OIL LEVEL
3. HYDRAULIC OIL (2)	CHECK COOLANT LEVEL	CHECK COOLANT LEVEL
4. FUEL SYSTEM	INSPECT	INSPECT
5. START RELAY	TEST	TEST
6. INDICATORS & GAUGES	TEST	TEST
7. BACKUP ALARM	CLEAN FILTER	CLEAN FILTER
8. FRONT WATER SYSTEM	CLEAN PUMP	CLEAN PUMP
9. REAR WATER SYSTEM	SHRAN	SHRAN
10. MIDDLE START SWITCH	CHECK OPERATION	CHECK OPERATION
11. FRONT WATER STRAINERS	CHECK CLEAN	CHECK CLEAN
12. REAR WATER STRAINERS	CLEAN	CLEAN
13. FRONT RING BEARINGS (MPOAM)	EVERY 50 SERVICE HOURS OR WEEKLY	LUBRICATE
14. REAR RING BEARINGS (MPOAM)		LUBRICATE
15. REAR VIBRATOR HOUSING	CHECK OIL LEVEL	CHECK OIL LEVEL
16. FRONT VIBRATOR HOUSING	CHECK OIL LEVEL	CHECK OIL LEVEL
17. FRONT PROPELLER GEARBOX	CHECK OIL LEVEL	CHECK OIL LEVEL
18. REAR PROPELLER GEARBOX	CHECK OIL LEVEL	CHECK OIL LEVEL
19. ENGINE OIL (2)	EVERY 250 SERVICE HOURS OR 3 MONTHS	CHANGE OIL AND FILTER
20. THE SLUITH CONTAIN IN THE SIGHT GLASS		CHANGE OIL AND FILTER
21. AND REDUCE THE OIL CHANGE INTERVAL BY 1/2		CHANGE OIL AND FILTER
22. HYDRAULIC OIL SYSTEM	ADJUST ON NEW OR RECONDITIONED	ADJUST ON NEW OR RECONDITIONED
23. ENGINE VALVE LASH / IDLE SPEED	ADJUST	ADJUST
24. PAN & ALTERNATOR BELTS	INSPECT & ADJUST	INSPECT & ADJUST
25. OPERATORS STATION SWAY LEVER (MPOAM)	LUBRICATE	LUBRICATE
26. ARTICULATION BEARINGS (MPOAM)	LUBRICATE	LUBRICATE

COMPARTMENT OR SYSTEM	LITERS	GALLONS
COOLING SYSTEM	24	6.3
ENGINE CHAMBER & PUMP	208	55
HYDRAULIC PUMP	15	4
VIBRATOR HOUSING	12	3.1
WATER SYSTEM	500	132
REAR WATER SYSTEM	70	18.4

ITEM	IDENTIFICATION	SERVICE
1	STEERING CYLINDER (MPOAM)	LUBRICATE
2	FRONT PROPELLER GEARBOX	CHANGE OIL**
3	REAR PROPELLER GEARBOX	CHANGE OIL**
4	FUEL SYSTEM	EVERY 500 SERVICE HOURS OR 6 MONTHS
5	COOLING SYSTEM	CHANGE FILTER & WATER SEP. ELEMENT AND ADDITIVE
6	FUEL PUMP CAP & PUL. SCREEN	CLEAN & REPLACE
7	FRONT VIBRATOR HOUSING OIL	EVERY 1000 SERVICE HOURS OR 12 MONTHS
8	REAR VIBRATOR HOUSING OIL	EVERY 1000 SERVICE HOURS OR 12 MONTHS
9	HOLLOW PROTECTIVE SPLICING HOUSING	CHANGE SYNTHETIC OIL
10	HYDRAULIC SYSTEM (MPOAM)	CHANGE OIL
11	FRONT PROPELLER GEARBOX	CHANGE OIL**
12	REAR PROPELLER GEARBOX	CHANGE OIL**
13	BATTERIES	ASPECT & INSPECT ELECTROLYTE LEVEL
14	ENGINE AIR INLET SYSTEM	SERVICE FILTER
15	BACKUP	SHRAN
16	WATER SEPARATION SYSTEM	SHRAN
17	WATER PUMP	SHRAN
18	ENGINE VALVE LASH	ADJUST
19	ENGINE CHAMBER & RADIATOR SYSTEM	ADJUST
20	OPERATORS PLATFORM	LUBRICATE FITTINGS
21	COOLING SYSTEM COOLANT	CHANGE
22	WATER SYSTEM	SHRAN AND CLEAN

ITEM	IDENTIFICATION	SERVICE
1	HYDRAULIC OIL	TEMPERATURE RANGE ABOVE 25 F ABOVE 25 F
2	MIL-G-10520	ABOVE 32 F 15W40
3	MIL-G-2104F	0 F TO 32 F 10W
4	MIL-G-46167	25 F TO 0 F
5	MIL-G-46167	0 F TO -25 F
6	MIL-PRF-2105E	-25 F TO 0 F 75W
7	MIL-PRF-2105E	ABOVE 0 F 60W90

REFILL (3) (4) (5) (6) (7) (8) (9) (10) (11) (12) (13) (14) (15) (16) (17) (18) (19) (20) (21) (22)

124-1368-03

DECALS, DATA PLATES, AND STENCILS - CONTINUED

A
CB534C

WARNING

LUBRICATION, MAINTENANCE, OR REPAIR OF THIS MACHINE CAN BE DANGEROUS UNLESS PERFORMED PROPERLY. EACH PERSON MUST SATISFY HIMSELF THAT HE HAS THE NECESSARY SKILL & INFORMATION, PROPER TOOLS & EQUIPMENT, AND THAT HIS WORK METHOD IS SAFE & CORRECT. CATERPILLAR DEALERS ARE AVAILABLE TO PROVIDE SERVICE AND INFORMATION.

CB534C VIBRATORY COMPACTOR LUBRICATION

ITEM IDENTIFICATION	SERVICE	SERVICE
EVERY 10 SERVICE HOURS OR DAILY	INSPECT MACHINE	LUBRICATE
1. MOUNTING BRACKET	CHEK LEVEL	CHANGE OIL **
2. ENGINE OIL (E.O.)	CHEK OIL LEVEL	CHANGE OIL **
3. HYDRAULIC OIL (H.O.)	CHEK OIL LEVEL	EVERY 500 SERVICE HOURS OR 6 MONTHS *
4. COOLING SYSTEM	INSPECT	CHANGE FILTER & WATER DEP. ELEMENT
5. BEAT BELT	TEST	ADD ADJUSTIVE
6. INDICATORS & GAUGES	TEST	CLEAN STRAINER
7. BACKUP ALARM	TEST	CLEAN STRAINER
8. FRONT WATER SYSTEM	CLEAN FILTER	EVERY 1000 SERVICE HOURS OR 12 MONTHS *
9. REAR WATER SYSTEM	CLEAN FILTER	CHANGE SYNTHETIC OIL
10. WATER REPARATOR	DRAIN	CHANGE SYNTHETIC OIL
11. MULTIPLE START SWITCH	CHEK OPERATION	CHANGE OIL
12. FRONT WATER STRAINERS	CHEK/CLEAN	HYDRAULIC SYSTEM (H.O.)
13. REAR WATER STRAINERS	CHEK/CLEAN	HYDRAULIC SYSTEM
14. FRONT/REAR WATER SPRAY NOZZLES	CLEAN	FRONT PROPELL. BEARING
15. FRONT IDLE BEARINGS (FIBER)	LUBRICATE	REAR PROPELL. BEARING
16. REAR IDLE BEARINGS (FIBER)	LUBRICATE	CHARGE OIL **
17. FRONT VIBRATOR HULLING	CHEK OIL LEVEL	CHARGE OIL **
18. REAR VIBRATOR HULLING	CHEK OIL LEVEL	INSPECT & CHECK ELECTROLYTE LEVEL
19. FRONT PROPELL. BEARING	CHEK OIL LEVEL	EVERY 1000 SERVICE HOURS OR WHEN READ
20. REAR PROPELL. BEARING	CHEK OIL LEVEL	SERVICE FILTER
EVERY 250 SERVICE HOURS OR 3 MONTHS *		REPLACE CAP. CLEAN CORE
1. ENGINE OIL (E.O.)	CHANGE OIL AND FILTER	DRAIN
2. IF THE SPLITTER CONTAINS IN THE FUEL IS GREATER THAN 1.5% BY WEIGHT USE AN OIL WITH A T.M. OF 30 AND REPLACE THE OIL CHANGE INTERVAL BY 1/2		DRAIN WATER AND SEDIMENT
3. HYDRAULIC OIL SYSTEM	CHANGE FILTER **	EVERY 2000 SERVICE HOURS OR 12 MONTHS *
4. ENGINE VALVE LASH/VALVE SPEED	ADJUST ON NEW OR RECONDITIONED **	DRAIN
5. FAN & ALTERNATOR BELTS	INSPECT/ADJUST	DRAIN AND CLEAN
6. OPERATOR'S SEATING SEVERAL LEVELS (HORN)	LUBRICATE	
7. ARTICULATION BEARINGS (HORN)	LUBRICATE	
8. OPERATOR'S SEATING SEVERAL LEVELS (HORN)	LUBRICATE	
9. ARTICULATION BEARINGS (HORN)	LUBRICATE	
10. CHARGING SYSTEM	U.S. BATTERY	
11. FUEL TANK	7.6	
12. HYDRAULIC TANK	8	
13. WATER SYSTEM	11	
14. FRONT VIBRATOR HULLING	12	
15. REAR VIBRATOR HULLING	13	
16. BEAT BELT	14	
17. BEAT BELT	15	
18. BEAT BELT	16	
19. BEAT BELT	17	
20. BEAT BELT	18	
21. BEAT BELT	19	
22. BEAT BELT	20	

ITEM	LUBRICANT	TEMPERATURE RANGE
1. FRONT PROPELL. BEARING	KIL-4-44147	ABOVE -20°F
2. REAR PROPELL. BEARING	KIL-4-44147	ABOVE -20°F
3. FRONT VIBRATOR HULLING	KIL-4-44147	ABOVE -20°F TO 150°F
4. REAR VIBRATOR HULLING	KIL-4-44147	ABOVE -20°F TO 150°F
5. FRONT/REAR WATER SPRAY NOZZLES	KIL-4-44147	ABOVE -20°F TO 150°F
6. FRONT/REAR WATER STRAINERS	KIL-4-44147	ABOVE -20°F TO 150°F
7. FRONT/REAR WATER STRAINERS	KIL-4-44147	ABOVE -20°F TO 150°F
8. FRONT/REAR WATER STRAINERS	KIL-4-44147	ABOVE -20°F TO 150°F
9. FRONT/REAR WATER STRAINERS	KIL-4-44147	ABOVE -20°F TO 150°F
10. FRONT/REAR WATER STRAINERS	KIL-4-44147	ABOVE -20°F TO 150°F
11. FRONT/REAR WATER STRAINERS	KIL-4-44147	ABOVE -20°F TO 150°F
12. FRONT/REAR WATER STRAINERS	KIL-4-44147	ABOVE -20°F TO 150°F
13. FRONT/REAR WATER STRAINERS	KIL-4-44147	ABOVE -20°F TO 150°F
14. FRONT/REAR WATER STRAINERS	KIL-4-44147	ABOVE -20°F TO 150°F
15. FRONT/REAR WATER STRAINERS	KIL-4-44147	ABOVE -20°F TO 150°F
16. FRONT/REAR WATER STRAINERS	KIL-4-44147	ABOVE -20°F TO 150°F
17. FRONT/REAR WATER STRAINERS	KIL-4-44147	ABOVE -20°F TO 150°F
18. FRONT/REAR WATER STRAINERS	KIL-4-44147	ABOVE -20°F TO 150°F
19. FRONT/REAR WATER STRAINERS	KIL-4-44147	ABOVE -20°F TO 150°F
20. FRONT/REAR WATER STRAINERS	KIL-4-44147	ABOVE -20°F TO 150°F
21. FRONT/REAR WATER STRAINERS	KIL-4-44147	ABOVE -20°F TO 150°F
22. FRONT/REAR WATER STRAINERS	KIL-4-44147	ABOVE -20°F TO 150°F

226-1103-00

DECALS, DATA PLATES, AND STENCILS - CONTINUED

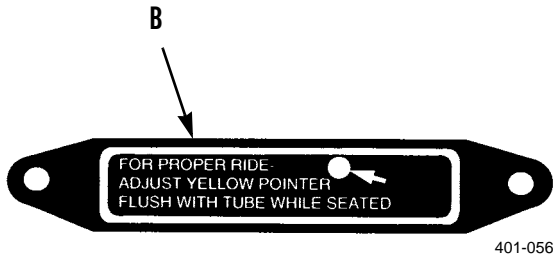

401-056

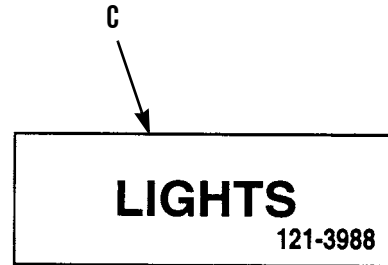

401-057

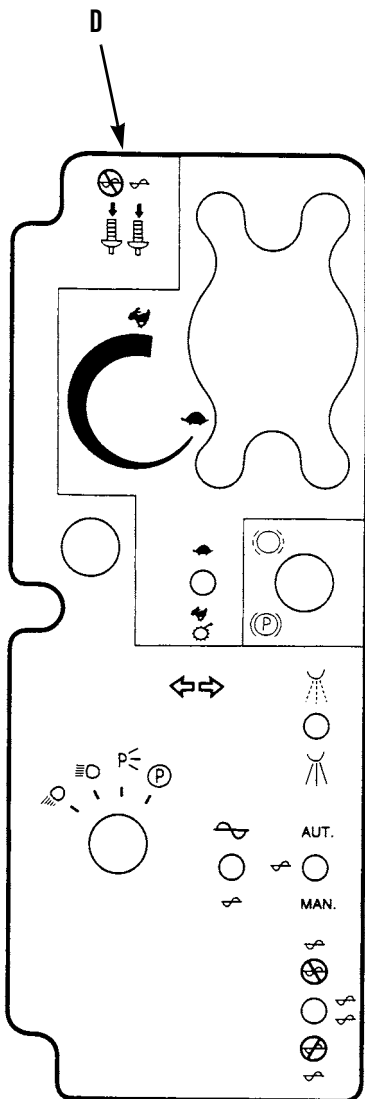

CB534B

401-058

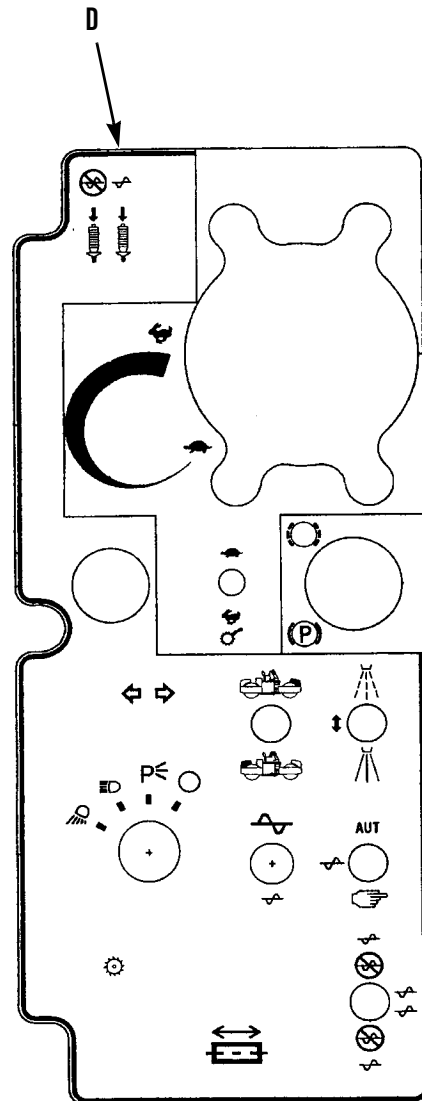

CB534C

401-2042

DECALS, DATA PLATES, AND STENCILS - CONTINUED

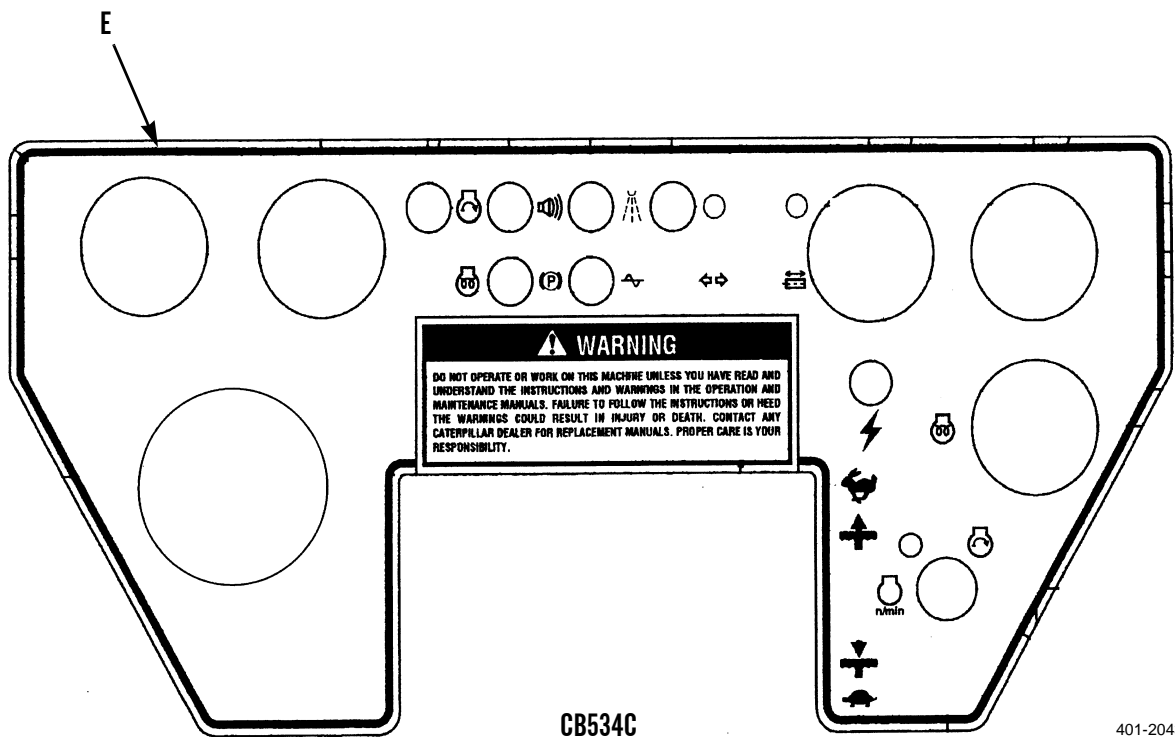
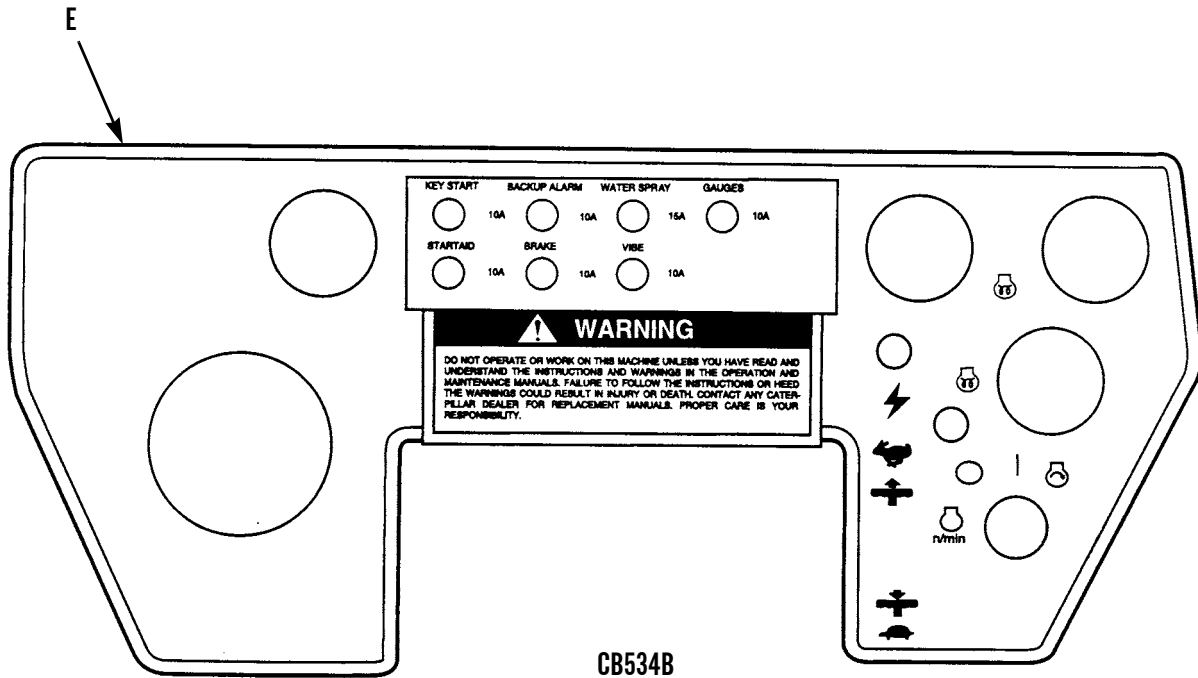

401-2043

DECALS, DATA PLATES, AND STENCILS - CONTINUED

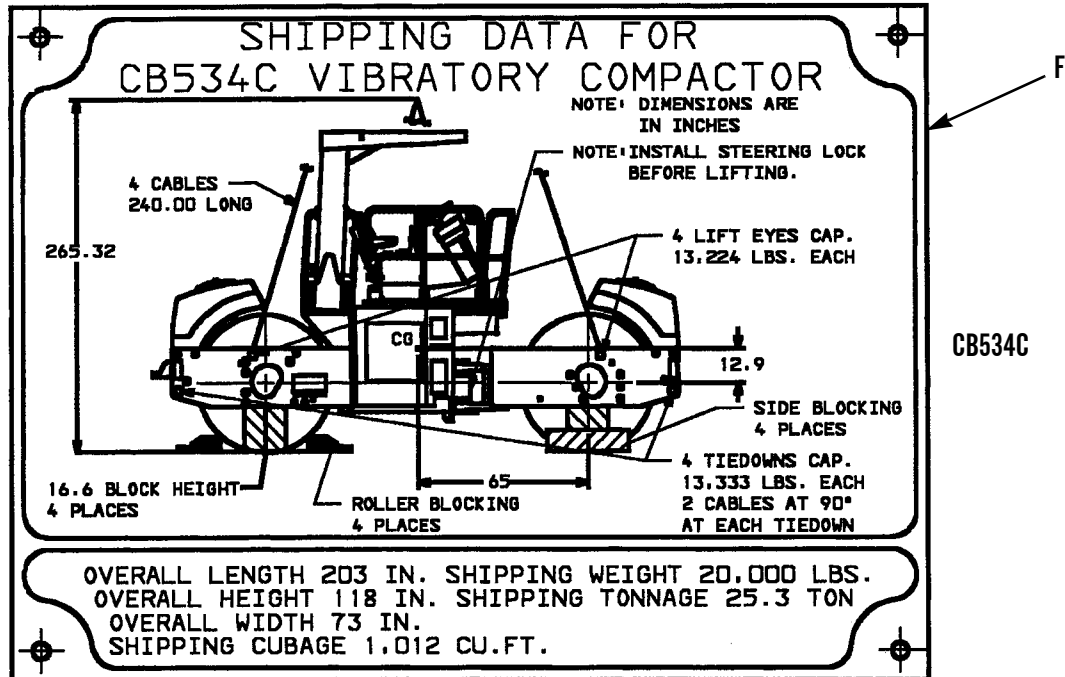
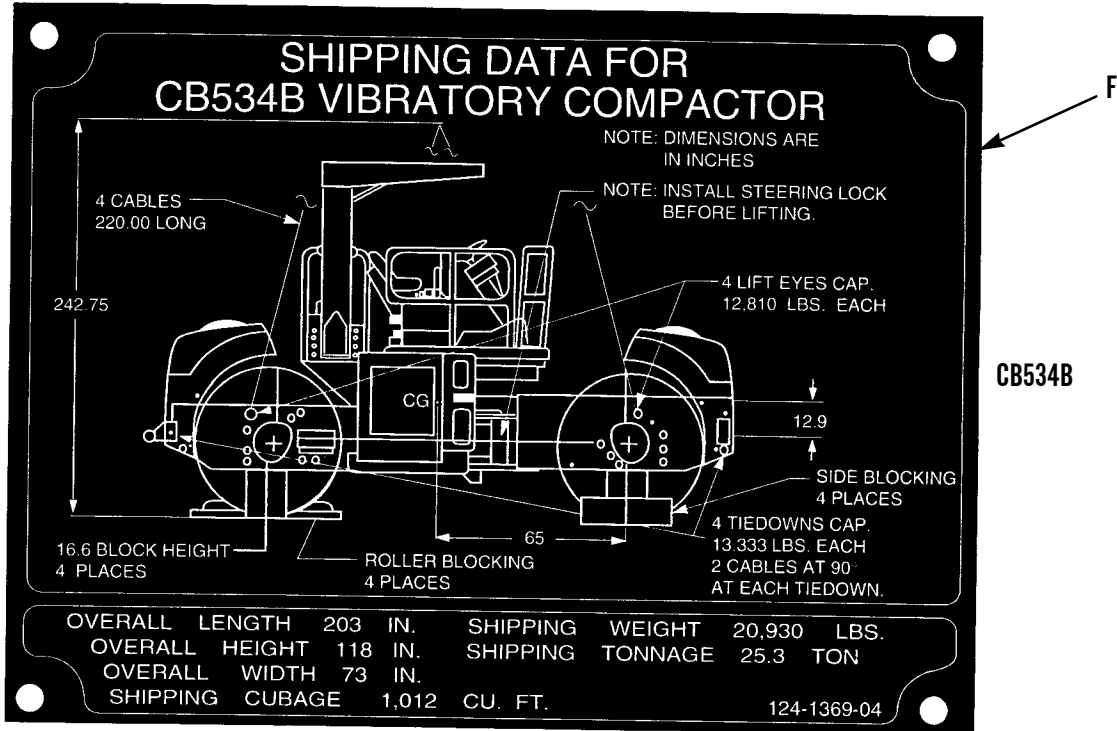

DECALS, DATA PLATES, AND STENCILS - CONTINUED

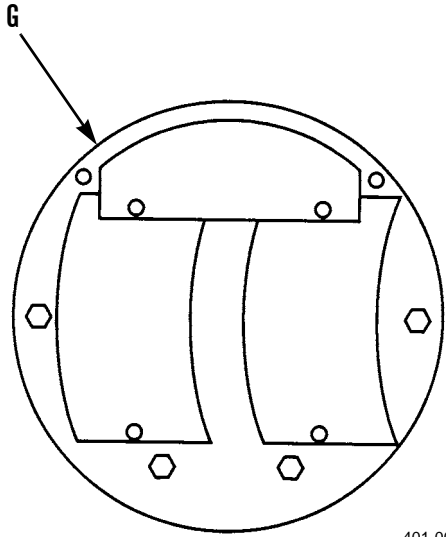

401-061

401-063

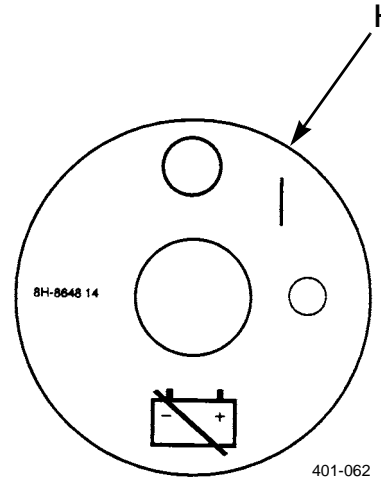

401-062

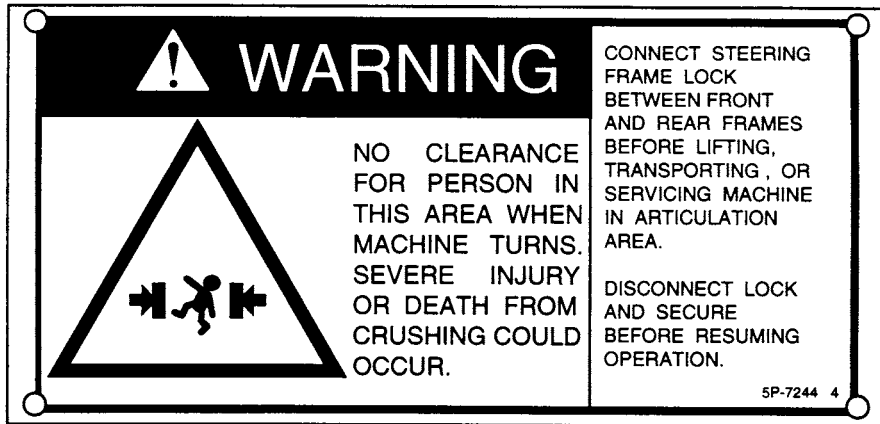

401-063



401-2182

DECALS, DATA PLATES, AND STENCILS - CONTINUED

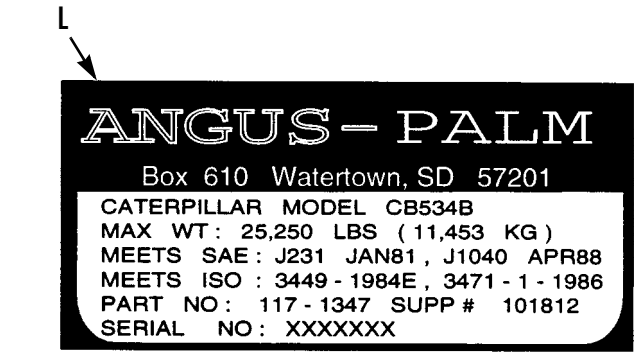

CB534B ONLY

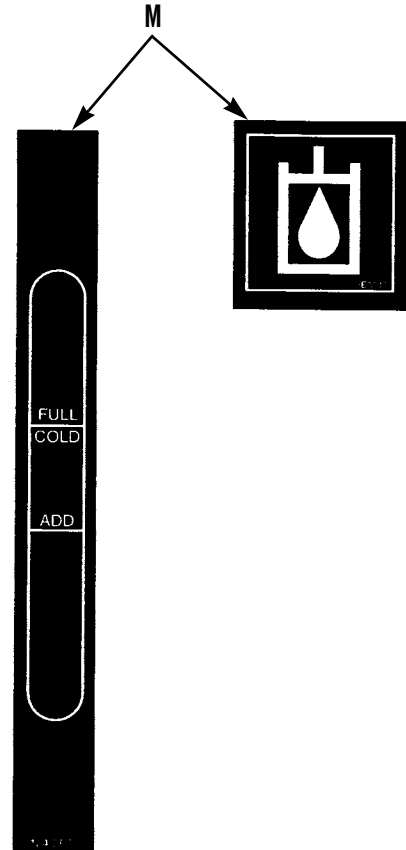

DECALS, DATA PLATES, AND STENCILS - CONTINUED

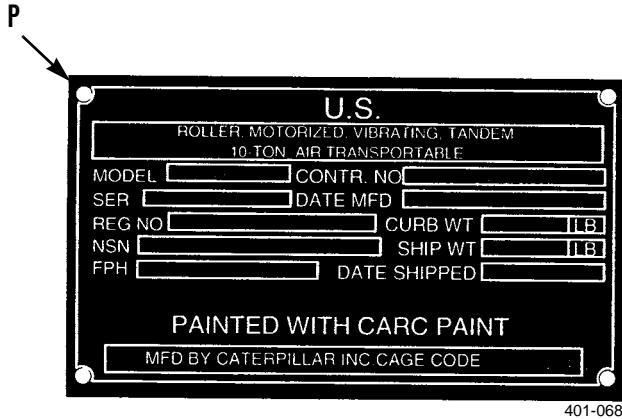

401-068



401-2188

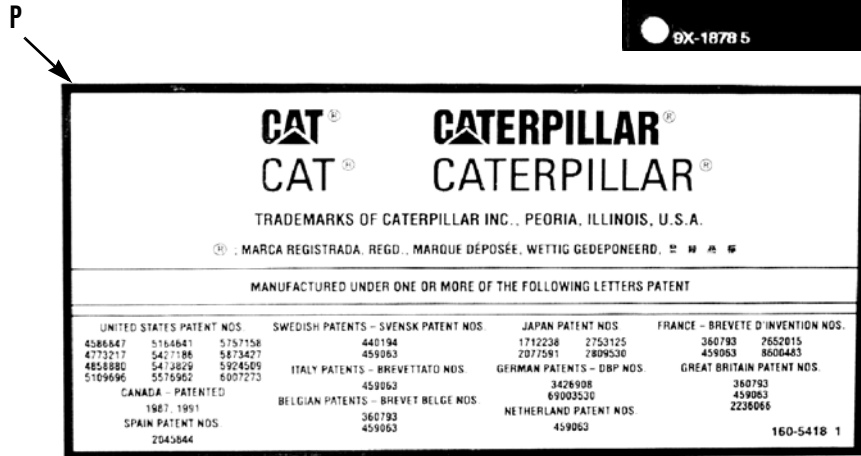

401-2189



401-069

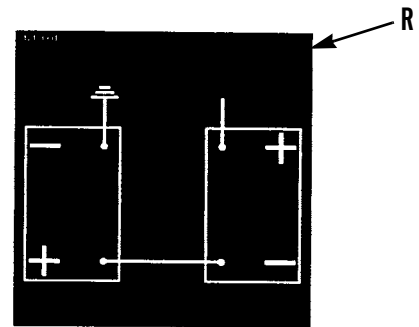

401-070

LOCATED ON UNDERSIDE OF OPERATOR PLATFORM

DECALS, DATA PLATES, AND STENCILS - CONTINUED



401-071



401-072

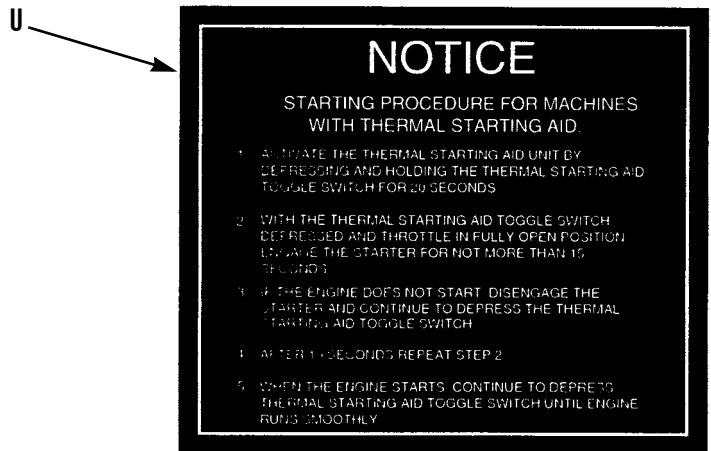

401-073

END OF WORK PACKAGE

CHAPTER 3
OPERATOR TROUBLESHOOTING

GENERAL

1. This chapter provides information for identifying and correcting malfunctions which may develop while operating the CB534B and CB534C Rollers, Motorized, Vibrating Tandem Steel Drums. Troubleshooting procedures for CB534B and CB534C Rollers are the same except where noted.
2. The Troubleshooting Symptom Index in WP 0009 00 lists common malfunctions which may occur and refers you to the proper page in WP 0010 00 for a troubleshooting procedure.
3. If you are unsure of the location of an item mentioned in troubleshooting, refer to WP 0002 00 or WP 0004 00.
4. Before performing troubleshooting, read and follow all safety instructions found in the Warning Summary at the front of this manual.
5. The Troubleshooting Symptom Index cannot list all malfunctions that may occur, nor all tests or inspections and corrective actions. If a malfunction is not listed, or is not corrected by the listed corrective actions, notify supervisor.
6. When troubleshooting a malfunction:
 - a. Locate the symptom or symptoms in WP 0009 00 that best describe the malfunction.
 - b. Turn to the page in WP 0010 00 where the troubleshooting procedures for the malfunction in question are described. Headings at the top of each page show how each troubleshooting procedure is organized: MALFUNCTION, TEST OR INSPECTION (in step number order), and CORRECTIVE ACTION.
 - c. Perform each step in the order listed until the malfunction is corrected. DO NOT perform any maintenance task unless the troubleshooting procedure tells you to do so.

EXPLANATION OF COLUMNS

The columns in Table 1 in WP 0010 00 are defined as follows:

1. **MALFUNCTION**. A visual or operational indication that something is wrong with the equipment.
2. **TEST OR INSPECTION**. A procedure to isolate the problem in a system or component.
3. **CORRECTIVE ACTION**. A procedure to correct the problem.

END OF WORK PACKAGE

Malfunction/Symptom

Troubleshooting Procedure Page

ELECTRICAL SYSTEM

Alternator Indicator is On 0010 00-30

Backup Alarm Does Not Work 0010 00-30

Fuel Gauge Does Not Operate 0010 00-32

Horn Does Not Operate 0010 00-31

No Power to Accessories With Engine Running 0010 00-32

Starter Does Not Turn or Turns Slowly 0010 00-29

Starter Turns But Does Not Crank Engine 0010 00-29

Starting Aid Switch Does Not Work (CB534B Roller Only) 0010 00-30

Roller Has No Electrical Power 0010 00-27

Vibrations Per Minute (VPM) Gauge Does Not Operate 0010 00-32

Warning and Indicator Lights Do Not Operate 0010 00-30

Work Lights and Gauge Lights Do Not Operate 0010 00-31

ENGINE

Engine Cranks But Will Not Start or is Hard to Start 0010 00-1

Engine Exhaust Smokes Excessively (Too Much Black or Gray Smoke) 0010 00-14

Engine is Sluggish 0010 00-10

Engine is Unusually Noisy 0010 00-20

Engine is Using More Fuel Than Usual 0010 00-21

Engine Misfires or Idles Rough 0010 00-16

Engine Oil Pressure is Low (Warning Light and Warning Horn On) 0010 00-19

Engine Operating Temperature is Too High (Warning Light and Warning Horn On) 0010 00-23

Engine Starts But Will Not Keep Running 0010 00-6

Engine Surges (Speed Changes) 0010 00-20

Engine Will Not Stop Running 0010 00-27

HYDRAULIC SYSTEM

Hydraulic Oil Temperature is High (Warning Light and Warning Horn On) 0010 00-33

Hydraulic Oil Pressure is Low (Warning Light and Warning Horn On) 0010 00-34

STEERING

Power Steering Pump Makes Noise and Steering Cylinder Rods Do Not Move Smoothly 0010 00-34

Roller Does Not Turn When Steering Wheel is Turned 0010 00-35

Roller Turns Slowly in Both Directions 0010 00-35

Too Much Force is Needed to Turn Steering Wheel 0010 00-35

Malfunction/Symptom

Troubleshooting Procedure Page

PROPEL SYSTEM

Propel System Does Not Change Speeds When Propel Speed Switch is Moved 0010 00-36
 Propel System Engages Very Slowly When Making a Shift 0010 00-36
 Roller Will Not Move When Propel Control Lever is Operated 0010 00-35

VIBRATORY SYSTEM

Vibration Frequency Start-up is Slow, Time Lag After Travel Starts is Excessive 0010 00-37
 Vibration Mechanism is Noisy 0010 00-37
 Vibration Occurs in Only One Drum 0010 00-38
 Vibratory System Will Not Work Forward and Reverse Travel 0010 00-37

WATER SPRAY SYSTEM

Nozzle Spray Pattern is Inconsistent 0010 00-43
 Spray Does Not Occur On Either Drum When Water Spray Switch is in Continuous Spray Position 0010 00-38
 Spray Does Not Occur On Either Drum When Water Spray Switch is in Intermittent Spray Position 0010 00-40
 Spray Occurs On One Drum Only 0010 00-40
 Water Consumption is Unequal Between Tanks 0010 00-43
 Water Spray Pressure is Low 0010 00-42

END OF WORK PACKAGE

Table 1. Troubleshooting Procedures.

MALFUNCTION	TEST OR INSPECTION	CORRECTIVE ACTION
<p>1. Engine Cranks But Will Not Start or is Hard to Start.</p>	<p>ENGINE</p> <p>1. Check fuel level reading on fuel level gauge.</p>	<p>a. If fuel level gauge reads empty, fill fuel tank with fuel (WP 0015 00).</p> <p>b. If fuel level gauge indicates fuel in tank, go to Step 2.</p>
<div style="display: flex; justify-content: space-around; align-items: center;"> <div data-bbox="337 716 1036 1287"> <p style="text-align: center;">FUEL LEVEL GAUGE</p> </div> <div data-bbox="1052 863 1333 1472"> </div> </div> <p data-bbox="331 1325 488 1358">CB534B SHOWN</p> <p data-bbox="1273 1476 1338 1497">401-030</p>		

Table 1. Troubleshooting Procedures - Continued.

MALFUNCTION	TEST OR INSPECTION	CORRECTIVE ACTION
ENGINE - CONTINUED		
<p>1. Engine Cranks But Will Not Start or is Hard to Start - Continued.</p>	<div style="text-align: center;">  <p>WARNING</p> <ul style="list-style-type: none"> • DO NOT perform fuel system checks, inspections or maintenance while smoking or near fire, flames or sparks. Fuel may ignite, causing injury, death or damage to roller. • Wear fuel-resistant gloves when handling fuels and promptly wash exposed skin and change fuel-soaked clothing. <p>NOTE</p> <p>Use a container to catch any fuel that may drain from system. Dispose of fuel IAW local policy and ordinances. Ensure that all spills are cleaned up.</p> </div> <p>2. Remove padlock, fuel cap assembly and strainer and visually inspect tank for fuel (WP 0015 00).</p>	<p>a. If fuel tank is empty, fuel level gauge does not operate. Install strainer in tank and fill fuel tank with fuel (WP 0015 00). Notify supervisor that fuel gauge does not operate.</p> <p>b. If fuel tank contains fuel, replace strainer, fuel cap assembly and padlock and go to Step 3.</p>
<div style="text-align: center;">  </div>		
<p>401-083</p>		

Table 1. Troubleshooting Procedures - Continued.

MALFUNCTION	TEST OR INSPECTION	CORRECTIVE ACTION
ENGINE - CONTINUED		
<p>1. Engine Cranks But Will Not Start or is Hard to Start - Continued.</p>	<p>3. Open left-side door assembly (WP 0005 00) and open fuel/water separator drain valve to drain water from fuel/water separator (WP 0016 00). Close drain valve. On CB534C only, also drain fuel/water separator on right side of engine compartment.</p> <p>4. Check air filter service indicator for red indication in viewing window. Red indicates a clogged air cleaner primary or secondary element. If filter service indicator shows red in viewing window, unlatch two air cleaner housing latches and remove cover. Remove primary and secondary elements from air cleaner housing.</p>	<p>a. If engine still does not start, go to Step 4.</p> <p>b. If engine starts, close right-and/or left-side door assembly (WP 0005 00).</p> <p>a. If air cleaner primary element is clogged, clean by tapping element with hand to remove dirt. Install secondary and primary filter elements and cover and close two air cleaner housing latches. Reset air filter service indicator. Close left-side door assembly (WP 0005 00).</p>

401-084

Table 1. Troubleshooting Procedures - Continued.

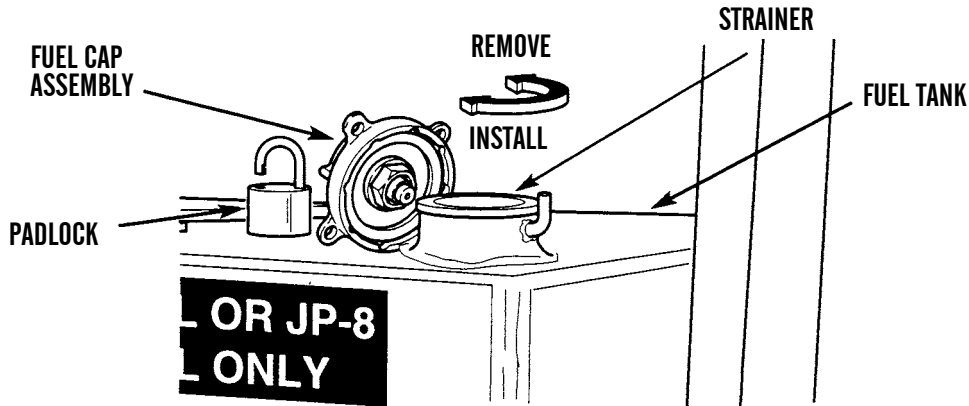
MALFUNCTION	TEST OR INSPECTION	CORRECTIVE ACTION
ENGINE - CONTINUED		
<p>1. Engine Cranks But Will Not Start or is Hard to Start - Continued.</p>	<p>5. Check exhaust system exit (tail pipe) for restrictions such as mud or ice.</p>	<p>b. If air cleaner primary element is torn, or ripped, notify supervisor for replacement. Install secondary and primary filter elements and cover and close two air cleaner housing latches. Reset air filter service indicator. Close left-side door assembly (WP 0005 00).</p> <p>c. If air cleaner secondary element is clogged, notify supervisor for replacement. Install secondary and primary filter elements and cover and close two air cleaner housing latches. Reset air filter indicator. Close left-side door assembly (WP 0005 00).</p> <p>d. If air cleaner elements are not clogged and fault is not corrected, install filter elements and cover and close two air cleaner housing latches. Close left-side door assembly (WP 0005 00) and go to Step 5.</p> <p>a. If restrictions exist, remove restrictions.</p> <p>b. If no restrictions exist and starting aid was used during attempt to start, go to Step 6.</p> <p>c. If no restrictions exist and starting aid was not used during attempt to start, go to Step 6.</p>

Table 1. Troubleshooting Procedures - Continued.

MALFUNCTION	TEST OR INSPECTION	CORRECTIVE ACTION
ENGINE - CONTINUED		
<p>1. Engine Cranks But Will Not Start or is Hard to Start - Continued.</p>	<p>6. On CB534B only, turn fuse holder cap to left and remove cap and fuse from fuse holder labeled START AID. Inspect fuse for broken filament.</p>	<p>a. If fuse filament is broken, notify supervisor for replacement.</p> <p>b. If fuse filament is not broken, fault is not corrected. Install fuse and cap in fuse holder and notify supervisor that engine cranks but will not start or is hard to start.</p>

Table 1. Troubleshooting Procedures - Continued.

MALFUNCTION	TEST OR INSPECTION	CORRECTIVE ACTION
ENGINE - CONTINUED		
<p>2. Engine Starts But Will Not Keep Running.</p>	<p>1. Check fuel level reading on fuel level gauge.</p>	<p>a. If fuel level gauge reads empty, fill fuel tank with fuel (WP 0015 00).</p> <p>b. If fuel level gauge indicates fuel in tank, go to Step 2.</p>
<div style="display: flex; justify-content: space-around; align-items: center;"> <div data-bbox="337 709 1031 1281"> <p style="text-align: center;">FUEL LEVEL GAUGE</p> </div> <div data-bbox="1055 856 1331 1459"> </div> </div> <p data-bbox="332 1318 487 1354">CB534B SHOWN</p> <p data-bbox="1274 1470 1339 1491">401-030</p>		

Table 1. Troubleshooting Procedures - Continued.

MALFUNCTION	TEST OR INSPECTION	CORRECTIVE ACTION
ENGINE - CONTINUED		
<p>2. Engine Starts But Will Not Keep Running - Continued.</p>	<div style="text-align: center;">  <p>WARNING</p> <ul style="list-style-type: none"> • DO NOT perform fuel system checks, inspections or maintenance while smoking or near fire, flames or sparks. Fuel may ignite, causing injury, death or damage to roller. • Wear fuel-resistant gloves when handling fuels and promptly wash exposed skin and change fuel-soaked clothing. <p>NOTE</p> <p>Use a container to catch any fuel that may drain from system. Dispose of fuel IAW local policy and ordinances. Ensure that all spills are cleaned up.</p> <p>2. Remove padlock, fuel cap assembly and strainer and visually inspect vent for damage or restriction.</p> </div>	<ul style="list-style-type: none"> a. If fuel cap assembly vent is restricted, remove restriction. b. If fuel cap assembly or vent is damaged, notify supervisor. c. If fuel cap assembly is not damaged or restricted, go to Step 3.
		
<p>401-083</p>		

Table 1. Troubleshooting Procedures - Continued.

MALFUNCTION	TEST OR INSPECTION	CORRECTIVE ACTION
ENGINE - CONTINUED		
<p>2. Engine Starts But Will Not Keep Running - Continued.</p>	<p>3. Remove strainer and visually inspect fuel in fuel tank.</p> <p>4. Open right- and/or left-side door assembly (WP 0005 00).</p> <p>5. Open left-side door assembly (WP 0005 00). Check air filter service indicator for red indication on viewing window. Red indicates a clogged air cleaner primary or secondary element. If filter service indicator shows red in viewing window, unlatch two air cleaner housing latches and remove cover. Remove primary and secondary elements from air cleaner housing.</p>	<p>a. If fuel tank is empty, fuel level gauge does not operate. Install strainer and fill fuel tank with fuel (WP 0015 00). Notify supervisor that fuel level gauge does not operate.</p> <p>b. If fuel is contaminated, notify supervisor.</p> <p>c. If fuel tank contains clean fuel, install strainer, fuel cap assembly and padlock and go to Step 4.</p> <p>a. Open fuel/water separator(s) drain valve(s) and drain separator(s) (WP 0016 00).</p> <p>b. If engine still does not keep running, go to Step 5.</p> <p>a. If air cleaner primary element is clogged, clean by tapping element with hand to remove dirt. Install secondary and primary filter elements and cover and close two air cleaner housing latches. Reset air filter service indicator. Close left-side door assembly (WP 0005 00).</p>

Table 1. Troubleshooting Procedures - Continued.

MALFUNCTION	TEST OR INSPECTION	CORRECTIVE ACTION
ENGINE - CONTINUED		
<p>2. Engine Starts But Will Not Keep Running - Continued.</p>		<p>b. If air cleaner primary element is torn or ripped, notify supervisor for replacement. Install secondary and primary filter elements and cover and close two air cleaner housing latches. Reset air filter service indicator. Close left-side door assembly (WP 0005 00).</p> <p>c. If air cleaner secondary element is clogged, notify supervisor for replacement. Install secondary and primary filter elements and cover and close two air cleaner housing latches. Reset air filter service indicator. Close left-side door assembly (WP 0005 00).</p> <p>d. If air cleaner elements are not clogged and fault is not corrected, install filter elements and cover and close two air cleaner housing latches. Close left-side door assembly (WP 0005 00). Notify supervisor.</p>

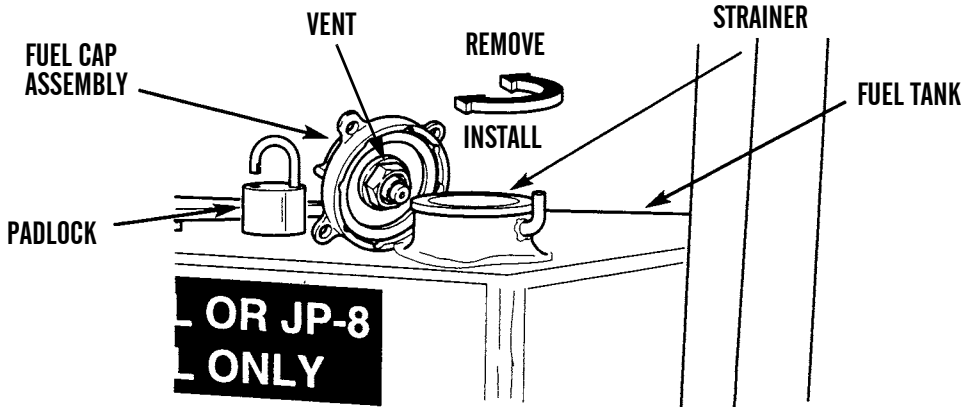
Table 1. Troubleshooting Procedures - Continued.

MALFUNCTION	TEST OR INSPECTION	CORRECTIVE ACTION
ENGINE - CONTINUED		
<p>3. Engine is Sluggish.</p>	<p>1. Check fuel level reading on fuel level gauge.</p>	<p>a. If fuel level gauge reads empty, fill fuel tank with fuel (WP 0015 00).</p> <p>b. If fuel level gauge indicates fuel in tank, go to Step 2.</p>
<div style="display: flex; justify-content: space-around; align-items: center;"> <div data-bbox="337 709 1031 1281"> <p style="text-align: center;">FUEL LEVEL GAUGE</p> </div> <div data-bbox="1055 856 1331 1459"> </div> </div> <p data-bbox="332 1318 487 1354" style="margin-top: 20px;">CB534B SHOWN</p> <p data-bbox="1274 1470 1339 1491" style="text-align: right; margin-top: 20px;">401-030</p>		

Table 1. Troubleshooting Procedures - Continued.

MALFUNCTION	TEST OR INSPECTION	CORRECTIVE ACTION
ENGINE - CONTINUED		
<p>3. Engine is Sluggish - Continued.</p>	<div style="text-align: center;">  <p>WARNING</p> <ul style="list-style-type: none"> • DO NOT perform fuel system checks, inspections or maintenance while smoking or near fire, flames or sparks. Fuel may ignite, causing injury, death or damage to roller. • Wear fuel-resistant gloves when handling fuels and promptly wash exposed skin and change fuel-soaked clothing. <p>NOTE</p> <p>Use a container to catch any fuel that may drain from system. Dispose of fuel IAW local policy and ordinances. Ensure that all spills are cleaned up.</p> </div> <p>2. Remove padlock, fuel cap assembly and strainer and visually inspect vent for damage or restriction.</p>	<p>a. If fuel cap assembly vent is restricted, remove restriction.</p> <p>b. If fuel cap assembly or vent is damaged, notify supervisor to replace fuel cap assembly.</p> <p>c. If fuel cap assembly is not damaged or restricted, go to Step 3.</p>
		
<p>401-083</p>		

Table 1. Troubleshooting Procedures - Continued.

MALFUNCTION	TEST OR INSPECTION	CORRECTIVE ACTION
ENGINE - CONTINUED		
<p>3. Engine is Sluggish - Continued.</p>	<p>3. Remove strainer and visually inspect fuel in fuel tank.</p> <p>4. Open right- and/or left-side door assembly (WP 0005 00).</p>	<p>a. If fuel tank is empty, fuel level gauge does not operate. Install strainer and fill fuel tank with fuel (WP 0015 00). Notify supervisor.</p> <p>b. If fuel is contaminated with dirt, drain fuel tank and fill with clean fuel (WP 0019 00). Notify supervisor.</p> <p>c. If fuel tank contains clean fuel, install strainer, fuel cap assembly and padlock and go to Step 4.</p> <p>a. Open fuel/water separator(s) drain valve(s) and drain separator(s) (WP 0016 00).</p> <p>b. If engine is still sluggish, go to Step 5.</p> <p>c. If engine is no longer sluggish, close left-side door assembly (WP 0005 00).</p>

Table 1. Troubleshooting Procedures - Continued.

MALFUNCTION	TEST OR INSPECTION	CORRECTIVE ACTION
ENGINE - CONTINUED		
<p>3. Engine is Sluggish - Continued.</p>	<p>5. Check air filter service indicator for red indication in viewing window. Red indicates a clogged air cleaner primary or secondary element. If filter service indicator shows red in viewing window, unlatch two air cleaner housing latches and remove cover. Remove primary and secondary elements from air cleaner housing.</p>	<p>a. If air cleaner primary element is clogged, clean by tapping element with hand to remove dirt. Install secondary and primary filter elements and cover and close two air cleaner housing latches. Reset air filter service indicator. Close left-side door assembly (WP 0005 00).</p> <p>b. If air cleaner primary element is torn or ripped, notify supervisor for replacement. Install secondary and primary filter elements and cover and close two air cleaner housing latches. Reset air filter service indicator. Close left-side door assembly (WP 0005 00).</p>

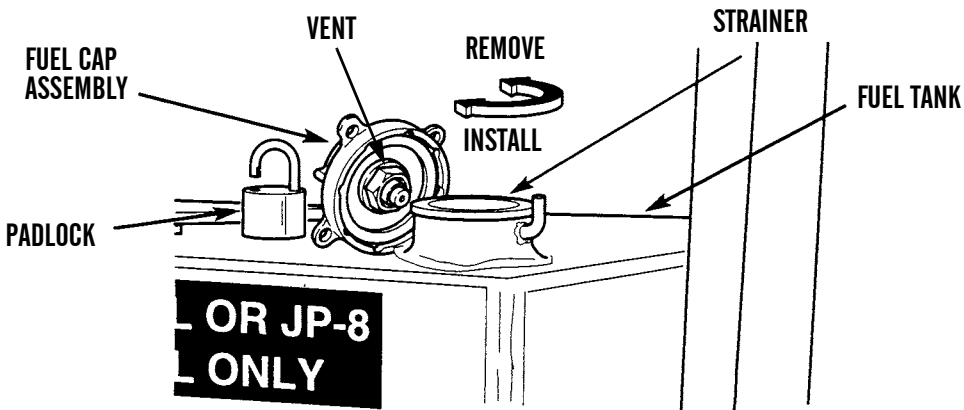
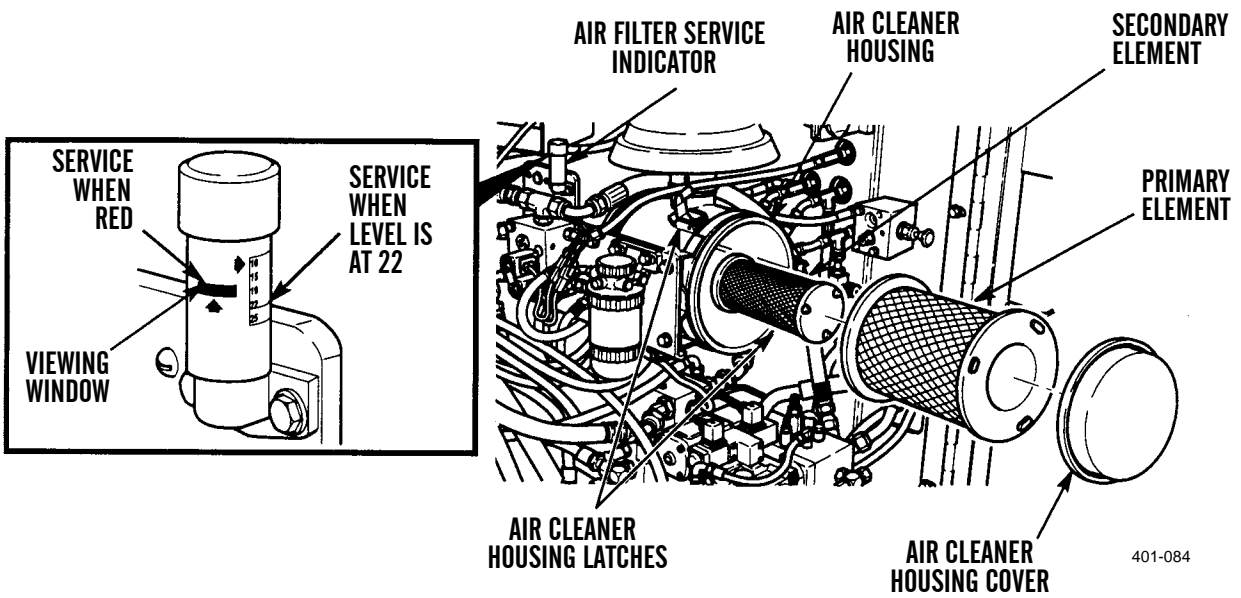

Table 1. Troubleshooting Procedures - Continued.

MALFUNCTION	TEST OR INSPECTION	CORRECTIVE ACTION
<i>ENGINE - CONTINUED</i>		
<p>3. Engine is Sluggish - Continued.</p>		<p>c. If air cleaner secondary element is clogged, notify supervisor for replacement. Install secondary and primary filter elements and cover and close two air cleaner housing latches. Reset air filter service indicator. Close left-side door assembly (WP 0005 00).</p> <p>d. If air cleaner elements are not clogged and fault is not corrected, install filter elements and cover and close two air filter housing latches. Close left-side door assembly (WP 0005 00) and notify supervisor.</p>
<p>4. Engine Exhaust Smokes Excessively (Too Much Black or Gray Smoke).</p>	<p>1. Open left-side door assembly (WP 0005 00) and check air filter service indicator for red indication in viewing window. Red indicates a clogged air cleaner primary or secondary element. If filter service indicator shows red in viewing window, unlatch two air cleaner housing latches and remove cover. Remove primary and secondary elements for air cleaner housing.</p>	<p>a. If air cleaner primary element is clogged, clean by tapping element with hand to remove dirt. Install secondary and primary filter elements and cover and close two air cleaner housing latches. Reset air filter service indicator. Close left-side door assembly (WP 0005 00).</p> <p>b. If air cleaner primary element is torn or ripped, notify supervisor for replacement. Install secondary and primary filter elements and cover and close two air cleaner housing latches. Reset air service indicator. Close left-side door assembly (WP 0005 00).</p>

Table 1. Troubleshooting Procedures - Continued.

MALFUNCTION	TEST OR INSPECTION	CORRECTIVE ACTION
ENGINE - CONTINUED		
<p>4. Engine Exhaust Smokes Excessively (Too Much Black or Gray Smoke) - Continued.</p>		<p>c. If air cleaner secondary element is clogged, notify supervisor for replacement. Install secondary and primary filter elements and cover and close two air cleaner housing latches. Reset air filter service indicator. Close left-side door assembly (WP 0005 00).</p> <p>d. If air cleaner elements are not clogged and starting aid was used during attempt to start, install filter elements and cover and close two air filter housing latches. Close left-side door assembly (WP 0005 00) and go to Step 2.</p>
<p style="text-align: right;">401-084</p>		

Table 1. Troubleshooting Procedures - Continued.

MALFUNCTION	TEST OR INSPECTION	CORRECTIVE ACTION
<i>ENGINE - CONTINUED</i>		
<p>4. Engine Exhaust Smokes Excessively (Too Much Black or Gray Smoke) - Continued.</p>		<p>e. If air cleaner elements are not clogged and starting aid was not used during attempt to start, fault is not corrected. Install filter elements and cover and close two air filter housing latches. Close left-side door assembly (WP 0005 00). Notify supervisor that engine exhaust smokes excessively.</p>
<p>5. Engine Misfires or Idles Rough.</p>	<p>1. Open left-side door assembly (WP 0005 00) and check air filter service indicator for red indication in viewing window. Red indicates a clogged air cleaner primary or secondary element. If filter service indicator shows red in viewing window, unlatch two air cleaner housing latches and remove cover. Remove primary and secondary elements from air cleaner housing.</p>	<p>a. If air cleaner primary element is clogged, clean by tapping element with hand to remove dirt. Install secondary and primary filter elements and cover and close two air cleaner housing latches. Reset air filter service indicator. Close left-side door assembly (WP 0005 00).</p> <p>b. If air cleaner primary element is torn or ripped, notify supervisor for replacement. Install secondary and primary filter elements and cover and close two air cleaner housing latches. Reset air filter service indicator. Close left-side door assembly (WP 0005 00).</p>

Table 1. Troubleshooting Procedures - Continued.

MALFUNCTION	TEST OR INSPECTION	CORRECTIVE ACTION
ENGINE - CONTINUED		
<p>5. Engine Misfires or Idles Rough -Continued.</p>		<p>c. If air cleaner secondary element is clogged, notify supervisor for replacement. Install secondary and primary filter elements and cover and close two air cleaner housing latches. Reset air filter service indicator. Close left-side door assembly (WP 0005 00).</p> <p>d. If air cleaner elements are not clogged and fault is not corrected, install filter elements cover, and close two air filter housing latches. Go to Step 2.</p>

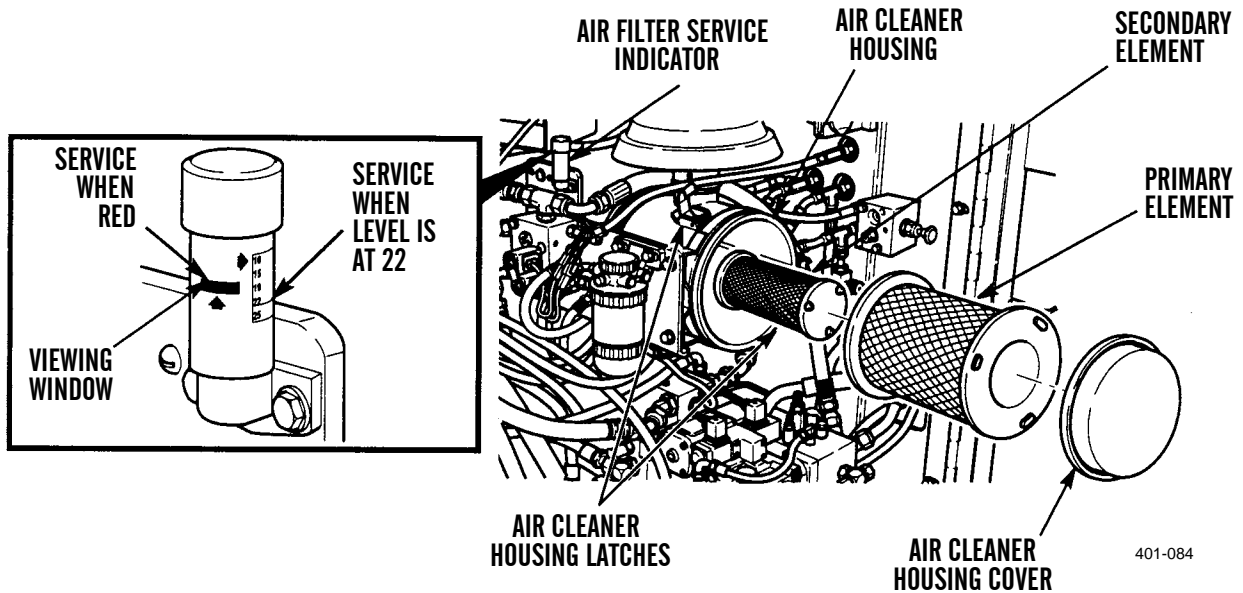

Table 1. Troubleshooting Procedures - Continued.

MALFUNCTION	TEST OR INSPECTION	CORRECTIVE ACTION
ENGINE - CONTINUED		
<p>5. Engine Misfires or Idles Rough -Continued.</p>	<div style="text-align: center;">  <p>WARNING</p> <ul style="list-style-type: none"> • DO NOT perform fuel system checks, inspections or maintenance while smoking or near fire, flames or sparks. Fuel may ignite, causing injury, death or damage to roller. • Wear fuel-resistant gloves when handling fuels and promptly wash exposed skin and change fuel-soaked clothing. <p>NOTE</p> <p>Use a container to catch any fuel that may drain from system. Dispose of fuel IAW local policy and ordinances. Ensure that all spills are cleaned up.</p> </div> <p>2. Open right- and/or left-side door assembly (WP 0005 00).</p>	<p>a. Open fuel/water separator(s) drain valve(s), and drain separator(s) (WP 0016 00).</p> <p>b. If engine still idles rough, fault is not corrected. Notify supervisor.</p>
<div style="display: flex; justify-content: space-around; align-items: flex-start;"> <div style="border: 1px solid black; padding: 5px; width: 25%;">  <p>SERVICE WHEN RED</p> <p>SERVICE WHEN LEVEL IS AT 22</p> <p>VIEWING WINDOW</p> </div> <div style="text-align: center;">  <p>AIR FILTER SERVICE INDICATOR</p> <p>AIR CLEANER HOUSING</p> <p>SECONDARY ELEMENT</p> <p>PRIMARY ELEMENT</p> <p>AIR CLEANER HOUSING LATCHES</p> <p>AIR CLEANER HOUSING COVER</p> </div> </div> <p style="text-align: right; font-size: small;">401-084</p>		

Table 1. Troubleshooting Procedures - Continued.

MALFUNCTION	TEST OR INSPECTION	CORRECTIVE ACTION
ENGINE - CONTINUED		
<p>6. Engine Oil Pressure is Low (Warning Light and Warning Horn On).</p>	<p>Turn engine off immediately. Open right-side door assembly (WP 0005 00). Check oil level (WP 0014 00).</p>	<p>a. If oil is below low mark, oil level is low. Install engine oil gauge rod (dipstick) in tube. Add oil (WP 0014 00) and notify supervisor that engine oil pressure was low (warning light and warning horn on).</p> <p>b. If oil is between marks, oil level is correct. Fault is not corrected. Install engine oil gauge rod (dipstick) in tube, close right-side door assembly (WP 0005 00) and notify supervisor that engine oil pressure is low (warning light and warning horn on).</p>

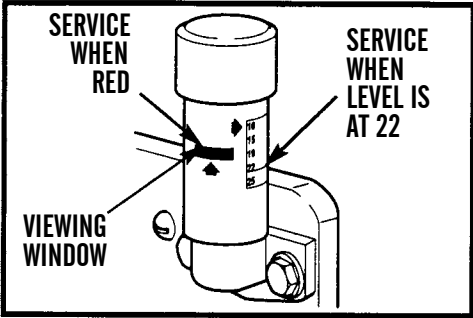
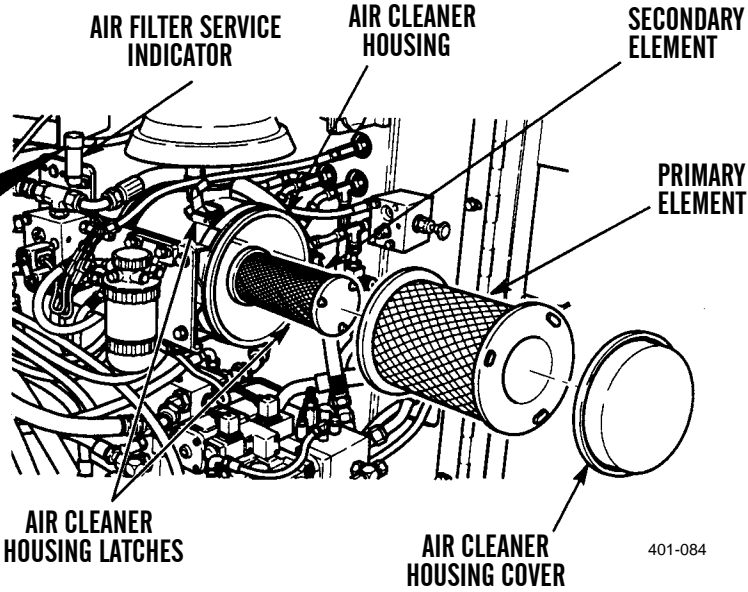
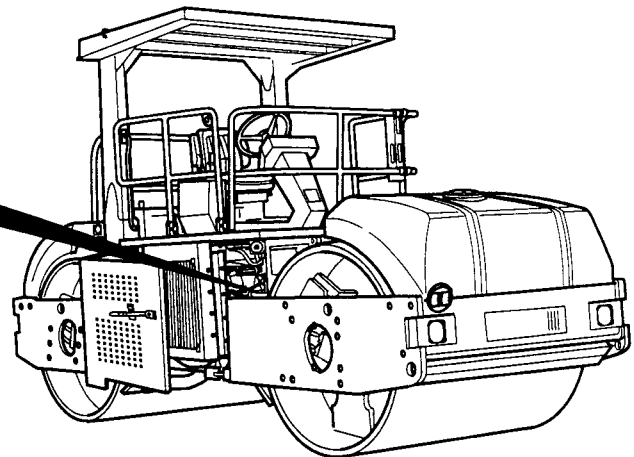
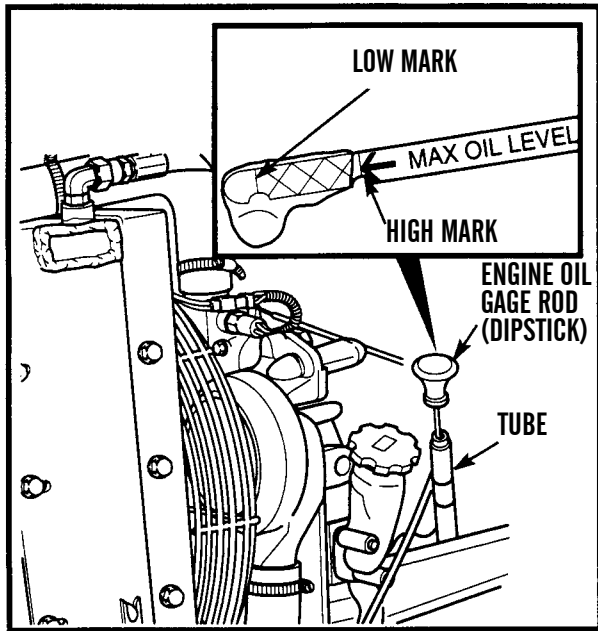

401-086

Table 1. Troubleshooting Procedures - Continued.

MALFUNCTION	TEST OR INSPECTION	CORRECTIVE ACTION
ENGINE - CONTINUED		
<p>7. Engine is Unusually Noisy.</p>	<p>1. Check muffler and exhaust system for loose or damaged components.</p>	<p>a. If muffler or exhaust components are loose or damaged, fault not corrected. Notify supervisor that muffler or exhaust components are loose or damaged.</p> <p>b. If muffler or exhaust components are not loose or damaged, go to Step 2.</p>
<p>8. Engine Surges (Speed Changes).</p>	<div style="text-align: center;">  <p>WARNING</p> <ul style="list-style-type: none"> • DO NOT perform fuel system checks, inspections or maintenance while smoking or near fire, flames or sparks. Fuel may ignite, causing injury, death or damage to roller. • Wear fuel-resistant gloves when handling fuels and promptly wash exposed skin and change fuel-soaked clothing. <p>NOTE</p> <p>Use a container to catch any fuel that may drain from system. Dispose of fuel IAW local policy and ordinances. Ensure that all spills are cleaned up.</p> </div> <p>1. Remove padlock and fuel cap assembly and visually inspect vent for damage or restriction.</p> <p>2. Open right- and/or left-side door assembly (WP 0005 00).</p>	<p>a. If fuel cap assembly vent is restricted, remove restriction.</p> <p>b. If fuel cap assembly or vent is damaged, notify supervisor to replace fuel cap assembly.</p> <p>c. If fuel cap assembly is not damaged or restricted, go to Step 2.</p> <p>a. Open drain valve(s) and drain fuel/water separator(s) (WP 0016 00).</p> <p>b. If engine still surges, fault is not corrected. Notify supervisor that engine surges.</p>

Table 1. Troubleshooting Procedures - Continued.

MALFUNCTION	TEST OR INSPECTION	CORRECTIVE ACTION
ENGINE - CONTINUED		
<p>9. Engine is Using More Fuel Than Usual.</p>	<p>1. Open left-side door assembly (WP 0005 00) and check air filter service indicator for red indication in viewing window. Red indicates a clogged air cleaner primary or secondary element. If filter service indicator shows red in viewing window, unlatch two air cleaner housing latches and remove cover. Remove primary and secondary elements from air cleaner housing.</p>	<p>a. If air cleaner primary element is clogged, clean by tapping element with hand to remove dirt. Install secondary and primary filter elements and cover and close two air cleaner housing latches. Reset air filter service indicator. Close left-side door assembly (WP 0005 00).</p> <p>b. If air cleaner primary element is torn or ripped, notify supervisor for replacement. Install secondary and primary filter elements and cover and close two air cleaner housing latches. Reset air filter service indicator. Close left-side door assembly (WP 0005 00).</p>

401-084

Table 1. Troubleshooting Procedures - Continued.

MALFUNCTION	TEST OR INSPECTION	CORRECTIVE ACTION
ENGINE - CONTINUED		
<p>9. Engine is Using More Fuel Than Usual - Continued.</p>		<p>c. If air cleaner secondary element is clogged, notify supervisor for replacement. Install secondary and primary filter elements and cover and close two air cleaner housing latches. Reset air filter service indicator. Close left-side door assembly (WP 0005 00).</p> <p>d. If air cleaner elements are not clogged and fault is not corrected, install filter elements and cover and close two air cleaner housing latches. Close left-side door assembly (WP 0005 00). Notify supervisor of excessive fuel consumption.</p>

Table 1. Troubleshooting Procedures - Continued.

MALFUNCTION	TEST OR INSPECTION	CORRECTIVE ACTION
ENGINE - CONTINUED		
<p>10. Engine Operating Temperature Is Too High (Warning Light and Warning Horn On).</p>	<p>1. Check operating conditions and ambient temperature. When roller is operated continuously in ambient temperatures above 120°F (50°C) at high amplitude and at high propel speed, engine can easily overheat.</p> <p>2. Open right-side door assembly (WP 0005 00) and check for loose or broken alternator V-belts.</p>	<p>a. If ambient temperature is above 120°F (50°C), allow roller to cool. Operate roller in low amplitude (WP 0005 00) and reduce travel speed.</p> <p>b. If operating conditions and ambient temperature are normal, go to Step 2.</p> <p>a. If alternator V-belt is broken, component is faulty. Close right-side door assembly (WP 0005 00) and notify supervisor.</p> <p>b. If alternator drive V-belts are loose, notify supervisor.</p> <p>c. If alternator V-belts are not loose or broken, go to Step 3.</p>
401-087		

Table 1. Troubleshooting Procedures - Continued.

MALFUNCTION	TEST OR INSPECTION	CORRECTIVE ACTION
ENGINE - CONTINUED		
<p>10. Engine Operating Temperature is Too High (Warning Light and Warning Horn On) - Continued.</p>	<p>3. Check for air flow restriction in radiator.</p>	<p>a. If air flow through radiator is restricted, remove restriction. If unable to remove restrictions, notify supervisor.</p> <p>b. If air flow through radiator is not restricted, go to Step 4.</p>
		
WARNING		
<ul style="list-style-type: none"> • DO NOT service cooling system unless engine has cooled. This is a pressurized cooling system and escaping steam or hot coolant may cause burns. • DO NOT remove cooling system radiator cap when engine is hot. Allow engine to cool down. Loosen cap to first stop and let any pressure out of cooling system, then remove cap. Failure to follow this warning may cause burns. 		
	<p>4. Pull lever and open access door. Release lever. Remove radiator cap and check for proper coolant level in radiator (WP 0017 00).</p>	<p>a. If radiator coolant level is low, add coolant (WP 0017 00).</p> <p>b. If radiator coolant level is correct, fault is not corrected. Install radiator cap on radiator, pull lever back and close access door. Release lever. Close right-side door assembly (WP 0005 00) and go to Step 5.</p>
		
401-088		

Table 1. Troubleshooting Procedures - Continued.

MALFUNCTION	TEST OR INSPECTION	CORRECTIVE ACTION
ENGINE - CONTINUED		
<p>10. Engine Operating Temperature is Too High (Warning Light and Warning Horn On) - Continued.</p>	<p>5. Open left-side door assembly (WP 0005 00) and check air filter service indicator for red indication in viewing window. Red indicates a clogged air cleaner primary or secondary element. If filter service indicator shows red in viewing window, unlatch two air cleaner housing latches and remove cover. Remove primary and secondary elements from air cleaner housing.</p>	<p>a. If air cleaner primary element is clogged, clean by tapping element with hand to remove dirt. Install secondary and primary filter elements and cover and close two air cleaner housing latches. Reset air filter service indicator. Close left-side door assembly (WP 0005 00).</p> <p>b. If air cleaner primary element is torn or ripped, notify supervisor for replacement. Install secondary and primary filter elements and cover and close two air cleaner housing latches. Reset air filter service indicator. Close left-side door assembly (WP 0005 00).</p>

Table 1. Troubleshooting Procedures - Continued.

MALFUNCTION	TEST OR INSPECTION	CORRECTIVE ACTION
ENGINE - CONTINUED		
<p>10. Engine Operating Temperature is Too High (Warning Light and Warning Horn On) - Continued.</p>		<p>c. If air cleaner secondary element is clogged, notify supervisor for replacement. Install secondary and primary filter elements and cover and close two air cleaner housing latches. Reset air filter service indicator. Close left-side door assembly (WP 0005 00).</p> <p>d. If air cleaner elements are not clogged or damaged, fault is not corrected. Install filter elements and cover and close two air filter housing latches. Close left-side door assembly (WP 0005 00). Notify supervisor that engine temperature is too high (warning light and warning horn on).</p>
<p>The diagram illustrates the air cleaner assembly. It includes a service indicator with a viewing window and a scale. The main assembly consists of the air cleaner housing, which contains a primary element and a secondary element. The housing is secured by two latches and a cover. The service indicator is used to monitor the condition of the filter elements.</p>		

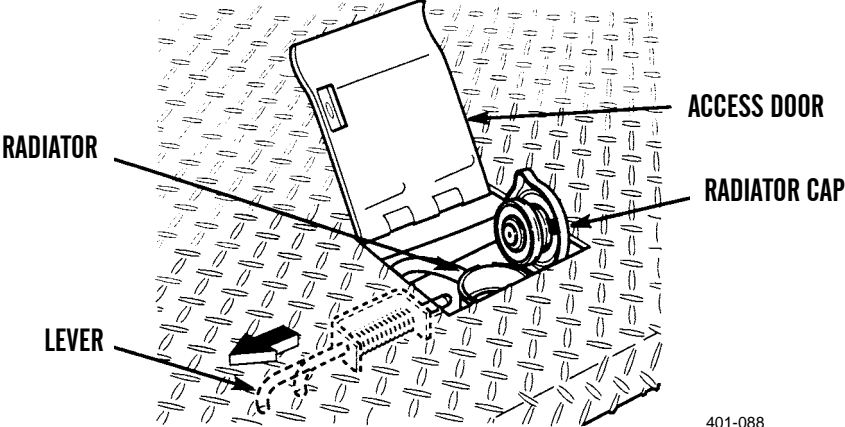
Table 1. Troubleshooting Procedures - Continued.

MALFUNCTION	TEST OR INSPECTION	CORRECTIVE ACTION
ENGINE - CONTINUED		
<p>11. Engine Will Not Stop Running.</p> 		<p>Place battery disconnect switch in OFF position (WP 0005 00). If engine will not stop running notify supervisor.</p>
ELECTRICAL SYSTEM		
<p>12. Roller Has No Electrical Power.</p>	<ol style="list-style-type: none"> 1. Open right-side door assembly (WP 0005 00) and check that battery disconnect switch is in ON position. 2. Open left-side door assembly (WP 0005 00) and press alternator circuit breaker button. 	<ol style="list-style-type: none"> a. If disconnect switch is not in ON position, turn switch to ON position. Close right-side door assembly (WP 0005 00). b. If disconnect switch is in ON position, close right-side door assembly (WP 0005 00) and go to Step 2. <p>If roller still has no electrical power, close left-side door assembly (WP 0005 00) and go to Step 3.</p>

Table 1. Troubleshooting Procedures - Continued.

MALFUNCTION	TEST OR INSPECTION	CORRECTIVE ACTION	
ELECTRICAL SYSTEM - CONTINUED			
<p>12. Roller Has No Electrical Power - Continued.</p>	<div data-bbox="553 506 1127 999" data-label="Image"> </div> <div data-bbox="581 999 1086 1241" data-label="Image"> </div> <p data-bbox="1073 1251 1138 1272" style="text-align: right;">401-090</p> <p data-bbox="721 1289 1078 1444">3. Turn fuse holder cap to left and remove cap and fuse from fuse holder labeled KEY START. Inspect fuse for broken filament.</p>	<p data-bbox="1105 1289 1463 1415">a. If fuse filament is broken, notify supervisor for replacement. Install fuse and cap in fuse holder.</p> <p data-bbox="1105 1461 1463 1587">b. If fuse filament is not broken, fault is not corrected. Install fuse and cap in fuse holder and notify supervisor.</p>	
<div data-bbox="506 1654 1016 1829" data-label="Image"> </div> <p data-bbox="954 1833 1016 1854" style="text-align: right;">401-085</p>			<p>BROKEN FUSE FILAMENT</p>

Table 1. Troubleshooting Procedures - Continued.

MALFUNCTION	TEST OR INSPECTION	CORRECTIVE ACTION
ELECTRICAL SYSTEM - CONTINUED		
<p>13. Starter Does Not Turn or Turns Slowly.</p>	<ol style="list-style-type: none"> 1. Open left-side door assembly (WP 0005 00) and press alternator circuit breaker button. 2. Turn fuse holder caps counterclockwise and remove caps and fuses from fuse holders labeled KEY START and BRAKE. Inspect fuses for broken filament. 	<p>If roller still has no electrical power, close left-side door assembly (WP 0005 00) and go to Step 2.</p> <ol style="list-style-type: none"> a. If either fuse filament is broken, notify supervisor for replacement. Install fuses and caps in fuse holders. b. If fuse filaments are not broken, fault is not corrected. Install fuses and caps in fuse holders and notify supervisor.
<p>The diagram shows the engine compartment with a callout to the 'ALTERNATOR CIRCUIT BREAKER BUTTON'. Below it is a fuse panel with seven fuses labeled: KEY START (10A), BACKUP ALARM (10A), WATER SPRAY (15A), GAUGES (10A), STARTAID (10A), BRAKE (10A), and VIBE (10A). A broken fuse filament is shown with a callout 'BROKEN FUSE FILAMENT'. Reference numbers 401-091 and 401-085 are present.</p>		
<p>14. Starter Turns But Does Not Crank Engine.</p>	<ol style="list-style-type: none"> 1. Open left-side door assembly (WP 0005 00) and press alternator circuit breaker button. 	<p>If roller still has no electrical power, fault is not corrected. Close left-side door assembly (WP 0005 00) and go to Step 2.</p>

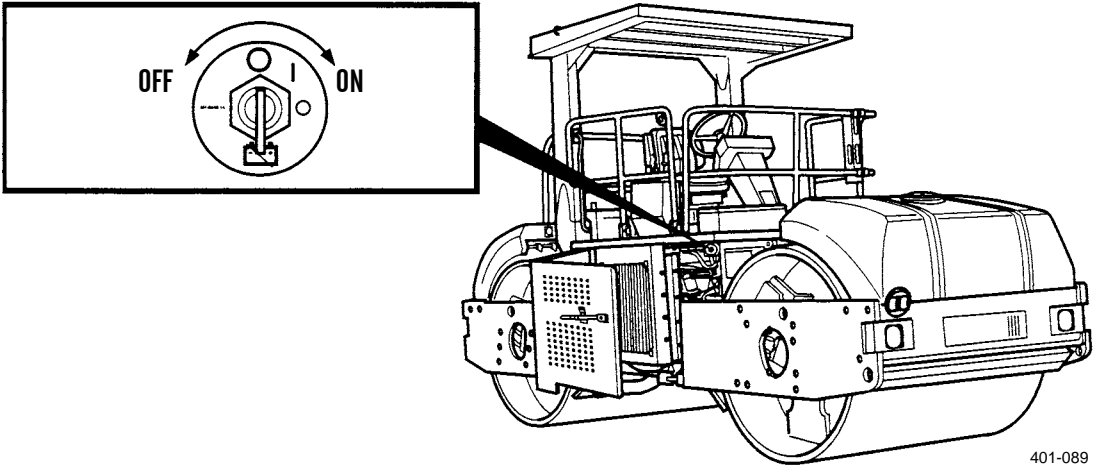
Table 1. Troubleshooting Procedures - Continued.

MALFUNCTION	TEST OR INSPECTION	CORRECTIVE ACTION
<i>ELECTRICAL SYSTEM - CONTINUED</i>		
<p>14. Starter Turns But Does Not Crank Engine - Continued.</p>	<p>2. Turn fuse holder cap counterclockwise and remove cap and fuse from fuse holder labeled KEY START. Inspect fuse for broken filament.</p>	<p>a. If fuse filament is broken, notify supervisor for replacement. Install fuse and cap in fuse holder.</p> <p>b. Fault is not corrected. Notify supervisor.</p>
<p>15. Warning and Indicator Lights Do Not Operate.</p>	<p>Turn fuse holder cap counterclockwise and remove cap and fuse from fuse holder labeled GAUGES. Inspect fuse for broken filament.</p>	<p>a. If fuse filament is broken, notify supervisor for replacement. Install fuse and cap in fuse holder.</p> <p>b. If fuse filament is not broken, fault is not corrected. Install fuse and cap in fuse holder and notify supervisor.</p>
<p>16. Starting Aid Switch Does Not Work (CB534B Roller Only).</p>	<p>For CB534B Roller only, turn fuse holder cap counterclockwise and remove cap and fuse from fuse holder labeled START AID. Inspect fuse for broken filament.</p>	<p>a. If fuse filament is broken, notify supervisor for replacement. Install fuse and cap in fuse holder.</p> <p>b. If fuse filament is not broken, fault is not corrected. Install fuse and cap in fuse holder and notify supervisor.</p>
<p>17. Backup Alarm Does Not Work.</p>	<p>Turn fuse holder cap counterclockwise and remove cap and fuse from fuse holder labeled BACKUP ALARM. Inspect fuse for broken filament.</p>	<p>a. If fuse filament is broken, notify supervisor for replacement. Install fuse and cap in fuse holder.</p> <p>b. If fuse filament is not broken, fault is not corrected. Install fuse and cap in fuse holder and notify supervisor.</p>
<p>18. Alternator Indicator Is On.</p>	<p>Open left-side door assembly (WP 0005 00) and press alternator circuit breaker button.</p>	<p>If alternator indicator is still on, fault is not corrected. Close left-side door assembly (WP 0005 00). Notify supervisor.</p>

Table 1. Troubleshooting Procedures - Continued.

MALFUNCTION	TEST OR INSPECTION	CORRECTIVE ACTION
ELECTRICAL SYSTEM - CONTINUED		
<p>19. Work Lights and Gauge Lights Do Not Operate.</p>	<p>Press lights circuit breaker button.</p>	<p>If work lights and gauge lights still do not operate, fault is not corrected. Notify supervisor.</p>
<p>20. Horn Does Not Operate.</p>	<p>Turn fuse holder cap counterclockwise and remove cap and fuse from fuse holder labeled BACKUP ALARM. Inspect fuse for broken filament.</p>	<p>a. If fuse filament is broken, notify supervisor for replacement. Install fuse and cap in fuse holder.</p> <p>b. If fuse filament is not broken, fault is not corrected. Install fuse and cap in fuse holder and notify supervisor.</p>

Table 1. Troubleshooting Procedures - Continued.

MALFUNCTION	TEST OR INSPECTION	CORRECTIVE ACTION
<i>ELECTRICAL SYSTEM - CONTINUED</i>		
<p>21. Fuel Gauge Does Not Operate.</p>	<p>Turn fuse holder cap counterclockwise and remove cap and fuse from fuse holder labeled GAUGES. Inspect fuse for broken filament.</p>	<p>a. If fuse filament is broken, notify supervisor for replacement. Install fuse and cap in fuse holder.</p> <p>b. If fuse filament is not broken, fault is not corrected. Install fuse and cap in fuse holder and notify supervisor.</p>
<p>22. Vibrations Per Minute (VPM) Gauge Does Not Operate.</p>	<p>Turn fuse holder cap counterclockwise and remove cap and fuse from fuse holder labeled GAUGES. Inspect fuse for broken filament.</p>	<p>a. If fuse filament is broken, notify supervisor for replacement. Install fuse and cap in fuse holder.</p> <p>b. If fuse filament is not broken, fault is not corrected. Install fuse and cap in fuse holder and notify supervisor.</p>
<p>23. No Power to Accessories With Engine Running.</p>	<p>1. Open left-side door assembly (WP 0005 00) and press alternator circuit breaker button.</p>	<p>If roller still has no electrical power, fault is not corrected. Close left-side door assembly (WP 0005 00). Go to Step 2.</p>
<p>401-093</p>		

Table 1. Troubleshooting Procedures - Continued.

MALFUNCTION	TEST OR INSPECTION	CORRECTIVE ACTION
ELECTRICAL SYSTEM - CONTINUED		
<p>23. No Power to Accessories With Engine Running - Continued.</p>	<p>2. Turn fuse holder cap counterclockwise and remove cap and fuse from fuse holder labeled KEY START. Inspect fuse for broken filament.</p>	<p>a. If fuse filament is broken, notify supervisor for replacement. Install fuse and cap in fuse holder.</p> <p>b. If fuse filament is not broken, fault is not corrected. Install fuse and cap in fuse holder and notify supervisor.</p>
<p style="text-align: right; margin-right: 50px;">BROKEN FUSE FILAMENT</p> <p style="text-align: right; margin-right: 50px;">401-085</p>		
HYDRAULIC SYSTEM		
<p>24. Hydraulic Oil Temperature is High (Warning Light and Warning Horn On).</p>	<p>1. Check hydraulic oil level (WP 0018 00).</p>	<p>a. If hydraulic oil level is low, fill hydraulic oil tank (WP 0018 00).</p> <p>b. If hydraulic oil level is not low, fault is not corrected. Notify supervisor.</p>
<p style="text-align: right; margin-right: 50px;">401-087</p>		

Table 1. Troubleshooting Procedures - Continued.

MALFUNCTION	TEST OR INSPECTION	CORRECTIVE ACTION
HYDRAULIC SYSTEM - CONTINUED		
<p>24. Hydraulic Oil Temperature is High (Warning Light and Warning Horn On) - Continued.</p>	<p>2. Open right-side door assembly (WP 0005 00) and check for loose or broken alternator V-belts.</p> <p>3. Check for air flow restriction in radiator and hydraulic oil cooler.</p>	<p>a. If alternator V-belt is broken, component is faulty. Close right-side door assembly (WP 0005 00) and notify supervisor.</p> <p>b. If alternator V-belts are loose, close right-side door assembly (WP 0005 00). Notify supervisor.</p> <p>c. If alternator V-belts are not loose or broken, go to Step 3.</p> <p>a. If air flow through radiator is restricted, remove restrictions. If unable to remove restrictions, close right-side door assembly (WP 0005 00) and notify supervisor.</p> <p>b. If air flow through radiator is not restricted and material being compacted is not too hard, close right-side door assembly (WP 0005 00). Fault is not corrected. Notify supervisor.</p>
<p>25. Hydraulic Oil Pressure is Low (Warning Light and Warning Horn On).</p>	<p>Check hydraulic oil level (WP 0018 00).</p>	<p>a. If hydraulic oil level is low, fill hydraulic oil tank (WP 0018 00).</p> <p>b. If hydraulic oil level is not low, fault is not corrected. Notify supervisor.</p>
STEERING		
<p>26. Power Steering Pump Makes Noise and Steering Cylinder Rods Do Not Move Smoothly.</p>	<p>Check hydraulic oil level (WP 0018 00).</p>	<p>a. If hydraulic oil level is low, fill hydraulic oil tank (WP 0018 00).</p> <p>b. If hydraulic oil is not low, fault is not corrected. Notify supervisor.</p>

Table 1. Troubleshooting Procedures - Continued.

MALFUNCTION	TEST OR INSPECTION	CORRECTIVE ACTION
STEERING - CONTINUED		
<p>27. Too Much Force Is Needed to Turn Steering Wheel.</p>	<p>Check hydraulic oil level (WP 0018 00).</p>	<p>a. If hydraulic oil is low, fill hydraulic oil tank (WP 0018 00). b. If hydraulic oil level is not low, fault is not corrected. Notify supervisor.</p>
<p>28. Roller Does Not Turn When Steering Wheel is Turned.</p>	<p>Check hydraulic oil level (WP 0018 00).</p>	<p>a. If hydraulic oil level is low, fill hydraulic oil tank (WP 0018 00). b. If hydraulic oil level is not low, fault is not corrected. Notify supervisor.</p>
<p>29. Roller Turns Slowly in Both Directions.</p>	<p>Check hydraulic oil level (WP 0018 00).</p>	<p>a. If hydraulic oil level is low, fill hydraulic oil tank (WP 0018 00). b. If hydraulic oil level is not low, fault is not corrected. Notify supervisor.</p>
PROPEL SYSTEM		
<p>30. Roller Will Not Move When Propel Control Lever Is Operated.</p>	<p>1. Check that parking brake is not engaged (parking brake switch is illuminated while parking brake is engaged). 2. Check that parking brake switch was not released with propel control lever out of neutral.</p>	<p>a. If parking brake is engaged, pull parking brake switch up to release parking brake. b. If parking brake is not engaged, go to Step 2. Move propel control lever to neutral. Press down, then pull up parking brake switch. If symptom persists, go to Step 3.</p>

Table 1. Troubleshooting Procedures - Continued.

MALFUNCTION	TEST OR INSPECTION	CORRECTIVE ACTION
PROPEL SYSTEM - CONTINUED		
<p>30. Roller Will Not Move When Propel Control Lever is Operated - Continued.</p>	<p>3. Check hydraulic oil level (WP 0018 00).</p> <p>4. Turn fuse holder cap counterclockwise and remove cap and fuse from fuse holder labeled BRAKE. Inspect fuse for broken filament.</p>	<p>a. If hydraulic oil level is low, fill hydraulic oil tank (WP 0018 00).</p> <p>b. If hydraulic oil level is not low, go to Step 4.</p> <p>a. If fuse filament is broken, notify supervisor for replacement. Install fuse and cap in fuse holder.</p> <p>b. If fuse filament is not broken, fault not corrected. Install fuse and cap in fuse holder and notify supervisor.</p>
		
<p>31. Propel System Engages Very Slowly When Making a Shift.</p>	<p>Check hydraulic oil level (WP 0018 00).</p>	<p>a. If hydraulic oil level is low, fill hydraulic oil tank (WP 0018 00).</p> <p>b. If hydraulic oil level is not low, fault not corrected. Notify supervisor.</p>
<p>32. Propel System Does Not Change Speeds When Propel Speed Switch Is Moved.</p>	<p>Turn fuse holder cap counterclockwise and remove cap and fuse from fuse holder labeled BRAKE. Inspect fuse for broken filament.</p>	<p>a. If fuse filament is broken, notify supervisor for replacement. Install fuse and cap in fuse holder.</p> <p>b. If fuse filament is not broken, fault not corrected. Install fuse and cap in fuse holder and notify supervisor.</p>

Table 1. Troubleshooting Procedures - Continued.

MALFUNCTION	TEST OR INSPECTION	CORRECTIVE ACTION
VIBRATORY SYSTEM		
<p>33. Vibration Frequency Start-up is Slow, Time Lag After Travel Starts is Excessive.</p>	<p style="text-align: center;">NOTE</p> <p>When systems are cold, cold bearing friction can cause slow vibration frequency start-up and excessive lag time after travel starts.</p> <ol style="list-style-type: none"> 1. Ensure that systems are warm. 2. Check vibratory bearing reservoir for correct level of oil (WP 0020 00). 	<ol style="list-style-type: none"> Stop roller, and allow systems to warm up before attempting mission. If symptom persists, go to Step 2. a. If vibratory bearing reservoir is low of oil, fill vibratory bearing reservoir (WP 0020 00). b. If vibratory bearing reservoir oil is at correct level and soil condition and base are correct, fault is not corrected. Notify supervisor.
<p>34. Vibration Mechanism is Noisy.</p>	<p>Check vibratory bearing reservoir for correct level of oil (WP 0020 00).</p>	<ol style="list-style-type: none"> a. If vibratory bearing reservoir oil is low, fill vibratory bearing reservoir (WP 0020 00). b. If vibratory bearing reservoir oil is at correct level, fault is not corrected. Notify supervisor.
<p>35. Vibratory System Will Not Work Forward and Reverse Travel.</p>	<ol style="list-style-type: none"> 1. Check hydraulic oil level (WP 0018 00). 2. Turn fuse holder cap counterclockwise and remove cap and fuse from fuse holder labeled VIBE. Inspect fuse for broken filament. 	<ol style="list-style-type: none"> a. If hydraulic oil level is low, fill hydraulic oil tank (WP 0018 00). b. If hydraulic oil level is not low, fault is not corrected. Notify supervisor. a. If fuse filament is broken, notify supervisor for replacement. Install fuse and cap in fuse holder.

Table 1. Troubleshooting Procedures - Continued.

MALFUNCTION	TEST OR INSPECTION	CORRECTIVE ACTION
VIBRATORY SYSTEM - CONTINUED		
<p>35. Vibratory System Will Not Forward and Reverse Travel - Continued.</p> 		<p>b. If fuse filament is not broken, fault is not corrected. Install fuse and cap in fuse holder and notify supervisor.</p>
<p>36. Vibration Occurs in Only One Drum.</p>	<p>Place drum select switch in center (both drums) position.</p>	<p>If fault is not corrected, notify supervisor.</p>
WATER SPRAY SYSTEM		
<p>37. Spray Does Not Occur On Either Drum When Water Spray Switch is in Continuous Spray Position.</p>	<ol style="list-style-type: none"> 1. Check water level gauges for water in water tanks. Indicator needle pointing full left indicates tank is empty. 2. On CB534B, check that the water tank shutoff valve at each tank is open. Valve handle will be in line with valve when valve is open. 	<ol style="list-style-type: none"> a. If water level is low, add water (WP 0024 00). b. If water level is not low, go to Step 2. <ol style="list-style-type: none"> a. If water tank shutoff valves are not open, open valves. b. If water tank shutoff valves are open, go to Step 3.

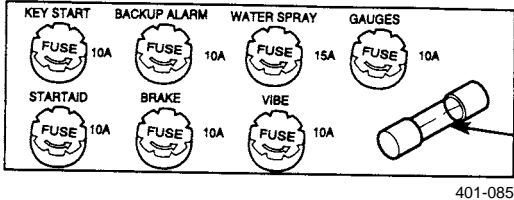
Table 1. Troubleshooting Procedures - Continued.

MALFUNCTION	TEST OR INSPECTION	CORRECTIVE ACTION
WATER SPRAY SYSTEM - CONTINUED		
<p>37. Spray Does Not Occur On Either Drum When Water Spray Switch is in Continuous Spray Position - Continued.</p>		<p style="text-align: right;">401-094</p>
	<p>3. Check water system for frozen water.</p> <p>4. Turn fuse holder cap counterclockwise and remove cap and fuse from fuse holder labeled WATER SPRAY. Inspect fuse for broken filament.</p>	<p>a. If water system is frozen, notify supervisor.</p> <p>b. If water system is not frozen, go to Step 4.</p> <p>a. If fuse filament is broken, notify supervisor for replacement. Install fuse and cap in fuse holder.</p> <p>b. If fuse filament is not broken, component is faulty. Install fuse and cap in fuse holder and notify supervisor.</p>
<p>CB534B ONLY</p>	 <p style="text-align: right;">401-085</p>	<p>BROKEN FUSE FILAMENT</p>

Table 1. Troubleshooting Procedures - Continued.

MALFUNCTION	TEST OR INSPECTION	CORRECTIVE ACTION
WATER SPRAY SYSTEM - CONTINUED		
<p>38. Spray Does Not Occur On Either Drum When Water Spray Switch is in Intermittent Spray Position.</p>	<ol style="list-style-type: none"> 1. Check water level gauges for water in water tanks. Indicator needle pointing full left indicates tank is empty. 2. On CB534B, check that the water tank shutoff valve at each water tank is open. Valve handle will be in line with valve when valve is open. 3. Check water system for frozen water. 4. Turn fuse holder cap counterclockwise and remove cap and fuse from fuse holder labeled WATER SPRAY. Inspect fuse for broken filament. 	<ol style="list-style-type: none"> a. If water level is low, add water (WP 0024 00). b. If water level is not low, go to Step 2. a. If water tank shutoff valves are not open, open valves. b. If water tank shutoff valves are open, go to Step 3. a. If water is frozen, notify supervisor. b. If water in system is not frozen, go to Step 4. a. If fuse filament is broken, notify supervisor for replacement. Install fuse and cap in fuse holder. b. If fuse filament is not broken, component is faulty. Install fuse and cap in fuse holder and notify supervisor.
		
<p>39. Spray Occurs On One Drum Only.</p>	<ol style="list-style-type: none"> 1. Check water level gauges for water in tanks. Indicator needle pointing full left indicates tank is empty. 	<ol style="list-style-type: none"> a. If water level is low, add water (WP 0024 00). b. If water level is not low, go to Step 2.

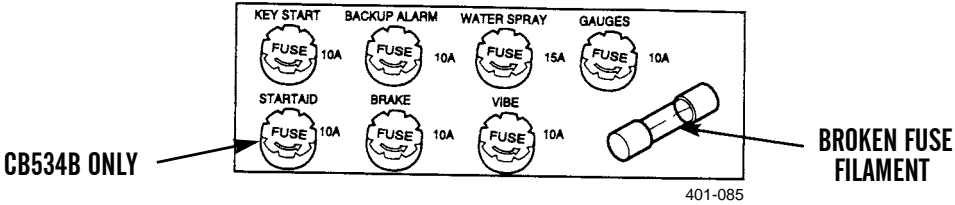
Table 1. Troubleshooting Procedures - Continued.

MALFUNCTION	TEST OR INSPECTION	CORRECTIVE ACTION
WATER SPRAY SYSTEM - CONTINUED		
<p>39. Spray Occurs On One Drum Only - Continued.</p>	<p>2. On CB534B, check that the water tank shutoff valve at the non-operating tank is open. Valve handle will be in-line with the valve when the valve is open.</p>	<p>a. If water tank shutoff valve is not open, open valve.</p> <p>b. If water tank shutoff valve is open, go to Step 3.</p>
<div style="display: flex; justify-content: space-around; align-items: center;">  </div> <p>The diagram shows a close-up of a water tank shutoff valve with a handle. An arrow indicates the handle moving from a 'CLOSED' position to an 'OPEN' position. Below this is a side view of a machine with a 'WATER LEVEL GAUGE' on top and a 'PLATE SHOWN REMOVED FOR CLARITY' on the side. The text 'FRONT SIDE SHOWN REAR SIDE SIMILAR' is also present.</p>		
	<p>3. Check for pinched or damaged water lines.</p>	<p>a. If water line(s) is pinched or damaged, component is faulty. Notify supervisor.</p> <p>b. If water lines are not pinched or damaged, fault is not corrected. Notify supervisor.</p>

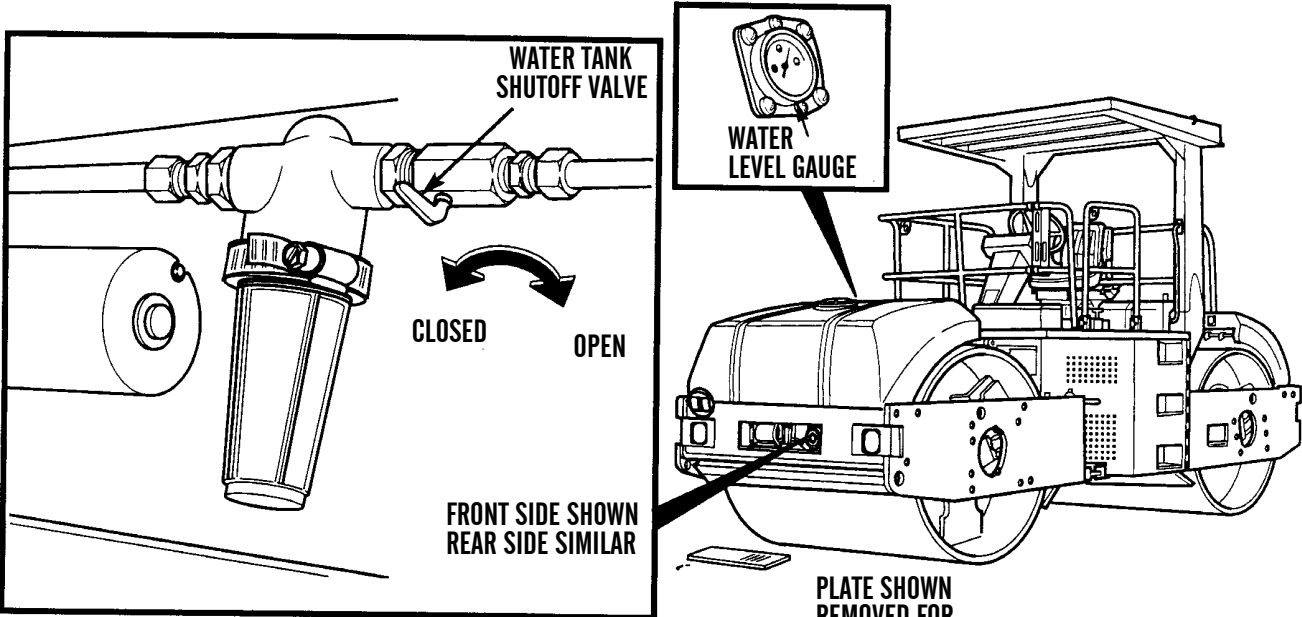
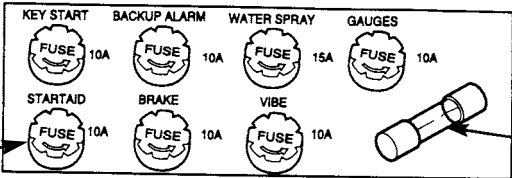
401-094

Table 1. Troubleshooting Procedures - Continued.

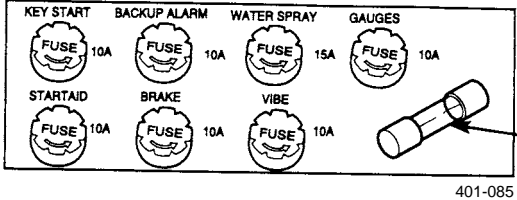
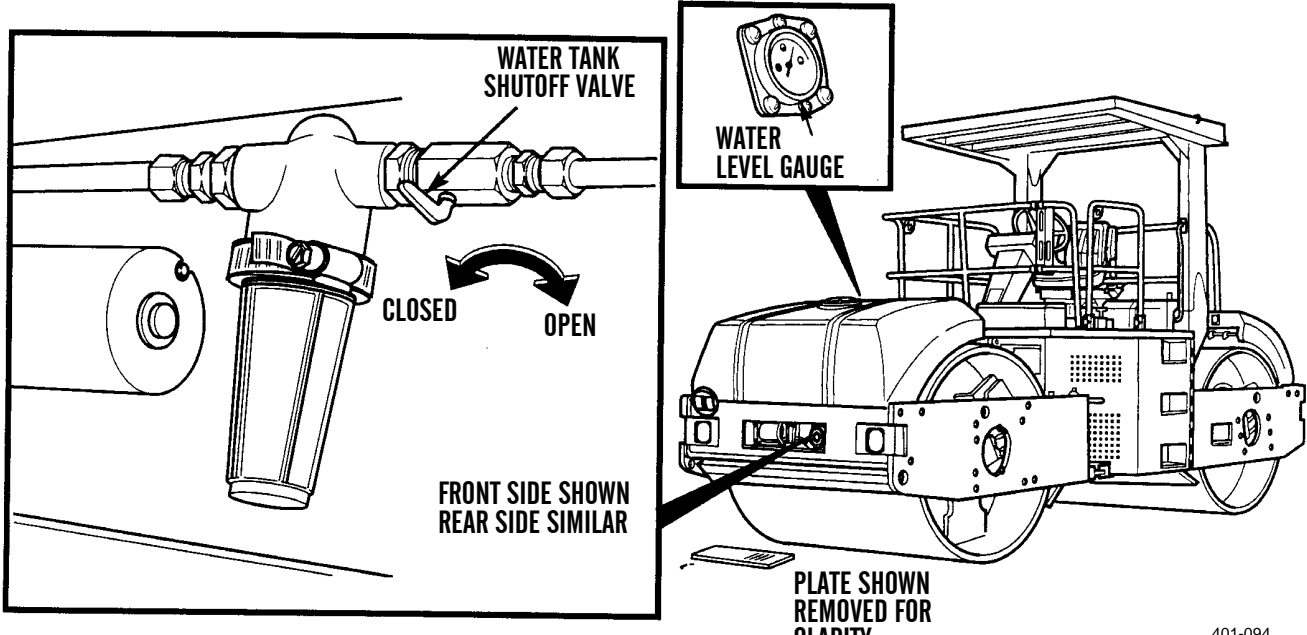
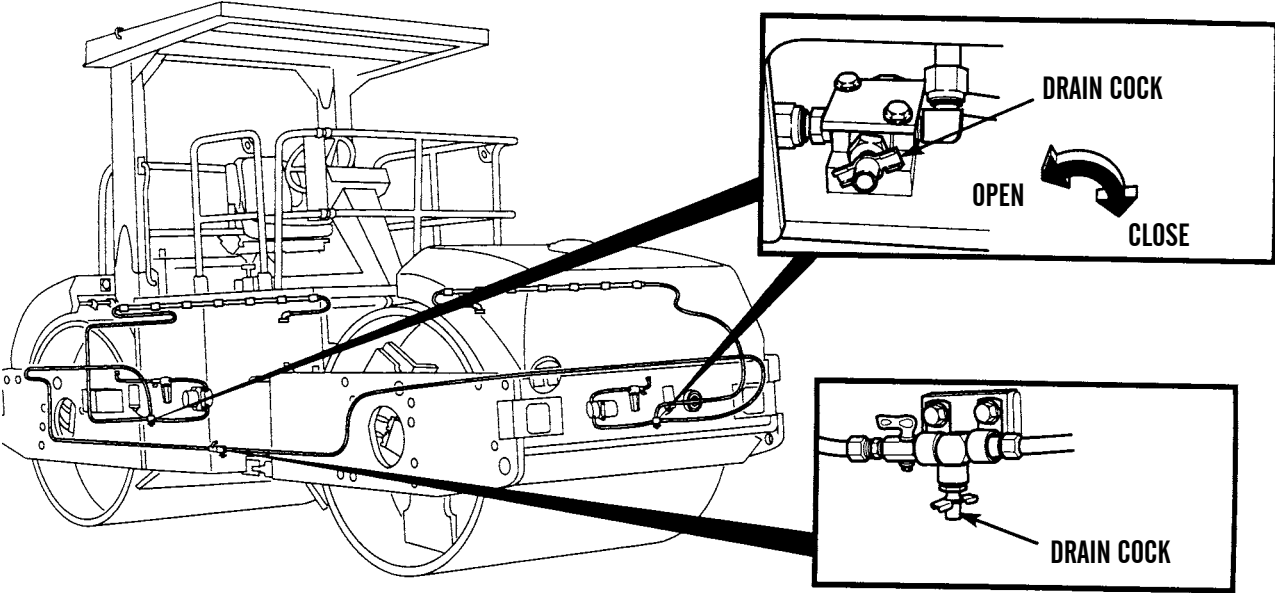
MALFUNCTION	TEST OR INSPECTION	CORRECTIVE ACTION
WATER SPRAY SYSTEM - CONTINUED		
<p>40. Water Spray Pressure is Low.</p> 	<p>1. Check for open drain cocks.</p>	<p>a. If drain cock(s) is open, close drain cock(s).</p> <p>b. If drain cock(s) is closed, go to Step 2.</p>
	<p>2. Check for clogged, corroded, or damaged water spray nozzles (WP 0025 00).</p>	<p>a. If water spray nozzle(s) is dirty, clean and install nozzle(s). Notify supervisor for replacement of components.</p> <p>b. If water spray nozzles are not clogged, corroded, or damaged, fault is not corrected. Notify supervisor.</p>

401-095

Table 1. Troubleshooting Procedures - Continued.

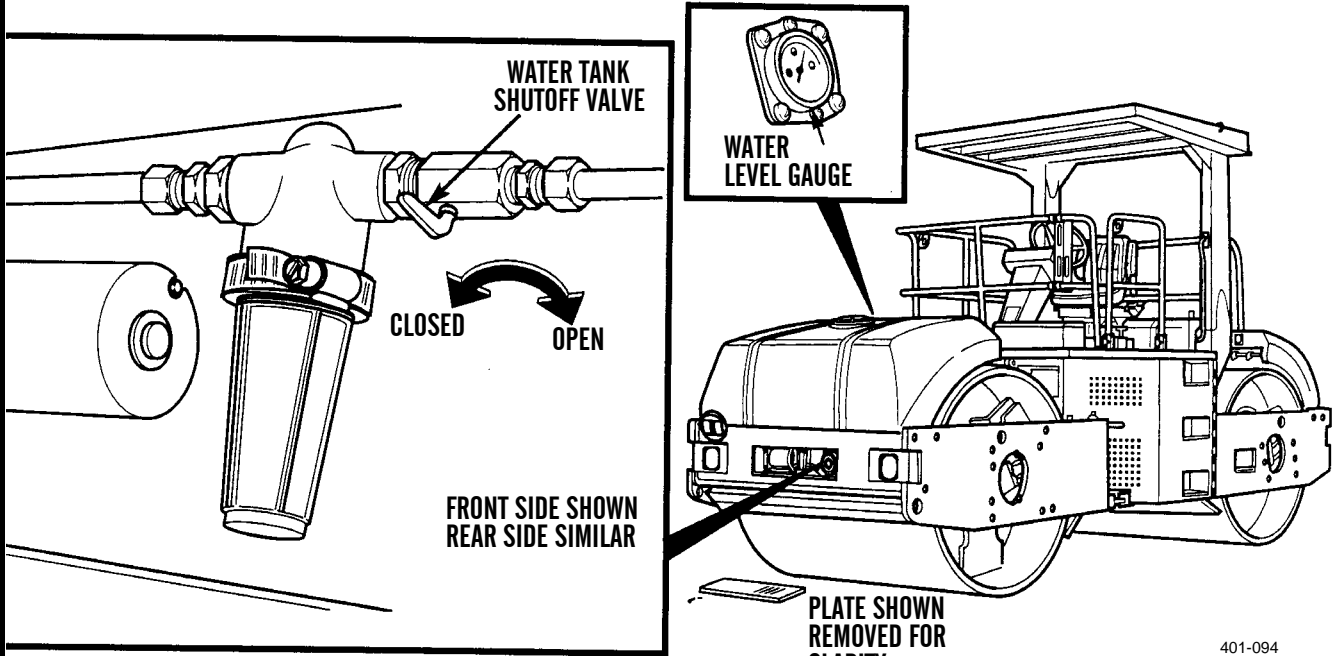
MALFUNCTION	TEST OR INSPECTION	CORRECTIVE ACTION
WATER SPRAY SYSTEM - CONTINUED		
<p>41. Water Consumption is Unequal Between Tanks.</p> 	<p>1. On CB534B, check that the water tank shutoff valve at the non-operating tank is open. Valve handle will be in line with the valve when the valve is open.</p>	<p>a. If water tank shutoff valve is not open, open valve. b. If water tank shutoff valve is open, go to Step 2.</p>
<p>42. Nozzle Spray Pattern is Inconsistent.</p>	<p>2. Check for pinched or damaged water lines.</p> <p>3. Check and service water spray nozzles (WP 0025 00).</p> <p>Check and service water spray nozzles (WP 0025 00).</p>	<p>a. If a water line(s) is damaged, component is faulty, notify supervisor. b. If water lines are not damaged, fault is not corrected. Notify supervisor.</p> <p>If malfunction continues, fault is not corrected. Notify supervisor.</p> <p>If malfunction continues, fault is not corrected. Notify supervisor.</p>

END OF WORK PACKAGE

CHAPTER 4
OPERATOR MAINTENANCE INSTRUCTIONS

GENERAL

1. To ensure that the CB534B and CB534C Rollers, Motorized, Vibrating Tandem Steel Drums are ready for operation at all times, they must be inspected on a regular basis so that defects may be found and corrected before they result in injury or equipment failure or damage.
2. The PMCS Table in WP 0012 00 contains systematic instructions on inspections, lubrications, services, adjustments and corrections to be performed by the operator to keep the roller in good operating condition and ready for its primary mission.

EXPLANATION OF TABLE ENTRIES

1. **Item Number (Item No.) Column.** Numbers in this column are for reference. When completing DA Form 2404 or DA Form 5988-E (*Equipment Inspection and Maintenance Worksheet*), include the item number for the check/service indicating a fault. Item numbers also appear in the order that you must perform checks and services for the interval listed.
2. **Interval Column.** This column tells you when you must perform the procedure in the procedure column.
 - a. *Before* procedures must be done immediately before you operate the roller.
 - b. *During* procedures must be done while you are operating the roller.
 - c. *After* procedures must be done immediately after you have operated the roller.
 - d. *Weekly* procedures must be done once each week.
 - e. *Monthly* procedures must be done once each month.
3. **Man-Hours Column.** This column indicates man-hours required to complete prescribed lubrication.
4. **Location, Item to Check/Service Column.** This column provides the location and item to be checked or serviced.

NOTE

The WARNINGS and CAUTIONS appearing in your PMCS table should always be observed. WARNINGS and CAUTIONS appear before applicable procedures. You must observe these WARNINGS to prevent injury to yourself and others, and CAUTIONS to prevent the roller from being damaged.

5. **Procedure Column.** This column gives the procedure you must perform to check or service the item listed in the Item to Check/Service column, to know if the roller is ready or available for its intended mission. You must perform the procedure at the time stated in the interval column.
6. **Not Fully Mission Capable If: Column.** Information in this column tells you what faults will keep the roller from being capable of performing its primary mission. If you perform check/service procedures that show faults listed in this column, the equipment is not mission-capable. Follow standard operating procedures for maintaining the equipment or reporting equipment failure.

GENERAL PMCS PROCEDURES

1. Always perform PMCS in the same order so it gets to be a habit. Once you've had some practice, you'll spot anything wrong in a hurry. If the roller does not perform as required, refer to the appropriate troubleshooting procedure in Chapter 3.
2. If anything looks wrong and you can't fix it, write it on your DA Form 2404 or DA Form 5988-E. If you find something seriously wrong, IMMEDIATELY report it to supervisor.
3. Before performing preventive maintenance, read all the checks required for the applicable interval and prepare all that is needed to make all the checks. You'll always need a rag (Item 16, WP 0029 00) or two.

OPERATOR PREVENTIVE MAINTENANCE CHECKS AND SERVICES (PMCS) INTRODUCTION - CONTINUED

0011 00

GENERAL PMCS PROCEDURES - CONTINUED**WARNING**

Cleaning compound, solvent MIL-PRF-680 Type III is an environmentally compliant and low toxic material. However, it may be irritating to the eyes and skin. Use protective gloves and goggles. Use in well-ventilated areas. Keep away from open flames and other sources of ignition.

- a. **Keep It Clean.** Dirt, grease, oil and debris get in the way and may cover up a serious problem. Clean as you work and as needed. Use cleaning compound, solvent (Item 3, WP 0029 00) on all metal surfaces. Use detergent (Item 5, WP 0029 00) and water when you clean rubber, plastic and painted surfaces.

**WARNING**

When servicing roller, performing maintenance or disposing of materials such as engine coolant, hydraulic fluid, lubricants, battery acids or batteries and CARC paint, consult your Field/local hazardous waste disposal center or safety office for local regulatory guidance. If further information is needed, please contact The Army Environmental Hotline at 1-800-872-3845.

- b. **Hazardous Waste Disposal.** Ensure all spills are cleaned up and disposed of IAW local policy and ordinances.
- c. **Rust and Corrosion.** Check metal parts for rust and corrosion. If any bare metal or corrosion exists, clean and apply a light coat of lubricating oil (Item 13, WP 0029 00). Report it to supervisor.
- d. **Bolts, Nuts and Screws.** Check bolts, nuts and screws for obvious looseness, missing, bent or broken condition. You can't try them all with a tool, but look for chipped paint, bare metal or rust around bolt heads. If you find one is loose, notify supervisor.
- e. **Welds.** Look for loose or chipped paint, rust or gaps where parts are welded together. If you find a bad weld, report it to supervisor.
- f. **Electric Wires and Connectors.** Look for cracked or broken insulation, bare wires and loose or broken connectors. Reconnect loose connectors. Ensure that wires are in good condition.
- g. **Hoses and Fluid Lines.** Look for wear, damage and signs of leaks. Check for loose clamps and fittings. Wet spots indicate leaks, but a stain around a fitting or connector can also mean a leak. If a leak comes from a loose fitting or connector, notify supervisor. If something is broken or worn out, report it to supervisor.
- h. **Fluid Leakage.** It is necessary for you to know how fluid leakage affects the status of the roller. The following are definitions of the types/classes of leakage you need to know to be able to determine the status of the roller. Learn and be familiar with them, and remember - when in doubt, notify supervisor.

CAUTION

Operation is allowable with Class I and Class II leakage, EXCEPT for fuel, where NO leaks are allowed. WHEN IN DOUBT, NOTIFY SUPERVISOR. When operating with Class I or Class II leaks, check fluid levels more frequently. Class III leaks must be reported immediately to supervisor. Failure to do this will result in damage to roller and/or components.

OPERATOR PREVENTIVE MAINTENANCE CHECKS AND SERVICES (PMCS) INTRODUCTION - CONTINUED

0011 00

GENERAL PMCS PROCEDURES - CONTINUED**NOTE**

Notify supervisor of any leaks you cannot fix.

Leakage Definitions for PMCS

Class I	Leakage indicated by wetness or discoloration, but not great enough to form drops.
Class II	Leakage great enough to form drops, but not enough to cause drops to drip from the item being checked/inspected.
Class III	Leakage great enough to form drops that fall from the item being checked/inspected.

GENERAL LUBRICATION PROCEDURES**NOTE**

- Lubrication instructions contained in this PMCS are MANDATORY.
 - Overall view of lubrication points is located in the Lubrication Chart at the end of this work package. Localized views are located following the Lubrication Chart. Specific lubrication instructions are contained in the PMCS Table in WP 0012 00.
 - The roller is enrolled in the Army Oil Analysis Program (AOAP) for sampling of engine and hydraulic system oil.
 - Refer to FM 9-207 for lubrication in arctic operation.
1. Included in this PMCS are lubrication services to be performed by the operator.
 2. Lubrication intervals are based on normal operation. Lubricate more during constant use and less during inactive periods. Use correct grade of lubricant for seasonal temperature expected. Refer to the *KEY* at the end of this work package.
 3. For roller under manufacturer's warranty, hardtime intervals shall be followed. Shorten intervals if lubricants are known to be contaminated or if operation is under adverse conditions (e.g., longer than usual operating hours, extended idling periods, extreme dust, etc.).
 4. Keep all lubricants in a closed container and store in a clean, dry place away from extreme heat. Keep container covers clean and do not allow dust, dirt or other foreign material to mix with lubricants. Keep lubrication equipment clean and ready for use.

**WARNING**

Cleaning compound, solvent MIL-PRF-680 Type III is an environmentally compliant and low toxic material. However, it may be irritating to the eyes and skin. Use protective gloves and goggles. Use in well-ventilated areas. Keep away from open flames and other sources of ignition.

5. Clean area around lubrication points with cleaning compound, solvent (Item 3, WP 0029 00) or equivalent before lubricating equipment. Keep all external parts of equipment not requiring lubrication free of lubricants. After lubrication, wipe off excess lubricant to prevent accumulation of foreign matter.
6. Maintain a record of lubrication performed and report any problems noted during lubrication. Refer to DA Pam 738-750 for forms and procedures to record and report any findings.

OPERATOR PREVENTIVE MAINTENANCE CHECKS AND SERVICES (PMCS) INTRODUCTION - CONTINUED

0011 00

GENERAL LUBRICATION PROCEDURES - CONTINUED

NOTE

Only lubricants authorized for use by the operator are listed in this KEY.

- KEY -

LUBRICANT/ COMPONENT	REFILL CAPACITY	EXPECTED TEMPERATURES*			INTERVALS
		Above +15°F (Above -9°C)	+40°F to -15°F (+4°C to -26°C)	+40°F to -65°F (+4°C to -54°C)	
OE/HDO Lubricating Oil, ICE, Tactical Service (MIL-PRF-2104)					D - Daily W - Weekly M - Monthly
OEA-30 Lubricating Oil, ICE, Arctic (MIL-PRF-46167)					
Engine Crankcase	2.3 gal. (9 l)	OE/HDO - 15/40	OE/HDO-10	OEA-30	
Hydraulic Oil Tank	15.5 gal. (59 l), CB534B Roller 24 gal. (91 l), CB534C Roller	OE/HYDO-10	OE/HYDO-10	OEA-30	
GAA Grease, Automotive and Artillery					
Front and Rear Ring Bearings	As Req'd				
SO Synthetic Oil ISO 220					
Front and Rear Vibratory Bearing Reservoirs	3.1 gal. (12 l)	All Temperatures			
GO Lubricating Oil, (MIL-PRF-2105)					
Front Propel Gearbox	0.5 gal. (2 l)	GO 75	GO 75	GO 80W/90	
Rear Propel Gearbox	0.6 gal. (2.4 l)	GO 75	GO 75	GO 80W/90	

GENERAL LUBRICATION PROCEDURES - CONTINUED

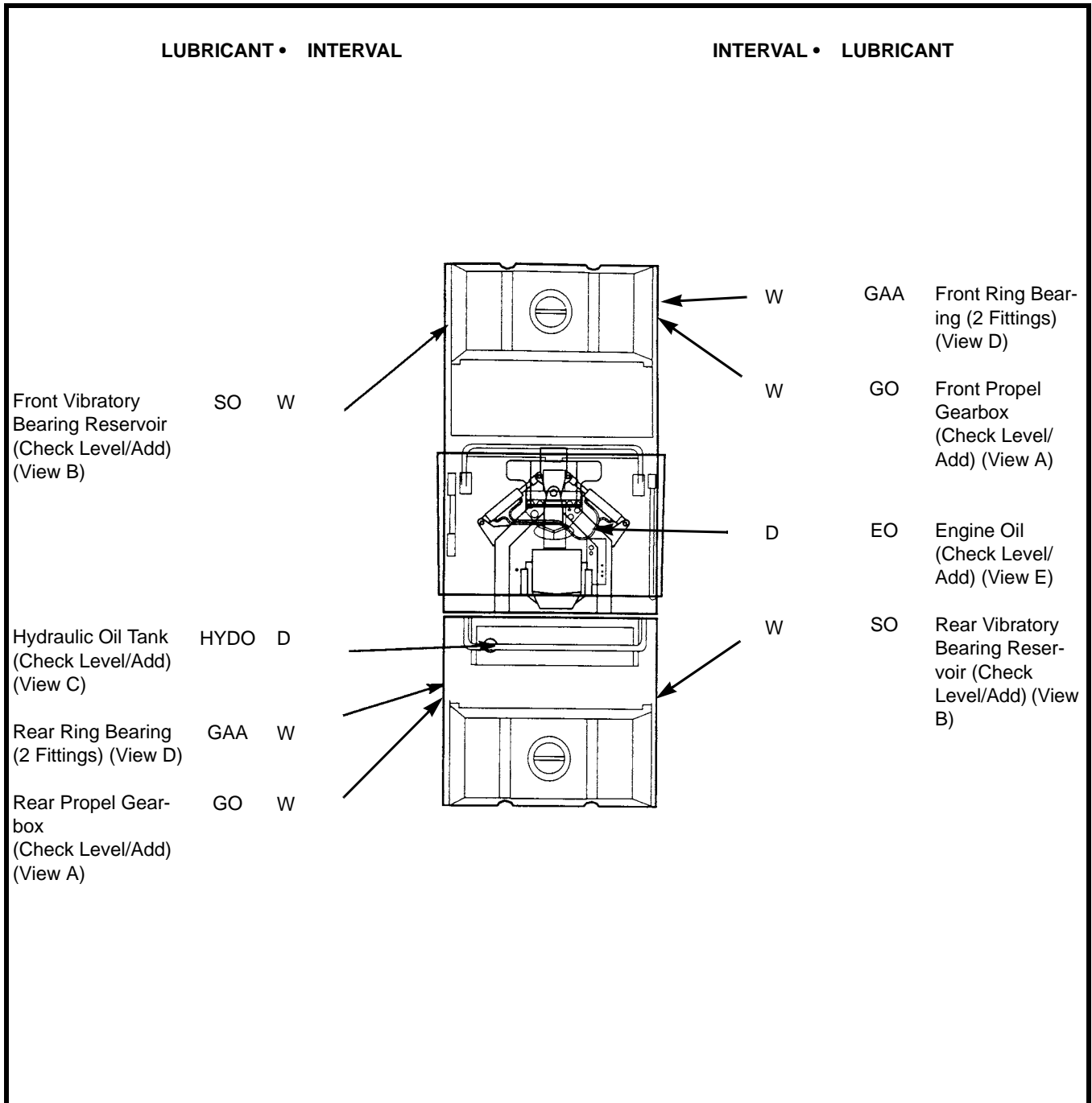

GENERAL LUBRICATION PROCEDURES - CONTINUED

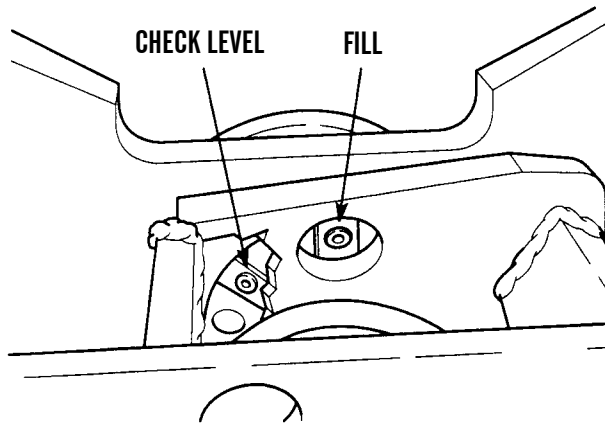

VIEW A - PROPEL GEARBOX (FRONT AND REAR)

401-126

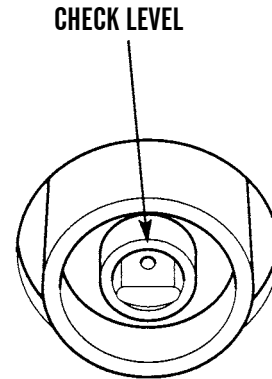

401-127

VIEW B - VIBRATORY BEARING RESERVOIR (FRONT AND REAR)

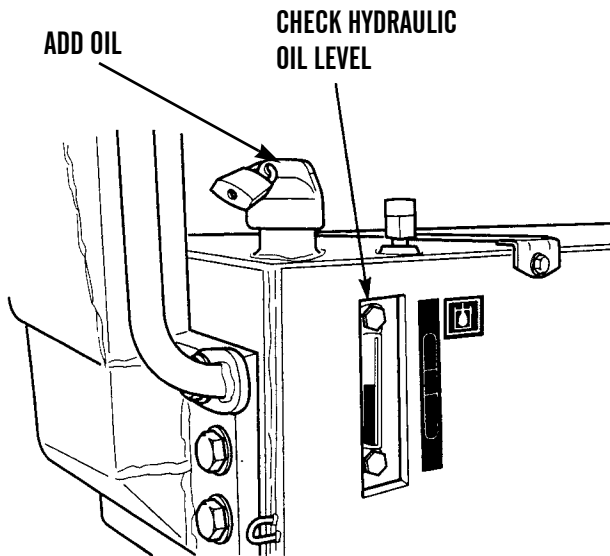

VIEW C - HYDRAULIC OIL TANK

401-128

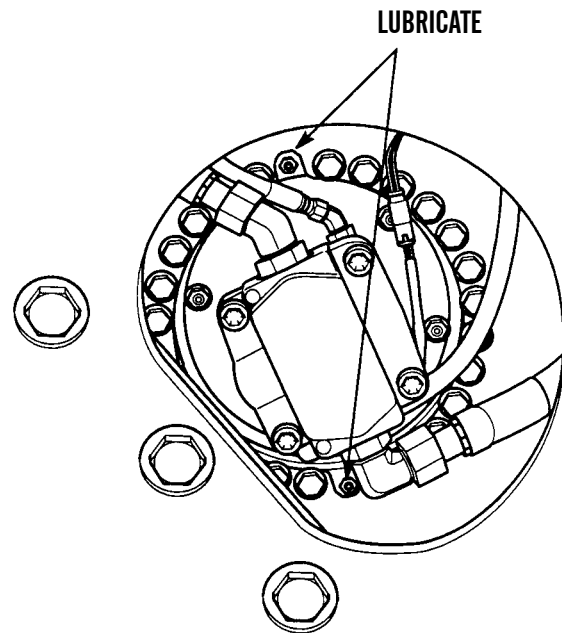

VIEW D - RING BEARING (FRONT AND REAR)

401-129

GENERAL LUBRICATION PROCEDURES - CONTINUED

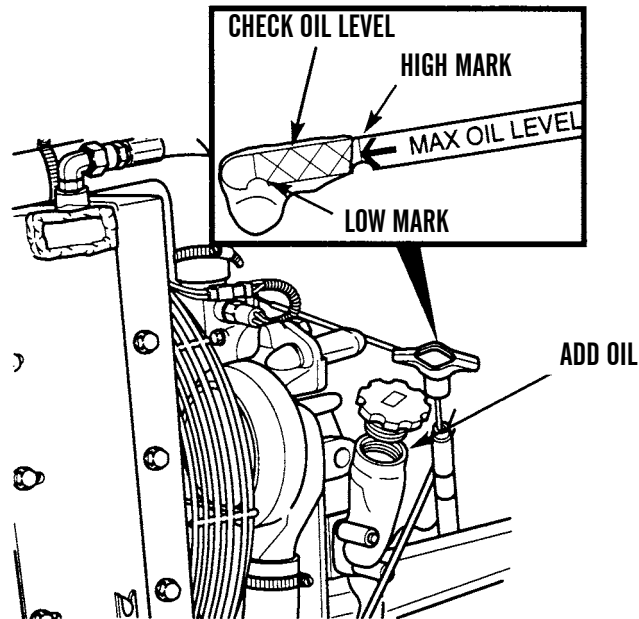

VIEW E - ENGINE OIL CHECK AND SERVICE

401-130

END OF WORK PACKAGE

Table 1. Operator Preventive Maintenance Checks and Services (PMCS) for DSWR.

ITEM NO.	INTERVAL	MAN-HOURS	LOCATION	ITEM TO CHECK/SERVICE	PROCEDURE	NOT FULLY MISSION CAPABLE IF:
1	Before		Exterior of Roller		<p style="text-align: center;">NOTE</p> <ul style="list-style-type: none"> • Review all WARNINGS, CAUTIONS and NOTES before performing Operator PMCS on the roller. • Perform all weekly and before operation PMCS checks if: <ul style="list-style-type: none"> a. You are the assigned operator but have not operated the roller since the last weekly checks. b. You are operating the roller for the first time. • Unless otherwise indicated, perform all lubrication and preventive maintenance with roller parked on level ground, transmission in N (NEUTRAL) with transmission lock lever in locked position, brake lock lever engaged, implements lowered to the ground and engine shut down. • Assistance from Field Maintenance is required to perform lubrication services. • The CB534B Roller is illustrated unless otherwise noted. <p>a. Look under roller for signs of fluid leakage (fuel, oil and coolant).</p> <p>b. Check warning and data labels for damage, cleanliness and readability.</p>	<p>Any leakage of fuel or Class III leakage of oil or coolant is found.</p> <p>Any WARNING labels are missing or damaged beyond readability.</p>

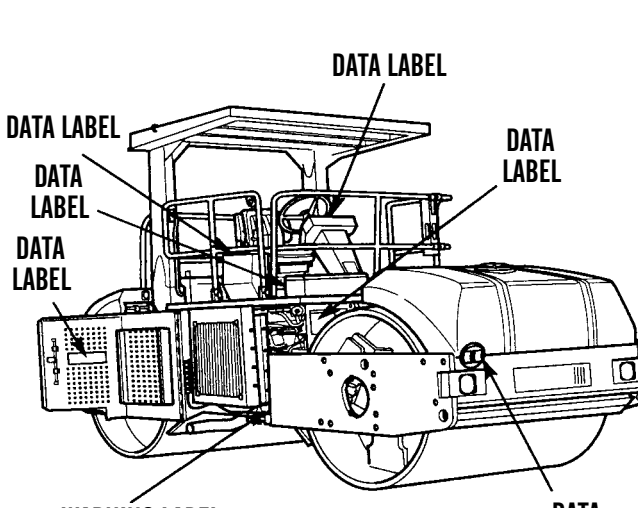
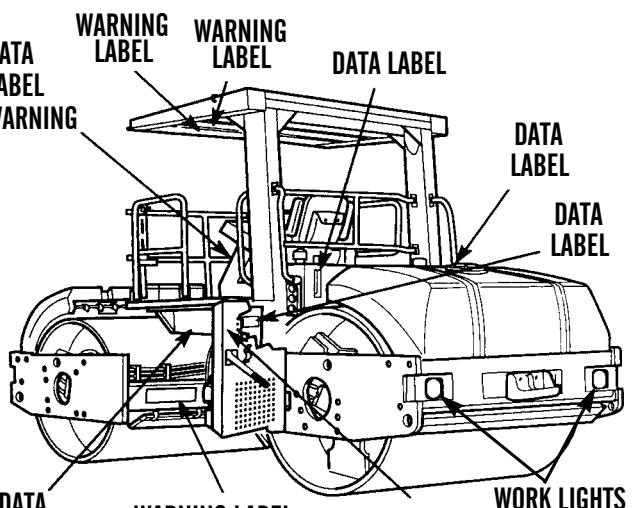
401-018

Table 1. Operator Preventive Maintenance Checks and Services (PMCS) for DSWR - Continued.

ITEM NO.	INTERVAL	MAN-HOURS	LOCATION ITEM TO CHECK/ SERVICE	PROCEDURE	NOT FULLY MISSION CAPABLE IF:
2	Before		Work Lights	Check front work lights for broken lenses.	
3	Before		Engine Left Side	a. Open left-side door assembly (WP 0005 00). b. Check rear of engine for accumulated grease/oil.	Excessive accumulation of grease/oil is found.
4	Before		Electrical Wires	Check for loose or frayed wires and loose connections.	Wires are frayed or loose or connectors are loose.
5	Before		Hydraulic Hoses	Check for crimped, torn or damaged hydraulic hoses.	Hydraulic hoses are crimped, torn or damaged.
6	Before		Air Filter Service Indicator	Check indicator viewing window and arrow while engine is shut off. If red color is in view in window and arrow is at 22 in. position, service air cleaner (WP 0010 00).	Red color appears in viewing window/arrow is at 22 in. position.

AIR FILTER SERVICE INDICATOR

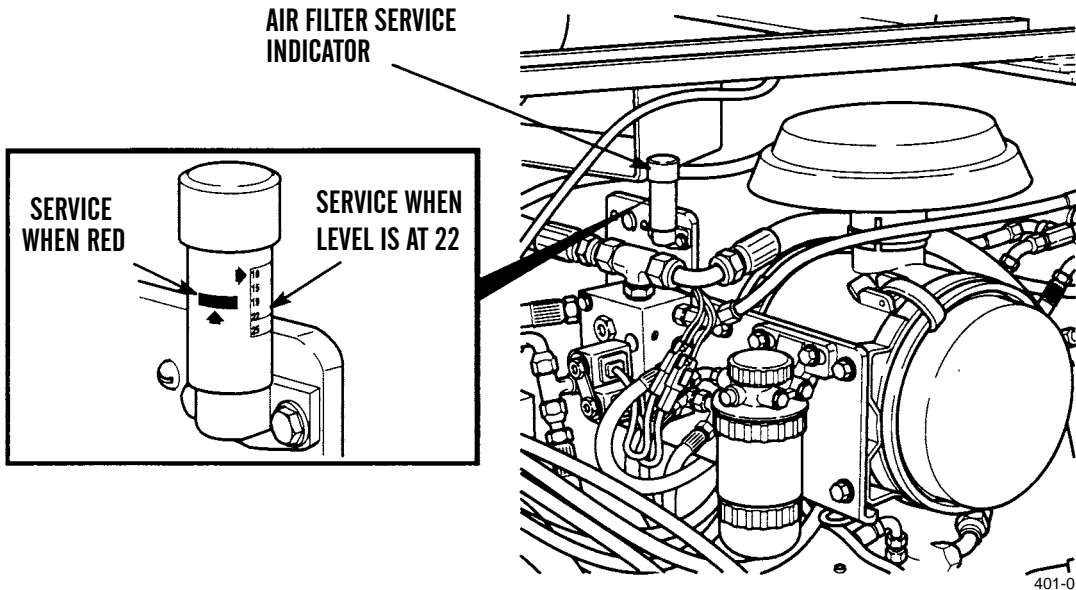

Table 1. Operator Preventive Maintenance Checks and Services (PMCS) for DSWR - Continued.



ITEM NO.	INTERVAL	MAN-HOURS	LOCATION ITEM TO CHECK/ SERVICE	PROCEDURE	NOT FULLY MISSION CAPABLE IF:
6 (Con't)	Before		Air Filter Service Indicator		
					
7	Before	0.1 Hours	Fuel/Water Separator (Primary)	<div style="text-align: center;">  <p>WARNING</p> <p>DO NOT perform fuel/water separator checks, inspections or draining while smoking, or when near fire or sparks. Fuel may ignite, causing injury, death or damage to roller.</p> <p>CAUTION</p> <p>Operation of roller with damaged fuel/water separator can cause engine damage.</p> </div> <ol style="list-style-type: none"> a. Check fuel/water separator for leaks or damage such as cracks. b. Place container with minimum 1 qt (1 l) capacity under fuel/water separator. c. Open drain valve and drain fluid until only fuel comes out. Close drain valve. d. Dispose of drained fluids in accordance with local regulations. 	Any leakage from fuel/water separator is evident that fuel/water separator is damaged.

Table 1. Operator Preventive Maintenance Checks and Services (PMCS) for DSWR - Continued.

ITEM NO.	INTERVAL	MAN-HOURS	LOCATION ITEM TO CHECK/ SERVICE	PROCEDURE	NOT FULLY MISSION CAPABLE IF:
7 (Con't)	Before	0.1 Hours	Fuel/Water Separator (Primary)	e. Close left-side door assembly (WP 0005 00). NOTE <ul style="list-style-type: none"> Hydraulic oil is checked cold and warm. Roller must be on level surface to have accurate level reading. 	
8	Before	0.2 Hours	Hydraulic Oil Level (Cold Oil Check)	Check that hydraulic oil level is between the high and low marks on the label beside the hydraulic oil tank sight gauge. If level is below "LOW" level mark, fill hydraulic tank with hydraulic oil (WP 0019 00).	
9.1	Before		Rear Water Tank	Check level of water as indicated in water level gauge. Ensure tank is full before operating roller (WP 0024 00).	
9	Before		Work Lights	Check rear work lights for broken lenses.	

The diagram shows a side view of a hydraulic oil tank assembly. A padlock is shown locking the tank fill cap. Below the cap is a sight gauge with a label indicating the high and low oil levels. The label is a vertical strip with a 'U' symbol at the top and two horizontal lines representing the 'LOW' and 'HIGH' marks.

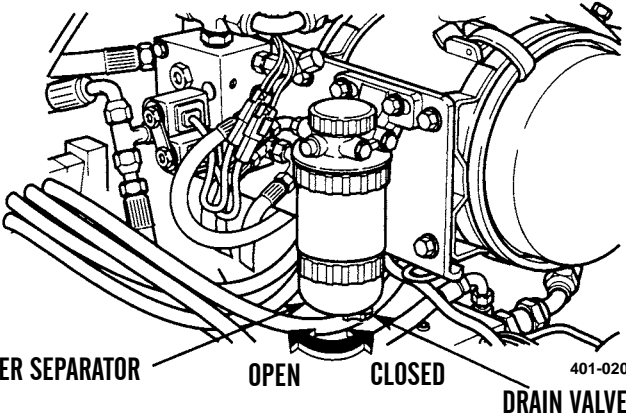
401-024

Table 1. Operator Preventive Maintenance Checks and Services (PMCS) for DSWR - Continued.

ITEM NO.	INTERVAL	MAN-HOURS	LOCATION ITEM TO CHECK/ SERVICE	PROCEDURE	NOT FULLY MISSION CAPABLE IF:
9 (Con't)	Before		Work Lights		
					
10	Before		Engine Right Side	a. Open right-side door assembly (WP 0005 00). b. Check front of engine for accumulated grease/oil.	Excessive accumulation of grease/oil is found.
11	Before		Radiator	Check radiator for damage, signs of leakage, and debris that can restrict air flow.	Class III coolant leaks are evident. Radiator is damaged or debris is restricting air flow.
12	Before		Electrical Wires	Check for loose or frayed wires and loose connectors.	Wires are frayed or loose or connectors are loose.
13	Before		Hydraulic Hoses	Check for crimped, torn, or damaged hydraulic hoses.	Hydraulic hoses are crimped, torn, or damaged.
14	Before	0.2 Hours	Engine Oil Level	Check engine oil level. If engine oil level is low, add oil (WP 0014 00).	Engine oil level is low.

Table 1. Operator Preventive Maintenance Checks and Services (PMCS) for DSWR - Continued.

ITEM NO.	INTERVAL	MAN-HOURS	LOCATION ITEM TO CHECK/ SERVICE	PROCEDURE	NOT FULLY MISSION CAPABLE IF:
15	Before	0.1 Hours	Fuel/Water Separator (Secondary) (CB534C Only)	 <p>WARNING</p> <p>DO NOT perform fuel/water separator checks, inspections or draining while smoking, or when near fire or sparks. Fuel may ignite, causing injury, death or damage to roller.</p> <p>a. Check fuel/water separator for leaks or damage such as cracks.</p> <p>b. Place container with minimum 1 qt (1l) capacity under fuel/water separator.</p> <p>c. Open drain valve and drain fluid until only fuel comes out. Close drain valve.</p> <p>d. Dispose of drained fluid in accordance with local regulations.</p>	Any leakage from fuel/water separator is evident or fuel/water separator is damaged.
16	Before		V-Belts	Check for damaged or missing V-belts.	Any V-belt is loose, missing, broken, greasy, peeling, glazed, cracked to the belt fiber, has more than one crack (1/8 in. in depth or 50% or belt thickness), or has frays more than 2 in. long.

Table 1. Operator Preventive Maintenance Checks and Services (PMCS) for DSWR - Continued.

ITEM NO.	INTERVAL	MAN-HOURS	LOCATION ITEM TO CHECK/ SERVICE	PROCEDURE	NOT FULLY MISSION CAPABLE IF:
16 (Con't)	Before		V-Belts	 <p>The diagrams show various V-belt conditions: 1. CRACKED/SPLIT: A V-belt with several deep, vertical cracks across its width. 2. GREASY: A V-belt with a thick, irregular layer of grease coating its surface. 3. GLAZED: A V-belt with a smooth, shiny, and somewhat uneven surface layer. 4. PEELING: A V-belt with large sections of its outer surface missing or peeling away, exposing the inner cords.</p>	
17	Before		Water Pump	<p>Check for coolant leakage at radiator hoses and water pump.</p> <ol style="list-style-type: none"> A small amount of coolant leakage across the surface of the water pump seals is normal. This leakage is required in order to provide lubrication for this type of seal. A hole is provided in the water pump housing in order to allow this coolant/seal lubricant to drain from the pump housing. Intermittent leakage of small amounts of coolant from this hole indicates normal operation. It is not an indication of water pump seal failure or a faulty water pump. 	Class III coolant leaks are evident.

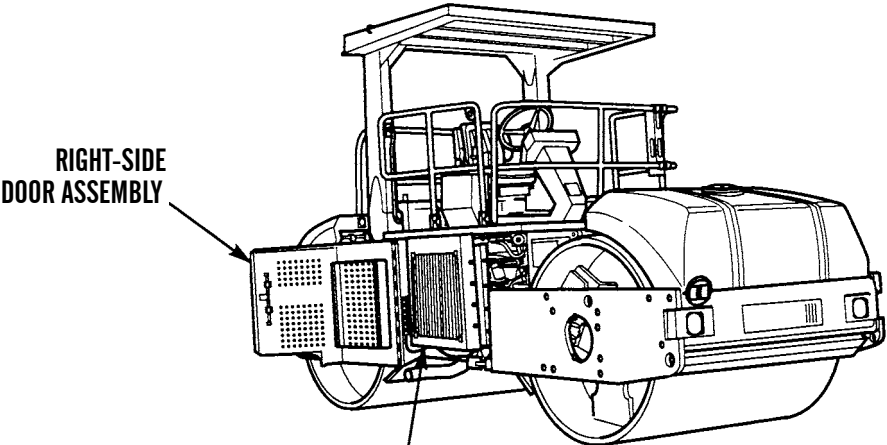
401-022

Table 1. Operator Preventive Maintenance Checks and Services (PMCS) for DSWR - Continued.

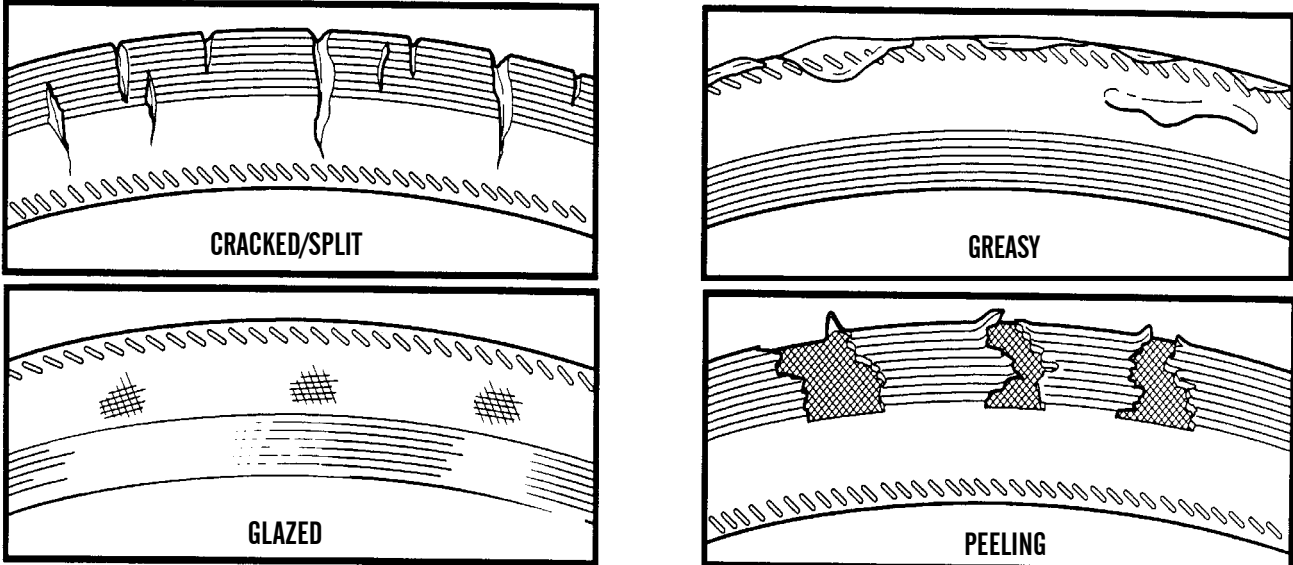

ITEM NO.	INTERVAL	MAN-HOURS	LOCATION ITEM TO CHECK/ SERVICE	PROCEDURE	NOT FULLY MISSION CAPABLE IF:
18	Before		Coolant	<p>a. Pull lever, on underside of operator platform, back and open access cover on operator platform. Release lever.</p> <div style="text-align: center;">   <p>WARNING</p> </div> <ul style="list-style-type: none"> • DO NOT service cooling system unless engine has cooled. This is a pressurized cooling system and escaping steam or hot coolant may cause burns. • DO NOT remove radiator cap when engine is hot. Allow engine to cool down. Loosen cap to first stop and let any pressure out of cooling system, then remove cap. Failure to follow this warning may cause burns. • Wear effective eye, glove, and skin protection when handling coolants. Failure to do so may cause injury. 	
					
				<p>b. Slowly open radiator fill cap by turning cap to the left until pressure starts to release from radiator. Wait until pressure is fully released before removing cap.</p> <p>c. Check that coolant level is approximately 3 in. (7.6 cm) below fill port. If coolant level is low, add coolant (WP 0017 00).</p>	Coolant level is low.

Table 1. Operator Preventive Maintenance Checks and Services (PMCS) for DSWR - Continued.

ITEM NO.	INTERVAL	MAN-HOURS	LOCATION	PROCEDURE	NOT FULLY MISSION CAPABLE IF:
18 (Con't)	Before		Coolant	d. Install radiator cap on radiator. Turn cap clockwise until tight. e. Pull lever back and close access cover on operator's platform. Release lever. f. Close right-side door assembly (WP 0005 00).	
19	Before		Steering Frame Lock Pin	Check that steering frame lock pin is in unlocked position. If steering frame lock pin is in locked position, unlock steering frame (WP 0005 00).	

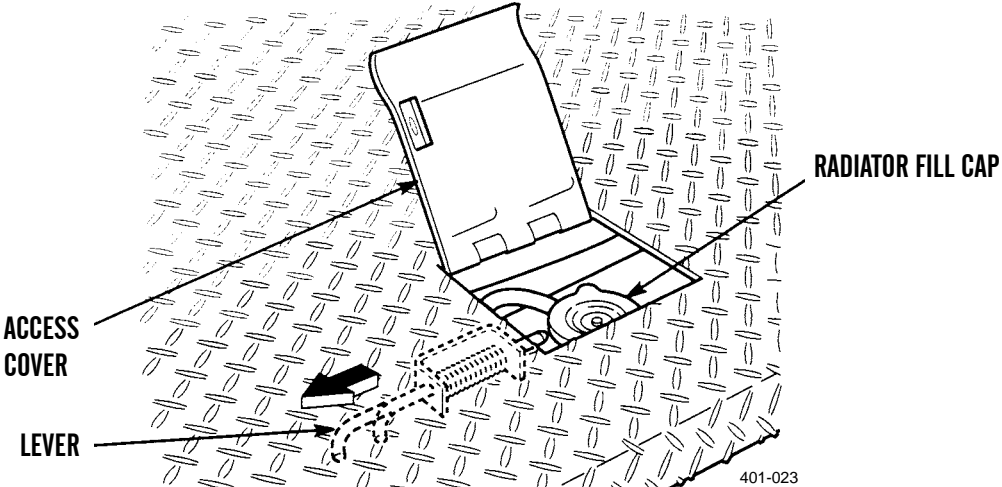
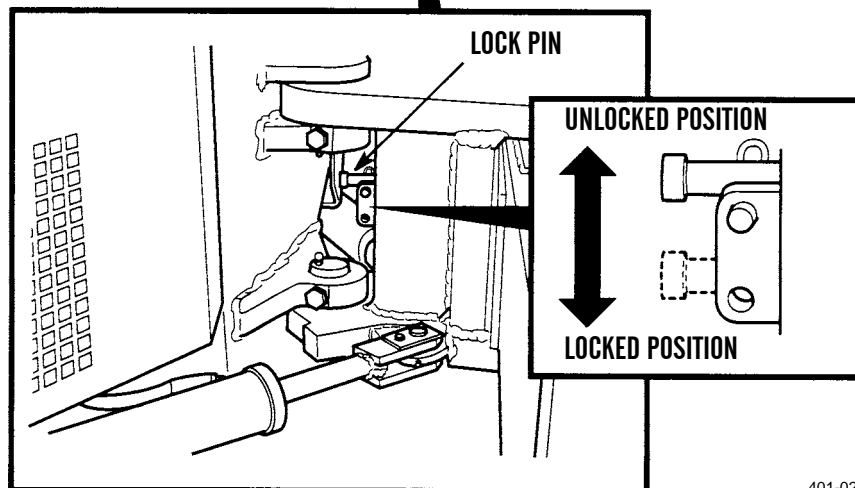
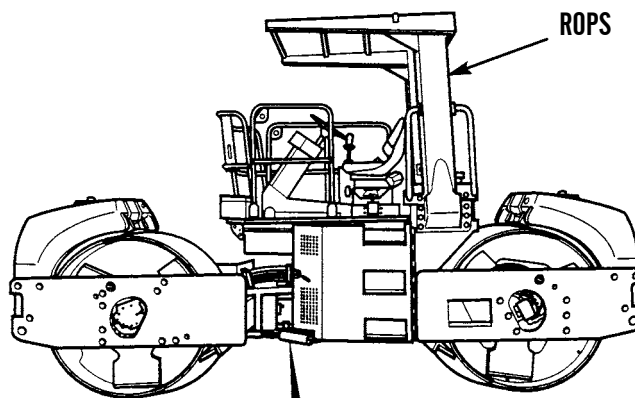

401-025

Table 1. Operator Preventive Maintenance Checks and Services (PMCS) for DSWR - Continued.

ITEM NO.	INTERVAL	MAN-HOURS	LOCATION	ITEM TO CHECK/SERVICE	PROCEDURE	NOT FULLY MISSION CAPABLE IF:
20	Before			Driver Safety Canopy (Rollover Protective Structure [ROPS])	Check that ROPS is properly installed. Check ROPS for damage such as cracks, holes, or broken welds, and loose or missing mounting bolts.	Mounting bolts are loose or missing or ROPS is damaged or missing.
21	Before			Front Water Tank	Check level of water as indicated in water level gauge. Ensure tank is full before operating roller (WP 0024 00).	
22	Before			Warning and Indicator Lights and Warning Horn	<p>a. Turn on battery disconnect switch (WP 0004 00) and insert key in engine start switch.</p> <p>NOTE Do NOT allow engine to start during this check.</p> <p>b. Turn engine start switch to ON position and observe warning and indicator lights and warning horn.</p> <p>c. Return key to OFF position and remove key from engine start switch.</p>	Warning and indicator lights and warning horn do not function.

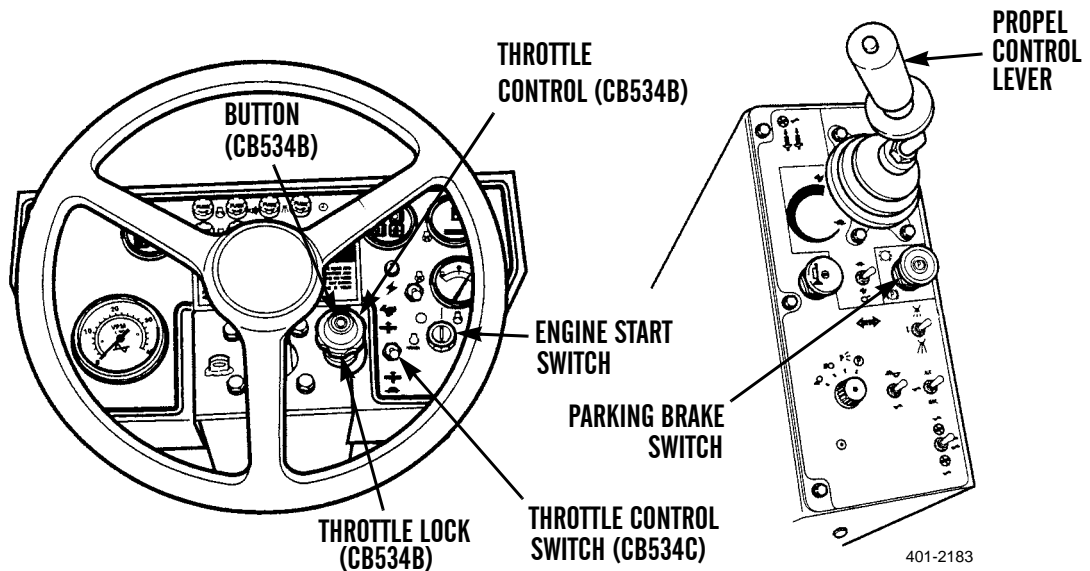

401-2183

Table 1. Operator Preventive Maintenance Checks and Services (PMCS) for DSWR - Continued.



ITEM NO.	INTERVAL	MAN-HOURS	LOCATION	ITEM TO CHECK/SERVICE	PROCEDURE	NOT FULLY MISSION CAPABLE IF:
23	Before		Operator Station	<p>a. Check that rotation lock operates freely and locks operator station in place (WP 0005 00).</p> <p style="text-align: center;">NOTE</p> <p>Operator station will not pivot full 180 degrees unless handrails are adjusted for operation.</p> <p>b. Check that operator station freely pivots 180 degrees (WP 0005 00).</p>	<p>Rotation lock is missing or will not lock in holes in operator platform.</p>	
24	Before		Neutral Start Switch	<p>a. Push propel control lever forward.</p> <p>b. Pull up on parking brake switch to release parking brake.</p> <p>c. Ensure that area is free of personnel and path of travel is clear.</p> <p>d. Position propel control lever in full forward position.</p> <p>e. Insert key in engine start switch.</p> <p style="text-align: center;">NOTE</p> <p>Do NOT allow engine to start during this check.</p> <p>f. Hold engine start switch key in START position while slowly moving propel control lever to full back (REVERSE) and then to center (NEUTRAL/STOP) position. Turn engine start switch to OFF position.</p>	<div style="display: flex; justify-content: space-around; align-items: center;">  <div style="text-align: center;"> <p>WARNING</p> <ul style="list-style-type: none"> Your hearing can be PERMANENTLY DAMAGED if you are exposed to constant high noise levels of 85 DB or greater. Hearing protection is required when operating roller or when working on roller while it is operating. Failure to wear hearing protection may result in hearing loss. Ensure area around the roller is clear of personnel before starting engine. Failure to follow this warning may cause injury or death. </div>  </div> <p>Engine attempts to start before control lever is in NEUTRAL position.</p>	

Table 1. Operator Preventive Maintenance Checks and Services (PMCS) for DSWR - Continued.

ITEM NO.	INTERVAL	MAN-HOURS	LOCATION ITEM TO CHECK/ SERVICE	PROCEDURE	NOT FULLY MISSION CAPABLE IF:
25	Before		Throttle Control (CB534B)	Turn throttle lock counterclockwise, press and hold button down, and pull throttle control fully up and fully down, checking for free movement without sticking or binding. Release button.	Throttle control movement is not free.
26	Before		Gauges and Warning Indicators	<p>a. Start engine (WP 0005 00).</p> <p>b. Check that warning lights and warning horn go off within 15 seconds. If warning lights and warning horn do not go off within 15 seconds, shut engine off immediately and notify supervisor.</p> <p>c. Ensure fuel level gauge indicates adequate fuel for the mission. Refuel if required (WP 0015 00).</p>	Any warning light or horn stays on for more than 15 seconds after startup or comes on during operation.

Table 1. Operator Preventive Maintenance Checks and Services (PMCS) for DSWR - Continued.

ITEM NO.	INTERVAL	MAN-HOURS	LOCATION ITEM TO CHECK/ SERVICE	PROCEDURE	NOT FULLY MISSION CAPABLE IF:
26 (Con't)	Before		Gauges and Warning Indicators		
27	Before		Propel Control Lever/ Backup Alarm	<p>a. With parking brake off (parking brake switch pulled up), check that propel control lever operates smoothly without sticking or binding in forward and reverse positions.</p> <p>b. Check that backup alarm sounds when propel control lever is placed in reverse position.</p>	<p>Propel control lever does not operate in forward or reverse positions.</p> <p>Backup alarm does not sound.</p>
28	Before		Horn	Check that horn sounds when horn switch is pressed.	
29	Before		Work Lights	Move lights switch through all positions and check that front and rear work lights illuminate.	Work lights do not illuminate during low light or night operation.

Table 1. Operator Preventive Maintenance Checks and Services (PMCS) for DSWR - Continued.

ITEM NO.	INTERVAL	MAN-HOURS	LOCATION ITEM TO CHECK/ SERVICE	PROCEDURE	NOT FULLY MISSION CAPABLE IF:
30	Before		Vibration System	<p style="text-align: center;">WARNING</p> <p>Do not turn vibratory system on while roller is standing still on a very solid surface. A loss of steering can be experienced which could result in injury.</p> <p>a. Move vibration control switch to automatic (AUTO) mode and amplitude select switch to low pitch mode. Turn vibratory push switch to ON (vibratory system indicator light should illuminate).</p> <p>b. Move roller forward (WP 0005 00).</p> <p>c. Check that vibration per minute (VPM) tachometer is working when vibratory system is engaged.</p> <p>d. Press vibration push switch to stop vibration. Move the amplitude select switch to high pitch mode. Press vibration push switch to start vibration.</p> <p>e. Move the drum select switch to forward (front drum), center (both), and rear (rear drum).</p> <p>f. Move vibration control switch to manual (MAN) mode.</p> <p>g. Press vibration push switch to turn on the vibration system (vibratory system indicator light should illuminate).</p>	<p>Vibratory system has not activated when roller travel is close to full speed.</p> <p>Vibratory system does not operate in both high and low pitch modes.</p> <p>Vibratory system does not operate in front, both, and rear drums.</p> <p>Vibratory system does not activate.</p>

Table 1. Operator Preventive Maintenance Checks and Services (PMCS) for DSWR - Continued.

ITEM NO.	INTERVAL	MAN-HOURS	LOCATION	ITEM TO CHECK/SERVICE	PROCEDURE	NOT FULLY MISSION CAPABLE IF:
30 (Con't)	Before		Vibration System			
 <p>The diagram shows a top-down view of the DSWR control panel. On the left is a steering wheel with a central hub. To the right of the wheel is a control console with various gauges and switches. Two specific switches are highlighted with callouts: the 'PROPEL SPEED RANGE SWITCH' and the 'WATER SPRAY SWITCH'. The 'PROPEL SPEED RANGE SWITCH' is a rotary switch with 'LOW' and 'HIGH' positions. The 'WATER SPRAY SWITCH' is a push-button switch. The diagram is labeled with the number '401-030' at the bottom right.</p>						
31	Before		Propel Speed Range Switch	<p>a. Move propel speed range switch to low (tortoise) and the high (hare) positions.</p> <p>b. Press vibration push switch to turn off the vibration system and stop roller (WP 0004 00).</p>	<p>Propel system does not operate or change to low (tortoise) and high (hare) propel mode as switch is moved.</p>	
32	Before		Water Spray System	<p>Move water spray switch to intermittent (forward) position for 60 seconds and then to continuous (back) position for 10 seconds.</p>	<p>Water spray system does not operate or operates in intermittent or continuous mode only.</p>	

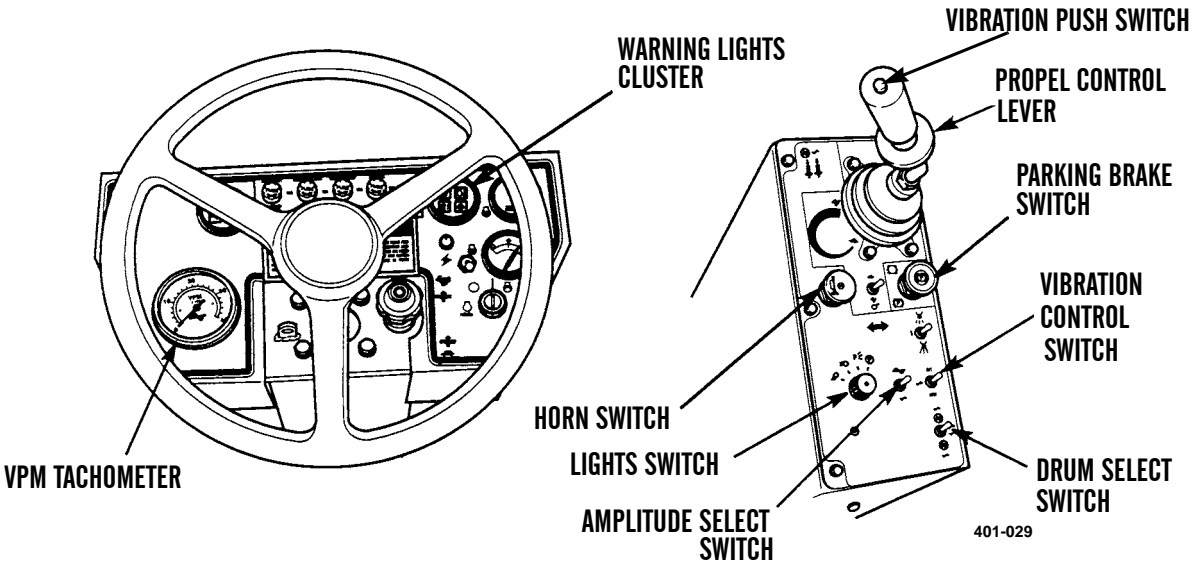
Table 1. Operator Preventive Maintenance Checks and Services (PMCS) for DSWR - Continued.

ITEM NO.	INTERVAL	MAN-HOURS	LOCATION	ITEM TO CHECK/SERVICE	PROCEDURE	NOT FULLY MISSION CAPABLE IF:
33	Before			Hydraulic Oil Filter (CB534B)	<p style="text-align: center;">WARNING</p> <p>Engine compartment contains a partially exposed fan blade. Use caution around front of engine if engine is running. Failure to comply may result in injury.</p> <p>a. Open right-side door assembly (WP 0005 00)</p> <p>b. With engine operating at high idle (throttle control near to or fully up), have assistant check that the white filter indicator is not in red zone. Notify supervisor if white filter indicator is in red zone.</p> <p>c. Close right-side door assembly (WP 0005 00).</p>	White filter indicator is in the red zone.
<div style="display: flex; align-items: center;">  <div style="margin-left: 20px;"> <p>FAN BLADE</p> <p>HYDRAULIC OIL FILTER INDICATOR</p> </div> <div style="margin-left: 20px; border: 1px solid black; padding: 5px;"> <p style="text-align: right;">CB534B ONLY</p> <p style="text-align: center;">RED ZONE</p>  <p style="text-align: center;">WHITE FILTER INDICATOR</p> </div> </div>						
34	Before		Engine	Check for excessive exhaust smoke, unusual engine noise, rough running or misfiring engine.	Excessive exhaust smoke, unusual engine noise, rough running or misfiring engine are noted.	

401-031

Table 1. Operator Preventive Maintenance Checks and Services (PMCS) for DSWR - Continued.

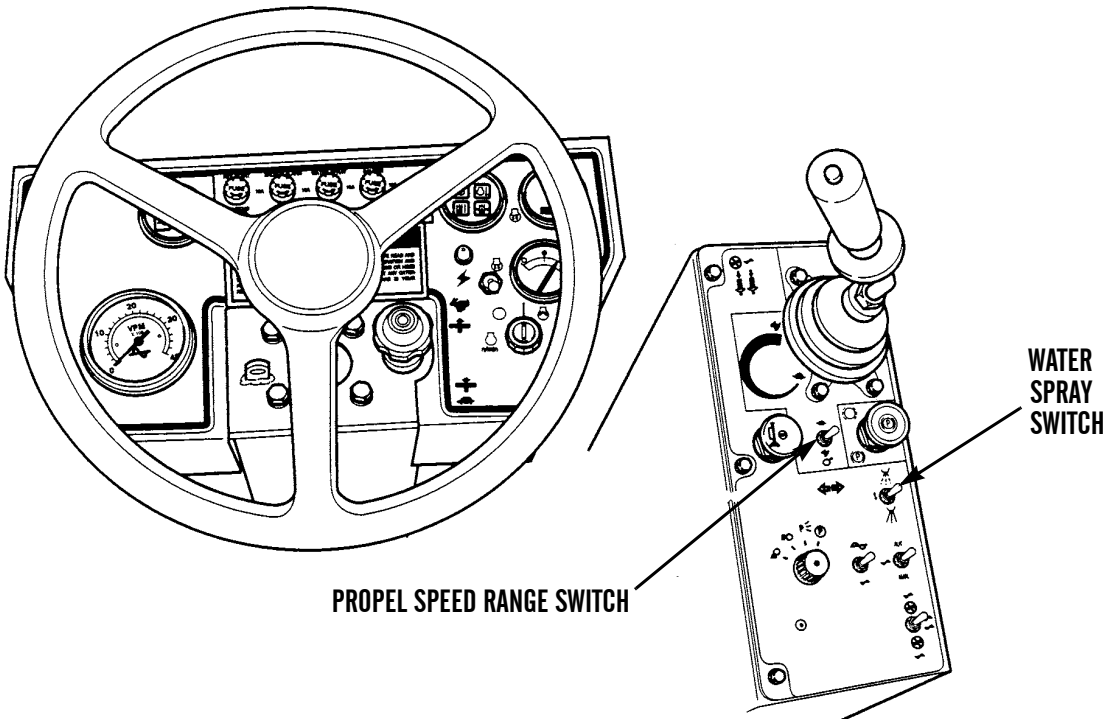
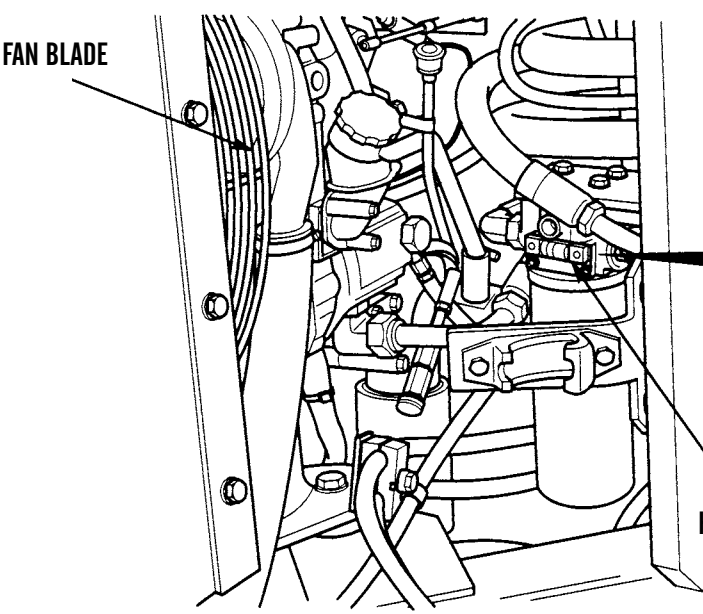
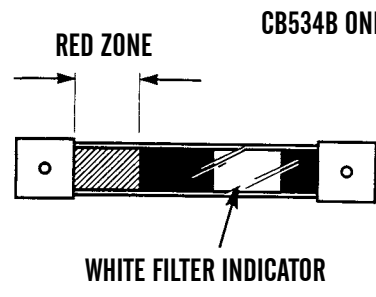
ITEM NO.	INTERVAL	MAN-HOURS	LOCATION ITEM TO CHECK/ SERVICE	PROCEDURE	NOT FULLY MISSION CAPABLE IF:
35	During		Steering	Check for any unusual steering noise, binding or difficulty in turning.	Steering binds or is unresponsive.
36	During	0.2 Hours	Hydraulic Oil Level (Warm Oil Check)	<p style="text-align: center;">CAUTION</p> <p>Do not overfill hydraulic oil tank. Damage to hydraulic system components may occur.</p> <p style="text-align: center;">NOTE</p> <ul style="list-style-type: none"> • The roller should be parked on level surface when checking the hydraulic oil level. • Hydraulic oil is checked warm and cold. Run engine at least five minutes before performing warm oil check. 	
37	After		Fuel Tank	Refuel roller (WP 0015 00).	Hydraulic oil level is below "LOW" level mark or above "HIGH" level mark on label.
38	After		Water Spray System	Drain and flush front and rear water tanks. Service all strainers (WP 0024 00).	
39	Weekly		Water Spray System	<p>a. Remove water spray screen element (WP 0024 00).</p> <p>b. Clean bowl and element with water.</p> <p>c. Install water spray screen element (WP 0024 00).</p> <p>d. Repeat steps a through c for second water tank located on the opposite end of the roller.</p>	
40	Weekly		Muffler/ Exhaust Pipes	Check muffler and exhaust system for decay, damage, and loose components.	

Table 1. Operator Preventive Maintenance Checks and Services (PMCS) for DSWR - Continued.

ITEM NO.	INTERVAL	MAN-HOURS	LOCATION ITEM TO CHECK/ SERVICE	PROCEDURE	NOT FULLY MISSION CAPABLE IF:
41	Weekly		Seat Belt	<p style="text-align: center;">NOTE</p> <p>A punch card is attached to the inboard side of the left seat belt retractor to record the age of the belt for replacement at the end of three years from the date of installation.</p> <p>Check seat belt for security, damage, proper operation, and expiration punch card date.</p>	<p>Seat belt is missing, damaged or three years have passed since seat belt was installed. Notify supervisor for replacement of seat belt.</p>
<div style="display: flex; justify-content: space-around; align-items: flex-start;"> <div style="text-align: center;">  <p>SEAT BELT</p> <p>LEFT SEAT BELT RETRACTOR</p> <p>EXPIRATION DATE PUNCH CARD</p> </div> <div style="text-align: center;">  <p>CATERPILLAR INSTALLATION DATE</p> <p>Pull belt from the belt-side only for proper adjustment See maintenance manual for inspection & replacement</p> <p>LOCATED ON LEFT SEAT BELT RETRACTOR</p> </div> </div> <p style="text-align: right;">401-033</p>					

Table 1. Operator Preventive Maintenance Checks and Services (PMCS) for DSWR - Continued.

ITEM NO.	INTERVAL	MAN-HOURS	LOCATION ITEM TO CHECK/ SERVICE	PROCEDURE	NOT FULLY MISSION CAPABLE IF:
41 (Con't)	Weekly		Seat Belt		
<div style="display: flex; justify-content: space-around; align-items: center;">  <div style="text-align: center;"> <p>RESILIENT MOUNT</p>  <p>401-034</p> </div> </div>					
NOTE					
42	Weekly		Resilient Blocks	Check resilient mounts for damage, cracking, splitting, and loose mounting hardware.	Resilient mounts are damaged, cracked split or have loose mounting hardware.
43	Weekly	0.3 Hours	Front and Rear Vibratory Bearing Reservoir	Check vibratory bearing reservoir oil level (WP 0020 00). If oil level is low, fill reservoir with oil (WP 0020 00).	Oil level is low.
44	Weekly	0.3 Hours	Front and Rear Propel Gearbox Oil Level	Check front and rear propel gearbox oil level. If oil level is low, fill propel gearbox with oil (WP 0021 00).	Oil level is low.

Table 1. Operator Preventive Maintenance Checks and Services (PMCS) for DSWR - Continued.

ITEM NO.	INTERVAL	MAN-HOURS	LOCATION ITEM TO CHECK/ SERVICE	PROCEDURE	NOT FULLY MISSION CAPABLE IF:
45	Weekly		Front and Rear Drum Scrapers	Clean, inspect, and check adjustment (WP 0023 00).	Drum scraper is damaged or worn beyond adjustment.
46	Weekly	0.2 Hours	Front and Rear Ring Bearings	Apply GAA grease (Item 9, WP 0029 00) to two grease fittings at front and rear ring bearings (WP 0011 00).	

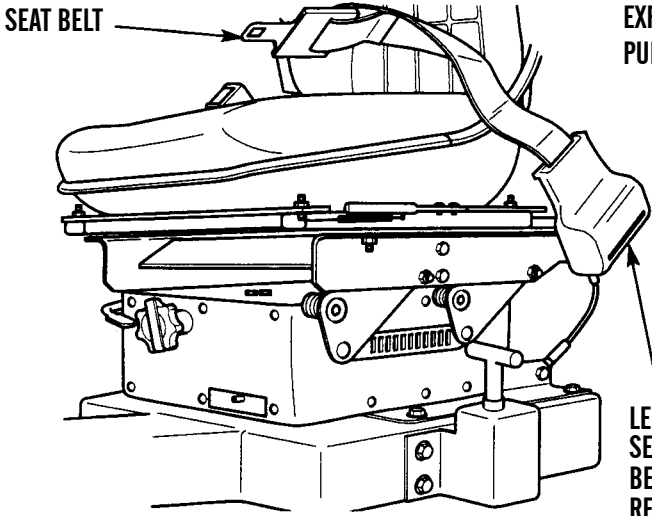
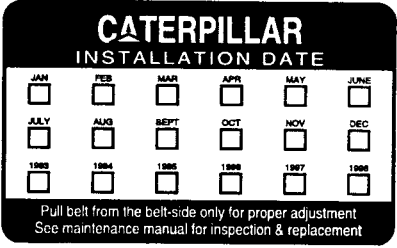
END OF WORK PACKAGE

INSPECTION OF COMPONENTS

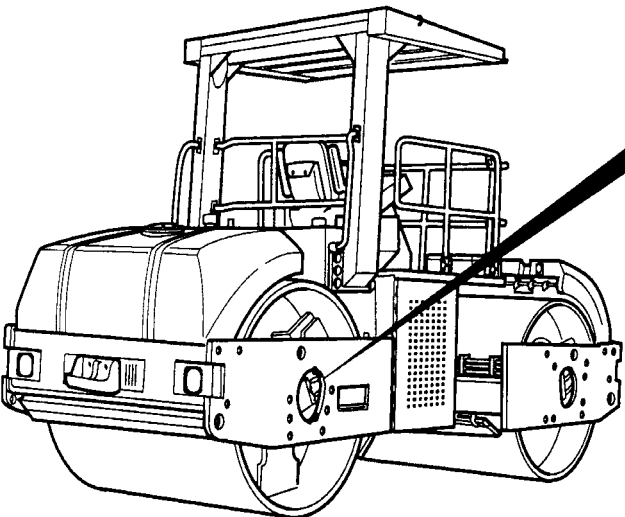
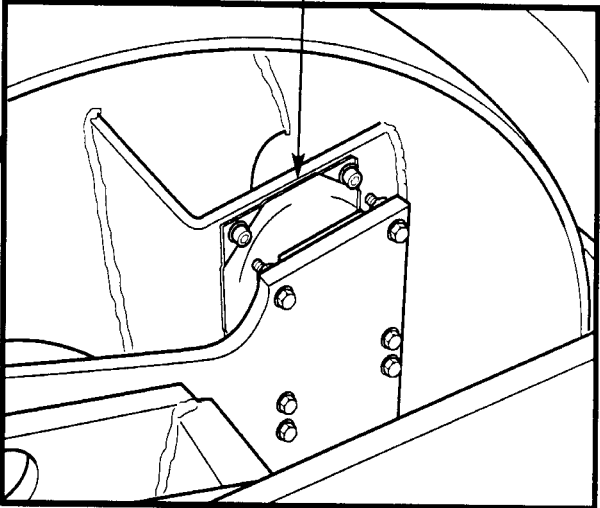
1. Clean all parts before inspection. Check for defects such as physical distortion, wear, cracks and pitting.
2. Check all hose surfaces for broken or frayed fabric, breaks caused by sharp kinks or chafing against other parts of the unit. Inspect metal tubing lines for kinks. Inspect fitting threads for damage. Replace any defective parts. Check for leaks after assembly and during initial operation period.
3. Visually inspect all castings and weldments for cracks.
4. Inspect all wiring for chafed or burned insulation. Inspect all terminal connectors for loose connections and broken parts.

CLEANING PROCEDURES

1. For exterior cleaning of frame and structural components, use detergent (Item 5, WP 0029 00) in a solution as recommended on the container. Leave application on surface for approximately 10 minutes before rinsing. Rinse with hot or cold water under pressure. If available, use hot water under 80-120 lb (551-827 kPa) pressure. An ordinary garden hose may be used if no other equipment is available. If pressurized water supply is not available, wash painted surfaces with a solution of 1/4 cup soap (Item 17, WP 0029 00) to one gallon of water.

**WARNING**

Cleaning compound, solvent MIL-PRF-680 Type III is an environmentally compliant and low toxic material. However, it may be irritating to the eyes and skin. Use protective gloves and goggles. Use in well-ventilated areas. Keep away from open flames and other sources of ignition.

NOTE

Do not use dielectric grease on electrical connectors.

2. Electrical parts such as coils, connectors, switches and insulating wiring shall not be soaked or sprayed with cleaning solutions. Clean these parts with a clean, dry cloth moistened with cleaning compound, solvent (Item 3, WP 0029 00).

REMOVAL OF COMPONENTS

1. Ensure that adequate clearance is available for removal of component. Disassemble roller to extent necessary to provide adequate working clearance.
2. Remove parts only when service is required. Do not disassemble a component further than necessary to accomplish service.

ASSEMBLY AND INSTALLATION

Ensure that all parts are clean and dry before installation. If you lose or damage a component during servicing, notify supervisor for replacement.

END OF WORK PACKAGE

ENGINE OIL LEVEL CHECK AND SERVICE

0014 00

THIS WORK PACKAGE COVERS

Check Engine Oil Level, Service Engine Oil Level

INITIAL SETUP**Materials/Parts**

- Oil, lubricating (Item 10, 13 or 14, WP 0029 00)
- Rag, wiping (Item 16, WP 0029 00)
- Container, 1 qt capacity

References

- WP 0011 00, Operator Preventive Maintenance Check and Services (PMCS) Introduction

Equipment Condition

- Engine off (WP 0005 00)
- Roller parked on level ground (WP 0005 00)
- Drums chocked (WP 0005 00)
- Right-side door assembly opened (WP 0005 00)

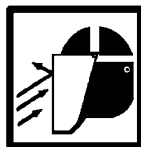
**WARNING**

- Oil is very slippery. Immediately wipe up any spills. Failure to follow this warning may cause injury.
- Hot oil or metal parts can cause burns. Wear insulated gloves, long sleeves and eye protection when working with heated parts.

NOTE

Use container to catch any oil that may drain from system. Dispose of oil IAW local policy and ordinances.

CHECK ENGINE OIL LEVEL

1. Remove gauge rod (dipstick) (1) from gauge rod (dipstick) tube (2) and wipe clean.
2. Insert gauge rod (dipstick) (1) in gauge rod (dipstick) tube (2).
3. Remove gauge rod (dipstick) (1) from gauge rod (dipstick) tube (2).
4. Check engine oil level. Oil level should be between marks on gauge rod (dipstick) (1).
5. Install gauge rod (dipstick) (1) in gauge rod (dipstick) tube (2).
6. If necessary, add engine oil. Refer to *Service Engine Oil Level* in this work package.

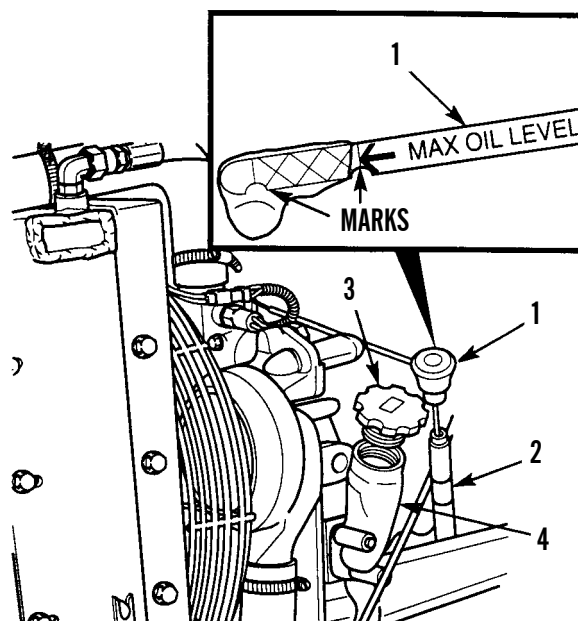

401-097

ENGINE OIL LEVEL CHECK AND SERVICE

SERVICE ENGINE OIL LEVEL

1. Remove cap (3) from oil filler assembly (4).

CAUTION

Do not overfill crankcase or damage will occur to engine.

NOTE

For quantity and type, refer to *KEY* in WP 0011 00.

2. Add oil to crankcase.
3. Install oil cap (3) on oil filler assembly (4).
4. Check engine oil level. Oil level should be between marks on gauge rod (dipstick) (1).
5. Close right-side door assembly (WP 0005 00).
6. Remove chocks (WP 0005 00).

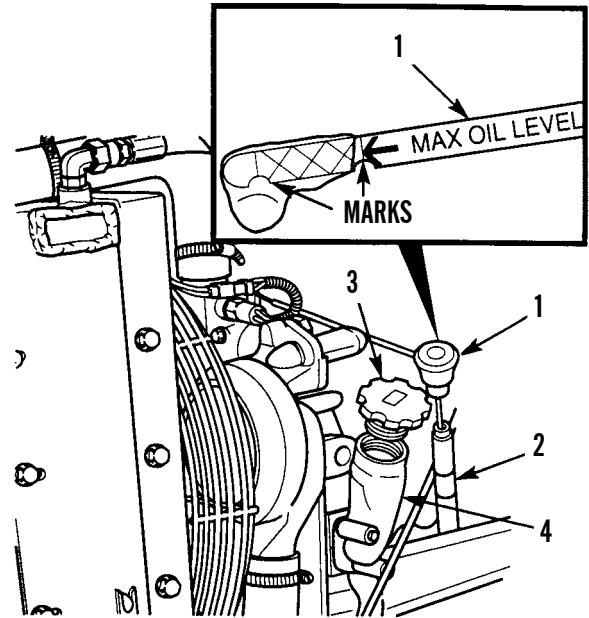

401-097

END OF WORK PACKAGE

FUEL LEVEL CHECK AND SERVICE

0015 00

THIS WORK PACKAGE COVERS

Check Fuel Level, Drain Fuel Filter, Fill Fuel Tank

INITIAL SETUP**Materials/Parts**

Fuel (Item 6, 7 or 8, WP 0029 00)
Container, 1 qt. capacity

Equipment Condition

Engine off (WP 0005 00)
Roller parked on level ground (WP 0005 00)
Drums chocked (WP 0005 00)

**WARNING**

- DO NOT perform fuel system checks, inspections or maintenance while smoking or near fire, flames or sparks. Fuel may ignite, causing injury, death or damage to roller.
- DO NOT perform fuel system checks, inspections or maintenance while smoking or near fire, flames or sparks. Fuel may ignite, causing injury, death or damage to roller.
- Wear fuel-resistant gloves when handling fuels and promptly wash exposed skin and change fuel-soaked clothing.
- Place portable fire extinguisher within reach prior to refueling.
- DO NOT overfill tank. If fuel starts foaming from fuel tank, stop immediately to avoid fuel spillage.
- Fuel is very slippery. If fuel is spilled, clean fuel up immediately. Before starting roller, check that no fuel is spilled on or around machine.

NOTE

Fuel level check and service is performed the same way for the CB534B and CB534C Rollers. The CB534B Roller is shown.

CHECK FUEL LEVEL

1. Check fuel level gauge (1).
2. Fill tank as necessary. Refer to *Fill Fuel Tank* in this work package.

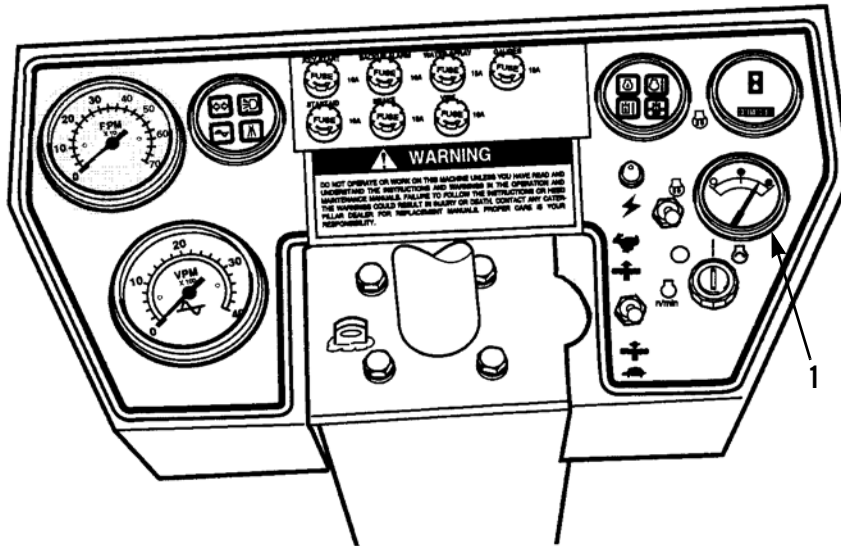

401-2197

DRAIN FUEL FILTER**NOTE**

Use a container to catch fuel drained from system. Dispose of fuel IAW policy and ordinances. Ensure all spills are cleaned up.

1. On CB534B Roller, close fuel supply valves (1). On CB534C Roller, close fuel supply valves (2).
2. Place container under drain valve (3).
3. Open drain valve (3) on bottom of filter element (4) and drain fuel into container.
4. For the CB534B Roller, open fuel supply valves (1). For CB534C Roller, open fuel supply valves (2).

DRAIN FUEL FILTER - CONTINUED

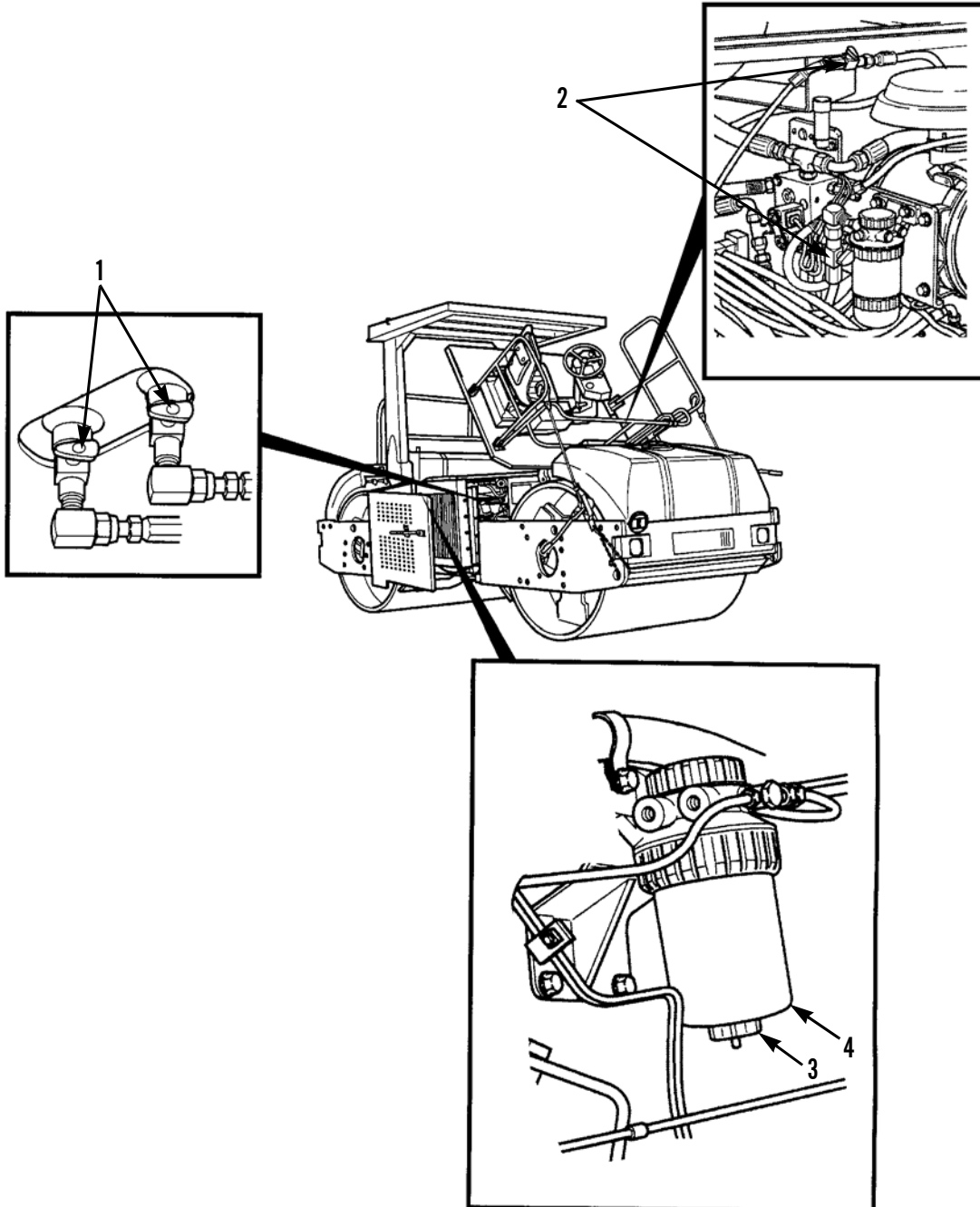

401-2230

FILL FUEL TANK

1. Remove padlock (2) from fuel cap assembly (3).
2. Remove fuel cap assembly (3) from fuel tank (4) by turning cap counterclockwise until free from tank.
3. Inspect strainer (5) for debris.
4. If debris is found, remove strainer (5) from fuel tank (4) and remove debris.
5. If removed, install strainer (5) in fuel tank (4).

NOTE

Fuel tank capacity is 55 gal. (208 l).

6. Fill tank (4) with diesel or JP-8 fuel only.
7. Immediately after filling, install fuel cap assembly (3) on fuel tank (4) by turning fuel cap assembly clockwise.
8. Install padlock (2) on fuel cap assembly (3), one eye left of lock stop.

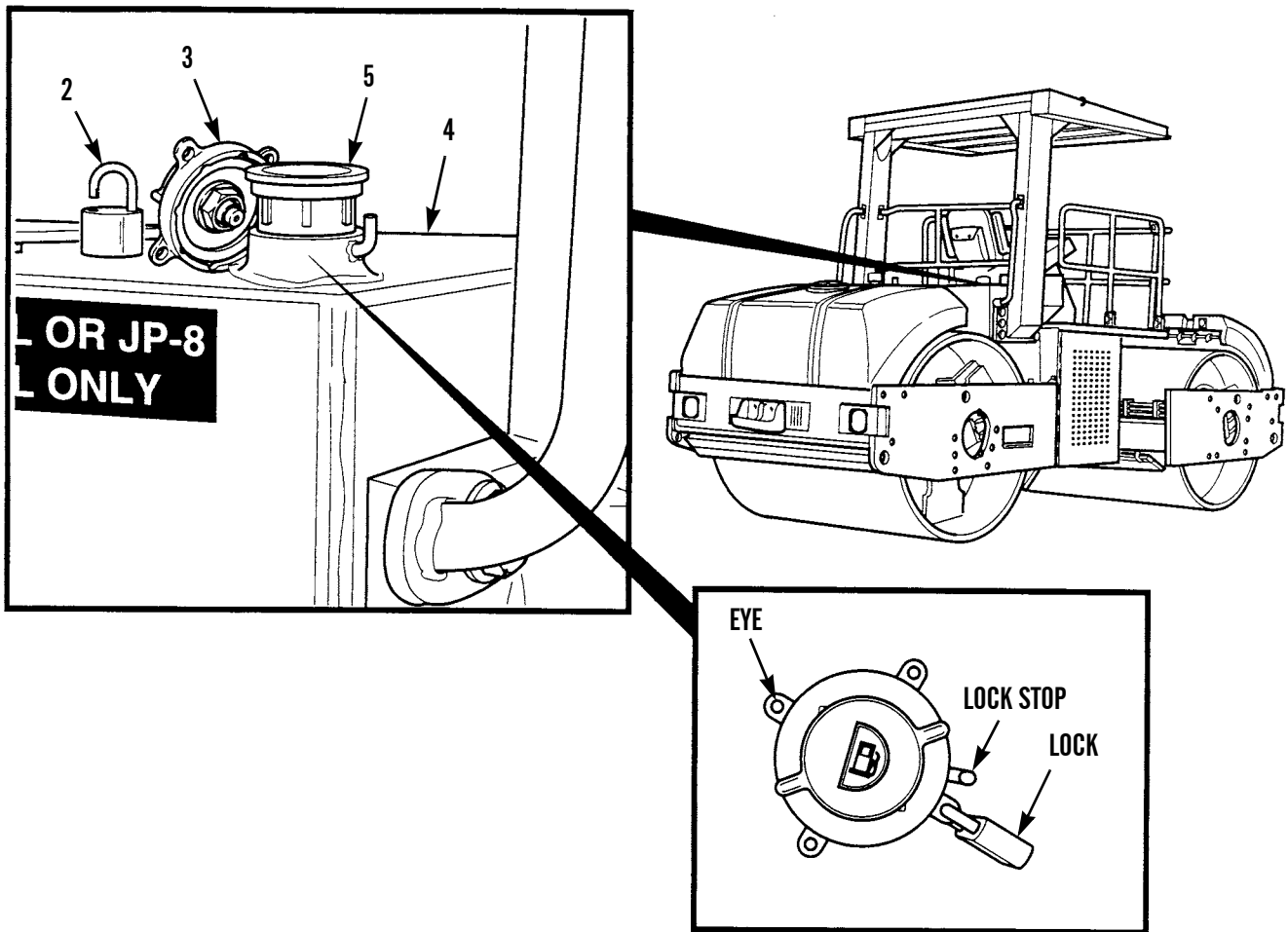

401-099

9. Remove chocks (WP 0005 00).

END OF WORK PACKAGE

FUEL/WATER SEPARATOR SERVICE

0016 00**THIS WORK PACKAGE COVERS**

Drain

INITIAL SETUP**Materials/Parts**

Container, 1 qt capacity

Equipment Condition

Engine off (WP 0005 00)

Roller parked on level ground (WP 0005 00)

Drums chocked (WP 0005 00)

Left-side door assembly opened (CB534B) (WP 0005 00)

**WARNING**

- DO NOT perform fuel system checks, inspections or maintenance while smoking or near fire, flames or sparks. Fuel may ignite, causing injury, death or damage to roller.
- DO NOT perform fuel system checks, inspections or maintenance while smoking or near fire, flames or sparks. Fuel may ignite, causing injury, death or damage to roller.
- Place portable fire extinguisher within reach prior to draining fuel/water separator.
- Wear fuel-resistant gloves when handling fuels and promptly wash exposed skin and change fuel-soaked clothing.
- Fuel is very slippery. If fuel is spilled, clean fuel up immediately. Before starting roller, check that no fuel is spilled under machine.

DRAIN**NOTE**

Use container to catch any fuel or water that may drain from system. Dispose of fuel IAW local policy and ordinances.

1. Open valve (1) by turning counterclockwise and allow fluid to drain until only fuel drains from fuel/water separator (2).
2. Close valve (1) by turning clockwise.

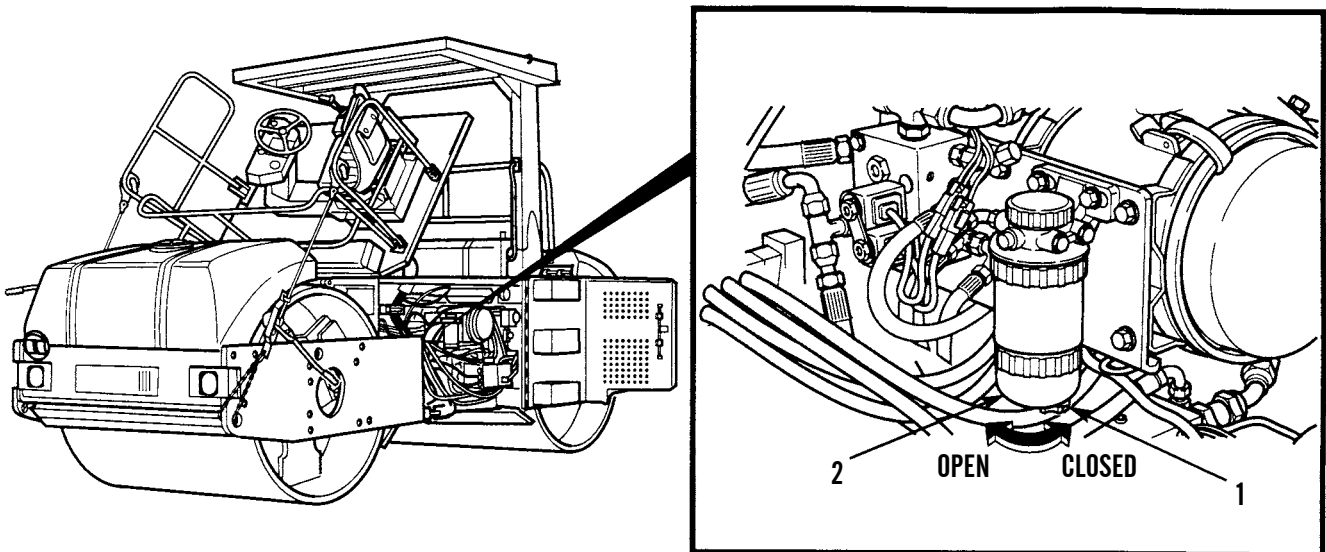

401-2190

3. Close left-side door assembly (WP 0005 00).
4. Remove chocks (WP 0005 00).

END OF WORK PACKAGE

ENGINE COOLANT CHECK AND SERVICE

0017 00**THIS WORK PACKAGE COVERS**Check and Fill

INITIAL SETUP**Materials/Parts**

Antifreeze (Item 1, WP 0029 00)
Rag, wiping (Item 16, WP 0029 00)

Equipment Condition

Engine off (WP 0005 00)
Roller parked on level ground (WP 0005 00)
Drums chocked (WP 0005 00)
Right-side door assembly opened (WP 0005 00)

**WARNING**

- DO NOT service cooling system unless engine has cooled. This is a pressurized cooling system and escaping steam or hot coolant may cause burns.
- DO NOT remove radiator cap when engine is hot. Allow engine to cool down. Loosen cap to first stop and let any pressure out of cooling system, then remove cap. Failure to follow this warning may cause burns.
- Wear effective eye, glove, and skin protection when handling coolants. Failure to do so may cause injury.

CHECK AND FILL

1. Pull lever (1) and open access door (2). Release lever.
2. Remove radiator cap (3) by turning left slowly to relieve coolant system pressure.
3. Check coolant level. Coolant level should be approximately 3 in. (7.6 cm) below fill port.

CAUTION

Do not fill coolant system with water only. Use ethylene glycol mixture (antifreeze) with water. Failure to do so will result in damage to engine.

4. If necessary, fill radiator (4) with a 50/50 mixture of water/antifreeze to approximately 3 in. (7.6 cm) below fill port.
5. Install radiator cap (3) on radiator (4) by turning cap to full right.
6. Pull lever (1) and close access door (2).

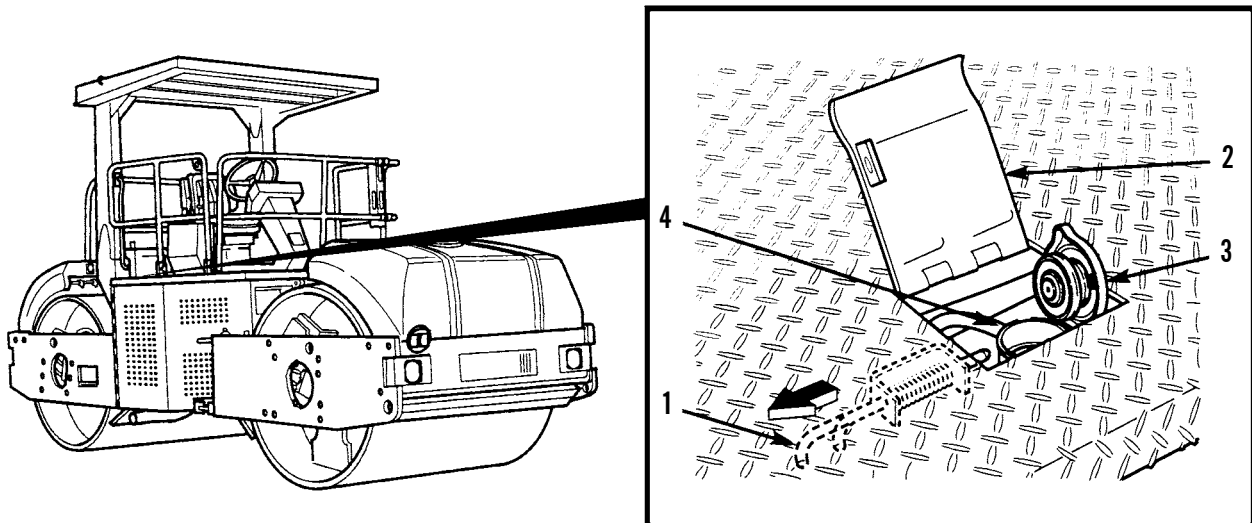

7. Release lever to lock access door in position.
8. Close right-side door assembly (WP 0005 00).
9. Remove chocks (WP 0005 00).

END OF WORK PACKAGE

HYDRAULIC OIL LEVEL CHECK AND SERVICE

0018 00

THIS WORK PACKAGE COVERS

Check Hydraulic Oil Level, Fill Hydraulic Oil Tank

INITIAL SETUP**Materials/Parts**

- Oil, lubricating (Item 10 or 13, WP 0029 00)
- Rag, wiping (Item 16, WP 0029 00)

References

- WP 0011 00, Operator Preventive Maintenance Checks and Services (PMCS) Introduction

Equipment Condition

- Engine off (WP 0005 00)
- Roller parked on level ground (WP 0005 00)
- Drums chocked (WP 0005 00)

CHECK HYDRAULIC OIL LEVEL

1. Observe hydraulic oil level indicator (1).

NOTE

Oil level shall be maintained between “FULL” and “ADD” lines on decal located beside hydraulic oil level indicator.

2. Add hydraulic oil as necessary. Refer to *Fill Hydraulic Oil Tank* in this work package.

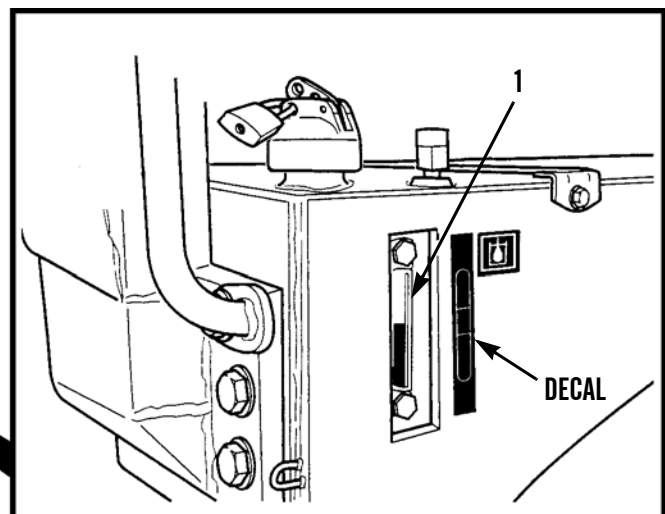
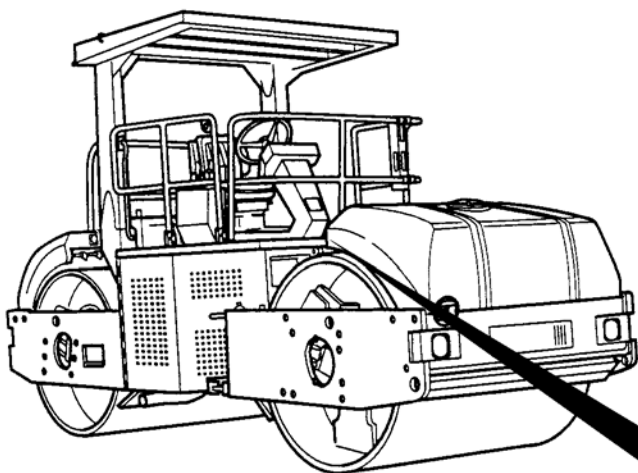

401-100

FILL HYDRAULIC OIL TANK**WARNING**

- DO NOT remove hydraulic oil cap assembly when hydraulic system is hot. Allow hydraulic oil to cool. Loosen slowly and let any pressure out of hydraulic system, then remove cap. Failure to follow this warning may cause burns.
 - Oil is very slippery. Immediately wipe up any spills. Failure to follow this warning may cause injury.
1. Remove padlock (2) from hydraulic oil cap assembly (3).
 2. Lift lever and remove hydraulic oil cap assembly (3) from hydraulic oil tank (4) by turning cap counterclockwise.
 3. Remove strainer (5) from hydraulic oil tank (4) and inspect for debris. Remove debris as necessary.
 4. Clean and install strainer (5) in hydraulic oil tank (4).

NOTE

Refer to *KEY* in WP 0011 00 for quantity and type of oil.

5. Add oil through strainer (5) and fill tube (6) until oil level indicator (1) is between FULL and ADD marks on decal located beside hydraulic oil level indicator.
6. Lift lever and install hydraulic oil cap assembly (3) on hydraulic oil tank (4) by turning cap clockwise.
7. Install padlock (2) on hydraulic oil cap assembly (3) while lever is fully down.

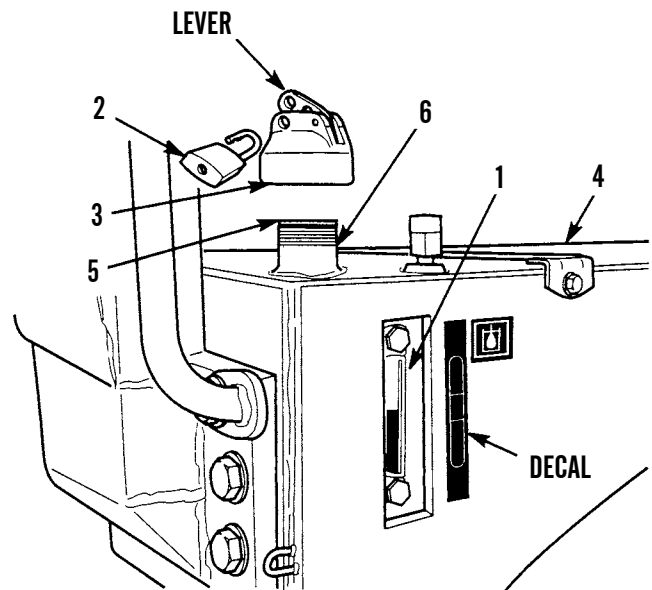

401-101

END OF WORK PACKAGE

DRAINING AND FILLING FUEL AND HYDRAULIC OIL TANKS**0019 00****THIS WORK PACKAGE COVERS**

Drain Fuel Tank, Drain Hydraulic Oil Tank, Cleaning and Inspection, Fill Fuel Tank, Fill Hydraulic Oil Tank

INITIAL SETUP**Tools and Special Tools**

Wrench, box and open end, combination (Item 5, WP 0027 00)

Materials/Parts

Oil, lubricating (Item 10 or 13, WP 0029 00)
 Rag, wiping (Item 16, WP 0029 00)
 Fuel (Item 6, 7 or 8, WP 0029 00)
 Packing, preformed (2)
 Container, 55 gal. minimum capacity (fuel tank)
 Container, 15.5 gal. minimum capacity (CB534B Roller) or 24 gal. minimum capacity (CB534C Roller)

References

WP 0011 00, Operator Preventive Maintenance Checks and Services (PMCS) Introduction

Equipment Condition

Engine off (WP 0005 00)
 Roller parked on level ground (WP 0005 00)
 Drums chocked (WP 0005 00)
 Left-side door assembly opened (hydraulic oil tank) (WP 0005 00)
 Right-side door assembly opened (fuel tank) (WP 0005 00)

DRAIN FUEL TANK**WARNING**

- DO NOT perform fuel system checks, inspections or maintenance while smoking or near fire, flames or sparks. Fuel may ignite, causing injury, death or damage to roller.
- Wear fuel-resistant gloves when handling fuels and promptly wash exposed skin and change fuel-soaked clothing.
- Place portable fire extinguisher within reach prior to draining fuel tank.
- Fuel is very slippery. To avoid injury, wipe up spilled fuel with rags. Before starting roller, check that no fuel is spilled on or around machine.

NOTE

- Dispose of fuel IAW local policy and ordinances.
- Fuel tank capacity is 55 gal. (208 l).

DRAINING FUEL TANK - CONTINUED

1. Remove 24 mm wrench from toolbox.
2. Using 24 mm wrench, remove cap (1) and preformed packing (2) from elbow (3). Discard preformed packing.
3. Allow fuel to drain completely into containers.

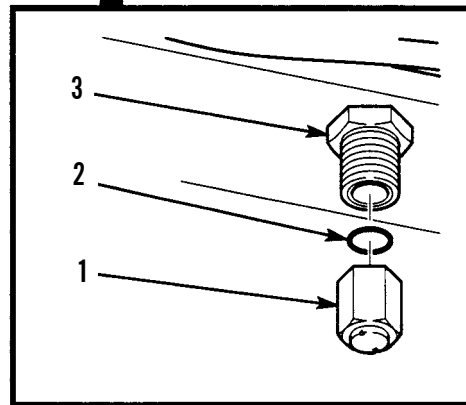
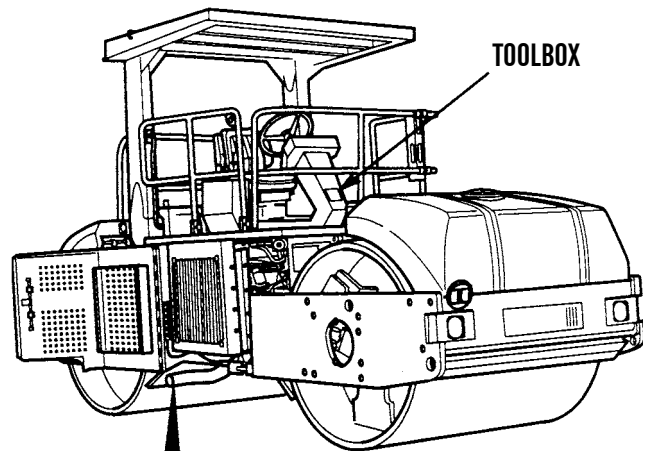

401-102

DRAIN HYDRAULIC OIL TANK



WARNING



- At operating temperature hydraulic oil is hot. Allow hydraulic oil to cool before disconnecting any hydraulics. Failure to do may cause injury.
- Oil is very slippery. Immediately wipe up any spills. Failure to follow this warning may cause injury.

NOTE

- Use container to catch draining oil. Dispose of oil IAW local policy and ordinances.
- Hydraulic oil tank capacity of the CB534B Roller is 15.5 gal. (59 l). Hydraulic oil tank capacity of the CB534C Roller is 24 gal (91 l).

1. Remove 24 mm wrench from toolbox.
2. Using 24 mm wrench, remove cap (4) and preformed packing (5) from union (6). Discard preformed packing.
3. Allow hydraulic oil to drain completely into container.

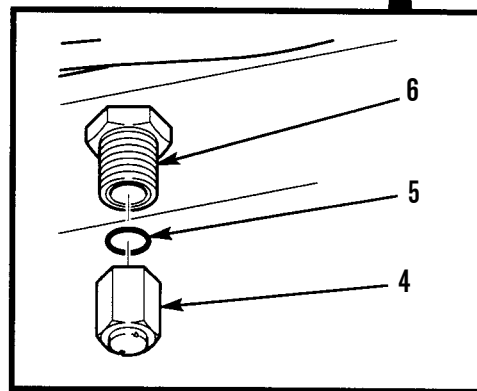
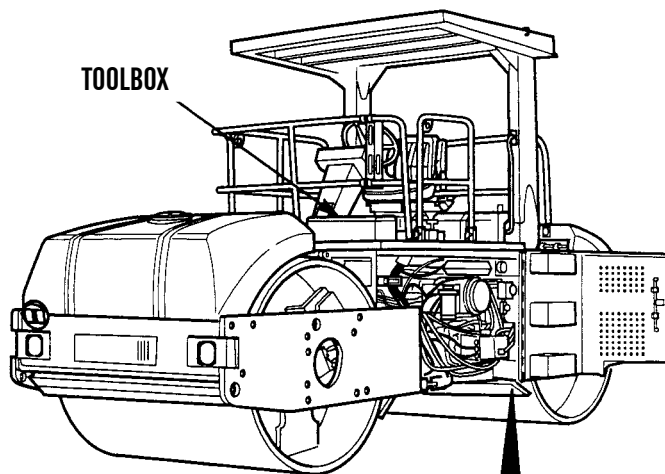

401-103

CLEANING AND INSPECTION**CAUTION**

Dirt, grit, and metallic particles can cause damage to hydraulic and engine components. Cap and hose assembly should be clean before cap is installed.

1. Inspect for metallic particles in cap.
2. Inspect union and elbow threads and cap threads for damage.
3. Clean caps, union, elbow, and around union and elbow.
4. Clean cap threads and hydraulic tank hose assembly threads with clean hydraulic oil and rags.
5. Notify supervisor for replacement of lost or damaged parts.

FILL HYDRAULIC OIL TANK**WARNING**

Oil is very slippery. Immediately wipe up any spills. Failure to follow this warning may cause injury.

NOTE

- Hydraulic oil tank capacity of the CB534B Roller is 15.5 gal. (59 l). Hydraulic oil tank capacity of the CB534C Roller is 24 gal (91 l).
- Refer to *KEY* in WP 0011 00 for type of oil.

1. Using 24 mm wrench, install new preformed packing (5) and cap (4) on union (6).
2. Remove cap (7) from hydraulic tank (8).
3. Fill hydraulic tank (8) with hydraulic oil.
4. Install cap (7) on hydraulic tank (8).
5. Stow 24 mm wrench in toolbox.
6. Close left-side door assembly (WP 0005 00).

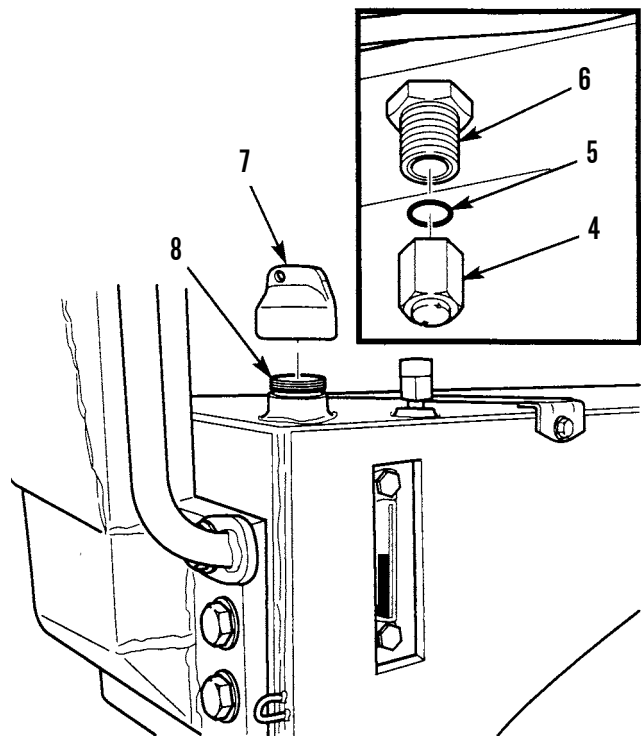

401-104

FILL FUEL TANK**WARNING**

- DO NOT perform fuel system checks, inspections or maintenance while smoking or near fire, flames or sparks. Fuel may ignite, causing injury, death or damage to roller.
- Wear fuel-resistant gloves when handling fuels and promptly wash exposed skin and change fuel-soaked clothing.
- Place portable fire extinguisher within reach prior to refueling.
- DO NOT overfill tank. If fuel starts foaming from fuel tank, stop immediately to avoid fuel spillage.
- Fuel is very slippery. If fuel is spilled, clean fuel up immediately to avoid injury. Before starting roller, check that no fuel is spilled on or around machine.

NOTE

Fuel tank capacity is 55 gal. (208 l).

1. Using 24 mm wrench, install new preformed packing (2) and cap (1) on elbow (3).
2. Remove cap (9) from fuel tank (10).
3. Fill fuel tank (10) with 55 gal. (208 l) of fuel.
4. Install cap (9) on fuel tank (10).
5. Stow 24 mm wrench in toolbox.
6. Close right-door assembly (WP 0005 00).

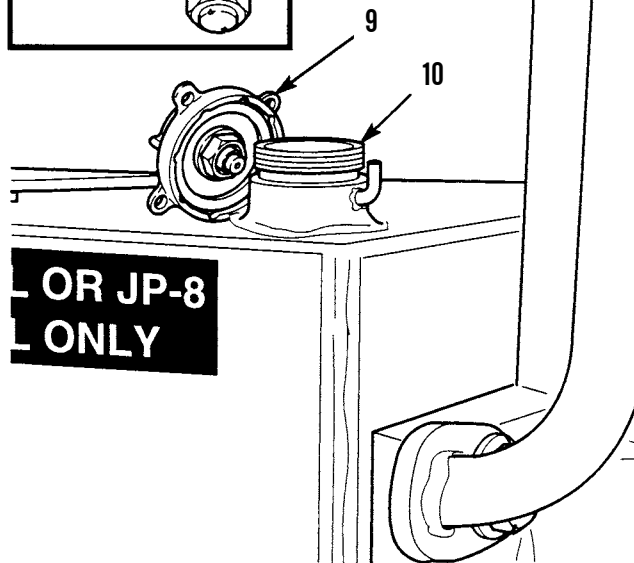
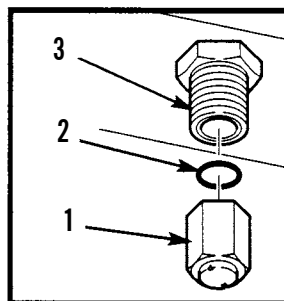

401-105

END OF WORK PACKAGE

VIBRATORY BEARING RESERVOIR CHECK AND SERVICE**0020 00****THIS WORK PACKAGE COVERS**

Check, Fill

INITIAL SETUP**Tools and Special Tools**

Handle, socket wrench (Item 7, WP 0027 00)

Materials/Parts

Oil, synthetic (Item 15, WP 0029 00)

Rag, wiping (Item 16, WP 0029 00)

Container, 1 qt. capacity

References

WP 0011 00, Operator Preventive Maintenance Checks and Services (PMCS) Introduction

Equipment Condition

Roller parked on level ground (WP 0005 00)

Vibratory system off (WP 0005 00)

NOTE

- The roller vibratory system consists of two similar vibratory systems located at each end of roller. The vibratory bearing reservoir oil level gauges are located on left side of front drum and right side of rear drum.
- This work package covers checking and servicing of one vibrating bearing reservoir. Both vibratory bearing reservoirs are checked and serviced in the same way.

CHECK

1. Start engine (WP 0005 00).
2. Move roller until bar (1) is at bottom of drum (2).
3. Turn off engine (WP 0005 00).
4. Set parking brake (WP 0005 00).
5. Check oil level gauge (3). Oil level should fill half of viewing area of oil level gauge.
6. Fill vibratory bearing reservoir when required. Refer to *Fill* in this work package.

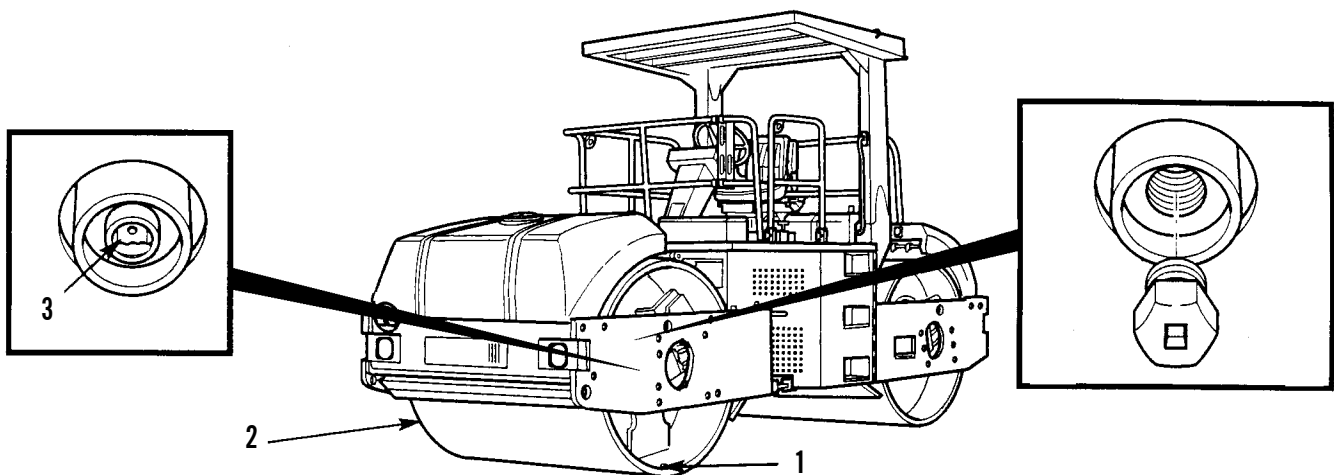

401-106

FILL

1. Remove 1/2 in. drive ratchet from toolbox.

**WARNING**

Oil is very slippery. Immediately wipe up any spills. Failure to follow this warning may cause injury.

NOTE

Use a container to catch any oil that may drain from system. Dispose of oil IAW local policy and ordinances.

2. Remove plug (4) from vibratory reservoir (5) using 1/2 in. drive ratchet.
3. Add oil (WP 0011 00).
4. Clean plug (4) and area around plug opening.
5. Inspect threads on plug (4) for crossed or peeled condition.

NOTE

Notify Field Maintenance for replacement of damaged plug.

6. Install plug (4) in vibratory reservoir (5) using 1/2 in. drive ratchet. Tighten plug securely.
7. Stow 1/2 in. drive ratchet in toolbox.

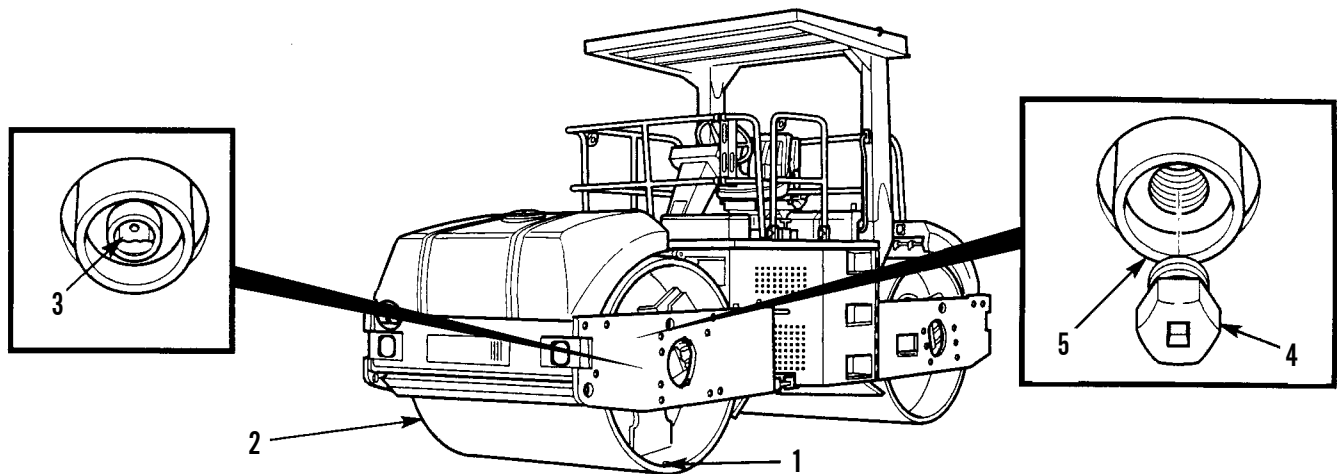

401-2179

END OF WORK PACKAGE

FRONT AND REAR PROPEL GEARBOX OIL CHECK AND SERVICE (CB534B)

0021 00**THIS WORK PACKAGE COVERS**

Oil Level Check, Cleaning and Inspection, Fill

INITIAL SETUP**Tools and Special Tools**

Handle, socket wrench (Item 7, WP 0027 00)
Extension (Item 8, WP 0027 00)
Adapter (Item 9, WP 0027 00)
Screwdriver attachment, socket wrench (Item 10,
WP 0027 00)
Container, 1 qt. capacity

Materials/Parts

Oil, lubricating gear (Item 11 and 12, WP 0029 00)
Rag, wiping (Item 16, WP 0029 00)

Equipment Condition

Engine on (WP 0005 00)
Roller parked on level ground (WP 0005 00)

NOTE

- The roller propel system consists of two similar propel systems located at each end of the roller. Propel gearbox oil level plugs are located on right-side of front drum and left-side of rear drum.
- This work package covers checking and servicing of one propel gearbox. Both propel gearboxes are checked and serviced in the same way.

OIL LEVEL CHECK

1. Move roller until level check plug (1) is located at 12 o'clock position and fill plug (2) is located at 3 o'clock position.
2. Turn engine off (WP 0005 00).
3. Remove 1/2 in. drive ratchet, 6 in. extension, adapter and 5/16 in. hex bit from toolbox.
4. Attach 1/2 in. drive ratchet, adapter and 5/16 in. hex bit to 6 in. extension.
5. Remove oil level check plug (1) at 12 o'clock position, from gearbox (3) through access hole.
6. Start engine (WP 0005 00).
7. Move roller to position opening for oil level check plug (1) at 9 o'clock position.
8. Turn off engine (WP 0005 00).
9. Maintain oil level to bottom of level check plug (1) opening.
10. If oil level is low, skip steps 10 through 15 and go to *Cleaning and Inspection* in this work package.

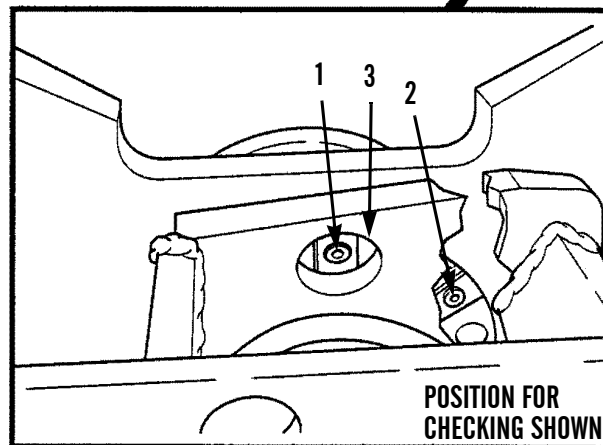
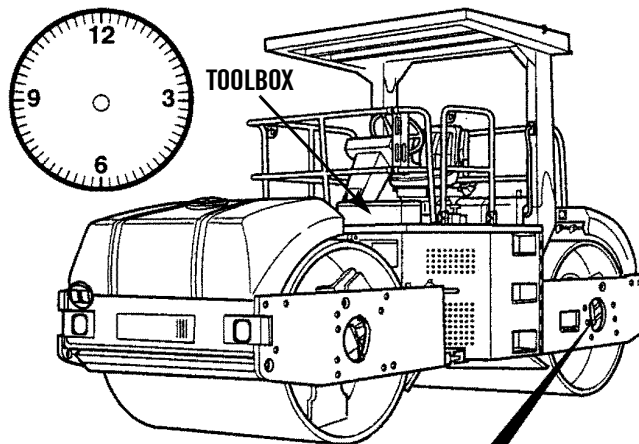

401-108

11. Start engine (WP 0005 00).
12. Move roller to position opening for oil level check plug (1) at 12 o'clock position.
13. Turn off engine (WP 0005 00).
14. Clean and inspect oil level check plug (1).
15. Install oil level check plug (1) through access hole in gearbox (3).
16. Stow 1/2 in. drive ratchet, 6 in. extension, and 5/16 in. hex bit in toolbox.

CLEANING AND INSPECTION

NOTE

Notify Field Maintenance to replace plug if damaged.

1. Clean plug (1) and area around plug openings.
Inspect threads on plug (1) for crossed or peeled condition.

FILL

1. Level check plug (1) is located at 9 o'clock position and fill plug (2) is located at 12 o'clock position.
2. Turn off engine (WP 0005 00).
3. Remove fill plug (2), at 12 o'clock position from gearbox (3) through access hole.

**WARNING**

Oil is very slippery. Immediately wipe up any spills. Failure to follow this warning may cause injury.

CAUTION

Do not overfill propel gearbox. Damage to equipment may result from too much oil in propel gearbox.

NOTE

Use a container to catch any oil that may drain from system. Dispose of oil IAW local policy and ordinances.

4. Add oil until oil level is at the bottom of the oil level check plug (1) opening. Refer to *Oil Level Check* in this work package.
5. Install fill plug (2) through access hole in gearbox (3).
6. Move roller until the oil level check plug (1) opening is at 12 o'clock position and fill plug (2) is at 3 o'clock position.
7. Install oil level check plug (1) through access hole in gearbox (3).
8. Stow 1/2 in. drive ratchet, 6 in. extension, and 5/16 in. hex bit in toolbox.

END OF WORK PACKAGE

ADJUST HANDRAILS FOR OPERATION OR STOWAGE

0022 00

THIS WORK PACKAGE COVERS

Adjust for Operation, Adjust for Stowage

INITIAL SETUP

Tools and Special Tools

Wrench, box and open end, combination (Item 5, WP 0027 00)

Personnel Required

Two

Equipment Condition

Engine off (WP 0005 00)

Roller parked on level ground (WP 0005 00)

Drums chocked (WP 0005 00)

ADJUST FOR OPERATION

1. Remove 24 mm wrench from toolbox.



WARNING

Use caution when handling heavy parts. Provide adequate support and use assistance during procedure. Failure to follow this warning may cause injury.

CAUTION

Failure to hold handrail assembly in place during removal will allow handrail assembly to fall and become damaged.

2. While assistant holds left handrail assembly (1), remove two bolts (2) and washers (3) from plate assemblies (4) using 24 mm wrench.
3. Lower handrail assembly (1) until holes in handrail align with middle holes in plate assemblies (4).
4. Install two washers (3) and bolts (2) in middle holes in handrail assembly (1) and plate assemblies (4). Tighten bolts securely using 24 mm wrench.
5. Repeat steps 1 through 4 for right handrail.
6. Stow 24 mm wrench in toolbox.

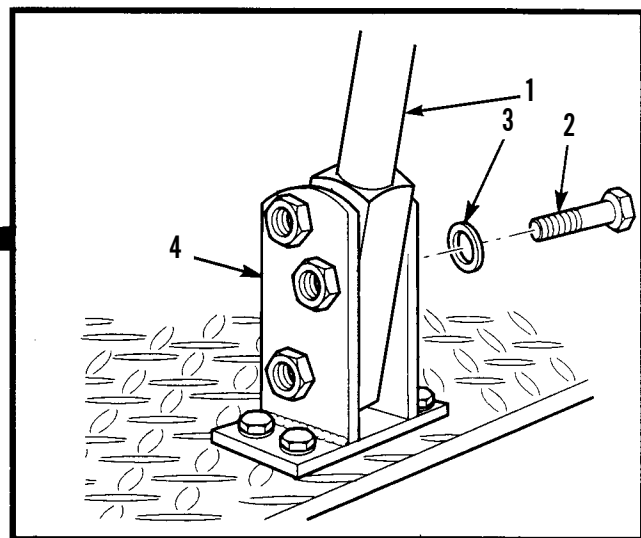
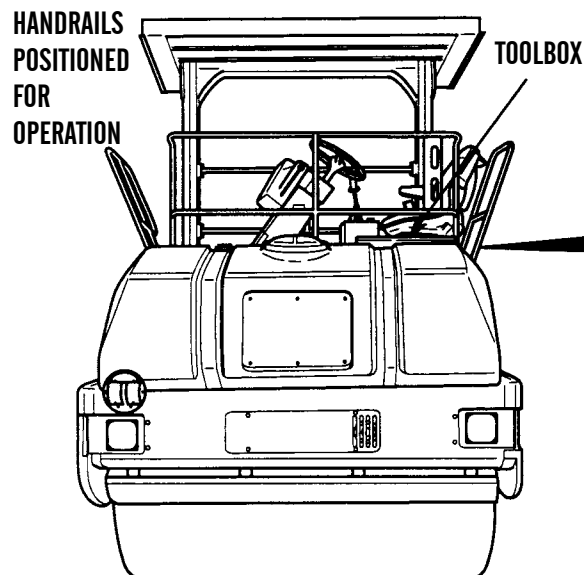

401-2195

ADJUST FOR STOWAGE

1. Remove 24 mm wrench from toolbox.



WARNING

Use caution when handling heavy parts. Provide adequate support and use assistance during procedure. Failure to follow this warning may cause injury.

CAUTION

Failure to hold handrail assembly in place during removal will allow handrail assembly to fall and become damaged.

2. While assistant holds left handrail assembly (1), remove two bolts (2) and washers (3) from plate assemblies (4) using 24 mm wrench.
3. Raise handrail assembly (1) until holes in handrail align with top holes in plate assemblies (4).
4. Install two washers (3) and bolts (2) in middle holes in handrail assembly (1) and plate assemblies (4). Tighten bolts securely using 24 mm wrench.

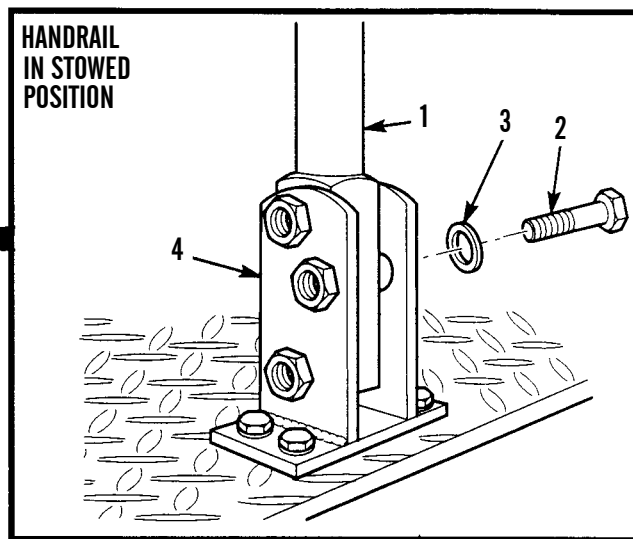
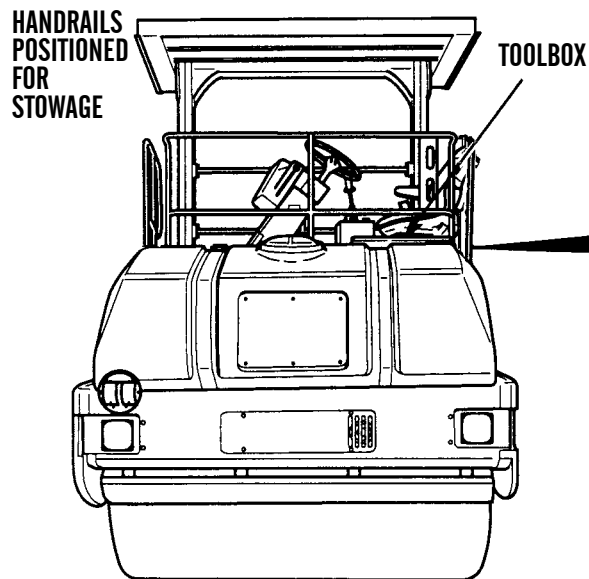

401-2196

5. Repeat steps 1 through 4 for right handrail.
6. Stow 24 mm wrench in toolbox.
7. Remove chocks (WP 0005 00).

END OF WORK PACKAGE

DRUM SCRAPER SERVICE

0023 00**THIS WORK PACKAGE COVERS**Cleaning and Inspection, Adjustment

INITIAL SETUP**Tools and Special Tools**

- Socket, socket wrench (Item 3, WP 0027 00)
- Handle, socket wrench (Item 7, WP 0027 00)

Materials/Parts

- Rag, wiping (Item 16, WP 0029 00)

Equipment Condition

- Roller parked on level ground (WP 0005 00)
 - Drums chocked (WP 0005 00)
 - Engine off (WP 0005 00)
-

NOTE

There are four scraper assemblies located on front and rear of each drum. All scraper assemblies are serviced the same way. This work package covers one CB534B Roller scraper assembly. The CB534C Roller scraper assembly is serviced the same way, except as noted.

CLEANING AND INSPECTION

1. Wipe scraper with clean rag.
2. Inspect scraper for cracks or chips. If damaged, notify supervisor.
3. Adjust scraper pressure. Refer to *Adjustment* in this work package.

ADJUSTMENT**NOTE**

A small amount of pressure on the scraper is required.

1. Remove 3/4 in. socket and 1/2 in. drive ratchet from toolbox.
2. Install 3/4 in. socket on ratchet.

NOTE

There are four locknuts on the CB534C Roller.

3. Loosen eight bolts (1) two full turns.
4. Loosen eight bolts (2).
5. Position scraper (3) so that scraper (3) contacts drum (4) surface firmly and evenly from end to end without bending.
6. Tighten eight bolts (1) and bolts (2) from center of scraper outward while applying downward pressure on spring (5) to ensure a small amount of pressure on the scraper.
7. Remove 3/4 in. socket from ratchet and stow both tools in toolbox.
8. Remove chocks (WP 0005 00).

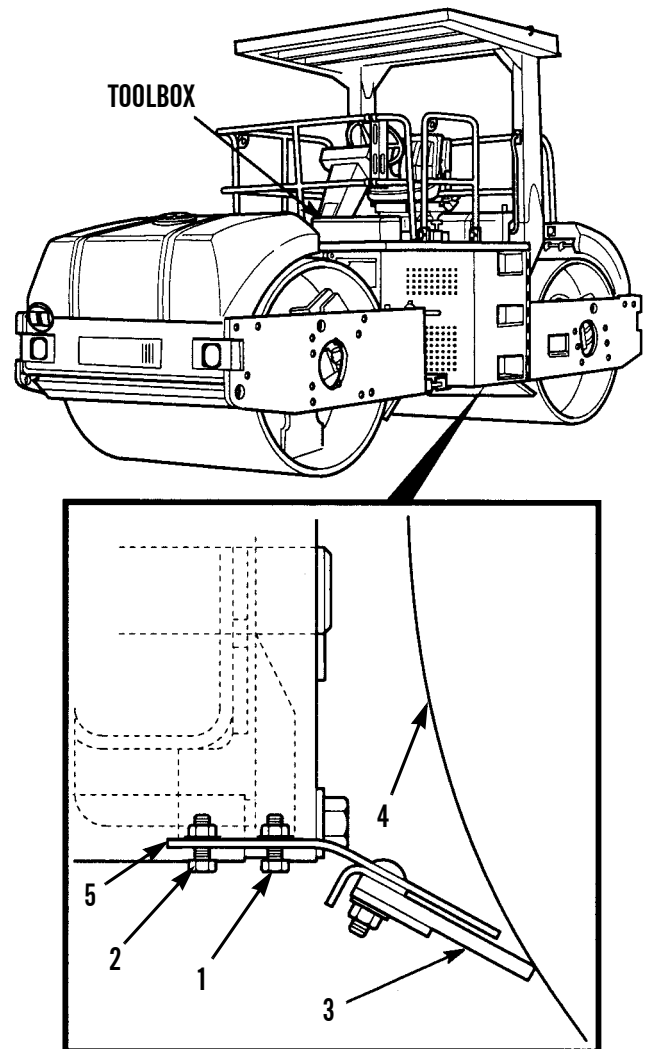

401-111

END OF WORK PACKAGE

THIS WORK PACKAGE COVERS

Check Water Level, Drain and Flush Water Spray System, Fill Water Tank

INITIAL SETUP

Materials/Parts

- Cleaning compound, solvent (Item 3, WP 0029 00)
- Rag, wiping (Item 16, WP 0029 00)

Equipment Condition

- Engine off (WP 0005 00)
- Roller parked on level ground (WP 0005 00)
- Drums chocked (WP 0005 00)

NOTE

- Water spray system is checked and serviced in a similar way for CB534B and CB534C Rollers. CB534B Roller is shown. Differences in the CB534C Roller will be pointed out as they occur.
- The water spray system consists of two identical, but separate systems located at each end of the roller. Each system has seven nozzles on a spray bar.
- This work package covers checking and servicing the front water spray system. The rear water spray system is checked and serviced the same way.

CHECK WATER LEVEL

Check water level gauge (1) located on water tank (2). Fill if necessary.

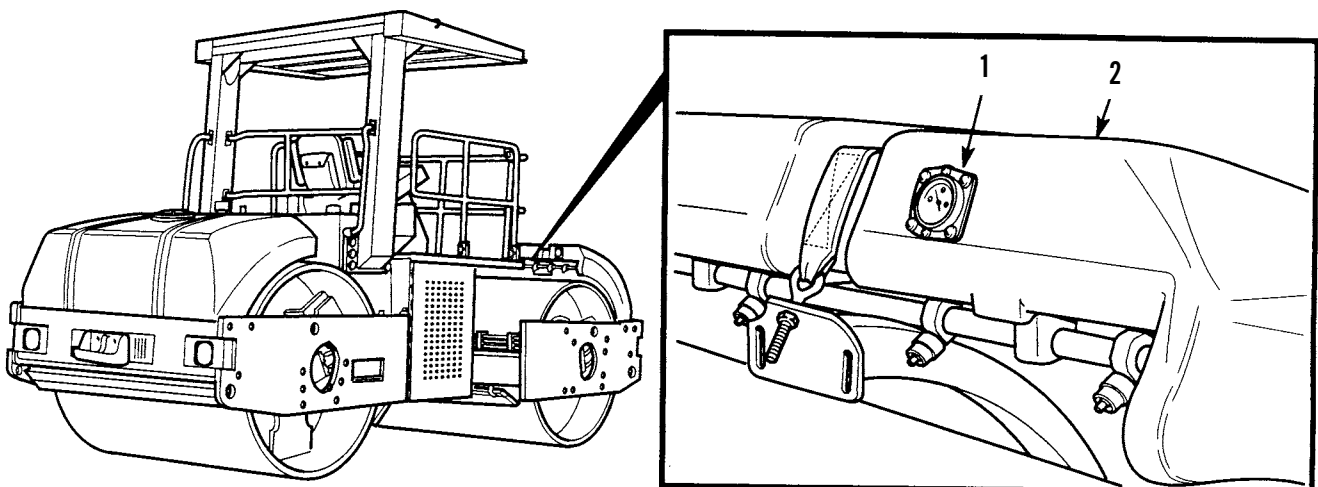

401-112

DRAIN AND FLUSH WATER SPRAY SYSTEM**CAUTION**

Water spray system must be drained at the end of each work day and filled at the beginning of the next work day. Draining ensures the removal of debris or biological growth and prevents damage to the system in the event of freezing temperatures.

NOTE

Steps 1 through 4 cover draining of front water tank. Rear water tank is drained the same way.

1. Turn tee handle on cap assembly (3) counterclockwise until cap assembly can be removed from nipple (4).
2. Allow water to completely drain from water tank (2).

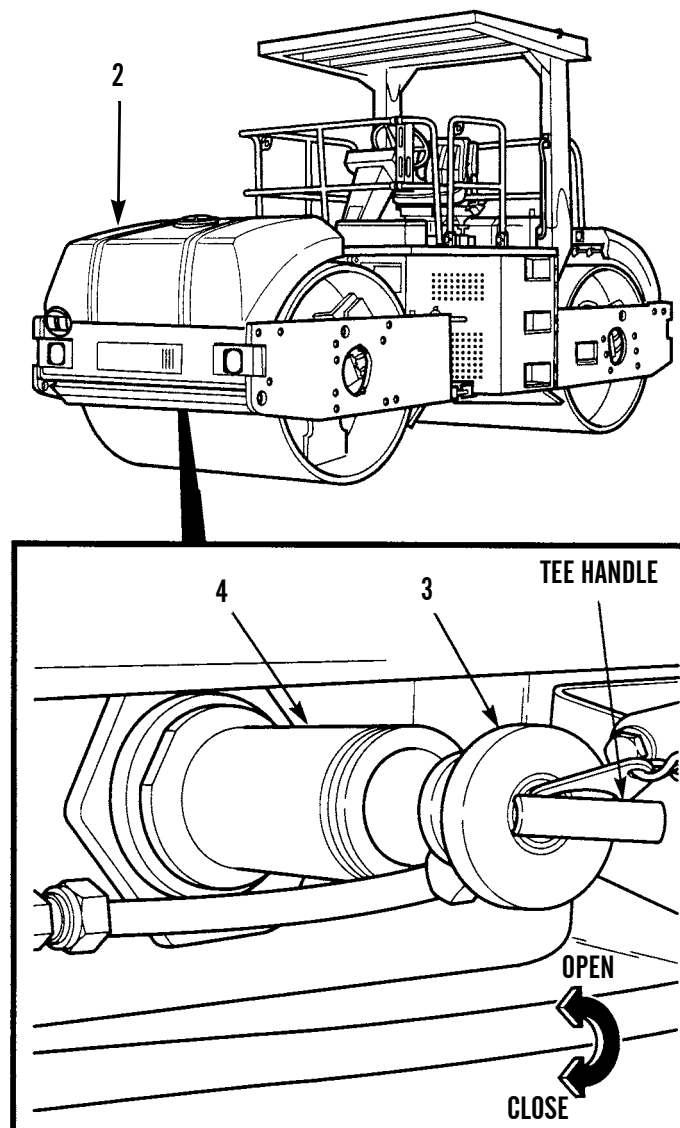

401-113

DRAIN AND FLUSH WATER SPRAY SYSTEM - CONTINUED

- Open drain cock (5) and drain water from line (6).

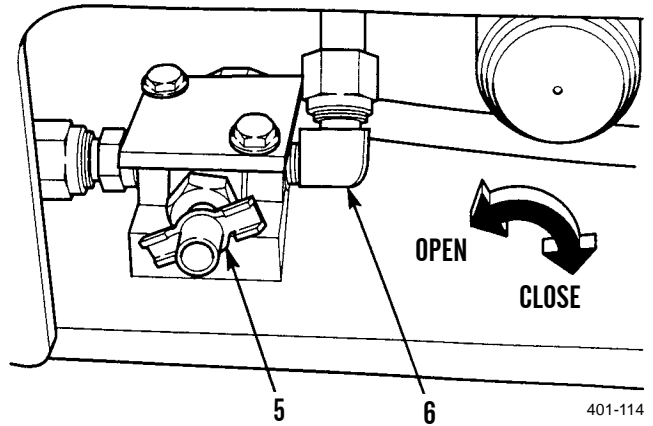

- Remove sediment bowl (7), O-ring (8) and screen (9) from strainer assembly (10) and allow water to drain. Discard O-ring.

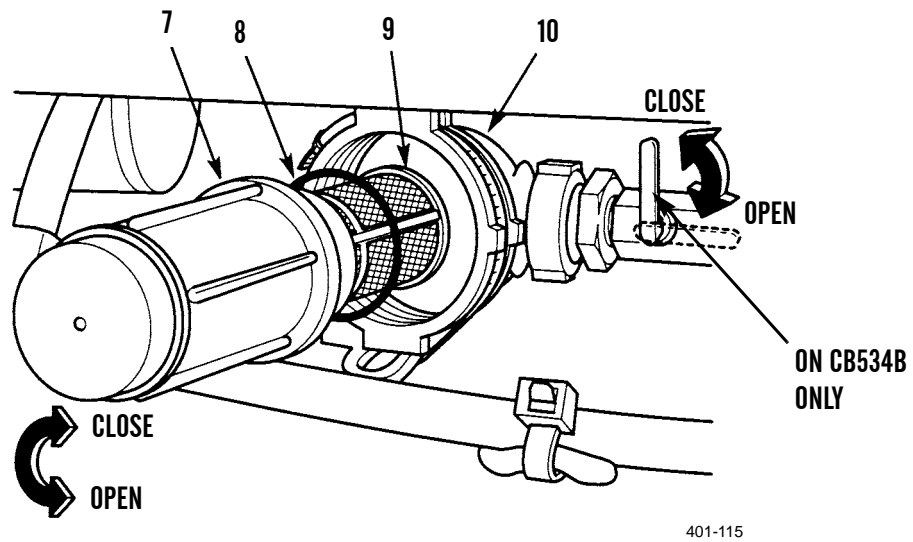

DRAIN AND FLUSH WATER SPRAY SYSTEM - CONTINUED

5. Lift latch (11), pull handle (12) toward front of roller (13), and open right-side door assembly (14) (WP 0005 00).
6. Unhook lanyard (15) from door assembly (14) and hook lanyard to frame assembly (16).
7. Turn valve handle (17) to open position.
8. Open drain cock (18) and drain water from tie line (19).

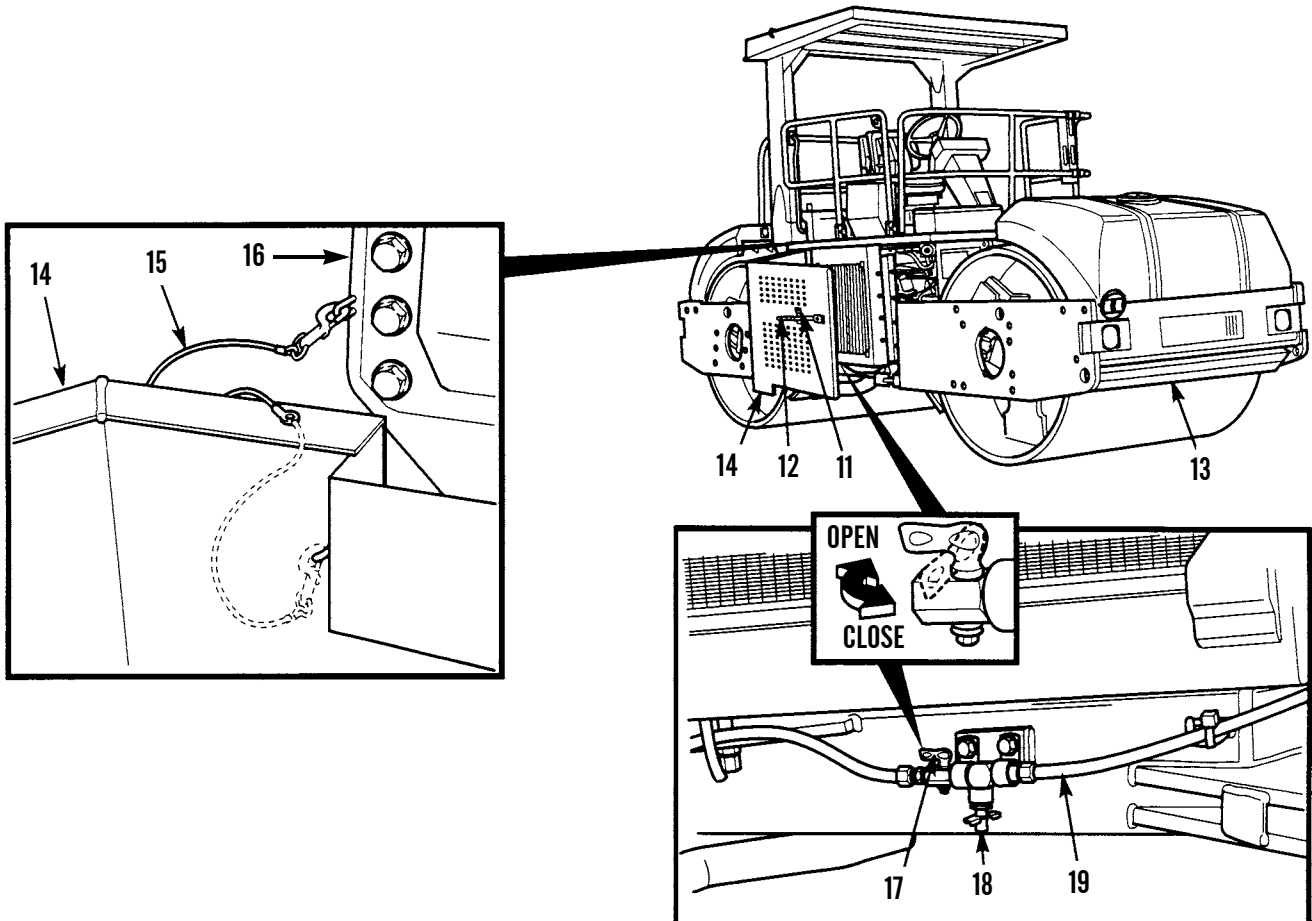

401-116

DRAIN AND FLUSH WATER SPRAY SYSTEM - CONTINUED

9. Turn engine start switch key (20) to ON position.
10. Move water spray switch (21) to continuous spray position for 15 seconds.
11. Move water spray switch (21) to center position.
12. Turn engine start switch key (20) to OFF position.

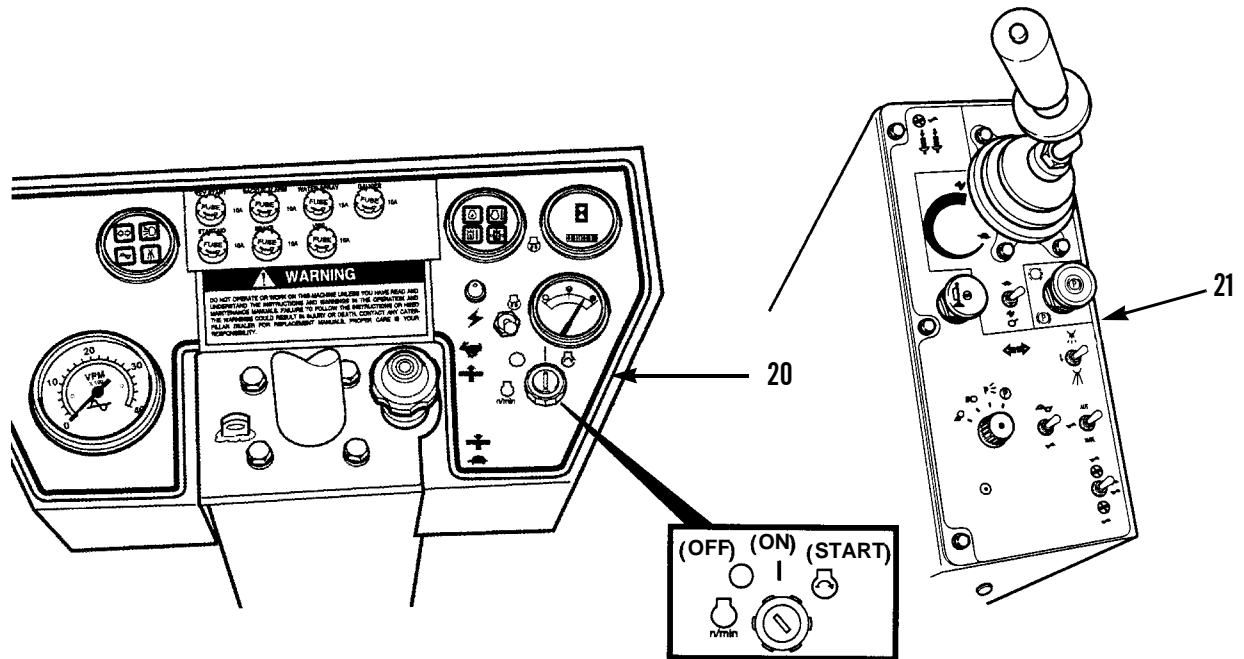

401-042

13. Remove lid (22) from water tank (2).
14. Flush water tank (2) and water spray system with clean water, ensuring that any debris or biological growth is removed from the system.
15. Install lid (22) on water tank (2).

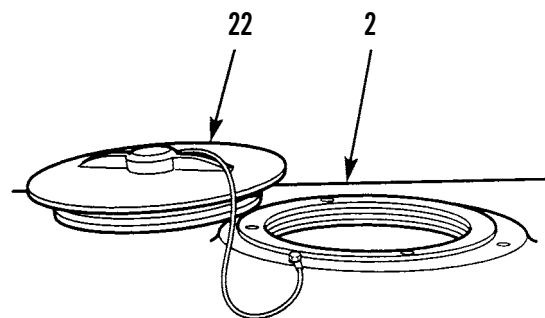

401-117

DRAIN AND FLUSH WATER SPRAY SYSTEM - CONTINUED

16. Close drain cock (18) on tie line (19).
17. Turn valve handle (17) clockwise to close valve.
18. Unhook lanyard (15) from frame assembly (16) and hook lanyard to door assembly (14).
19. Close right-side door assembly (14), push handle (12) into latch (11), and close latch.

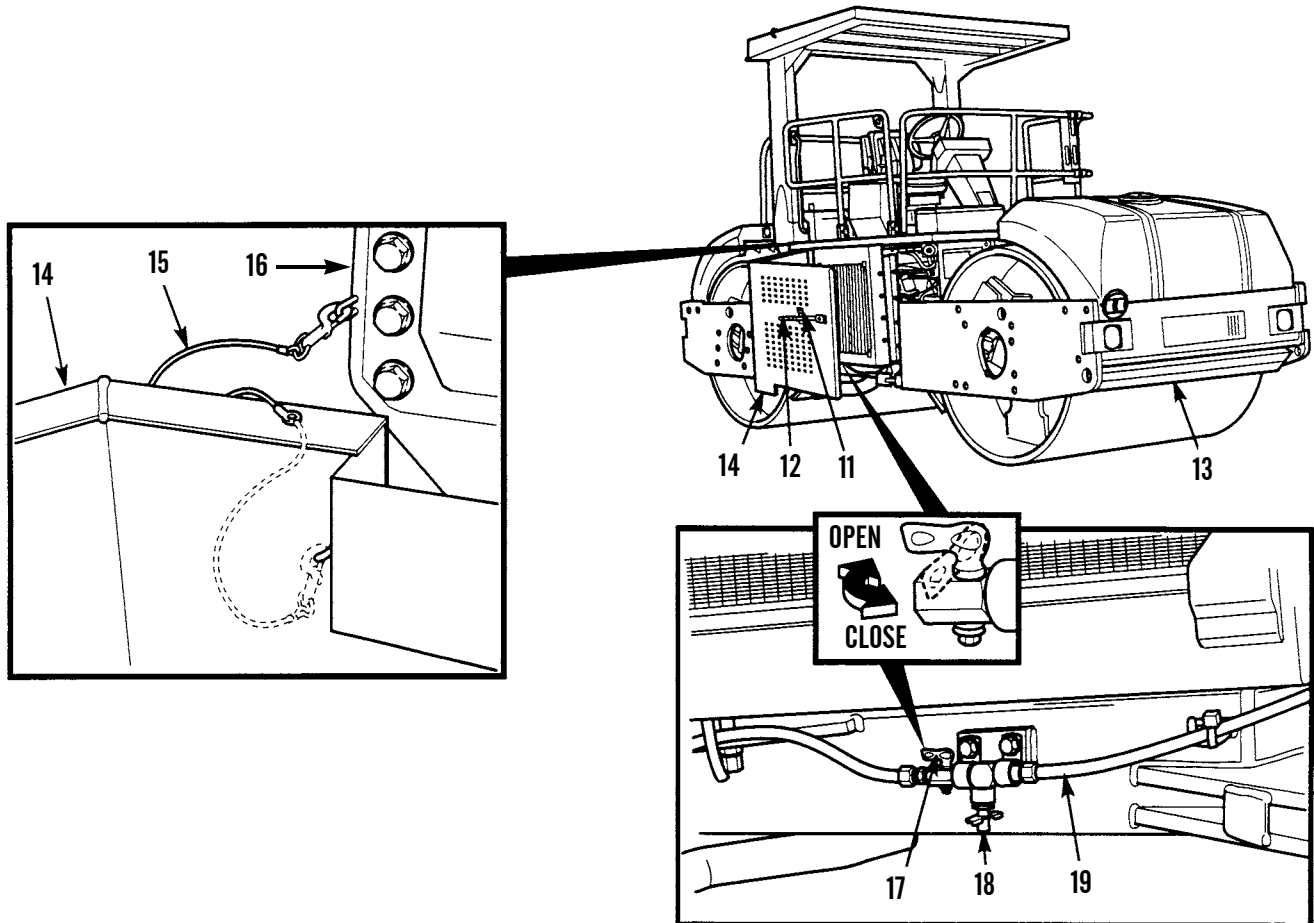

401-116

DRAIN AND FLUSH WATER SPRAY SYSTEM - CONTINUED



WARNING

- Cleaning compound, solvent MIL-PRF-680 Type III is an environmentally compliant and low toxic material. However, it may be irritating to the eyes and skin. Use protective gloves and goggles. Use in well-ventilated areas. Keep away from open flames and other sources of ignition.
- Particles blown by compressed air are hazardous. **DO NOT** exceed 15 psi (103 kPa) nozzle pressure when drying parts with compressed air. Use a maximum of 30 psi (207 kPa) when cleaning components. **DO NOT** direct compressed air against human skin. Failure to follow this warning may result in injury or death. Make sure air stream is directed away from user and other personnel in the area. To prevent injury, user must wear protective goggles or face shield.

20. Clean sediment bowl (7) and screen (8) with solvent cleaning compound.
21. Wipe strainer assembly (10) clean with rag. If any component is damaged, notify supervisor to obtain replacement.
22. Install new O-ring (8), screen (9) and sediment bowl (7) on strainer assembly (10).

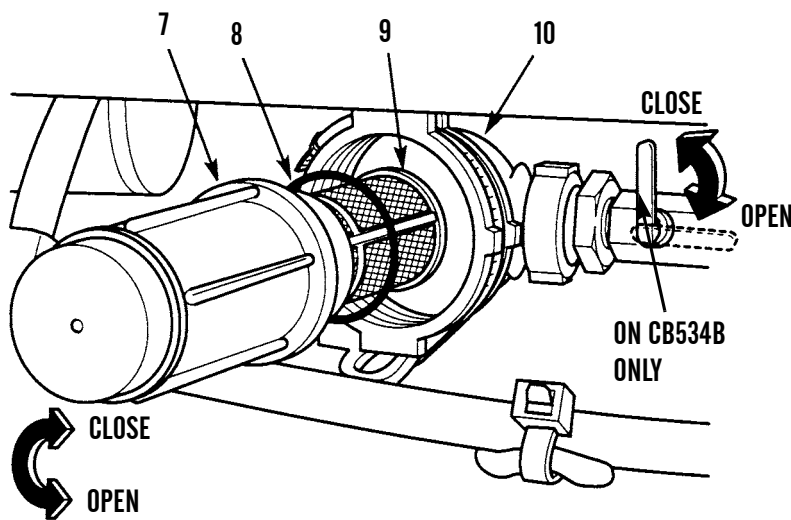

401-115

DRAIN AND FLUSH WATER SPRAY SYSTEM - CONTINUED

23. Insert cap assembly (3) in nipple (4) and turn tee handle clockwise until cap assembly is tightly sealed inside nipple.

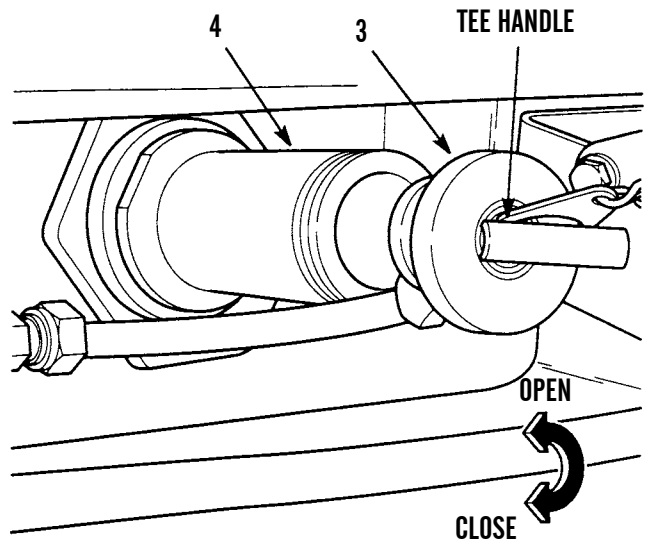

401-118

24. Turn drain cock (5) on line (6) clockwise to close drain cock.

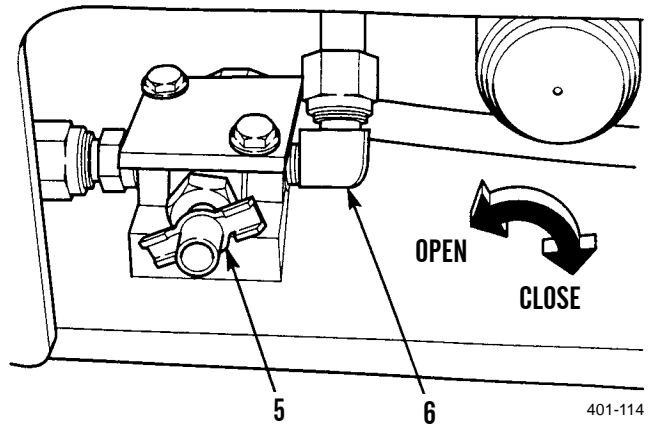

401-114

FILL WATER TANK

1. Remove lid (22) and strainer (23) from water tank (2).
2. Remove any debris from water strainer (23).
3. Install strainer (23) in water tank (2).
4. Fill tank (2) with water.
5. Install lid (22) on tank (2).
6. Remove chocks (WP 0005 00).

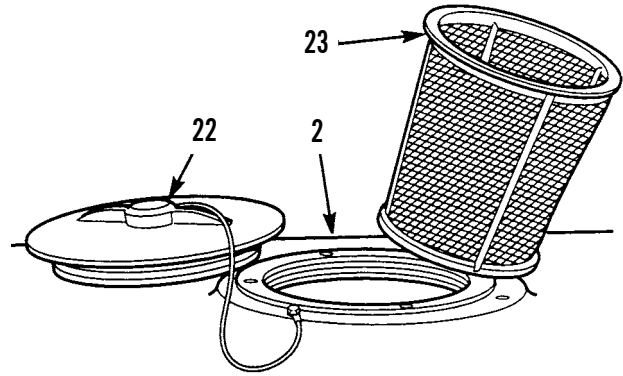

401-119

END OF WORK PACKAGE

THIS WORK PACKAGE COVERS

Removal, Cleaning and Inspection, Installation

INITIAL SETUP

Materials/Parts

- Brush, nylon (Item 2, WP 0029 00)
- Detergent (Item 5, WP 0029 00)
- Rag, wiping (Item 16, WP 0029 00)

Equipment Condition

- Engine off (WP 0005 00)
- Roller parked on level ground (WP 0005 00)
- Drums chocked (WP 0005 00)

NOTE

- The water spray system consists of two identical but separate systems located at each end of the roller. Each system has seven nozzles on a spray bar.
- All water spray nozzles are checked and serviced the same way. This work package covers one nozzle.

REMOVAL

1. Remove cap (1) from clamp (2) by turning cap counterclockwise.
2. Remove screen (3), seal (4) and nozzle (5) from cap (1).

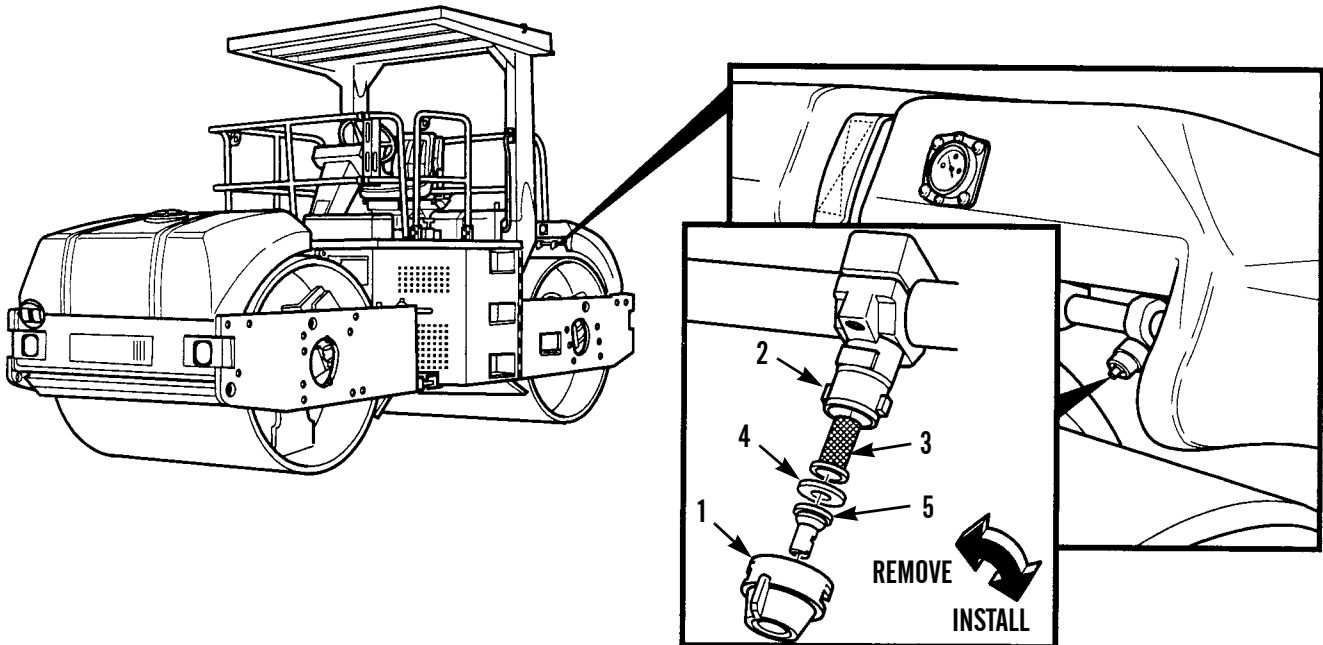

CLEANING AND INSPECTION

1. Clean screen, seal, nozzle and clamp with non-sudsing detergent and water. Remove difficult deposits with a stiff bristle brush.

**WARNING**

Particles blown by compressed air are hazardous. DO NOT exceed 15 psi (103 kPa) nozzle pressure when drying parts with compressed air. Use a maximum of 30 psi (207 kPa) when cleaning components. DO NOT direct compressed air against human skin. Failure to follow this warning may result in injury or death. Make sure air stream is directed away from user and other personnel in the area. To prevent injury, user must wear protective goggles or face shield.

2. Use a cleaning cloth or compressed air to dry metal parts.
3. Check cap and clamp for cracks and wear on locking parts.
4. Check screen for crushing, corrosion or tears.
5. Check seal for cracks, tears or other signs of deterioration.
6. Check nozzle for clogging, corrosion or excessive wear.
7. Notify supervisor for replacement of lost or damaged parts.

INSTALLATION**NOTE**

Slot in nozzle faces down (toward drum surface) when installed.

1. Install nozzle (5), seal (4) and screen (3) in cap (1).

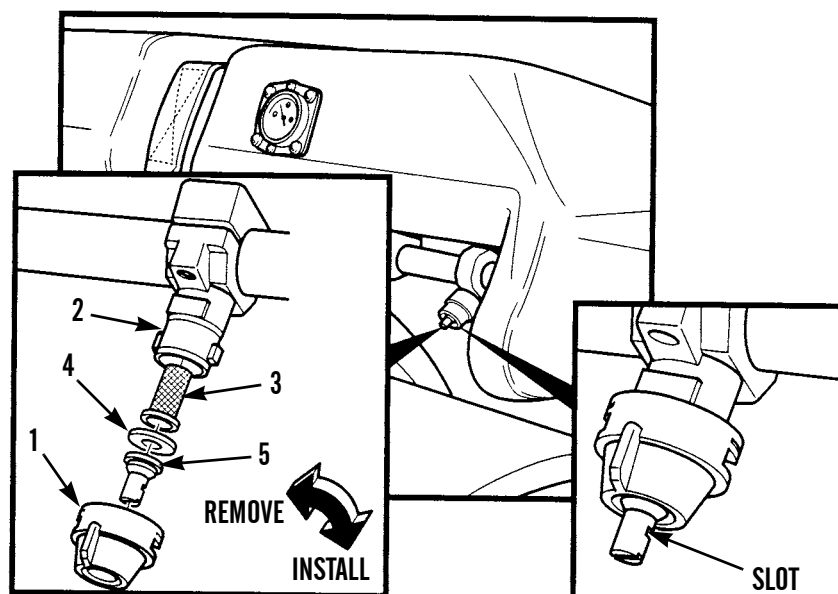

401-121

INSTALLATION - CONTINUED

NOTE

Ensure that cap is securely snapped into locked position. An insecurely installed cap will result in loss of components when water spray system is operated.

2. Install cap (1) on clamp (2) by turning cap clockwise until cap snaps into locked position on clamp.
3. Remove chocks (WP 0005 00).

END OF WORK PACKAGE

CHAPTER 5
SUPPORTING INFORMATION

REFERENCES

0026 00

SCOPE

This work package lists all forms, field manuals, technical bulletins, technical manuals, and other publications referenced in this manual and which apply to the operation of the Roller, Motorized, Vibrating Tandem Steel Drums.

PUBLICATION INDEXES

The following indexes should be consulted frequently for latest changes or revisions and for new publications relating to material covered in this technical manual.

Consolidated Army Publications and Forms Index DA PAM 25-30
 Consolidated Publication of Component Lists EM 0074
 Functional User's Manual for the Army Maintenance Management System DA PAM 738-750
 Using Unit Supply System (Manual Procedures) PAM 710-2-1

FORMS

Refer to DA Pam 738-750, *The Army Maintenance Management System (TAMMS)*, for instructions on the use of maintenance forms.

Equipment Inspection and Maintenance Worksheet DA Form 2404, DA Form 5988-E
 Maintenance Request DA Form 2407
 Organization Control Record for Equipment DA Form 2401
 Preventive Maintenance Schedule and Record DD Form 314
 Product Quality Deficiency Report SF Form 368
 Recommended Changes to Publications and Blank Forms DA Form 2028

UNIT MANUALS

Army Motor Transport Units and Operations FM 55-30
 Basic Cold Weather Manual FM 31-70
 Camouflage, Concealment, and Decoys FM 20-3
 Chemical and Biological Contamination Avoidance FM 3-3
 Desert Operations FM 90-3
 First Aid FM 4-25.11
 NBC Decontamination FM 3-5
 NBC Field Handbook FM 3-7
 Northern Operations FM 31-71
 Nuclear Contamination Avoidance FM 3-3-1
 Operations and Maintenance of Ordnance Materiel in Cold Weather FM 9-207
 Recovery and Battlefield Damage Assessment and Repair FM 9-43-2

TECHNICAL BULLETINS

Color, Marking, and Camouflage Painting of Military Vehicles, Construction Equipment
and Materials Handling Equipment TB 43-0209

Maintenance in the Desert. TB 43-0239

TECHNICAL MANUALS

Procedures for Destruction of Equipment to Prevent Enemy Use (Mobility Equipment Command) TM 750-244-3

Joint Oil Analysis Program Laboratory Manual Vol. I, Introduction, Theory Benefits,
Customer Sampling Procedures, Programs and Reports (TD 33-1-37-1; NAVAIR 17-15-50.1) TM 38-301-1

Materials Used for Cleaning, Preserving, Abrading, and Cementing Ordnance
Materiel and Related Items Including Chemicals. TM 9-247

Operator's, Unit, Direct Support, and General Support Maintenance Manual
for Lead-Acid Storage Batteries. TM 9-6140-200-14

Operator's, Unit, Direct Support, and General Support Maintenance Manual (Including
Repair Parts and Special Tools List) for Semi-Trailer, Lowbed: 40-Ton Construction
Equipment Transporter M870 (CCE) (CMI/Load King Model 403LF)
(NSN 2330-00-133-1731); Semitrailer, Lowbed: 40-Ton Construction Equipment
Transporter M870-A1 (NSN 2330-01-224-9245). TM 5-2330-378-14&P

OTHER PUBLICATIONS

Abbreviations and Acronyms ASME Y14.38-1999

Army Logistics Readiness and Sustainability. AR 700-138

Army Medical Department Expendable/Durable Items CTA 8-100

Expendable/Durable Items (Except Medical, Class V, Repair Parts, and Heraldic Items) CTA 50-970

END OF WORK PACKAGE

SCOPE

This work package lists COEI and BII for the Roller, Motorized, Vibrating Tandem Steel Drums, to help you inventory items required for safe and efficient operation.

GENERAL

The COEI and BII information is divided into the following lists:

1. **Table 1, Components of End Item List.** This listing is for informational purposes only and is not authority to requisition replacements. These items are part of the end item, but are removed and separately packaged for transportation or shipment. As part of the end item, these items must be with the end item whenever it is issued or transferred between property accounts. Illustrations are furnished to assist you in identifying the items.
2. **Table 2, Basic Issue Items List.** These are the minimum essential items required to place the roller in operation, to operate it and to perform emergency repairs. Although shipped separately packaged, BII must be with the roller during operation and whenever it is transferred between property accounts. This manual is your authority to request/requisition replacement BII, based on TOE/MTOE authorization of end item. Illustrations are furnished to assist you in identifying the items.

EXPLANATION OF COLUMNS

Below is an explanation of columns found in the tabular listings:

1. **Column (1) - Illustration Number (Illus Number).** This column indicates the number of the illustration that shows the item.
2. **Column (2) - National Stock Number.** Indicates the National Stock Number (NSN) assigned to the item and will be used for requisitioning purposes.
3. **Column (3) - Description, CAGEC, and Part Number.** Indicates the Federal item name (in all capital letters) and, if required, a minimum description in parentheses to identify and locate the item. The entry for each item ends with the Commercial and Government Entity Code (CAGEC) in parentheses followed by the part number.
4. **Column (4) - Usable on Code.** Indicates a code if the item needed is not the same for different models of equipment. Usable on Codes for the roller are:

<u>Usable On Code</u>	<u>Used On</u>
VRP	CB534B Roller
SWR	CB534C Roller

5. **Column (5) - Unit of Measure (U/M).** Indicates how the item is issued for the National Stock Number shown in Column (2).
6. **Column (6) - Quantity Required (Qty Rqd).** Indicates the quantity of the item required.

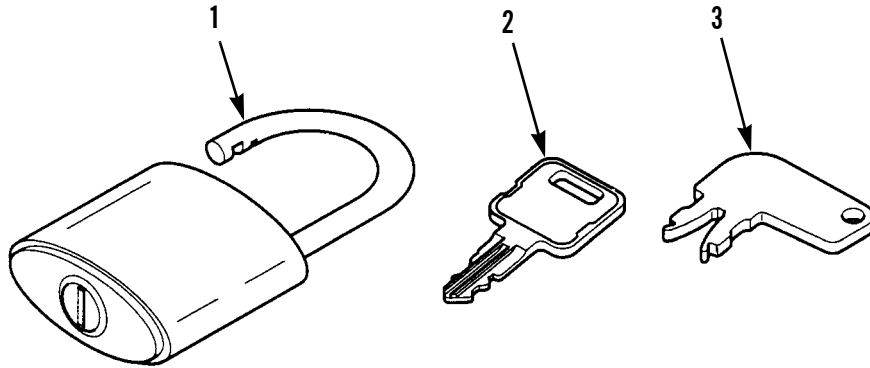

401-122

Table 1. Components of End Item List.

(1) ILLUS NUMBER	(2) NATIONAL STOCK NUMBER	(3) DESCRIPTION, CAGEC, AND PART NUMBER	(4) USABLE ON CODE	(5) U/M	(6) QTY RQD
1	5340-01-181-2579	PADLOCK (11083) 5P-8502	VRP SWR	EA	4
2	5340-01-257-6042	KEY (11083) 5P-8500	VRP SWR	EA	2
3	5930-00-715-1939	KEY, SWITCH (13445) 8398	VRP SWR	EA	1

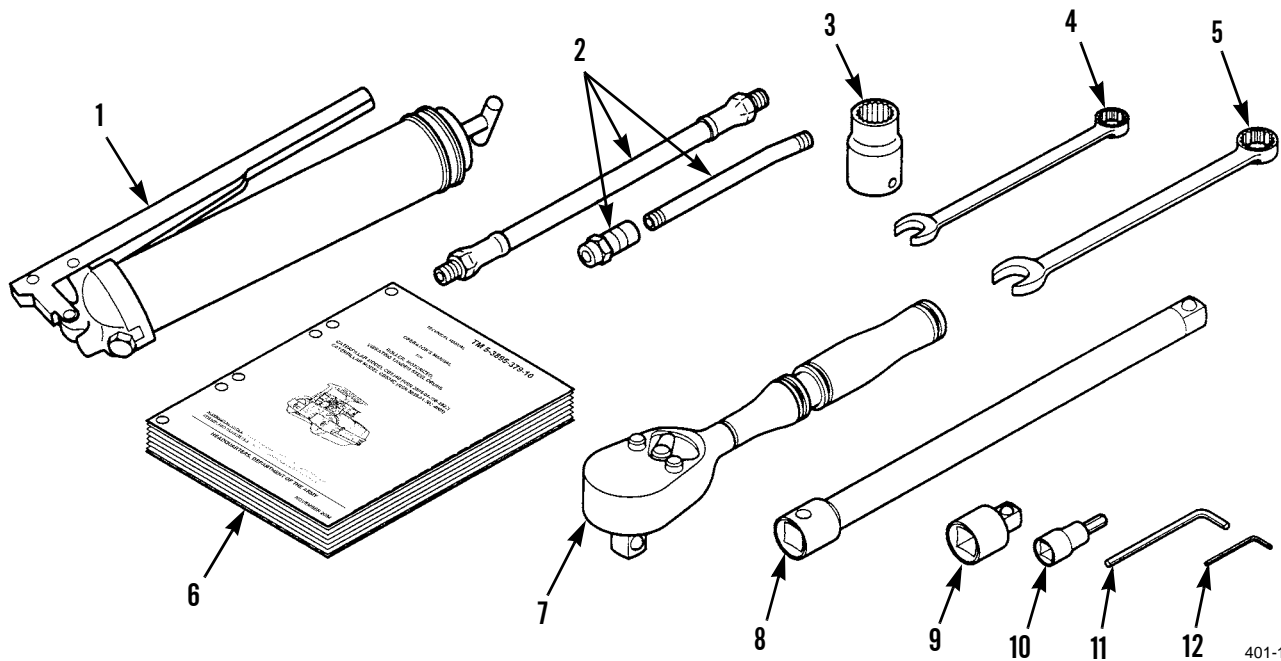

401-123

Table 2. Basic Issue Items List.

(1) ILLUS NUMBER	(2) NATIONAL STOCK NUMBER	(3) DESCRIPTION, CAGEC, AND PART NUMBER	(4) USABLE ON CODE	(5) U/M	(6) QTY RQD
1	4930-00-253-2478	LUBRICATING GUN, HAND (11083) 8F9866	VRP SWR	EA	1
2	4930-00-497-5926	COUPLING, GREASE GUN (Part of 8F9866) (11083) 9F2636	VRP SWR	EA	1
3	5120-00-189-7985	SOCKET, SOCKET WRENCH: TWELVE POINT, 1/2 IN. DRIVE, 3/4 IN. (05506) ST1224	VRP SWR	EA	1
4	5120-01-054-7131	WRENCH, BOX AND OPEN END, COMBINATION: 13 MM (15526) 600-13MMX13MM	VRP SWR	EA	1
5	5120-01-054-7141	WRENCH, BOX AND OPEN END, COMBINATION: 24 MM (05043) BI07.9M	VRP SWR	EA	1
6		OPERATOR'S MANUAL TM 5- 3895-379-10	VRP SWR	EA	1
7	5120-01-355-1902	HANDLE, SOCKET WRENCH: 1/2 IN. DRIVE, 15 IN. LONG (55719) SL936	VRP SWR	EA	1
8	5120-00-227-8107	EXTENSION, SOCKET WRENCH: 3/8 IN. DRIVE, 6 IN. LONG (55719) FX6	VRP SWR	EA	1
9	5120-00-240-8702	ADAPTER, SOCKET WRENCH: 1/2 IN. TO 3/8 IN. DRIVE (39428) 5523A54	VRP SWR	EA	1
10	5120-01-367-3477	SCREWDRIVER ATTACHMENT, SOCKET WRENCH: 5/16 IN, 3/8 IN. DRIVE (55719) FA10E	VRP SWR	EA	1
11	5120-01-045-4889	KEY, SOCKET HEAD SCREW: 4 MM (74445) 57124	VRP SWR	EA	2
12	5120-00-224-2504	KEY, SOCKET HEAD SCREW: 5/64 IN. (88379) ARX132-20	VRP SWR	EA	1

END OF WORK PACKAGE

ADDITIONAL AUTHORIZATION LIST (AAL)

0028 00

SCOPE

This work package lists additional items that you are authorized for support of the Roller, Motorized, Vibrating Tandem Steel Drums.

GENERAL

This list identifies items that do not have to accompany the roller and that do not have to be turned in with it. These items are authorized to you by CTA, MTOE, TDA or JTA.

EXPLANATION OF COLUMNS

1. **Column (1) - National Stock Number.** Indicates the National Stock Number (NSN) assigned to the item and will be used for requisitioning purposes.
2. **Column (2) - Description, CAGEC, and Part Number.** Indicates the Federal item name (in all capital letters) followed by a minimum description when needed. The entry for each item ends with the Commercial and Government Entity Code (CAGEC) in parentheses followed by the part number.
3. **Column (3) - Usable on Code.** Indicates a code if the item needed is not the same for different models of equipment. Usable on Codes for the roller are:

<u>Usable On Code</u>	<u>Used On</u>
VRP	CB534B Roller
SWR	CB534C Roller

4. **Column (4) - Unit of Measure (U/M).** Indicates how the item is issued for the National Stock Number shown in Column (1).
5. **Column (5) - Qty Auth.** Indicates the quantity authorized.

Table 1. Additional Authorization List.

(1)	(2)	(3)	(4)	(5)
NATIONAL STOCK NUMBER	DESCRIPTION, CAGEC, AND PART NUMBER	USABLE ON CODE	U/M	QTY AUTH
4210-00-889-2221	Extinguisher, Fire (16236) CS4210-0008CEFN	VRP SWR	EA	1

END OF WORK PACKAGE

SCOPE

This work package lists expendable and durable items you will need to operate and maintain the Roller, Motorized, Vibrating Tandem Steel Drums. This listing is for informational purposes only and is not authority to requisition the listed items. These items are authorized to you by CTA 50-970, *Expendable/Durable Items (Except Medical, Class V Repair Parts, and Heraldic Items)*, or CTA 8-100, *Army Medical Department Expendable/Durable Items*.

EXPLANATION OF COLUMNS

1. **Column (1) - Item Number.** This number is assigned to the entry in the listing and is referenced in the narrative instructions to identify the item [e.g., Use antifreeze (Item 1, WP 0029 00)].
2. **Column (2) - Level.** This column identifies the lowest level of maintenance that requires the listed item.
C - Operator/Crew
3. **Column (3) - National Stock Number.** This is the National Stock Number assigned to the item which you can use to requisition it.
4. **Column (4) - Description, CAGEC, and Part Number.** This provides the other information you need to identify the item.
5. **Column (5) - Unit of Measure (U/M).** This column shows the physical measurement or count of an item, such as gallon, dozen, gross, etc.

Table 1. Expendable and Durable Items List.

(1) ITEM NUMBER	(2) LEVEL	(3) NATIONAL STOCK NUMBER	(4) DESCRIPTION, CAGEC, AND PART NUMBER	(5) U/M
1	C	6850-01-441-3218	ANTIFREEZE: Permanent Ethylene Glycol, Inhibited, Heavy-Duty (58536) A-A-52624 1 Gallon Can	GAL
		6850-00-181-7933	(81349) MILA46153 5 Gallon Container	GAL
		6850-01-441-3223	(58536) A-A-52624 55 Gallon Drum	GAL
2	C	7920-00-056-5525	BRUSH: Nylon (80020) A408848-2	EA
3	C		CLEANING COMPOUND: Solvent, Type III (81349) MIL-PRF-680	
		6850-01-474-2320 6850-01-474-2321	5 Gallon Can 55 Gallon Drum	GAL GAL
4	C		CLOTH: Cleaning (51200) MIRACLEWIPEL001	
		7920-00-044-9281	10 Pound Bale	LB
5	C		DETERGENT: General Purpose, Liquid (83421) 7930-00-282-9699	
		7930-00-282-9699	1 Gallon Can	GAL
6	C		DIESEL FUEL: DF-1 Grade, Arctic (81346) ASTM D 975	
		9140-00-286-5286	Bulk	GAL
		9140-00-286-5287 9140-00-286-5288	5 Gallon Can 55 Gallon Drum	GAL GAL
7	C		DIESEL FUEL: DF-2 Grade (81346) ASTM D 975	
		9140-00-286-5294	Bulk	GAL
		9140-00-286-5295 9140-00-286-5296	5 Gallon Can 55 Gallon Drum	GAL GAL
8	C	9130-01-031-5816	FUEL, TURBINE: Aviation (81349) MILT83133 GR JP8	GAL

Table 1. Expendable and Durable Items List - Continued.

(1) ITEM NUMBER	(2) LEVEL	(3) NATIONAL STOCK NUMBER	(4) DESCRIPTION, CAGEC, AND PART NUMBER	(5) U/M
9	C	9150-01-197-7688	GREASE: Automotive and Artillery GAA (81349) M-10924-A 1-1/4 Ounce Tube	OZ
		9150-01-197-7693	(81349) M-10924-B 14 Ounce Cartridge	OZ
		9150-01-197-7690	(81349) M-10924-C 1-3/4 Pound Can	LB
		9150-01-197-7692	(81349) M-10924-E 35 Pound Can	LB
10	C	9150-00-402-4478	OIL: Lubricating, Arctic, OEA (81349) MIL-PRF-46167 1 Quart Can	QT
		9150-00-402-2372	(81349) MIL-PRF-46167 5 Gallon Drum	GAL
		9150-00-491-7197	(81349) MIL-PRF-46167 55 Gallon Drum	GAL
11	C	9150-01-035-5390	OIL: Lubricating, GO 75 (81349) MIL-PRF-2105 1 Quart Can	QT
		9150-01-035-5391	5 Gallon Can	GAL
12	C	9150-01-035-5392	OIL: Lubricating, GO 80W/90 (81349) MIL-PRF-2105 1 Quart Can	QT
		9150-00-001-9395	5 Gallon Can	GAL
		9150-01-035-5394	55 Gallon Drum	GAL
13	C	9150-00-189-6727	OIL: Lubricating, OE/HDO 10 (81349) MIL-PRF-2104 1 Quart Can	QT
		9150-00-186-6668	5 Gallon Can	GAL
		9150-00-191-2772	55 Gallon Drum	GAL

EXPENDABLE AND DURABLE ITEMS LIST - CONTINUED

0029 00

Table 1. Expendable and Durable Items List - Continued.

(1) ITEM NUMBER	(2) LEVEL	(3) NATIONAL STOCK NUMBER	(4) DESCRIPTION, CAGEC, AND PART NUMBER	(5) U/M
14	C	9150-01-152-4117	OIL: Lubricating, OE/HYDO 15W/40 (81349) MIL-PRF-2104 1 Quart Can	QT
		9150-01-152-4118	5 Gallon Can	GAL
		9150-01-152-4119	55 Gallon Drum	GAL
15			OIL: Synthetic (ISO 220) (11083) 4C6767 (15958) Syntho Gear EP 220 (19135) SHC 630 1 Quart Can	QT
16	C	7920-00-205-1711	RAG: Wiping (64067) 7920-00-205-1711 50 Pound Bale	LB
17	C	7930-00-634-3935	SOAP: Laundry 200 Pound Container	LB

END OF WORK PACKAGE

INDEX

<i>Subject</i>	<i>Work Package/Page</i>
A	
Abbreviations, List of	0001 00-3
Additional Authorization List (AAL)	0028 00-1
Adjust Handrails for Operation or Stowage	0022 00-1
B	
Basic Issue Items (BII) List	0027 00-1
C	
Chock Drums	0005 00-19
Cleaning Procedures	0013 00-1
Components	
Inspection of	0013 00-1
Removal of	0013 00-1
Components of End Item (COEI) List	0027 00-1
Controls and Indicators	0004 00-2
Corrosion Prevention and Control (CPC)	0001 00-1
D	
Decals, Data Plates, and Stencils	0007 00-2
Decontamination Procedures, Nuclear, Biological and Chemical (NBC)	0006 00-12
Destruction of Army Materiel to Prevent Enemy Use	0001 00-1
Differences Between Models	0002 00-3
Door Assemblies, Opening/Closing	0005 00-20
Drum Scraper Service	0023 00-1
E	
Electrical System, Theory of Operation	0003 00-1
Emergency Procedures	0006 00-3
Engine	
Coolant Check and Service	0017 00-1
Oil Level, Check	0014 00-1
Oil Level, Service	0014 00-2
Operate	0005 00-5
Equipment	
Characteristics, Capabilities, and Features	0002 00-1
Data	0002 00-3
Equipment Improvement Recommendation (EIRs), Reporting	0001 00-1
Expendable and Durable Items List	0029 00-1

INDEX - Continued

Subject *Work Package/Page*

E - Continued

Extreme Cold, Operate in 0006 00-8
 Extreme Heat, Operate in 0006 00-11

F

Fording 0006 00-12
 Front and Rear Propel Gearbox Oil Check and Service (CB534B) 0021 00-1

Fuel

 Fill Tank 0015 00-4
 Filter, Drain 0015 00-2
 Level, Check 0015 00-2
 Tank, Drain 0019 00-1
 Tank, Fill 0019 00-5

Fuel/Water Separator Service 0016 00-1

G

Glossary 0001 00-3

H

Hydraulic

 Oil Level, Check 0018 00-1
 Oil Tank, Drain 0019 00-3
 Oil Tank, Fill 0019 00-4

I

Initial Adjustments and Daily Checks 0005 00-1

Inspection of Components 0013 00-1

L

List

 Abbreviations 0001 00-3
 Additional Authorization List (AAL) 0028 00-1
 Basic Issue Items (BII) 0027 00-1
 Components of End Item (COEI) 0027 00-1

Location and Description of Major Components 0002 00-2

Lubrication

 Chart 0011 00-5
 General Procedures 0011 00-3
 Key 0011 00-4

M

Maintenance Forms, Records, and Reports 0001 00-1

Mount and Dismount Roller 0005 00-4

INDEX - Continued

Subject *Work Package/Page*

M - Continued

Move Roller 0005 00-16

N

Nomenclature Cross-Reference 0001 00-3

Nuclear, Biological and Chemical (NBC) Decontamination Procedures 0006 00-12

O

Opening/Closing Door Assemblies 0005 00-20

Operate

 Engine 0005 00-5

 In Extreme Cold 0006 00-8

 In Extreme Heat 0006 00-11

 In Sandy or Dusty Conditions 0006 00-11

 Vibratory System 0005 00-14

 Water Spray System 0005 00-12

P

Park Roller 0005 00-18

Preparation for Transport 0005 00-22

Preventive Maintenance Checks and Services (PMCS)

 Introduction 0011 00-1

 Table 0012 00-1

Propel System, Theory of Operation 0003 00-2

R

References 0026 00-1

Removal of Components 0013 00-1

Reporting Equipment Improvement Recommendations (EIRs) 0001 00-1

Roading Machine 0005 00-21

Roller

 Mount and Dismount 0005 00-4

 Park 0005 00-18

 Slave Start 0006 00-1

Rolling Procedures 0005 00-17

S

Sandy or Dusty Conditions, Operate in 0006 00-11

Slave Start Roller 0006 00-1

Steering System, Theory of Operation 0003 00-3

Stowage Guide 0007 00-1

INDEX - Continued

<i>Subject</i>	<i>Work Package/Page</i>
T	
Theory of Operation	
Basic Operation	0003 00-1
Electrical System	0003 00-1
Propel System	0003 00-2
Steering System	0003 00-3
Vibratory System	0003 00-4
Water Spray System	0003 00-5
Towing Instructions	0005 00-21
Transport, Preparation for	0005 00-22
Troubleshooting	
Instructions	0008 00-1
Procedures	0010 00-1
Symptom Index	0009 00-1
V	
Vibratory	
Bearing Reservoir	
Check	0020 00-1
Fill	0020 00-2
System	
Operate	0005 00-14
Theory of Operation	0003 00-4
W	
Warranty Information	0001 00-1
Water Spray	
Nozzle Check and Service	0025 00-1
System	
Check and Service	0024 00-1
Operate	0005 00-12
Theory of Operation	0003 00-5

By Order of the Secretary of the Army:

PETER J. SCHOOMAKER
General, United States Army
Chief of Staff

Official:

SANDRA R. RILEY
Administrative Assistant to the
Secretary of the Army
0515802

DISTRIBUTION: To be distributed in accordance with the initial distribution requirements for IDN: 256608, requirements for TM 5-3895-379-10.

<p>RECOMMENDED CHANGES TO PUBLICATIONS AND BLANK FORMS</p> <p>For use of this form, see AR 25-30; the proponent agency is OAASA</p>	<p>Use Part II (<i>reverse</i>) for Repair Parts and Special Tool Lists (RPSTL) and Supply Catalogs/Supply Manuals (SC/SM).</p>	<p>DATE</p> <p>1 July 2005</p>
--	---	---------------------------------------

<p>TO: (<i>Forward to proponent of publication or form</i>) (<i>Include ZIP Code</i>)</p>	<p>FROM: (<i>Activity and location</i>) (<i>Include ZIP Code</i>)</p>
--	--

PART I - ALL PUBLICATIONS (EXCEPT RPSTL AND SC/SM) AND BLANK FORMS

<p>PUBLICATION/FORM NUMBER</p> <p>TM 5-3895-379-10</p>	<p>DATE</p> <p>15 July 2005</p>	<p>TITLE Operator's Manual for Roller, Motorized, Vibrating Tandem Steel Drums, Models CB534B and CB534C</p>
--	---------------------------------	--

ITEM	PAGE	PARA-	LINE	FIGURE NO.	TABLE	RECOMMENDED CHANGES AND REASON
	0017 00-2					<p>Part number supplied for item 2 is incorrect.</p>

SAMPLE

<p>TYPED NAME, GRADE OR TITLE</p>	<p>TELEPHONE EXCHANGE/AUTOVON, PLUS EXTENSION</p>	<p>SIGNATURE</p>
-----------------------------------	---	------------------

TO: <i>(Forward direct to addressee listed in publication)</i>	FROM: <i>(Activity and location) (Include ZIP Code)</i>	DATE
---	--	-------------

PART II - REPAIR PARTS AND SPECIAL TOOL LISTS AND SUPPLY CATALOGS/SUPPLY MANUALS

PUBLICATION NUMBER			DATE	TITLE				
PAGE NO.	COLM NO.	LINE NO.	NATIONAL STOCK NUMBER	REFERENCE NO.	FIGURE NO.	ITEM NO.	TOTAL NO. OF MAJOR ITEMS SUPPORTED	RECOMMENDED ACTION
SAMPLE								

PART III - REMARKS *(Use for general remarks, references, or suggestions for improvement of publications and catalogs. Additional sheets may be used if space is needed.)*

TYPED NAME, GRADE OR TITLE	TELEPHONE EXCHANGE/AUTOVON, PLUS EXTENSION	SIGNATURE
----------------------------	--	-----------

RECOMMENDED CHANGES TO PUBLICATIONS AND BLANK FORMS For use of this form, see AR 25-30; the proponent agency is OAASA						Use Part II (<i>reverse</i>) for Repair Parts and Special Tool Lists (RPSTL) and Supply Catalogs/Supply Manuals (SC/SM).	DATE
TO: (<i>Forward to proponent of publication or form</i>) (<i>Include ZIP Code</i>)						FROM: (<i>Activity and location</i>) (<i>Include ZIP Code</i>)	
PART I - ALL PUBLICATIONS (EXCEPT RPSTL AND SC/SM) AND BLANK FORMS							
PUBLICATION/FORM NUMBER TM 5-3895-379-10						DATE 15 July 2005	TITLE Operator's Manual for Roller, Motorized, Vibrating Tandem Steel Drums, Models CB534B and CB534C
ITEM	PAGE	PARA-	LINE	FIGURE NO.	TABLE	RECOMMENDED CHANGES AND REASON	
TYPED NAME, GRADE OR TITLE					TELEPHONE EXCHANGE/AUTOVON, PLUS EXTENSION		SIGNATURE

TO: <i>(Forward direct to addressee listed in publication)</i>	FROM: <i>(Activity and location) (Include ZIP Code)</i>	DATE
---	--	-------------

PART II - REPAIR PARTS AND SPECIAL TOOL LISTS AND SUPPLY CATALOGS/SUPPLY MANUALS

PUBLICATION NUMBER			DATE	TITLE				
PAGE NO.	COLM NO.	LINE NO.	NATIONAL STOCK NUMBER	REFERENCE NO.	FIGURE NO.	ITEM NO.	TOTAL NO. OF MAJOR ITEMS SUPPORTED	RECOMMENDED ACTION

PART III - REMARKS *(Any general remarks or recommendations, or suggestions for improvement of publications and blank forms. Additional blank sheets may be used if more space is needed.)*

TYPED NAME, GRADE OR TITLE	TELEPHONE EXCHANGE/AUTOVON, PLUS EXTENSION	SIGNATURE
----------------------------	--	-----------

RECOMMENDED CHANGES TO PUBLICATIONS AND BLANK FORMS For use of this form, see AR 25-30; the proponent agency is OAASA						Use Part II (<i>reverse</i>) for Repair Parts and Special Tool Lists (RPSTL) and Supply Catalogs/Supply Manuals (SC/SM).	DATE
TO: (<i>Forward to proponent of publication or form</i>) (<i>Include ZIP Code</i>)						FROM: (<i>Activity and location</i>) (<i>Include ZIP Code</i>)	
PART I - ALL PUBLICATIONS (EXCEPT RPSTL AND SC/SM) AND BLANK FORMS							
PUBLICATION/FORM NUMBER TM 5-3895-379-10						DATE 15 July 2005	TITLE Operator's Manual for Roller, Motorized, Vibrating Tandem Steel Drums, Models CB534B and CB534C
ITEM	PAGE	PARA-	LINE	FIGURE NO.	TABLE	RECOMMENDED CHANGES AND REASON	
TYPED NAME, GRADE OR TITLE					TELEPHONE EXCHANGE/AUTOVON, PLUS EXTENSION		SIGNATURE

TO: <i>(Forward direct to addressee listed in publication)</i>	FROM: <i>(Activity and location) (Include ZIP Code)</i>	DATE
---	--	-------------

PART II - REPAIR PARTS AND SPECIAL TOOL LISTS AND SUPPLY CATALOGS/SUPPLY MANUALS

PUBLICATION NUMBER			DATE	TITLE				
PAGE NO.	COLM NO.	LINE NO.	NATIONAL STOCK NUMBER	REFERENCE NO.	FIGURE NO.	ITEM NO.	TOTAL NO. OF MAJOR ITEMS SUPPORTED	RECOMMENDED ACTION

PART III - REMARKS *(Any general remarks or recommendations, or suggestions for improvement of publications and blank forms. Additional blank sheets may be used if more space is needed.)*

TYPED NAME, GRADE OR TITLE	TELEPHONE EXCHANGE/AUTOVON, PLUS EXTENSION	SIGNATURE
----------------------------	--	-----------

RECOMMENDED CHANGES TO PUBLICATIONS AND BLANK FORMS For use of this form, see AR 25-30; the proponent agency is OAASA						Use Part II (<i>reverse</i>) for Repair Parts and Special Tool Lists (RPSTL) and Supply Catalogs/Supply Manuals (SC/SM).	DATE
TO: (<i>Forward to proponent of publication or form</i>) (<i>Include ZIP Code</i>)						FROM: (<i>Activity and location</i>) (<i>Include ZIP Code</i>)	
PART I - ALL PUBLICATIONS (EXCEPT RPSTL AND SC/SM) AND BLANK FORMS							
PUBLICATION/FORM NUMBER TM 5-3895-379-10						DATE 15 July 2005	TITLE Operator's Manual for Roller, Motorized, Vibrating Tandem Steel Drums, Models CB534B and CB534C
ITEM	PAGE	PARA-	LINE	FIGURE NO.	TABLE	RECOMMENDED CHANGES AND REASON	
TYPED NAME, GRADE OR TITLE					TELEPHONE EXCHANGE/AUTOVON, PLUS EXTENSION		SIGNATURE

TO: <i>(Forward direct to addressee listed in publication)</i>	FROM: <i>(Activity and location) (Include ZIP Code)</i>	DATE
---	--	-------------

PART II - REPAIR PARTS AND SPECIAL TOOL LISTS AND SUPPLY CATALOGS/SUPPLY MANUALS

PUBLICATION NUMBER			DATE			TITLE		
PAGE NO.	COLM NO.	LINE NO.	NATIONAL STOCK NUMBER	REFERENCE NO.	FIGURE NO.	ITEM NO.	TOTAL NO. OF MAJOR ITEMS SUPPORTED	RECOMMENDED ACTION

PART III - REMARKS *(Any general remarks or recommendations, or suggestions for improvement of publications and blank forms. Additional blank sheets may be used if more space is needed.)*

TYPED NAME, GRADE OR TITLE	TELEPHONE EXCHANGE/AUTOVON, PLUS EXTENSION	SIGNATURE
----------------------------	--	-----------

THE METRIC SYSTEM AND EQUIVALENTS

<p>Linear Measure</p> <p>1 Centimeter = 10 Millimeters = 0.01 Meters = 0.3937 Inches 1 Meter = 100 Centimeters = 1000 Millimeters = 39.37 Inches 1 Kilometer = 1000 Meters = 0.621 Miles</p> <p>Weights</p> <p>1 Gram = 0.001 Kilograms = 1000 Milligrams = 0.035 Ounces 1 Kilogram = 1000 Grams = 2.2 Pounds 1 Metric Ton = 1000 Kilograms = 1 Megagram = 1.1 Short Tons</p> <p>Liquid Measure</p> <p>1 Milliliter = 0.001 Liters = 0.0338 Fluid Ounces 1 Liter = 1000 Milliliters = 33.82 Fluid Ounces</p>	<p>Square Measure</p> <p>1 Sq Centimeter = 100 Sq Millimeters = 0.155 Sq Inches 1 Sq Meter = 10,000 Sq Centimeters = 10.76 Sq Feet 1 Sq Kilometer = 1,000,000 Sq Meters = 0.386 Sq Miles</p> <p>Cubic Measure</p> <p>1 Cu Centimeter = 1,000 Cu Millimeters = 0.06 Cu Inches 1 Cu Meter = 1,000,000 Cu Centimeters = 35.31 Cu Feet</p> <p>Temperature</p> <p>$5/9 (^{\circ}\text{F} - 32) = ^{\circ}\text{C}$ 212° Fahrenheit is equivalent to 100° Celsius 90° Fahrenheit is equivalent to 32.2° Celsius 32° Fahrenheit is equivalent to 0° Celsius $9/5 \text{ C}^{\circ} + 32 = \text{F}^{\circ}$</p>
--	--

APPROXIMATE CONVERSION FACTORS

To Change	To	Multiply By
Inches	Centimeters	2.540
Feet	Meters	0.305
Yards	Meters	0.914
Miles	Kilometers	1.609
Sq Inches	Sq Centimeters	6.451
Sq Feet	Sq Meters	0.093
Sq Yards	Sq Meters	0.836
Sq Miles	Sq Kilometers	2.590
Acres	Sq Hectometers	0.405
Cubic Feet	Cubic Meters	0.028
Cubic Yards	Cubic Meters	0.765
Fluid Ounces	Milliliters	29.573
Pints	Liters	0.473
Quarts	Liters	0.946
Gallons	Liters	3.785
Ounces	Grams	28.349
Pounds	Kilograms	0.454
Short Tons	Metric Tons	0.907
Pound-Feet	Newton-Meters	1.356
Pounds per Sq Inch	Kilopascals	6.895
Miles per Gallon	Kilometers per Liter	0.425
Miles per Hour	Kilometers per Hour	1.609

To Change	To	Multiply By
Centimeters	Inches	0.394
Meters	Feet	3.280
Meters	Yards	1.094
Kilometers	Miles	0.621
Sq Centimeters	Sq Inches	0.155
Sq Meters	Sq Feet	10.764
Sq Meters	Sq Yards	1.196
Sq Kilometers	Sq Miles	0.386
Sq Hectometers	Acres	2.471
Cubic Meters	Cubic Feet	35.315
Cubic Meters	Cubic Yards	1.308
Milliliters	Fluid Ounces	0.034
Liters	Pints	2.113
Liters	Quarts	1.057
Liters	Gallons	0.264
Grams	Ounces	0.035
Kilograms	Pounds	2.205
Metric Tons	Short Tons	1.102
Newton-Meters	Pound-Feet	0.738
Kilopascals	Pounds per Sq Inch	0.145
Kilometers per Liter	Miles per Gallon	2.354
Kilometers per Hour	Miles per Hour	0.621

This fine document...

Was brought to you by me:



[Liberated Manuals -- free army and government manuals](#)

Why do I do it? I am tired of sleazy CD-ROM sellers, who take publicly available information, slap “watermarks” and other junk on it, and sell it. Those masters of search engine manipulation make sure that their sites that sell free information, come up first in search engines. They did not create it... They did not even scan it... Why should they get your money? Why are not letting you give those free manuals to your friends?

I am setting this document FREE. This document was made by the US Government and is NOT protected by Copyright. Feel free to share, republish, sell and so on.

I am not asking you for donations, fees or handouts. If you can, please provide a link to liberatedmanuals.com, so that free manuals come up first in search engines:

<A HREF=<http://www.liberatedmanuals.com/>>Free Military and Government Manuals

- Sincerely
Igor Chudov
<http://igor.chudov.com/>
- [Chicago Machinery Movers](#)