

TP2009

# Student Workbook



# FREIGHT CAR DRAFT ARRANGEMENTS



February 2003

---

## Disclaimer

Thank you for making Wabtec Corporation your choice for educational material.

All our training publications are designed as teaching tools for a specific area of railway equipment instruction. As with any training literature, it will eventually become out of date. For this reason, it is important that only the current edition of this training package be used. To ensure you have the current edition please contact your Wabtec representative. Wabtec Corporation produces a line of instructional pamphlets and brochures for each of the components that Wabtec manufactures to help augment the training process. This publication is under copyright to the Wabtec Corporation. Any reproduction in whole or in part without written consent from an officer of Wabtec Corporation is strictly prohibited.

This book may contain information covering some products manufactured by companies other than Wabtec. This is done to give you, the user, an opportunity to utilize one manual for the majority of your training requirements.

Information covering products not supplied by Wabtec Corporation is provided as a general guide as to how these products should perform. Wabtec Corporation accepts no responsibility for the operation of products supplied by others, nor the information stated herein as to design or intended dimensional limits of such products.

Technical questions on the equipment shown in this booklet should be directed to the original manufacturer. If there are any discrepancies between this book and the original manufacturer standards, the original manufacturer instructions take precedence.

Wabtec Corporation accepts no responsibility for injury or damage to personnel or equipment resulting from either direct or indirect use of this manual.

For Technical Support contact your local Wabtec Corporation representative or Wabtec Training in Wilmerding, Pennsylvania, USA at 412-825-1453.

***Michael Zenert***  
(Michael Zenert)  
Manager - Air Brake Training  
Wabtec Corporation

© 2003 Wabtec Corporation

## Contents

<b>Part 1: Introduction .....</b>	<b>3</b>
<b>Part 2: Draft Gear Components .....</b>	<b>3</b>
A. Coupler .....	3
B. Follower Block or Plate .....	4
C. Draft Gear: .....	4
D. Coupler Yoke .....	5
E. Draft Gear Pocket .....	5
F. Draft Gear Carrier or Carrier Iron .....	5
G. Draft Key or Cross Key .....	5
H. Draft Key (Cross Key) Retainer .....	5
I. Draft Gear Lugs .....	6
J. Striker Casting .....	6
<b>Part 3: Overview of the Draft Gear Connection and Components .....</b>	<b>7</b>
<b>Part 4: End of Car Cushioning and Cushion Underframes .....</b>	<b>9</b>
A. End-of-Car Cushioning .....	9
B. Cushioned Underframe .....	9
<b>Part 5: Internal Operation of a Draft Gear .....</b>	<b>10</b>
Cardwell Westinghouse Draft Gears .....	10
1. Mark 325 .....	10
2. Mark 50 and Mark 500 .....	11
3. Mark H-60 .....	12
<b>Part 6: Articulated Connectors .....</b>	<b>13</b>
A. Cardwell Westinghouse SAC-1 Connector .....	13
B. ASF Articulated Connectors .....	17
C. National Articulated Connector .....	18
<b><i>Review Exercise .....</i></b>	<b>19</b>

## Part 1: Introduction

The movement of railway equipment involves heavy pulling and pushing forces to move the weight of the cars as the train moves. This buffing and pulling action between each car and locomotive occurs each time the equipment moves. To ensure the car(s) and locomotive(s) can accept this movement without causing damage to the equipment and/or lading, the equipment must have a system to absorb this punishment. The draft system is designed like a large shock absorber to accept the impact of car movement without resulting in equipment or lading damage. With the use of a draft system trains hauling many tons of consumer products and over a mile in length are possible. This workbook is designed for the draft arrangements associated with freight cars. Locomotive draft systems are similar but are not covered in this booklet.

## Part 2: Draft Gear Components

### A. Coupler

The coupler is a large metal casting used for the connection of cars and locomotives. There are many couplers identified in the AAR Rules, however, they are generally considered as Type E, F or E/F in design. The type of coupler required depends upon the type of car and its use.

The E type couplers have an E-type head with a horizontal slot through which the draft or cross key passes. They are a common coupler used on hopper cars, box cars and flat cars. See AAR Rule 16 for wear limits and interchange requirements.

The F-Type coupler has a larger head with interlocking wings on the side and the key opening is vertical requiring a pin to connect with the yoke. The F-type couplers are typically used on tank cars and coal cars. See AAR Rule 17 for wear limits and interchange requirements.

The E/F design coupler uses an E type head with a vertical pin connection. It is typically used on flat cars with end of car cushioning units.

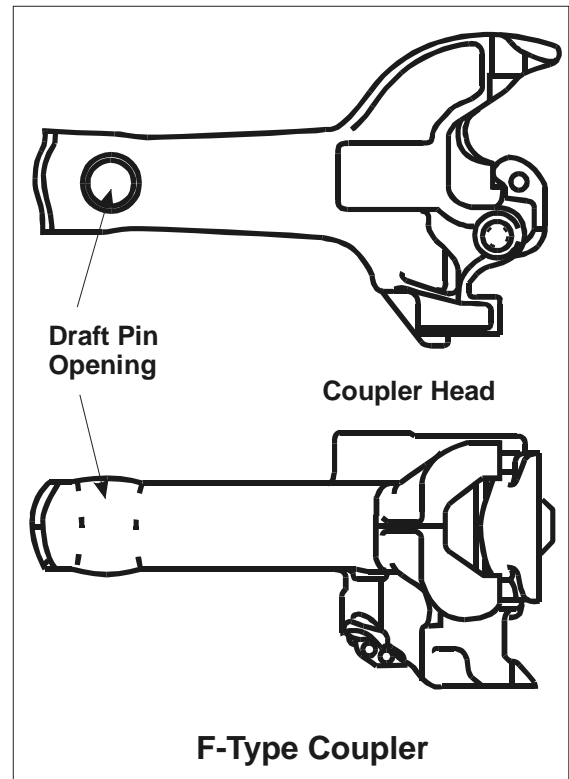
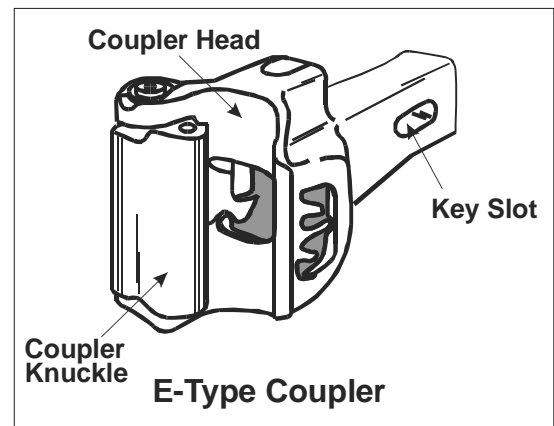

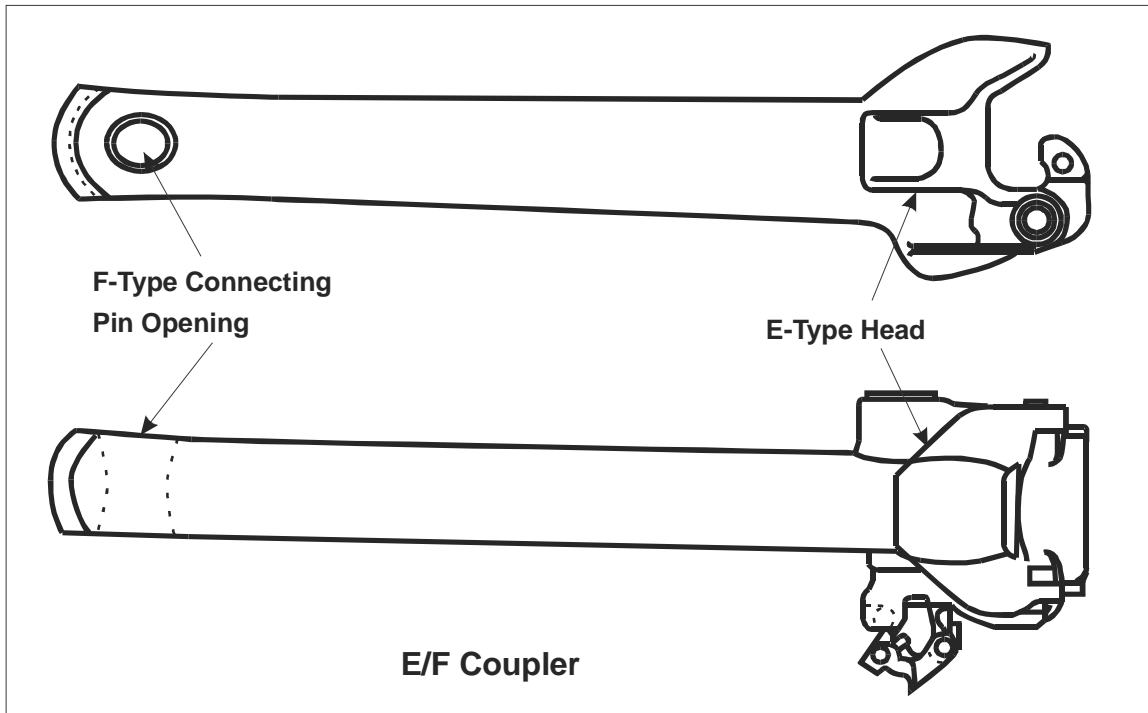

### B. Follower Block or Plate

The rectangular metal plate placed inside the coupler yoke at the front of the draft gear. It acts as a stop for the front of the draft gear in the pulling function. It transmits the stress of the draft gear force to the car center sill.

### C. Draft Gear:

This is the heart of the draft system. It is a large heavy component that absorbs the energy of the equipment coupling together and it also provides a rebound force that maintains slack between the cars. In this way the cars are moved without damage to other components or to the product within the cars. There are various types of draft gears designed for specific situations. The most common heavy capacity draft gear is the Mark 50. This type of draft gear is suited to heavy applications such as for coal cars, open top hopper cars and other bulk commodity cars. In this workbook hydraulic draft gears are covered. These are specifically designed for cars where the lading requires extra protection against impact. i.e. Bi-level automobile carriers.

Draft gears are interchangeable in accordance with AAR Rule 21. This is to ensure the correct capacity draft gear is applied to the car based on the car design requirements.



**Cardwell Westinghouse  
Mark 50 Draft Gear**

**D. Coupler Yoke**

The metal framework that houses the draft gear and the follow block or plate. It is connected or keyed to the shank of the coupler. There are two basic designs of yokes designed to fit the coupler application. The Y-40 yoke is typically used with E-type couplers and a horizontal cross key. The Y-45 Yoke is designed for use with the F-Type coupler. It uses a vertical pin to connect the yoke to the coupler.

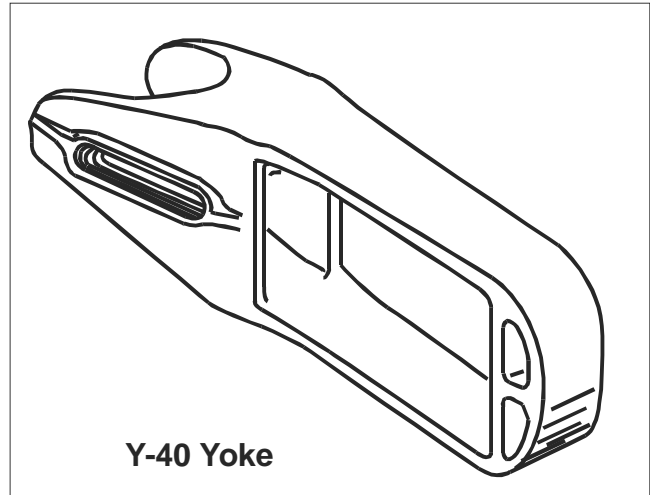

**Y-40 Yoke**

**E. Draft Gear Pocket**

The opening in the center sill of the car designed to house the draft assembly. When the draft gear and follow plate are installed in the yoke, the yoke is then inserted into the underside of the center sill at one end of the car. The draft gear and follower plate are allowed a specific size of pocket to allow restricted movement. The size of the draft gear pocket is restricted by the location of the front and rear lugs. The typical size of draft pocket for a Y-40 yoke and Mark 50 draft gear is 24<sup>5</sup>/<sub>8</sub>".

**F. Draft Gear Carrier or Carrier Iron**

To support the weight of the draft gear and associated components, a metal plate is secured to the underside of the center sill. It also allows free movement of the yoke as it moves in conjunction to the car movement.

**G. Draft Key or Cross Key**

The cross key (slang) is a large metal plate that is inserted through the slot in the coupler and yoke to tie the draft system to the coupler. The Draft/Cross Key is used with E-Type couplers and Y-40 yokes. On F-Type couplers and Y-45 Yokes, a large vertical pin is used to connect these parts.

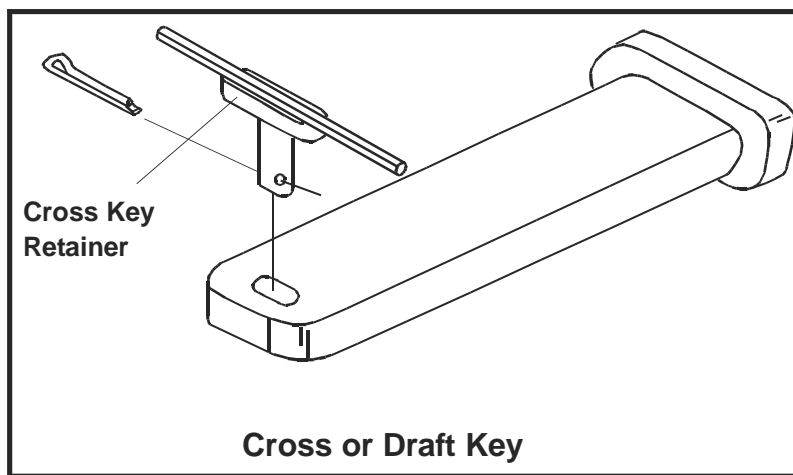

**Cross or Draft Key**

**H. Draft Key (Cross Key) Retainer**

The draft/cross key must be secured to prevent it coming out unintentionally. The securing mechanism used must have a positive locking mechanism. In this diagram it is a pin inserted in the hole of the draft key with a cotter key and a bar across the top of the pin. The bar is heated and bent to wrap around the draft/cross key.

### I. Draft Gear Lugs

The draft gear lugs or draft lugs can be broken down to the front and rear lugs. The rear lugs are secured to the center sill at the rear of the draft gear pocket. In some cases they may be part of the center plate spider casting. The front lugs are generally part of the striker casting.

### J. Striker Casting

The striker casting is a large metal casting secured to the inside end of the center sill. The casting has three main functions. First, the front lugs restrict the movement of the draft gear. It also acts as a support for the coupler shank. Third, it is the main component to absorb heavy impacts to the center sill. To do this, the striker casting is a heavy metal block that lines up with the horn of the coupler. When the car receives excessive pushing force exerted against it, the coupler will compress the draft gear. This allows the horn of the coupler to contact the face of the striker. If the gear becomes severely worn or receives too much impact it may become damaged. This is a warning of possible problems with the equipment.

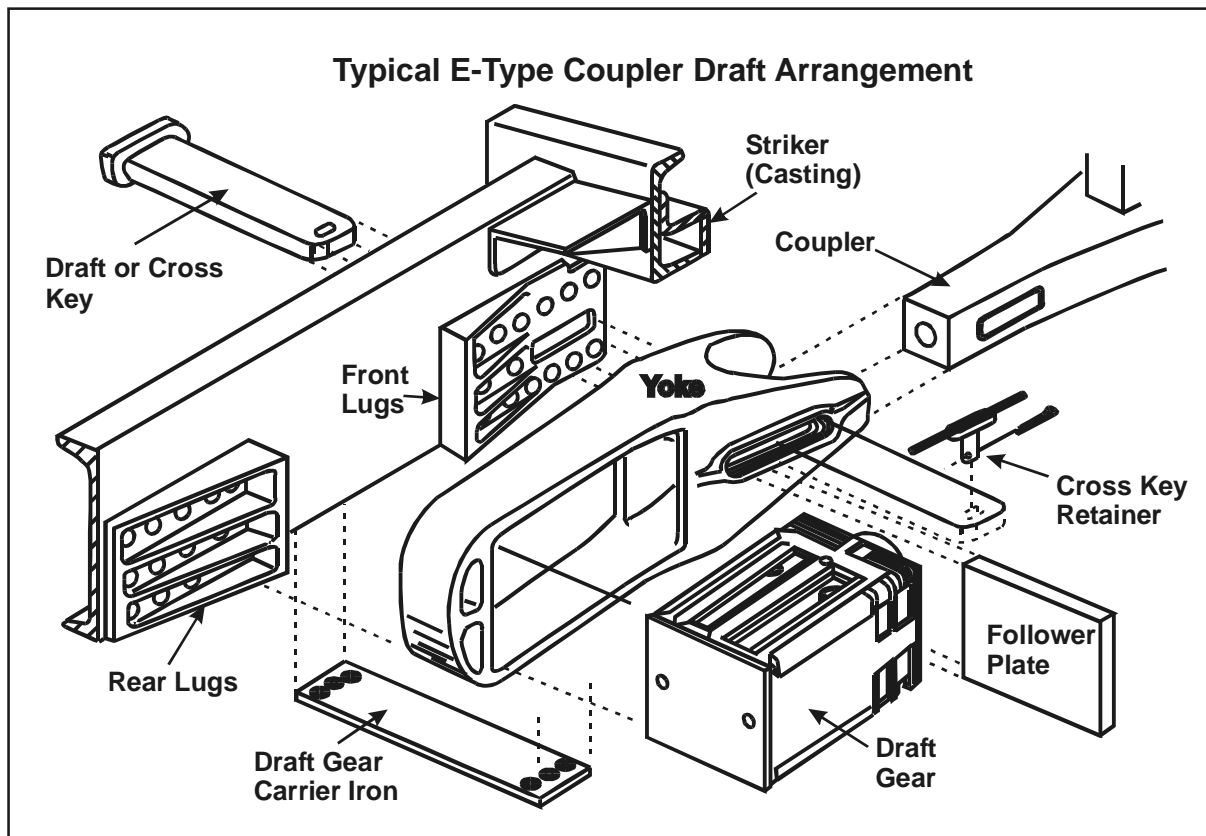

### Part 3: Overview of the Draft Gear Connection and Components

On page 6 is an exploded view of the typical components of an E-Type Coupler draft arrangement as they are designed to fit into the center sill of a freight car. The heart of the draft system is the draft gear. It is assembled in a fashion that it will cause it to be compressed in both directions, pushing and pulling. This will utilize the full operating effectiveness of the gear.

#### Pushing Position

In the draft or pushing position, the car or locomotive is moved by pushing on the coupler. Having slack between the cars and in the draft system allows for movement of the equipment without having to move the train as a solid block. In the diagram below you will see the pushing force on the front of the coupler will cause the end of the coupler shank to make contact with the follower plate. The follower plate makes contact with the front of the draft gear. At the opposite end of the draft gear are draft stops or lugs attached to the center sill. They form the rear end of the draft pocket. With the follower plate forcing the front of the draft gear back, the rear of the draft gear cannot move any farther back because of the lugs. The result is the internal components of the draft gear are compressed to act as a shock absorber to the pushing movement. This is a typical E-Type Coupler arrangement. For other types of coupler and draft systems, the basic function remains the same. The only difference is the type and capacity of the draft gear.

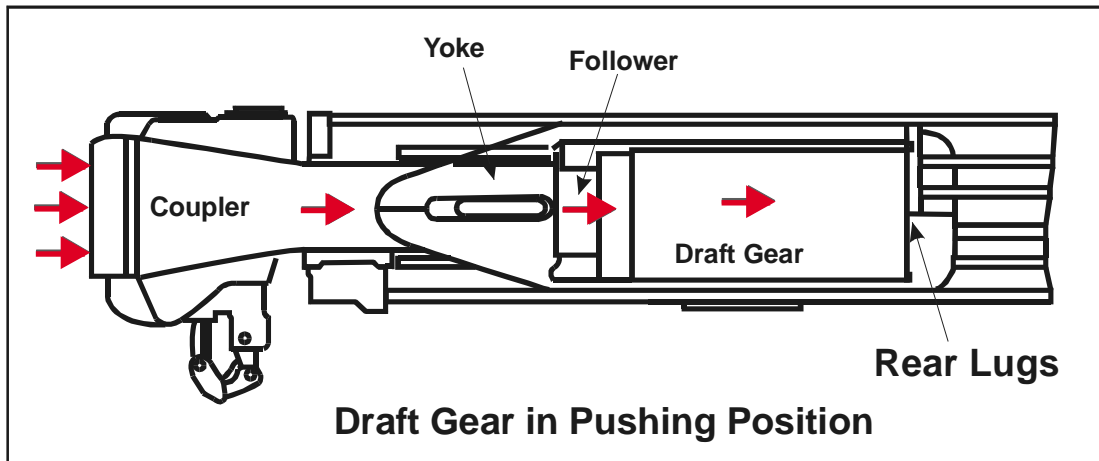



## Pulling Position

When moving a group of cars or a train each car is pulled by the coupler and the internal operation of the draft arrangement must work to allow the draft gear to work like a shock absorbers. The coupler is connected to the yoke by a cross or draft key. When the coupler is pulled forward, the draft key pulls the yoke forward. Inside the yoke is the draft gear and follower plate. With the yoke pulling the draft gear forward from the back end, the draft gear movement is restricted by contact the follower plate. The follower plate move forward slightly but is now restricted by the front draft lugs. The result is the draft gear now gets compressed again. Thus the draft gear is compressed in both the pushing and pulling action of the coupler.

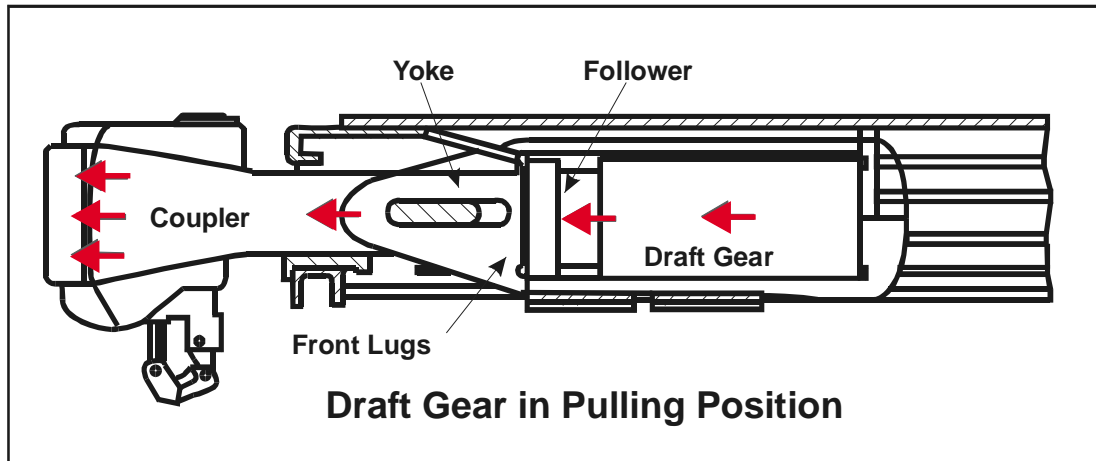

The amount of movement of the draft arrangement must be controlled. If there is too much slack between the draft gear/follower plate and the pocket, the result is excessive forces inside the center sill of the car. This can translate to bulging on the side of the center sill. Although this can also be caused by broken internal components. During an inspection process of the draft arrangement, the inspector should be looking for certain items that may indicate the condition of the draft components. For example;

1. The space between the coupler horn (standard E-Type) and the striker in a relaxed position is approximately 4". If there is excessive space between the coupler horn and striker it may indicate the front lugs may be damaged, the draft gear may be damaged or the yoke may be broken. Check underneath the center sill paying close attention to the back end of the yoke and gear. If the distance between the coupler horn and striker is too close in the relaxed position it may indicate the same things but the car may have been pushed into this position.
2. Marks on the coupler such as a highly polished area or the space where the coupler horn makes contact may be cracked or broken. This may indicate the draft gear or associated components may be damaged or are starting to wear out. Wear limitations of the draft gear must be in accordance to AAR Interchange Rule 21.
3. The height above the rail for the coupler is set to ensure the cars couple together properly and allow a maximum amount of contact between the couplers for both pulling and pushing actions. Required coupler heights must be within AAR Rule 16, Item E, 12.

Empty Cars	Min. 32 <sup>1</sup> / <sub>2</sub> "	Max. 34 <sup>1</sup> / <sub>2</sub> "
Loaded Cars	Min. 31 <sup>1</sup> / <sub>2</sub> "	Max. 33 <sup>1</sup> / <sub>2</sub> "

This measurement is taken from the top of rail to center face of the coupler knuckle. Where possible adjustments should be made when car is empty.

These measurements can only be checked properly when the cars are not connected. However, on an inspection if the couplers do not match evenly it may indicated the is a problem with the coupler carrier iron.

## Part 4: End of Car Cushioning and Cushion Underframes

### A. End-of-Car Cushioning

End of car cushioning units are similar in operation to standard draft arrangements. In both cases the draft arrangement must work like shock absorbers for the car. End-of-car equipment is generally used with cars carrying products that are susceptible to damage if the car was subjected to heavy shunting action. Items such as automobiles, boats, electronic equipment require a softer draft arrangement than cars carrying coal, potash or other bulk commodities. To provide a softer contact for goods that are susceptible to damage the car usually has a long shank coupler and a hydraulic or pneumatic type of draft gear. This type of draft arrangement allows for longer travel of the coupler and draft system to provide a softer, smoother buffing and pulling on the car.

### B. Cushioned Underframe

The cushioned underframe design generally implements the use of the center sill of the car with the draft system to control the push and pulling forces exerted on the coupler. In the example below you will note the draft arrangement is in the center of the car. There is an internal center sill that is allowed to move within the normal center sill. Its movement is controlled by the return spring and the low pressure hydraulic cylinder. This type of car is also designed for commodities that are susceptible to damage. Note with cushioned underframes and end-of-car cushioning the car has a flexible trainline that must be free to move under the end of the car.

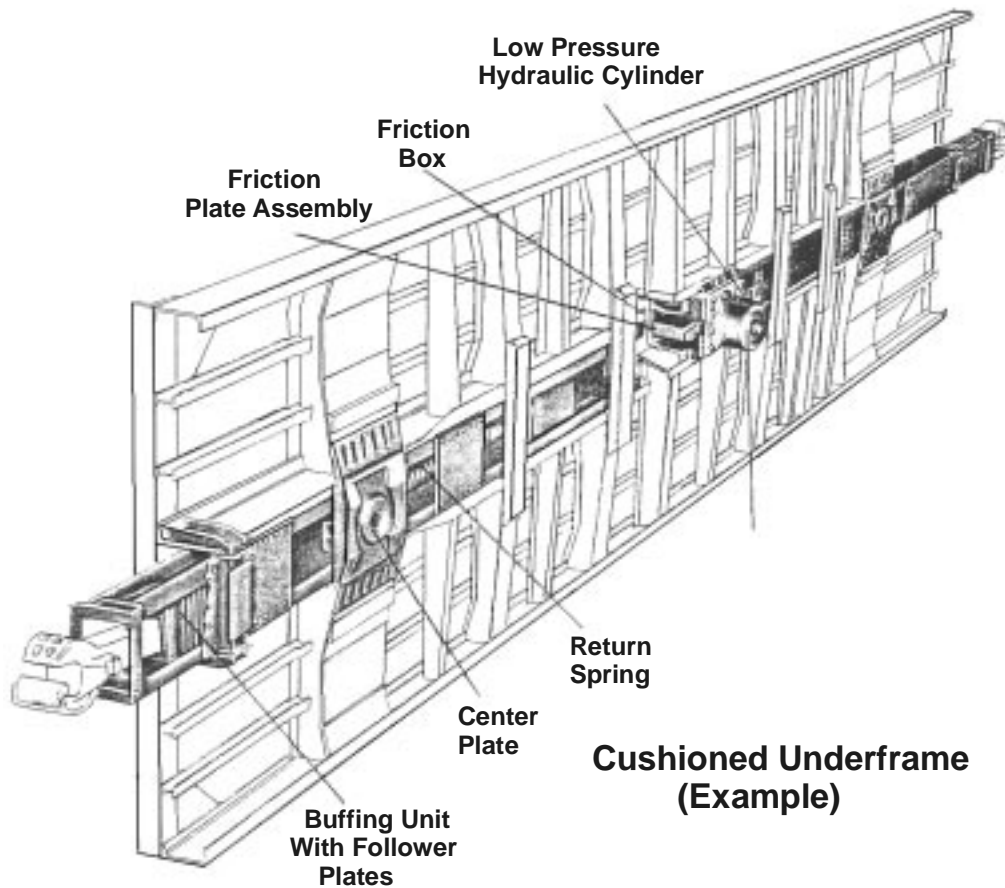

## Part 5: Internal Operation of a Draft Gear

The design of a draft gear is important for the proper buffeting and pulling operation on the car. The draft gear not only returns the coupler after each connection but more importantly it provides cushioning to prevent damage to the car and lading. Matching the draft gear to the type of car and its specific use is important to provide the correct cushioning effect on the car.

Draft gears typically use a system of springs and wedges to absorb and nullify the force exerted on them. The initial impact from the follower plate is directed through a series of wedges to the springs inside the gear housing. The wedges are geometrically arranged to absorb the coupler force and slow down the reaction to this force in much the same fashion a shock absorber is used in an automobile. The springs provide an initial resistance to the heavy follower plate contact from the coupler and also lengthen the friction pack to fill out the pocket.

### Cardwell Westinghouse Draft Gears

#### 1. Mark 325

The Mark 325 Draft gear is specially designed to provide high capacity, all-steel performance in a streamlined package. It's the lightest Mark series draft gear available and does not compromise performance. It is AAR rated at 47,327 ft. pounds. This makes it the highest capacity all steel draft gear available. Used for both unit train and general service. The Mark 325 is used extensively with intermodal traffic cars.

It is designed with 3<sup>1</sup>/<sub>4</sub>" travel to fit all new cars. It fits into Group J in AAR Rule 21 for all types of service. The Mark 325 can be easily reconditioned and returned to service time and time again.

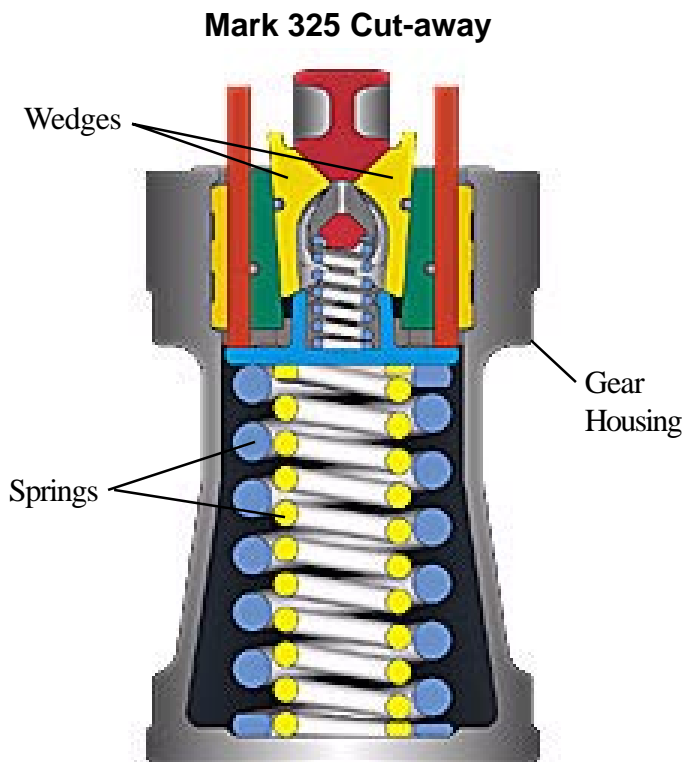

## 2. Mark 50 and Mark 500

The Mark 50 and Mark R-500 are the standard gear for unit train service. As you can see in the diagram below the Mark 50 is a heavy duty gear designed for long life under severe operating conditions. It is similar in design to the Mark 325 in the use of wedges and springs.

The Mark R-500 uses a solid rubber tube inside the springs housing assembly as shown below.

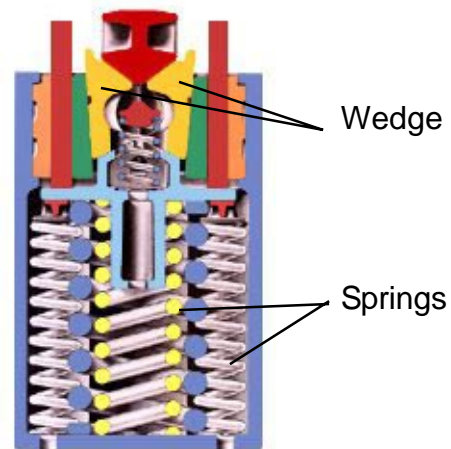

**Mark 50**

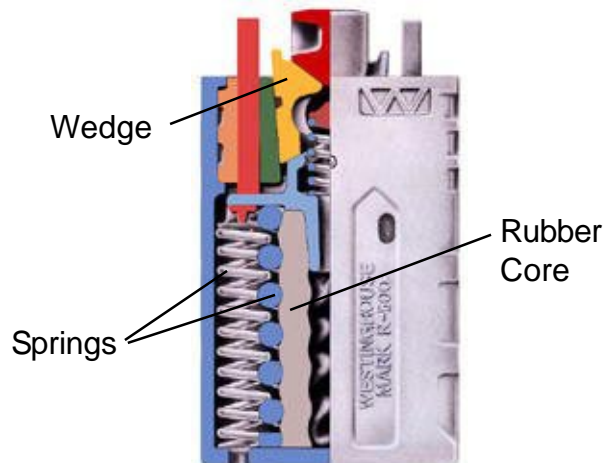

**Mark 500**

### 3. Mark H-60

The Mark H-60 features a unique hydraulic unit working in parallel with the proven helical spring group. This combination actuates the friction clutch. The result is increased cushioning capacity for 24<sup>5</sup>/<sub>8</sub>" pocket draft gears which means more protection for the car.

The hydraulic seals are static and are purposely located on the downstream low pressure side to provide long life. Although the Mark H-60 is specifically designed for intermodal cars, it can be used on all railcars having a standard 24<sup>5</sup>/<sub>8</sub>" pocket. In the drawing below you will notice the hydraulic unit in the center of the gear housing.

Flat Car) intermodal freight equipment. They replace the use of a standard coupler and draft system. Through the use of an articulated connector four coupler and draft assemblies and four truck assemblies are eliminated reducing unnecessary weight.

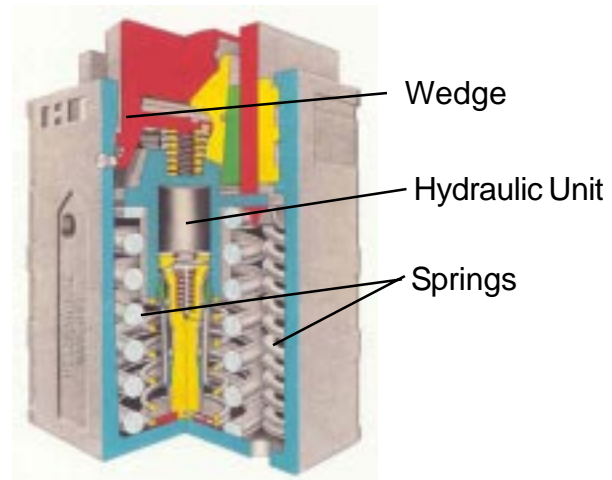

**Mark H-60**

## Part 6: Articulated Connectors

Cars equipped with articulated connectors are typically multiple unit TOFC/COFC (Trailer on Flat Car/Container or Container on Flat Car) cars. They have a conventional type draft assembly on the end of the multi unit car, but in between the well or flat units they are connected with a special type of assembly called an articulated connector. The articulated connectors save weight, parts and equipment. On standard freight cars, each car has its own draft assembly at each end. They also have a complete truck assembly at each end including truck bolsters, side frames and wheels. On multi unit cars set up with articulated connectors, there is one truck assembly between each two flat units or well units. This cuts down on the number of truck assemblies required. To make a connection between the cars the articulated connector is mounted fit into the center plate of the truck bolster. There are three types of articulated connectors.

### A. Cardwell Westinghouse SAC-1 Connector

The SAC-1 uses a spherical ball assembly that rotates within a smooth race unit. This provides for movement when the car flexes for cornering and track fluctuations. Connected to the center sill on one flat car unit is the female component and on the other car is the male counterpoint connector, which is the actual ball connector. When the units are coupled together the SAC-1 becomes the draft system of the two flats. The bottom of the articulated connector is the male center plate. This unit fits into the female center plate of the truck assembly. In the first diagram is a drawing of the complete connection joining the two cars.

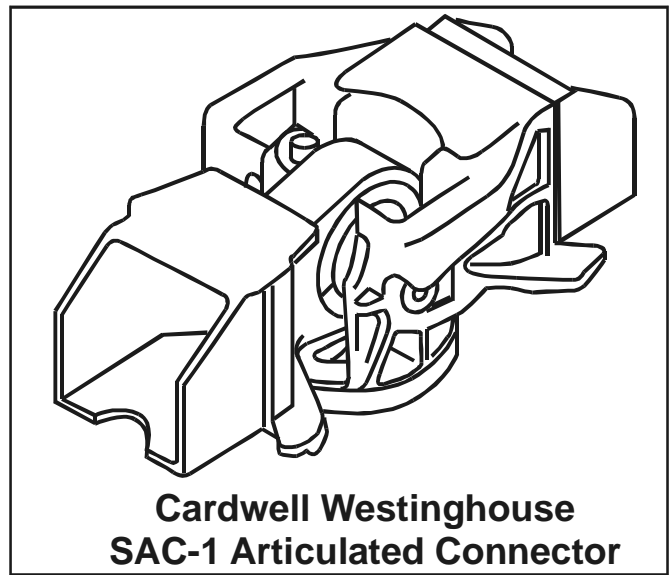

On the second diagram is the male and female connections separated. The male ball connector has an extension on each side of the ball. These extensions hold the ball in the female connector with the use of the locking wedges. The locking wedges are held in position by the bolts, washers and nuts shown.

To separate the male and female connections, the locking wedges must be removed. **DO NOT** apply heat to any area of the ball connector to remove this unit. This could seriously affect the race of the ball connector.

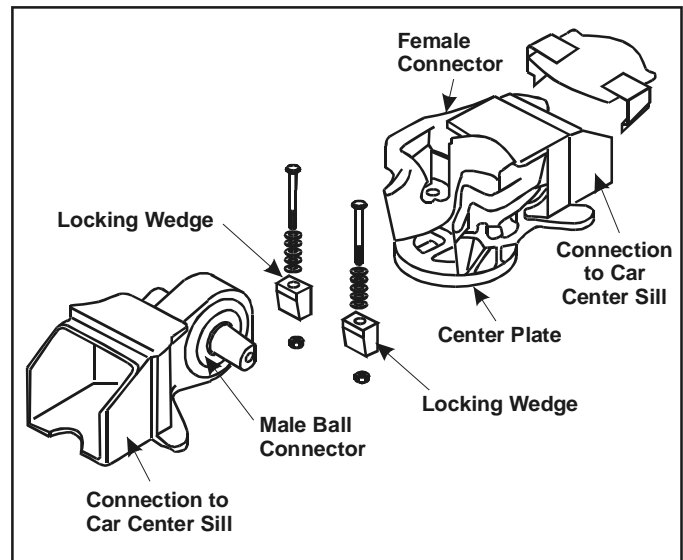

## Coupling Procedure

1. Rotate the pin of the male coupling (1) until the two flat pin surfaces are 10 degrees (nominal) off of vertical and are facing toward the female coupling (2).
2. Lower the male coupling down into the female coupling (2) until the two horizontal pins of the male coupling (1) seat into the pin pockets of the female coupling (2).

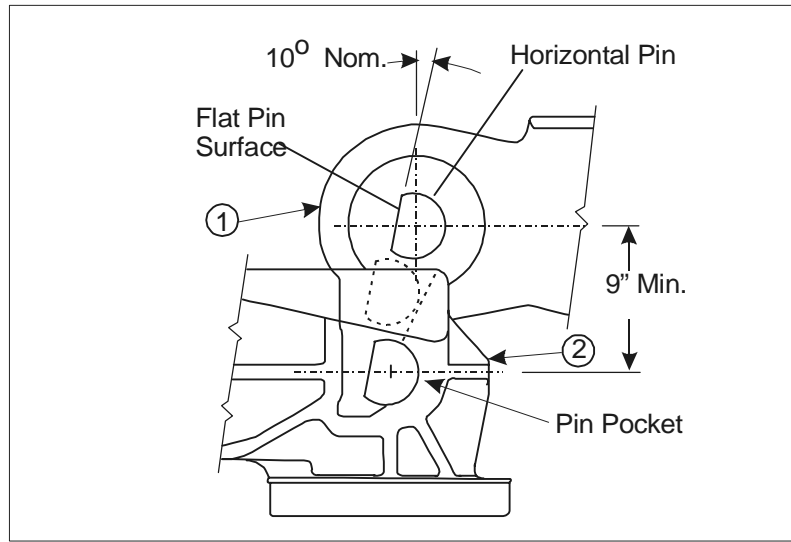

3. Install the two locking wedges (3) between the two flat pin surfaces of the male coupling (1) and the vertical machined surfaces of the female coupling (3). Match the vertical 90 degree surface of the locking wedge (3) with the 90 degree vertical machined surface of the female coupling (2), making sure to align the vertical hole in the locking wedge (3) with the drilled hole in the female coupling (2).

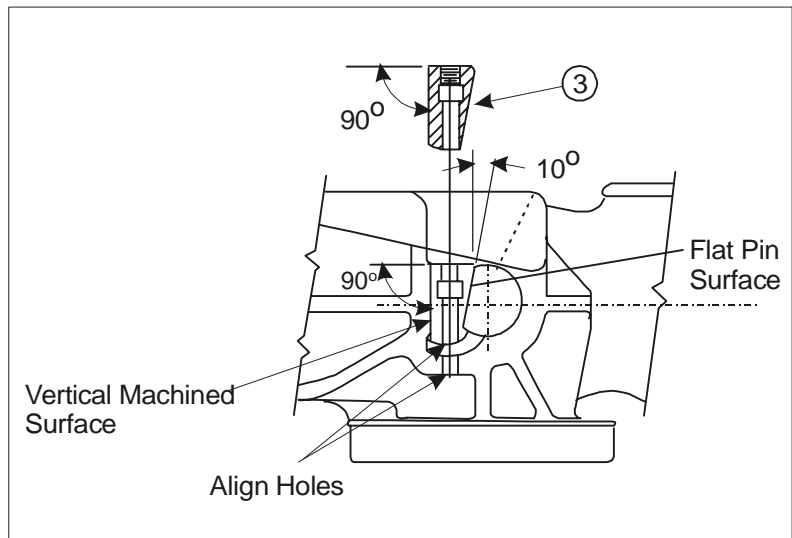

4. Stack five Belleville springs (7) over the 1" diameter (Grade 5 or 8) bolt (8) and insert into the hole in the locking wedge (3). (Note: The Belleville springs must be staked with opposite sides touching as shown in Figure 4.) Install washer (9) and nut (6) and torque to 550 to 650 ft. lbs. (Note: Belleville springs (7) should be flat after torquing.) Repeat same procedure for the other locking wedge.

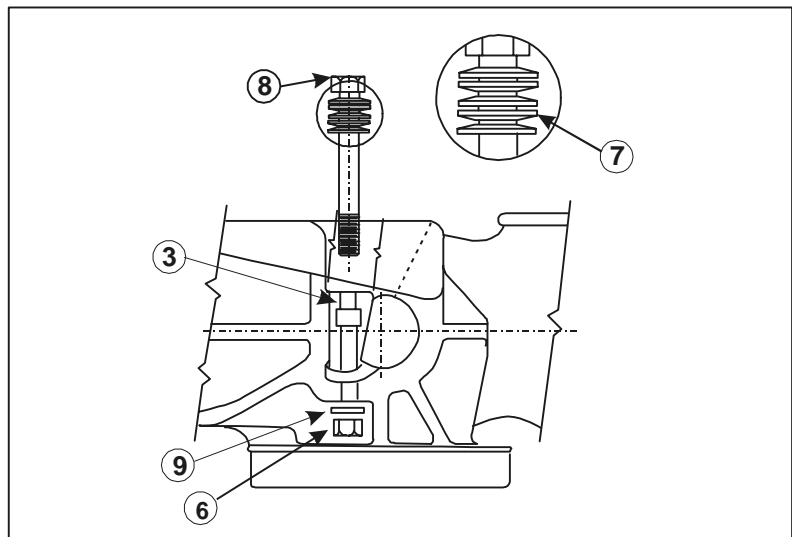

- Using a  $\frac{3}{8}$ " bar, install shroud (5) over female coupling making sure clips on either side go all the way down and snap into place over the support arms of the female coupling (2).

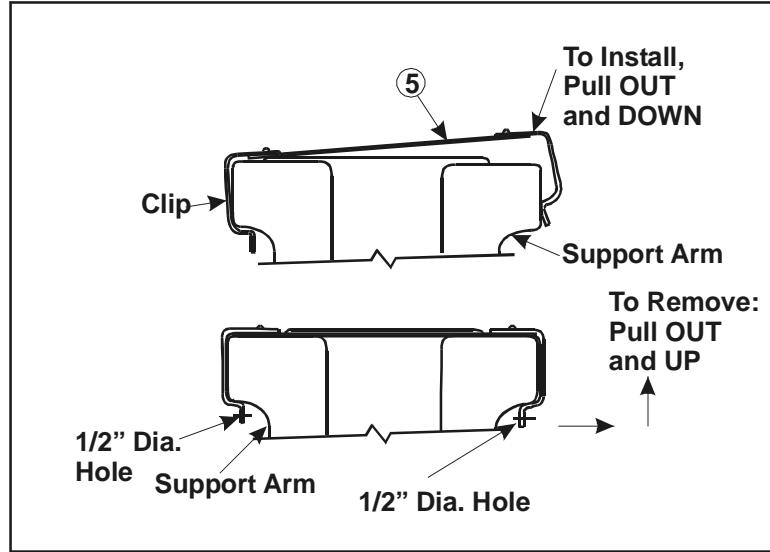

### Uncoupling Procedure

- Remove shroud (5) by inserting a  $\frac{3}{8}$ " bar in the  $\frac{1}{2}$ " hole and moving clip back away from support arm.
- Remove the nut (6) and washer (9), 1" bolt (8) and Belleville springs (7).

#### Option A:

Lay wedge shoe removal tool across arms of female coupling (2) making sure that the safety strap extends under arm of female coupling (2). Insert  $1\frac{1}{4}$ " 7UNC (Grade 5 or 8) bolt into thrust bearing and then into the hole in the wedge shoe removal tool which is directly over the hole in the locking wedge (3). Thread  $1\frac{1}{4}$ " bolt into locking wedge (3). Continue to turn bolt (clockwise), using an air wrench which generates a minimum of 1,100 ft. lbs. torque, until locking wedge (3) becomes dislodged.

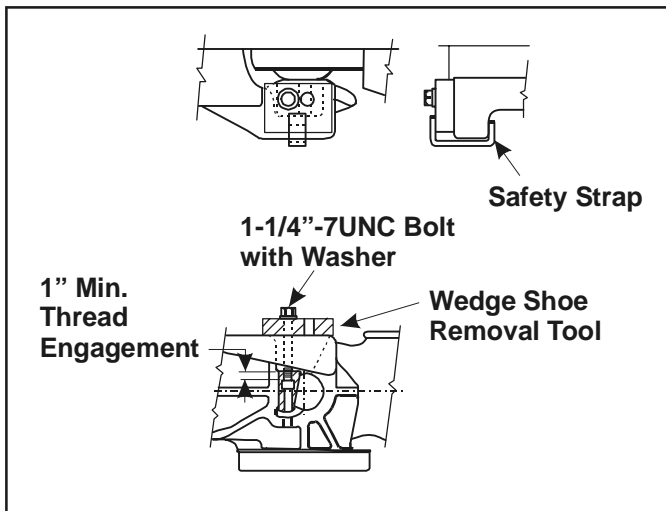

**WARNING:** *Extreme caution must be used when removing wedge, as it can become dislodged and eject at any time.*

Repeat same procedure for other locking wedge. If wedge cannot be removed, see Option C.



**Option B**

Lay wedge shoe removal tool across arms of female coupling (2) making sure that the safety strap extends under arm of female coupling (2). Set 50 ton ‘center hole’ hydraulic ram over the hole that is directly over the hole in the locking wedge (3). Insert 1 1/4” 7UNC (Grade 5 or 8) bolt with washer through center of ram, through wedge shoe removal tool and thread into locking wedge (3) to obtain 1” minimum thread engagement. Install hand pump to ram. Begin pumping and continue until the locking wedge (3) becomes dislodged.

**WARNING: Extreme caution must be used when removing wedge, as it can become dislodged and eject at any time.**

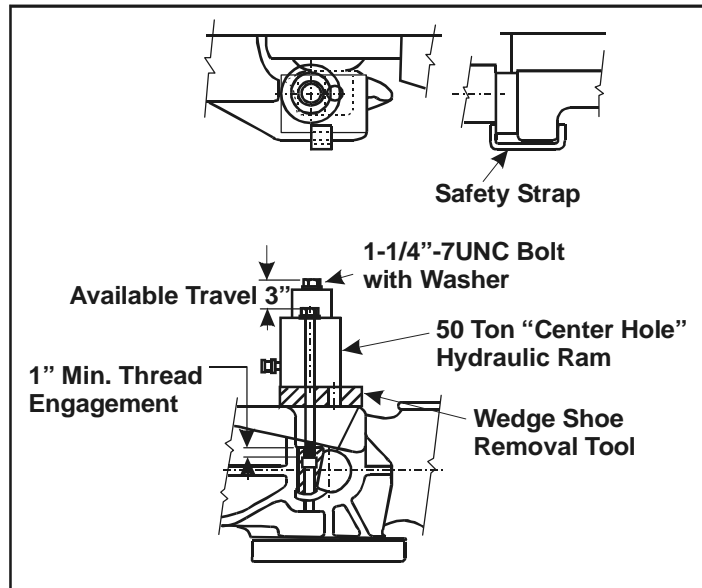

Repeat same procedure for other locking wedge. If wedge cannot be removed, see Option C.

**Option C**

**IMPORTANT:** Place a flame retardant material between the spherical ball in the male coupling (1) and the locking wedge (3) to protect the spherical ball’s surface from slag splatter. Using a minimal amount of flame, carefully torch-cut vertically from the hole in the locking wedge (3) to the edge. Repeat for the other side of the locking wedge (3) and remove.

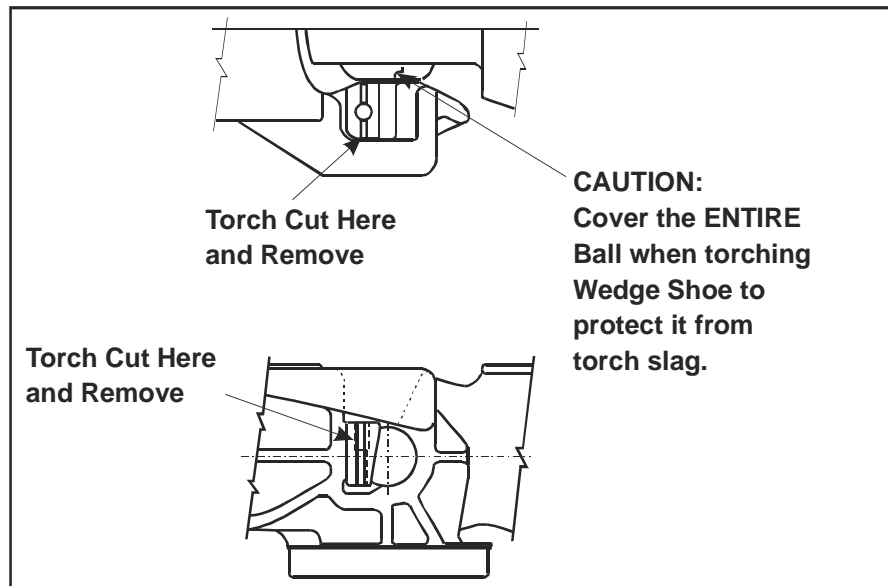

4. Move the cars together until the two horizontal pins on the male coupling (1) clear the female coupling (2). Safely secure the cars and move them away from each other. Place in a proper safe position.

**B. ASF Articulated Connectors**

The ASF connector is used in the same way as the SAC-1 however, the components are slightly different. The ASF connector shown in the picture to the right is connected as it would be applied to the flat cars. The lower picture shows the three main components. It has a female connector, male connector and a connecting pin. Once the male connector is inserted into the body of the female connector the pin is inserted into the top through the hole.

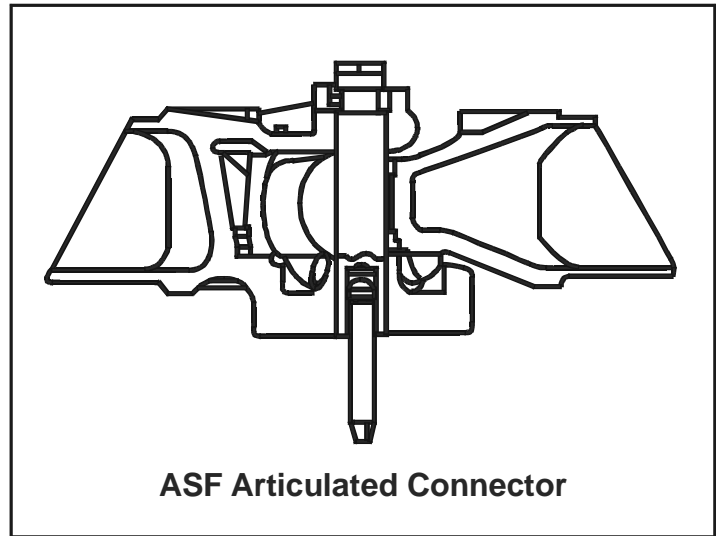

An important feature of the ASF connector is to make sure the wedge is all the way to the top before inserting the male connector. The wedge is held in place with a 1/2" rod, temporarily inserted into an opening in the casting on either side. Once the unit is connected remove the rod.

To remove the connecting pin, the wedge must be moved and held at the top of the casting. If it is not moved to the top inside the casting, the connecting pin will not move freely to be removed from the connection.

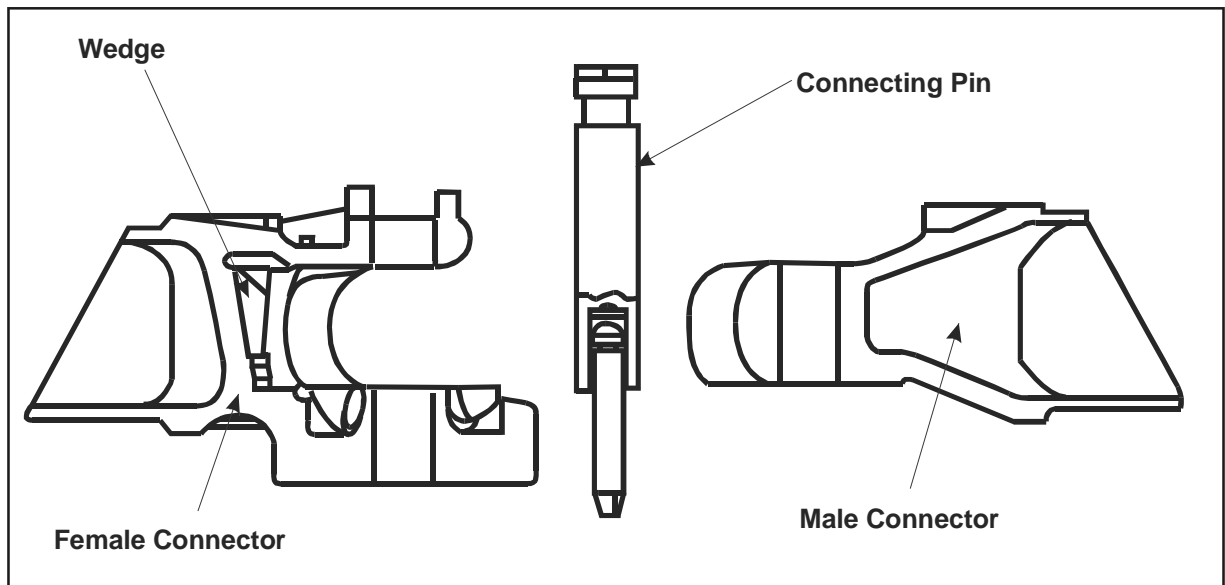

### C. National Articulated Connector

The National Connector is similar in design to the ASF Connector with a couple of exceptions. The connecting pin is slightly larger and the male component is equipped with a rubber bushing. The rubber bushing surrounds the connecting pin to allow movement and still hold the unit together. The connecting pin is secured in place with a bolt across the hole on the top (not shown).

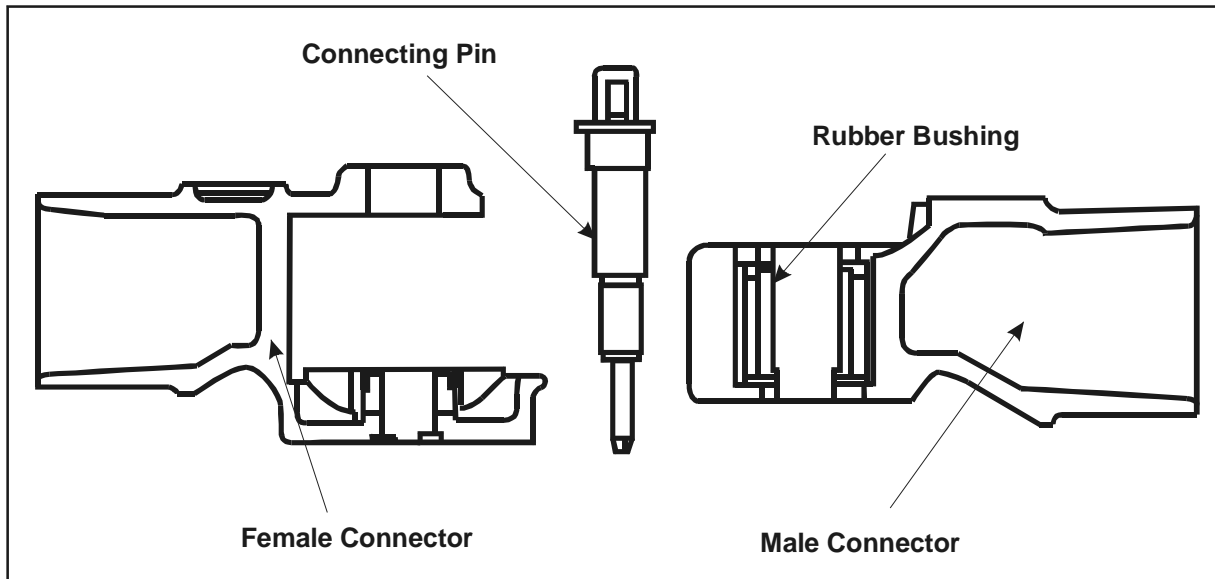
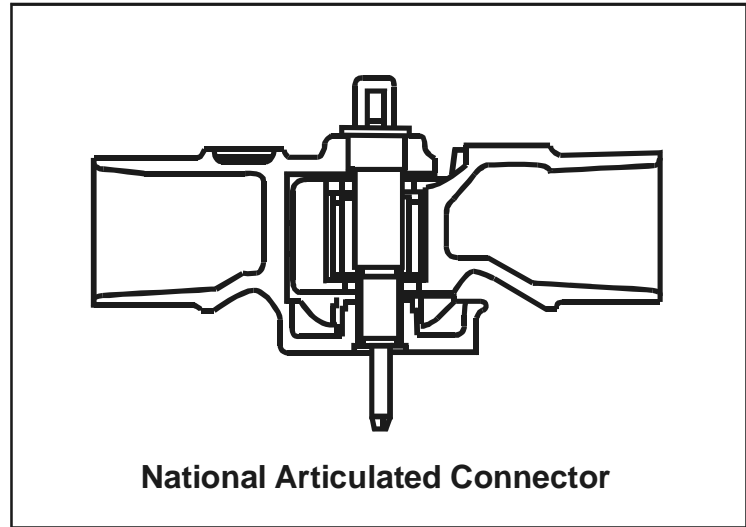

---

**Review Exercise**

1. The draft gear and follower block are placed inside the pocket of the \_\_\_\_\_.
2. The draft gear is compressed in the:
  - a. Pulling function
  - b. Pushing function
  - c. a and b
  - d. None of the above
3. To connect an E-Type coupler to the yoke a \_\_\_\_\_ is used to ensure the draft gear operates properly.
4. Standard coupler heights above the top of the rail per AAR Rule 16 are:

Empty Car	Min. _____	Max. _____
Loaded Car	Min. _____	Max. _____
5. On a SAC-1 articulated connector, what are the wedges used for?  
\_\_\_\_\_
6. On an ASF articulated connector, what must be done to ensure the connection pin can be inserted or removed properly?  
\_\_\_\_\_

***Review Exercise - Answers***

1. The draft gear and follower block are placed inside the pocket of the **Yoke**
2. The draft gear is compressed in the:
  - a. Pulling function
  - b. Pushing function
  - c. a and b***
  - d. None of the above
4. Standard coupler heights above the top of the rail per AAR Rule 16 are:

Empty Car	Min. <b>32 1/2"</b>	Max. <b>34 1/2"</b>
Loaded Car	Min. <b>31 1/2"</b>	Max. <b>33 1/2"</b>
5. On a SAC-1 articulated connector, what are the wedges used for?  
***Secure the ball connector in place***
6. On an ASF articulated connector, what must be done to ensure the connection pin can be inserted or removed properly?  
***The wedge must be all the way to the top***