

Actual size 4.75 x 7.75

OPERATING MANUAL

TP-401

FOR

Model RS-3 Road Switcher

This manual covers basic operating instructions to assist the engineman in the efficient handling of the 1600 HP model RS-3 road switching locomotive.

Descriptive information pertaining to the most commonly used "specialties" is contained herein and defined with the phrase (if used). The manual is written so as to be complete for locomotives with or without the specialty equipment.

The information furnished is based on construction as of date material was compiled.

AMERICAN LOCOMOTIVE COMPANY
GENERAL ELECTRIC COMPANY
Schenectady, N. Y.

Printed in U. S. A.

July 1950

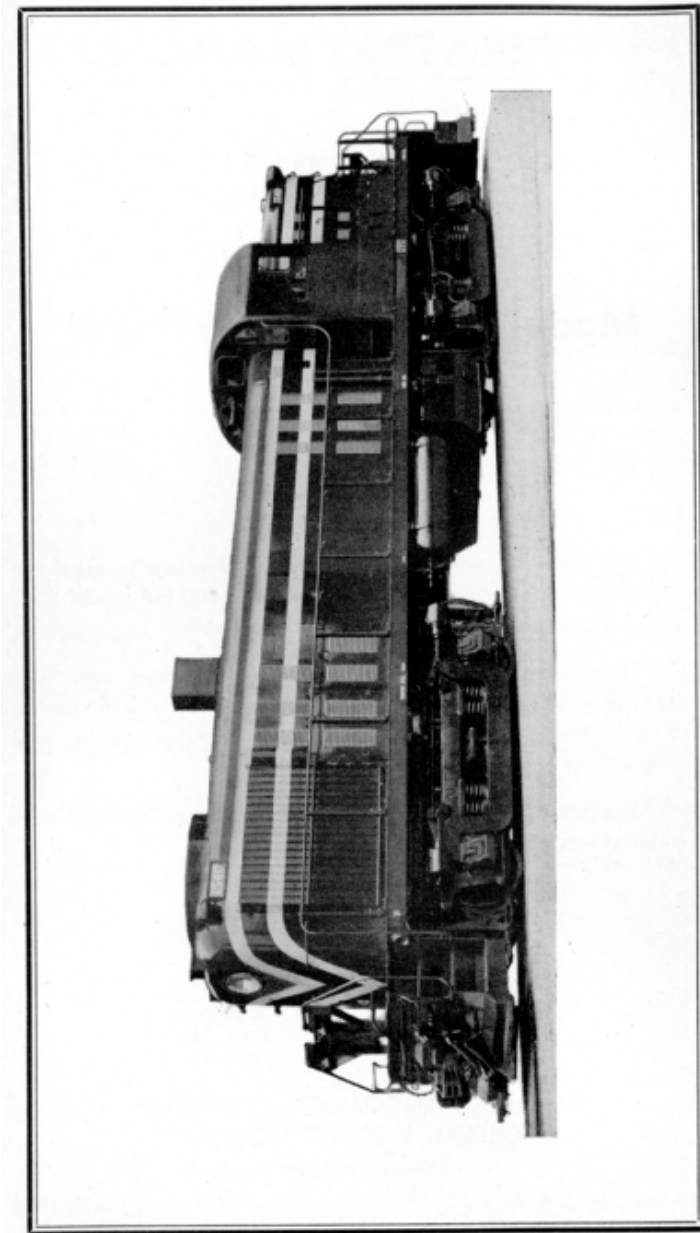
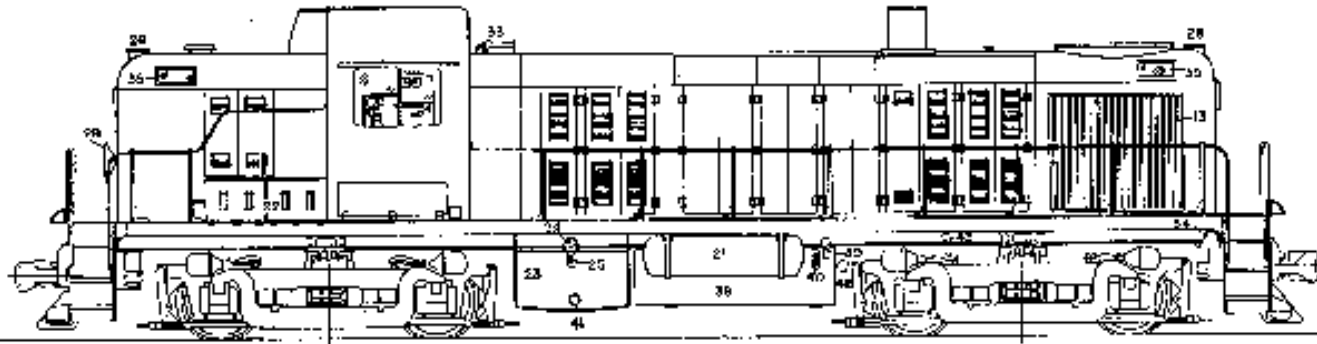
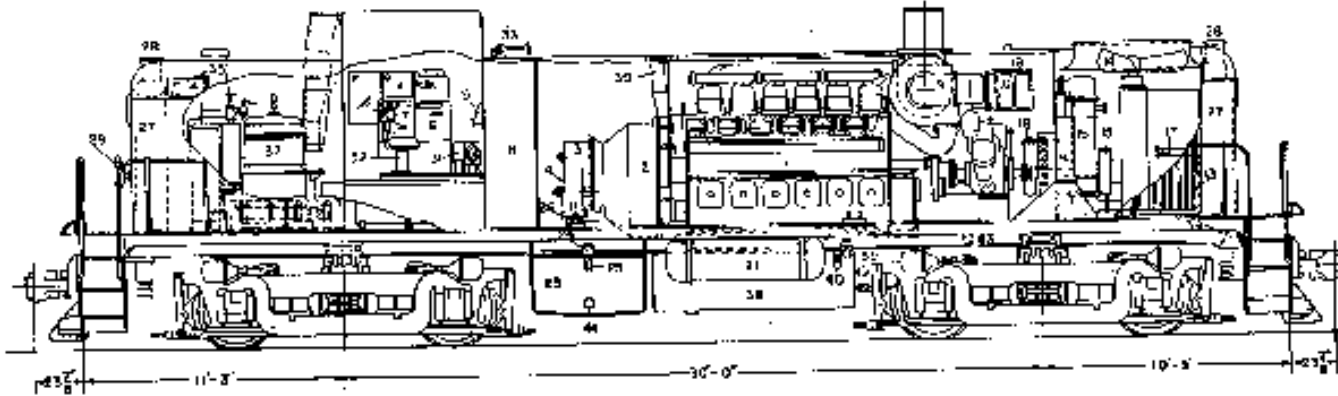
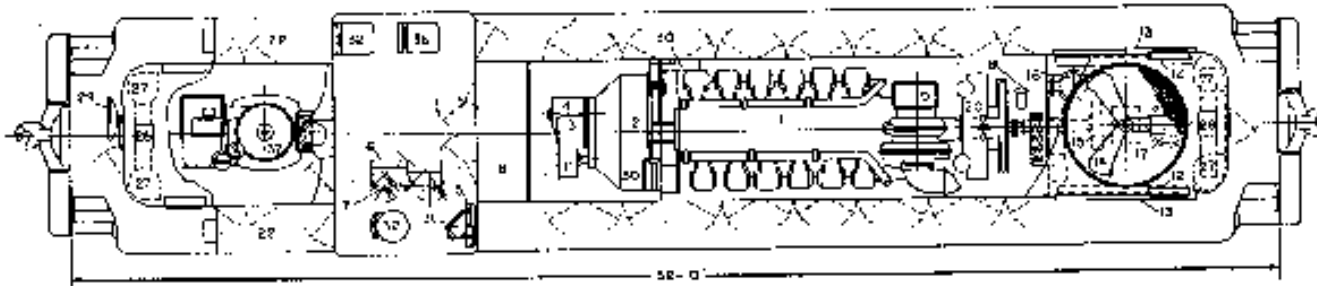

TABLE OF CONTENTS

General Data	Section I
Introduction.	Section II
Controller Operating Handles	Section III
Preparing for Operation	Section IV
Operating Procedure	Section V
Air Equipment	Section VI
Miscellaneous Operating Instructions	Section VII
Gauges and Instruments	Section VIII
Automatic Alarms and Safeguards	Section IX
Accessories	Section X



- | | | | |
|--|-----------------------------|----------------------------------|--|
| 1- ENGINE | II-TRACTION MOTOR BLOWERS | 22- BATTERIES | 33- HORN |
| 2- MAIN GENERATOR | 12- RADIATORS | 23- FUEL TANK | 34- BELL |
| 3- EXCITER | 13-RADIATOR SHUTTERS | 24- FUEL TANK FILLING CONNECTION | 35- NUMBER BOXES |
| 4- AUXILIARY GENERATOR | 14-RADIATOR FAN | 25- FUEL TANK GAUGE | 36- CAB SEAT (MOD.) |
| 5- GAUGE PANEL | 15- RADIATOR FAN CLUTCH | 26- EMERGENCY FUEL CUT OFF | 37- STEAM GENERATOR (MOD.) |
| 6- CONTROL STAND | 16-LUBRICATING OIL COOLER | 27- SANDBOXES | 38- WATER TANK (MOD.) |
| 7- BRAKE VALVES | 17- LUBRICATING OIL FILTERS | 28- SAND BOX COVER | 39- WATER TANK FILLING CONNECTION (MOD.) |
| 8- CONTROL COMPARTMENT | 18-LUBRICATING OIL STRAINER | 29- HAND BRAKE | 40- WATER TANK GAUGE (MOD.) |
| 9- TURBO SUPERCHARGER | 19- ENGINE WATER TANK | 30- GENERATOR AIR DUCTS | 41- FUEL TANK DRAIN |
| 10-TURBO SUPERCHARGER
FILTERS & SILENCERS | 20-AIR COMPRESSOR | 31- CAB HEATER | 42- ENGINE OIL DRAIN |
| | 21-MAIN AIR RESERVOIR | 32- CAB SEATS | 43- ENGINE WATER FILL |

I GENERAL DATA

Model Number	RS-3
Class – AAR	B-B
Rated Engine Speed	1000 RPM
Engine Horsepower	1600 HP
Bore	9 Inch.
Stroke	10-1/2 Inch.
Fuel Oil Tank Capacity	800 Gal.
Lubricating Oil Capacity	200 Gal.
Cooling Water Capacity	250 Gal.
Governor Oil System Capacity	4 Qt.
Sand Capacity	8 Cu. Ft.
Steam Generator Water Tank Capacity (If Used)	800 Gal.
Wheel Diameter	40 Inch.
Journal Size	6-1/2" X 12"
Height (Maximum)	14' - 5-1/8"
Width (Maximum)	10' - 1-7/8"
Length (Inside Knuckles)	55' - 11-3/4"
Track Curvature-With Train	21°
Locomotive Alone (Min. Radius)	150 Ft.
Weight-On Drivers.	240,000 Lbs.
Total Locomotive	240,000 Lbs.

II INTRODUCTION

The 1600 HP Road Switcher is a single unit locomotive designed for freight, passenger and switching service. Controls may be applied for multiple unit operation of two, three or four units controlled from one cab.

1. DIESEL ENGINE

The locomotive is powered by a 12 cylinder, V type 9" X 10-1/2", single acting, turbosupercharged, 1600 HP ALCO-GE Diesel engine of four stroke cycle having an open combustion chamber with solid fuel injection. The engine speed is 350 RPM idle to 1000 RPM full speed and governed by an electro-hydraulic governor.

Each cylinder requires two engine revolutions or four strokes of the piston to complete one working cycle. One complete piston working cycle is as follows: first, air is blown into the cylinder on the down or intake stroke; then on the compression stroke; this air is compressed by the rising piston with a large increase in air temperature. Just before the end of the compression stroke, fuel is injected into the cylinder where it is ignited by the heat of the compressed air. The resulting combustion increases the cylinder pressure and on the third or power stroke, this gas pressure forces the piston down. On the fourth or exhaust stroke, the burnt gases are expelled by the piston traveling upwards and by scavenging action of the inlet air made possible by a large intake and exhaust valve overlap.

The Diesel engine has an all welded steel frame. Full pressure lubrication of all parts is provided. A closed cooling system is used; the cooling water flows successively through the engine, the radiators and the lubricating oil cooler and is circulated by an engine driven centrifugal pump. Lubricating oil is cooled by the water in the heat exchanger and the water by fan cooled radiators. Thermostatically controlled radiator shutters and fan maintain desired engine temperature automatically.

2. TRACTION AND AUXILIARY GENERATORS

The traction generator is direct-connected to the Diesel engine crankshaft while the auxiliary generator, amplitudvneexciter and rear traction motor blower are gear driven from the generator shaft. The traction generator produces direct current for operation of the traction motors and the amplitudyne exciter furnishes excitation for the traction generator. The rear

The rear blower furnishes ventilating air for the traction motors on the rear truck. The front truck blower which is belt driven from the fan drive shaft, furnishes ventilating air for the motors on the front truck. The auxiliary generator furnishes current for battery 'charging and low voltage circuits for lighting, control, fuel pump and excitation.

3. TRACTION MOTORS

Four traction motors are used on a locomotive unit. Each motor is supported by axle suspension bearings and a spring nest mounted on the truck bolster.

Shrunk onto the motor armature shaft is a pinion which meshes with a drive gear pressed onto the wheel axle. The gear ratio between the pinion and drive gear determines the maximum locomotive speed and is expressed in two figures such as "74/18". The first number indicates the number of teeth on the driven gear and the second number indicates the number of teeth on the pinion.

The traction motors are connected either in series-parallel or parallel depending upon the speed of the locomotive. During acceleration the selector handle movement controls the following motor connections:

No. 1	Series-Parallel
No. 2	Series-Parallel Shunted Fields
No. 3	Parallel
No. 4	Parallel Shunted Fields

The motor connections take place in reverse order when a train is decelerating with power on.

"Transition" is the changing of traction motor connections and is controlled by the movement of the selector handle. Two methods of transition are in use, manual or automatic.

The forward and reverse movement of the locomotive is controlled by the positioning of the reverser which, when moved from forward to reverse position by the reverse handle at the engineer's position, changes the direction of the current through the traction motor fields.

4. AUXILIARY EQUIPMENT

On road switching locomotives, the Diesel engine drives the radiator fan through an eddy current clutch and the air compressor through a flexible coupling.

5. DYNAMIC BRAKING (If Used)

The dynamic brake is a means by which the traction motors are used to produce braking instead of pulling effort. The motors are reconnected as generators and the power produced by them is dissipated as heat by a fan blown resistor. This brake is used principally on grades, though it may be used to very good advantage for slowdowns. The resistor assembly is mounted in the top of the steam generator compartment.

III CONTROLLER OPERATING HANDLES

A. THROTTLE HANDLE

1. Has an IDLE position and eight running notches. Its position is shown by indicator above handle.
 - (a) Advance Throttle Handle into each succeeding notch by moving handle slightly toward IDLE and then move into the succeeding notch. This action releases the latch which prevents rapid notching.
 - (b) The Throttle Handle can be returned to IDLE as rapidly as desired.

B. SELECTOR HANDLE

- I. Has an OFF position with four MOTORING positions to the left and a BRAKING range to the right. Its position is shown by indicator at top of controller.
 - (a) Handle in OFF position disconnects traction motors, power and braking circuits.
 - (b) Handle in MOTORING positions makes the following traction motor connections:
 - No. 1 - Series-Parallel.
 - No. 2 - Series-Parallel Shunted Fields.
 - No. 3 - Parallel
 - No. 4 - Parallel Shunted Fields.
 - (c) Handle in BRAKING range provides control of dynamic braking. If locomotive is not equipped with dynamic braking a stop on the controller prevents movement of the handle into the braking range.

C. REVERSE HANDLE

- I. Has three positions, FORWARD, OFF and REVERSE for selecting the desired direction of locomotive movement.

D. MECHANICAL INTERLOCKING BETWEEN HANDLES

I. THROTTLE HANDLE

- (a) Can be moved from IDLE position only with Selector Handle in I, 2, 3, or 4, and Reverse Handle installed.

2. SELECTOR HANDLE

- (a) Can be moved from OFF to the No. 1 position regardless of Reverse Handle position.
- (b) Can be moved to position No. 2, No. 3 or No. 4 only when Reverse Handle is FORWARD or REVERSE.
- (c) On units equipped with dynamic braking the Selector Handle can be moved into the braking range only when Reverse Handle is FORWARD or REVERSE and Throttle Handle is in IDLE.

3. REVERSE HANDLE

- (a) Can be moved only when Throttle Handle is in IDLE, and with the Selector Handle in any MOTORING position.
- (b) Can be installed or removed only when in OFF position.

IV PREPARING FOR OPERATION

A. BEFORE BOARDING

1. Check fuel supply.
2. Check steam generator water supply (if used).
3. Check proper positioning of angle cocks and shutoff valves, also for liquids leaking from external piping.
4. Check for loose or dragging parts.

B. ENGINE COMPARTMENT

1. Inspect to see that no rags, tools, lanterns, etc., are near shafts, belts, or other moving parts or electric apparatus. Never use waste on the locomotive.
2. Lubricating Oil Drain Valves must be closed.
3. Check the Diesel engine lubricating oil level. Bayonet gauge should show oil between the high and low marks.
4. Cooling Water Drain Valve must be closed.
5. Check the quantity of water in the cooling water system. The sight

glass attached to the water expansion tank should show water at all times

6. The engine governor operates under hydraulic oil pressure. The reservoir of oil in the governor base is equipped with two sight glasses. The oil level should , not be below line on lower sight glass.
7. The Emergency Fuel Shutoff Valve must be open. If closed, reset by raising the valve stem and slipping the crutch under the raised stem.
8. Place handle on the duplex fuel oil filter to either the horizontal or vertical position, preferably horizontal.
9. Place radiator shutters and fan under automatic control. If operated on manual control, close observance of water temperature should be made. See ENGINE WATER TEMPERATURE CONTROL.
10. Check to insure air compressor governor cutout cock is open.
11. Diesel engine turning gear must be disengaged and locked. This is located at the air compressor end of the engine and mounted directly above the engine crankshaft extension.
12. The Diesel engine Overspeed Reset Button must be IN. 13. Check the air compressor oil level. Maintain the oil level at the full mark on the bayonet gauge with the engine shut down.

C. IN CAB

1. Close Battery Switch by pushing in on the extension handle located to the right of the Control Compartment near the floor.
2. If lights are needed, close necessary circuit breakers on Control Compartment Panel and toggle switches on Engineman's Control Stand.
3. Move Throttle Handle to IDLE.
4. Move Reverse and Selector Handles to OFF.
5. The Ground Relay Cutout Switch must be closed and the ground relay indicator target must not show red. If tripped, see GROUND RELAY instructions.
6. The Traction Motor Cutout Switch (if used) should indicate "All In". If in any other position see TRACTION MOTOR CUTOUT SWITCH instructions.

D. STARTING DIESEL ENGINE

1. Close Battery Switch.
2. Place Throttle Handle in IDLE, Selector and Reverse Handles in OFF.

3. Close all circuit breakers on the Control Compartment Panel.
4. Close the Control and Fuel Pump Breakers on Engineman's Control Stand. Allow pressure to build up to 35-45 psi on Fuel Oil Pressure Gauge mounted on Gauge Panel in front of engineman's position.
5. Turn Engine Control Switch to IDLE. Low oil pressure green light will light and alarm bell will ring until engine is started and oil pressure is raised to 7 psi or higher. The Engine Control and Start Switches are both mounted to the right on the Control Compartment.
6. Turn Start Switch to the left to crank engine. Hold in this position while cranking the engine until oil pressure shows on gauge, alarm stops and green light goes out. WARNING: Releasing the Start Switch before the green light goes out will stop the engine. If this happens, engine must be allowed to come to a complete STOP before repeating the above starting procedure.
7. Do not discharge battery by repeated attempts to crank. If the first two or three attempts are not successful, recheck complete starting preparation.
8. Check Lubricating Oil Pressure Gauge on Gauge Panel for 20 psi minimum pressure.
9. Open Crankcase Exhauster Circuit Breaker located on Control Compartment Panel.
10. Check engine lubricating oil level. Keep level at the HIGH mark on the bayonet gauge with the engine idling, crankcase exhauster shut off and the locomotive on a level track.
11. Close Crankcase Exhauster Circuit Breaker.
12. Make sure Crankcase Exhauster Light on Control Compartment Panel is ON.
13. Move Engine Control Switch to RUN position.

E. BEFORE MOVING A TRAIN

1. Install Brake Valve Handles and Reverse Lever.
2. Check main reservoir air pressure.
3. Check control air pressure - normal 70 psi.
4. Place Brake Pipe Cutout Cock in LIVE position.
5. Make brake application, release Hand Brake.
6. The Dead Engine Cock located on the distributing valve must be in LIVE position.
7. Test sanders.
- 7A. Open No. 4 cutout cock in release pipe.

8. Make air brake test.
9. Have at least 120° F water temperature, if possible, before notching up.

V OPERATING PROCEDURE

A. MOVING A TRAIN

1. Close Generator Field Breaker on Engineman's Control Stand.
2. Move Reverse Handle to FORWARD or REVERSE position, depending on direction desired.
3. Move Selector Handle to Position I , (or to Position 4 if locomotive is equipped with automatic transition).
4. Release brakes.
5. Open Throttle.

B. STOPPING A TRAIN

1. Close Throttle Handle to IDLE and apply air brakes. If leaving engineman's position move Selector and Reverse Handles to OFF.

C. REVERSING LOCOMOTIVE

1. Bring locomotive to a full stop.
2. Move Selector Handle to No. I position if locomotive is equipped with manual transition, not necessary if automatic transition is used.
3. Move Reverse Handle to opposite direction.
4. Release brakes.
5. Open Throttle.

D. SHUTTING DOWN DIESEL ENGINE

1. Open Generator Field Breaker located at Engineman's Control Stand.
2. Move Engine Control Switch to OFF position.
3. Apply Hand Brake and release air brakes.
4. Open all other switches and circuit breakers at Engineman's Control Stand and Control Compartment Panel.
5. Open Battery Switch.

E. COUPLING ROAD SWITCHERS EQUIPPED FOR MULTIPLE UNIT OPERATION

1. On Leading Unit:
 - (a) Position all breakers the same as for single unit operation.

2. On Trailing Units:

- (a) Close all circuit breakers on Control Compartment Panel. Make sure that the Control, Fuel Pump and Generator Field Circuit Breakers located on the Engineman's Control Stand are OFF.
- b) Throttle Handle must be in IDLE.
- (c) Selector Handle must be in OFF.
- (d) Reverse Handle must be in OFF and removed.
- (e) Move Independent and Automatic brake valve handles to running position and close No. 4 cutout cock in release pipe.
- (f) Move Brake Pipe Cutout Cock to TRAIL position.

3. On Both Units:

- (a) Engage couplers.
- (b) Connect air hoses and multiple-unit jumpers between units.
- (c) Open air line angle cocks.

F. MANUAL TRANSITION

When starting a train with a Road Switcher equipped with manual transition, move the Selector Handle to position I. As the speed increases, the pointer on the speedmeter will move to zones 2, 3 and 4 at which time move the Selector Handle to its corresponding positions 2, 3, or 4:

As locomotive speed decreases move Selector Handle to the corresponding position indicated on the transition scale. The Selector Handle may be moved to any motoring position regardless of the Throttle position.

The speed range for each Selector Handle position and for various locomotive gearing is shown in the following table. These speed ranges are shown by the zones I, 2, 3 and 4 on the Speedmeter or Speed Recorder, if used.

SELECTOR HANDLE POSITION	GEARING-MPH			
	For Locomotive Maximum Speeds of (4 Motor Equipment-40 Inch Wheels)			
	65	75	80	92
1	0-17	0-19	0-21	0-24
2	17-23	19-27	21-29	24-33
3	23-49	27-55	29-60	33-68
4	49-65	55-75	60-80	68-92

G. AUTOMATIC TRANSITION (if used)

When starting a train with a Road Switcher equipped with

automatic transition, move the Selector Handle to position 4. This permits automatic transition to take place at predetermined locomotive speeds during acceleration or deceleration.

The approximate speeds at which the transition relays function or at which the engineman may move the Selector Handle to enforce manual supervisory control over the automatic, are as shown in the following table.

MOVE SELECTOR HANDLE FROM	GEARING ----- MPH				
	For Locomotive Maximum Speed of (4 Motor Equipment 40 Inch Wheels)				
Acceleration	Deceleration	65	75	80	92
1 to 2	2 to 1	17	19	21	24
2 to 3	3 to 2	23	27	29	33
3 to 4	4 to 3	49	55	60	68

H. THROTTLE HANDLING

An inherent feature of the 1600 HP Road Switcher provides throttle control of tractive effort. This offers two advantages. First, it affords the engineer the ability to control, by throttle notch position, the amount of tractive effort to be developed. Second, it provides a positive protection against excessive load current on the traction motors and generator.

The proper use of this feature offers much in improved train handling as well as protection to the electrical equipment. It is important therefore that the engineer thoroughly understand its proper use, since it does require slightly different throttle handling than for other types of locomotives not so equipped.

1. How It Works

For each throttle position a definite maximum load current and corresponding tractive effort may be developed. The increase, as the throttle is advanced from one position to the next, is made immediately but smoothly. Since, however, the total tractive effort of the locomotive is divided into eight steps available on the eight throttle notches, it is necessary to advance all the way into the 8th notch in order to develop full tractive effort. Further, since maximum current is controlled, it is perfectly safe, so far as electrical or mechanical equipment is concerned, to advance the throttle rapidly into the 8th notch: in fact this is not only desirable, but necessary under certain starting conditions.

2. How It Is Used

It is well understood that the worst treatment that can be given a traction motor is to allow it to stand at "stall" condition for any appreciable length of time with load current applied to it. It is therefore most important, having given due care to insure that the brakes are released and that train slack is out to:

- (a) Start the locomotive to move as quickly as possible; and
- (b) Accelerate to a speed which will bring the loadmeter pointer down into the Green zone in a minimum time. Therefore, in making a start, since there is no danger of excessive load current, the throttle should be advanced promptly to a notch that will start locomotive movement. If after starting, acceleration is too fast or until it is certain that all slack is out, the throttle may be backed off as required to maintain desired locomotive speed. As soon as the slack is out, the throttle may be advanced as fast as desired to suit operating conditions. It is good practice to hesitate at each notch position to allow the engine to come up to the new notch speed which is indicated when the loadmeter pointer has come to rest at the new position.

3. Starting Passenger or Light Trains

For normal starting of passenger and light trains, no appreciable difference in throttle handling will be noted from other types of equipment except the immediate response obtained for each throttle notch advance.

4. Normal Starting of Heavy Freight Trains

Normally it is not necessary to "bunch" the slack. If the train is known to be stretched, as soon as the brakes are fully released, throttle should be advanced immediately to whatever notch is required to start movement. Then adjust up or down to suit desired operating conditions bearing in mind desirability of accelerating the train to where the loadmeter registers in the Green zone in minimum time. For normal level grade starting, if no movement is obtained when the throttle has reached 5th or 6th notch, shut off throttle and recheck to insure that the brakes are fully released.

5. For Starting Heavy Trains on Severe Grades

It is occasionally necessary to take as much as the 7th or 8th notch to make a start. The engineer must, of course, use due care in handling the

train slack and to time his power application to insure that brakes are released. Having assured himself of slack and brake conditions, he should have no hesitancy in advancing the throttle quickly into even the 8th notch to get the train moving. While the load current will be high, the control protects against any damaging excess. The important thing is to get the locomotive moving and thus keep to a minimum the length of time during which heavy load current is applied to the motors before they start to turn.

1. WHEEL SLIP

- 1. Wheel slip is indicated by a warning light and buzzer. The occasional wheel slip will be corrected by automatic power reduction and smooth reapplication.
- 2. Upon repeated slip indication, apply sand.
- 3. If this does not correct slipping, reduce throttle.
- 4. When a spinning slip develops it cannot be arrested by sand application. Throttle must be reduced until spinning stops, then apply sand and re-apply power.
- 5. The loadmeter is another means by which a wheel slip may be detected. A sudden drop of the loadmeter pointer or an abnormally low reading may be an indication of wheel slip.
- 6. In multiple-unit operation under adverse rail conditions, excessive wheel slip can be avoided by, placing the Engine Control Switch of the lead unit in the number 6 position.
- 7. A continuous wheel slip warning may indicate a locked axle. Check should be made to insure free rotation of all wheels.

J. OPERATING WITHOUT LOADMETER

If the loadmeter becomes inoperative the following table gives the approximate minimum speeds at which the locomotive may be operated continuously in the 8th notch.

APPROXIMATE MINIMUM CONTINUOUS SPEEDS		
8th Notch Operation - 40-inch Wheels		
MAX. SPEED-MPH	GEAR RATIO	MIN. SPEED-MPH
65	74/18	8.5
75	65/18	10.0
80	64/19	10.5
92	62/21	12.0

VI AIR EQUIPMENT

A. 6-SL AIR BRAKE EQUIPMENT

The 6-SL brake equipment is used on road switchers. Details of this equipment vary on different railroads to meet specific operating requirements.

The equipment consists primarily of the automatic brake valve, independent brake valve, bell ringer valve, sander valve, brake pipe cutout cock, feed valve and distributing valve.

1. The automatic brake valve is the H6-V - having the same positions and functions as the red top brake valve used with steam locomotives.
2. Brake Pipe Cutout Cock located on the back side of the brake valve body is used to open or close the passage between the brake valve and brake pipe. When the handle is vertical, the brake valve is cut out or closed; when the handle is parallel with the floor, it is cut in or open.

3. Brake Pipe Cutout Cock on locomotives equipped for multiple-unit operation has three operating positions: "lead", "trail" and "dead". The handle should be correctly positioned in accordance with unit operation. A spring loaded latch provided in the handle locks it into position, preventing accidental movement.
4. Feed Valve attached to the brake valve body regulates pressure in the brake pipe with the automatic brake valve handle in "running" or "holding" position.
5. Independent Brake Valve Handle has two positions, "running" and "application" zone. It is of the self lapping type. No fanning of the brake valve handle is necessary as the valve automatically builds up the application pressure to the amount corresponding to the handle position and then laps. The release of the locomotive brakes may be made after an automatic brake application by depressing the independent brake valve handle in "running" position.
- b. Distributing Valve located under the cab floor on the right side of the locomotive is the automatic valve mechanism which controls the operation of the brakes on the locomotive in accordance with the movements of both brake valve handles.
7. Dead Engine Cock is mounted on the distributing valve to be open when a locomotive is to be hauled "dead" in a train and closed under all other conditions.

B. AUXILIARY AIR EQUIPMENT

1. Locomotive Bell Valve
 - (a) The Control Valve is located on the right side of the brake valve pedestal and controls the air from the main reservoir for operating the pneumatic bell ringer.
 - (b) The shutoff valve is built in the needle valve adjustment of the bell which is located behind the right front corner steps.
2. Horn Valve
 - (a) The control valve is located at the engineman's position and controls the main reservoir air pressure to the horn.

- (b) The horn shutoff cock is located under the cab floor on the right hand side of the locomotive behind the hinged cover plate on the outside of the cab.
- 3. Sander Valve
 - (a) Located on the left side of the brake valve pedestal, provides sand to the front of leading truck and to rear of trailing truck.
 - (b) The valve has three positions, Forward, Neutral and Reverse. Move handle to right for forward sanding and to left for reverse sanding.
 - (c) If unit is equipped for M-U operation, either position of the sander valve will provide sand to all units for the direction of locomotive movement.
 - (d) On locomotives equipped for M-U operation sanding is automatic when the automatic brake valve handle is moved to emergency.
 - (e) A sander cutout cock for each truck is located under the chassis near the sander automatic valve.
- 4. Windshield Wiper Valves
 - (a) A needle valve located at each of the four windshield wipers provides independent control of speed.
 - (b) The shutoff globe valve for air supply to wipers is located in the bottom of the Engineman's Control Stand and reached by removing the lower cover plate.

VII MISCELLANEOUS OPERATING INSTRUCTIONS

A. CHANGING OPERATING ENDS

1. On Unit Being Cut Out

- (a) Make full service application with automatic brake valve.
- (b) Place brake Dive cutout cock in Trail position.
- (c) Move both brake valves to running position, close No. 4 cock in release pipe.
- (d) Place Reverse Handle in Off position and remove. To do this, Selector Handle must be Off and Throttle in Idle.
- (e) On the Engineman's Control Stand, open the Control and Generator Field Breakers leaving the Fuel Pump Breaker closed.

2. On Unit Being Cut In

- (a) Insert Reverse Handle in controller and leave in Off position.
- (b) Move independent brake valve to Application position.
- (c) Place brake pipe cutout cock in Lead position.
- (d) Open No. 4 cutout cock in release pipe.
- (e) Close Control and Fuel pump breakers on Engineman's Control Stand.
- (f) Open the Fuel Pump Breaker on Engineman's Control Stand ON UNIT BEING CUT OUT.,
- (g) Close Generator Field breaker.

B. DYNAMIC BRAKING OPERATION (if used)

- 1. When operating in Dynamic Braking the engineman controls the amount of braking effort with the selector handle. The Dynamic Brake may be applied with the locomotive operating in either forward or reverse motion. The position of the pointer on the Braking Scale of the loadmeter indicates the amount of braking effort being developed. Continuous braking may be maintained at any value within the Green zone of the Braking scale, except as described under "Dynamic Braking Limits". No operation is permitted in the Red zone of the Braking scale. If the pointer goes into the Red zone the Brake Warning Light will come on and the gong will ring. Braking MUST be reduced to keep the pointer in the Green zone and the alarm off.

The operation and effect of the dynamic brake on the train is similar to that of the locomotive independent air brake; braking effort is applied to the locomotive only. The same precautions for bunching the slack and preventing slack "run out" are required.

2. Dynamic Braking Limits

Any amount of braking may be employed for unlimited time so long as the Loadmeter pointer stays within the Green zone and the Brake Warning Light and Alarm Bell do not operate. No operation is permitted in the Red zone of the braking scale or with the Brake-Warning Alarm on. At speeds above 60 MPH, on 65 MPH geared locomotives, maximum braking should be reduced from the Red band to the Yellow marker on the braking scale of the Loadmeter.

See the following table for corresponding speeds for other gearing.

DYNAMIC BRAKING LIMIT

Top Speed Gearing	Restrict to Small Marker Above
65 MPH	60 MPH
75 MPH	68 MPH
80 MPH	73 MPH
92 MPH	84 MPH

3. To Apply Dynamic Braking:

- (a) Move Throttle to Idle.
- (b) Have Reverse Handle Forward or Reverse depending on direction of motion.
- (c) Move Selector Handle to Off and then to big "B" in the Braking range. Loadmeter Pointer will show slight movement.
- (d) Bunch train slack by advancing Selector Handle cautiously into the Braking range. Do not allow Loadmeter Pointer to exceed the first White mark on the Motoring Scale until all slack is bunched.
- (e) After slack is bunched advance Selector Handle into Braking range until the desired braking effort is obtained. Make handle movements slowly. Do not permit Loadmeter Pointer to enter Red band on the braking scale. If the Brake Warning Alarm comes on, reduce braking until alarm stops.
- (f) The amount of braking effort obtainable varies with the train speed. To obtain maximum braking performance, the Selector Handle must be moved to maintain the Loadmeter Pointer near the top of the Green Band.

With the Loadmeter Pointer held constant, the braking effort will increase as speed decreases until it reaches maximum value at approximately 22 MPH for 65 MPH gearing. Below this speed, braking effort will gradually fall off to reach 0 at 0 MPH.

The speed at which the maximum braking effort is reached for other gearings is as follows: 25 MPH for 75 MPH gearing, 27 MPH for 80 MPH gearing and 30 MPH for 92 MPH gearing.

- (g) It is permissible to start from a standstill on a downgrade with dynamic brake applied.
- (h) When braking a heavy train on a severe grade, the maximum

dynamic braking may not be sufficient to hold the desired train speed. An application of the Automatic air brake may be used in addition to the dynamic to maintain desired train speed. However, Locomotive Brakes **MUST BE HELD OFF** by depressing the Independent Brake Valve Handle to avoid sliding the locomotive wheels.

4. Release of Dynamic Brake

- (a) Reduce braking slowly; pause when the Loadmeter pointer indicates at the first White mark on the Motoring scale to prevent slack run out.
- (b) Handle can now be moved to Off or into Motoring.
- (c) A light application of the Independent Air Brake will aid in preventing slack runoff.

5. Cutout of Dynamic Brakes

- (a) If the Engine Control Switch is turned to Idle, dynamic braking on that unit will be inoperative.
- (b) Cut out dynamic brake only when Selector Handle is Off; this avoids surges on the equipment or on the train. For the same reason, dynamic brake must not be cut in, except with Selector Handle in "Off".

6. Dynamic Braking With Lead Unit Idling or Shut Down

The loadmeter will not operate, therefore the alarm light and gong will indicate when maximum braking has been reached. Reduce braking to stop the alarm. Whenever lead unit is cut out, keep engine idling if conditions permit. This maintains battery charging, air pressure, engine temperature, etc.

(a) Conditions in Leading Unit

- (1) Place Engine Control Switch in Idle or Off.
- (2) Close fuel pump breaker on Engineman's Control Stand.
- (3) Close Main Control Positive and Negative as well as MG breakers on Control Compartment Panel.
- (4) When engine must be shut down completely, open fuel pump and crankcase exhauster breakers on Control Compartment Panel.

(b) Conditions on Trailing Units

- (1) Same as for normal operation.

C. BRAKING WITH POWER

- I. Gradually apply automatic brake for a light brake pipe reduction.

2. Release locomotive brakes by depressing independent valve handle in the Running position.
3. Reduce throttle to maintain Loadmeter pointer in Green band of Motoring scale as train speed decreases. Move throttle to Idle before train comes to a dead stop.
4. On locomotives equipped with manual transition move the Selector Handle into the position indicated by the speedmeter.

D. FASTER AIR PUMPING

1. Generator Field breaker located on Engineman's Control Stand must be Off.
2. Reverse Handle must be in Off position.
3. Selector Handle must be in Position I.
4. Open throttle as desired up to Notch 5.

E. EMERGENCY ENGINE SHUT DOWN

A red Stop Button is located on the Engineman's Control Stand. It will shut down a single engine or simultaneously all engines of a multiple unit locomotive. It is provided primarily for "emergency" use. Normal shut downs should be made with the Engine Control Switch.

To restart engines of a single or multiple unit locomotive after shut down by emergency Stop Button:

1. Locomotives having Single Stop Button.
 - (a) Turn Engine Control Switch to Off on ALL units before attempting to start any unit.
 - (b) Start all engines in usual manner.
2. Locomotives having Double Stop Button (Stop-Run)
 - (a) Reset Stop Switch by pushing in Run button.
 - (b) Start each engine in usual manner. It is not necessary to turn Engine Control Switch to Off on other units before starting any unit.
3. If the locomotive is made up of units of both types, make sure all Run buttons are pushed in then follow starting procedure in Item I above.

F. OPERATING THROUGH WATER

Do not exceed 2 or 3 MPH if there is water above the railhead. Do not pass through water over 4 inches above railhead.

G. PASSING OVER RAILROAD CROSSINGS

The severe mechanical shocks received by traction motors when passing over railroad crossings at high speed may cause the brushes to bounce and flash-over the traction motors. At high speeds, reduce throttle to

5th notch or below while all units pass over the crossing. This is not necessary at slow speeds.

H. TAKING DIESEL ENGINE "OFF THE LINE" IN M-U OPERATION

Turn the Engine Control Switch to IDLE position. If it becomes necessary to stop the engine, turn Engine Control Switch to OFF position and open the fuel pump switch on the Control Compartment Panel.

I. PUTTING DIESEL ENGINE "ON THE LINE" IN M-U OPERATION

If engine has been shut down:

1. Close fuel pump switch on Control Compartment Panel.
2. Start Engine in usual manner.

If lead unit throttle is in Idle, turn Engine Control Switch directly to Run.

If lead unit throttle is in a Running Notch, turn Engine Control Switch slowly to Run pausing 3 seconds at intermediate positions 2, 4, and 6 to gradually bring engine up to speed and load.

J. PARTIAL LOAD OPERATION

The Diesel engine may be operated at partial load by moving the Engine Control Switch to position 2, 4, or 6 regardless of throttle position.

Position 2, 4, or 6 corresponds to throttle notch 2, 4, or 6. After setting the Engine Control Switch at any of these intermediate points, the Diesel engine speed will increase only up to that point although the throttle may be in a higher notch. The positioning of the Engine Control Switch thereby limits the output of the Diesel engine.

In M-U operation this feature provides for:

1. Reduced power on the lead unit to overcome excessive wheel slip under adverse rail conditions.
2. Reduced power operation of any unit to accommodate power plant difficulties which may make full power operation undesirable.
3. Reduced power break-in of an overhauled engine.

K. TOWING DEAD LOCOMOTIVE

In freezing weather, drain engine and steam generator (if used) water systems. Brake equipment on one or more "dead" units which are in multiple with a "live" leading unit should be set up the same as "live" trailing units.

It is recommended that brake equipment on each unit of a "dead" multiple unit locomotive which is not in multiple with a "live" unit should be set up as a single "dead" unit as follows:

1. Close brake pipe cutout cock on brake valve pedestal "dead" position if unit is equipped for M-U operation.
2. Place automatic and independent brake valve handles in "running" position.
3. Place throttle in Idle, selector and reverse handles in Off position- remove reverse handle.
4. Place dead engine cock in "dead" position.
5. Set safety valve on distributing valve for 25 psi.
6. Connect brake nine hose on iv
7. Open No. 4 Cutout Cock in release pipe.

L. OPERATING WITH STEAM LOCOMOTIVE HELPER

Before using a steam locomotive as a helper, it should first be determined that the steam locomotive can pull its share of the tonnage at or above the rated speed of the Diesel-electric locomotive. The tonnage rating of steam locomotives used in helper service is sometimes based on speeds below the continuous rated speed of the Diesel-electric locomotive.

It therefore follows that if the helper locomotive can not pull its share of the tonnage which is in excess of the continuous tonnage rating of the Diesel-electric locomotive, the Diesel-electric locomotive will endeavor to pull more than its share which may result in eventual damage to the equipment.

When operating with a helper watch the loadmeter; overloading of the Diesel-electric locomotive will be indicated by the loadmeter pointer moving into the Red zone. Reduce the Diesel-electric locomotive throttle and allow the train speed to drop until the helper locomotive assumes its share of the tonnage; then set the Diesel-electric locomotive throttle in the position that allows the loadmeter pointer to remain in the upper part of the Green zone.

M. DOUBLE HEADING BEHIND STEAM LOCOMOTIVE

When preparing for double heading a Diesel-electric locomotive behind a steam locomotive, make a full service application and close the brake pipe cutout cock. If unit is equipped for M-U operation, place brake pipe cutout cock in "dead" position. Brakes are then controlled from the steam locomotive but the engineman on the Diesel-electric locomotive can make an emergency application by moving the automatic brake valve handle

to emergency position. He can release the brakes by depressing the independent brake valve handle.

N. OPERATING WITH LEAD UNIT DOWN

1. Turn Engine Control Switch on lead unit to Off.
2. Close battery switch on lead unit.
3. Close main Control Positive and Negative Breakers on the lead unit Control Compartment Panel -and Lighting Breakers only as required.
4. Close Auxiliary Generator Breaker (or Battery Breaker) on lead unit Control Compartment Panel.
5. Open all other circuit breakers on lead unit Control Compartment Panel.
6. Close Control, Fuel Pump and Generator Field Breakers on the lead unit Engineman's Control Stand.
7. Dynamic braking will be inoperative on lead unit. (See Dynamic Braking with Lead Unit Down.)

Note: With engine dead, battery charging generator ceases to function. The battery voltage will weaken enough in a few hours to prevent further locomotive operation.

O. OPERATING WITH DEAD BATTERY ON LEAD UNIT (Without Headlight)

1. Turn Engine Control Switch on lead unit to Off.
2. Open battery switch on lead unit.
3. Open all circuit breakers on Control Compartment Panel and Electric Cab Heater Circuit Breaker (if used).
4. Open Fuel Pump and Control Breakers and close Generator Field Breaker on Engineman's Control Stand in lead unit.
5. On any ONE of the TRAILING UNITS, close Fuel Pump and Control Breakers on Engineman's Control Stand.
6. Dynamic Brake can not be used.

P. OPERATING WITH DEAD BATTERY ON LEAD UNIT (With Headlight).

On Lead Unit:

1. Turn Engine Control Switch to Off.
2. Open battery switch.
3. Open Electric Cab Heater Circuit Breaker (if used.)
4. Open all circuit breakers on Control Compartment Panel except Headlight, Cab Light and Engine Room Light Breakers.

5. Open Fuel Pump and close Generator Field and Control Breakers on Engineman's Control Stand.

On Any One Trailing Unit

1. Close Fuel Pump and Control Breakers on Engineman's Control Stand.

2. Make sure all circuit breakers on Control Compartment are closed.

Caution: DO NOT use more than one headlight-Control Breaker may trip.

Q. ENGINE WATER TEMPERATURE CONTROL

The engine water temperature is controlled by a single radiator fan and a pair of radiator shutters located on the right and left sides of the loco-

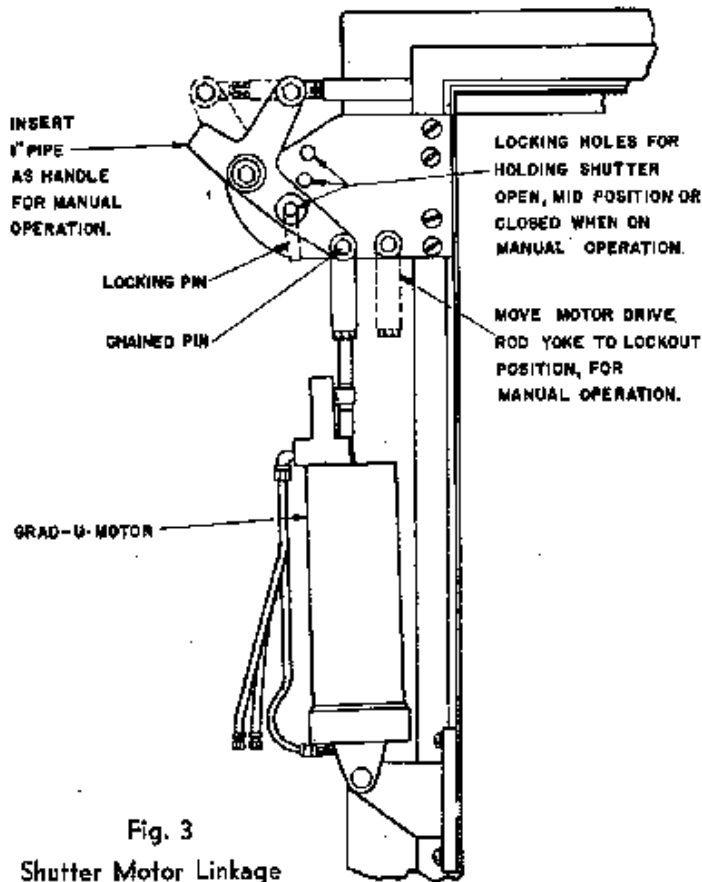

Fig. 3
Shutter Motor Linkage

otive at the forward end. The speed of the fan and the positioning of the shutters are automatically controlled by the temperature of the water entering the Diesel engine. In the event of high water temperature or by inspection, it was found that either the fan or shutters or both were not functioning, the equipment can be operated manually.

For automatic operation, the radiator fan control switch should be in "automatic" position on the control panel mounted under the hood on the left back side of the radiator compartment bulkhead. Both shutter motor drive rod yokes (Fig. 3) should be connected to the shutter operating links with link locking pins removed and placed in receptacle in the inside of the hinged cover. Both cutout cocks (Fig. 4)

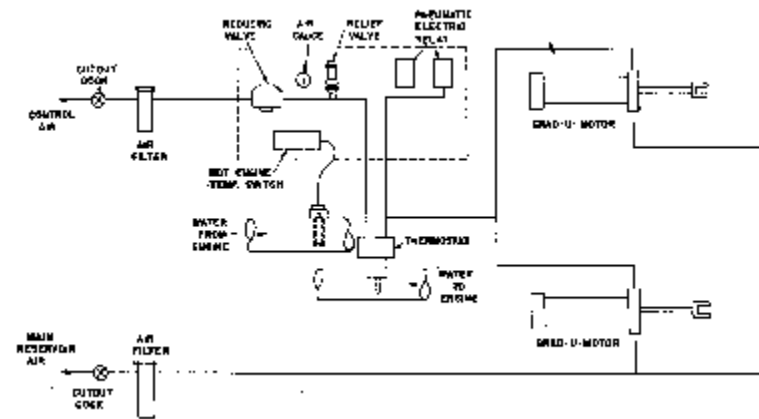

Fig. 4
Schematic Arrangement - Engine Temperature Control

should be open and the air pressure gauge should show 15 psi with the shutters closed and the fan not operating.

In an emergency, the equipment can be operated manually by first closing the cutout cocks to both air filters and then bleed the system by opening the drain valve in the base of each filter. Remove one inch pipe from receptacle on walkway and apply to stub end of shutter operating link. Lift up on pipe and remove chained pin from shutter motor yoke. Place yoke in lockout position and reapply chained pin. Position shutter operating link with locking pin in one of the three holes provided for a full open, mid-position or full closed shutter and fan control switch to "Off", "Medium" or "Full" fan speed to maintain 140° to 160° F engine water temperature.

R. REVERSER EMERGENCY OPERATION

If the reverser fails to operate, turn Engine Control Switch to Idle on the unit affected. Try throwing the reverser by pressing the magnet valve buttons. Left magnet valve for Forward - Right magnet valve for Reverse.

If this is not effective, remove manual operating handle from clips on reverser frame. Insert handle in hole provided in operating lever on top of operating shaft and move to left for Forward movement and to the right for Reverse movement.

Note: The radiator end of the Road Switcher unit is classified as the Forward end. Therefore if the steam generator end of the unit is leading, the reverser must be set for Reverse movement.

S. TRACTION MOTOR CUTOUT SWITCH (If Used)

The traction motor cutout switch is located in the Control Compartment. It is connected in the control circuits and provides for cutting out:

1. Any ONE motor;
2. The PAIR of motors in either truck.

This permits cutting out a single bad motor, or a truckpair of motors in event of a blower failure.

The throttle must be in Idle before operating this switch. Power of the unit is automatically restricted to approximately two-thirds horsepower when motors are cut out. In event the ground relay trips, the motor cutout switch may be used to isolate motors 2 or 3 to determine location of trouble.

T. HAND BRAKE OPERATION

1. To Apply:
 - (a) Engage latching lever in back of brake wheel.
 - (b) Turn wheel counterclockwise until brake is fully applied.
2. To Release:
 - (a) Turn wheel counterclockwise one-eighth turn.
 - (b) Disengage latching lever.
 - (c) Release wheel.

VIII GAUGES AND INSTRUMENTS

A. LOADMETER

The loadmeter is strictly a color band guide for locomotive operation in motoring and dynamic braking (if used).

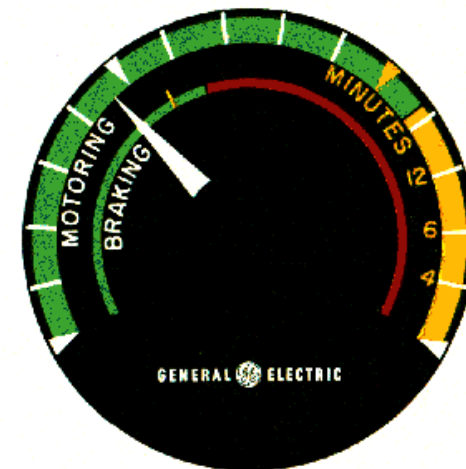

Fig. 2 - LOADMETER

1. Motoring

The pointer position on the Motoring scale indicates the amount of tractive effort being developed or the load on the traction motors when pulling a train.

The Green zone represents normal operation; in this zone operating time is unrestricted. The Yellow zone indicates short time load capacity of the traction motors; operation in this zone is principally for acceleration. The point on this scale where the color band changes from Green to Yellow indicates the Maximum load at which Continuous operation may be maintained.

2. Short Time Load Operation

For operating guidance, on short ruling grades or in emergency, short time load limits are shown by the Yellow figures which appear beneath the Yellow band on the Motoring scale. These figures indicate the Maximum Time in minutes that operation may be maintained when the loadmeter pointer registers at their respective load values. These overload times shall not be used accumulatively and the operator must use his best judgment as to

when he has used up the full allowed time, if for instance the pointer may register part time at say the twelve minute load and part time at some value above or below this point.

When a short time load has been used for the full allowable time, the load MUST then be reduced to where the pointer will register AT OR BELOW THE YELLOW TRIANGLE which appears near the upper end of the Green band. The load must be held below the Yellow triangle for at least twenty minutes before another overload in the Yellow zone may be repeated.

3. Dynamic Braking (If Used).

The Braking scale is the engineman's guide in applying the dynamic brake. For complete instructions see DYNAMIC BRAKE OPERATION.

D. SPEEDMETER

1. Has a Speed Scale and a Transition Scale.

- (a) Speed Scale-Indicates locomotive speed in miles per hour.
- (b) Transition Scale-The outer scale is divided into four zones which correspond to the four Selector Handle positions. The Yellow Marks separating these zones indicate the speeds at which manual transition is performed. See TRANSITION.

C. BATTERY VOLTMETER

1. Has a voltage and color scale.

- (a) Voltage Scale-Indicates voltage of battery circuit.
- (b) Color Scale-Indicates battery circuit condition: Red (first zone)-Faulty or discharged battery. Silver-Battery at low charge or being discharged (normal open circuit voltage is 64 volts). Pointer stay in this band for a short time after starting the engine.
 - Green-Battery receiving normal charge.
 - Red-Battery being overcharged.

D. AUXILIARY GENERATOR AMMETER

Indicates auxiliary generator ampere output. It should show a reading whenever the Diesel engine is running; however, the reading will vary widely depending on the auxiliaries being operated.

If meter shows no reading, check to insure that both Auxiliary Generator and Auxiliary Generator Field circuit breakers on Control Compartment Panel are closed.

If still no reading is shown, minimize auxiliary load to conserve battery.

E. LUBRICATING OIL PRESSURE GAUGE

1. Located on gauge panel in front of engineman's position.
2. Should indicate 20-25 psi at idling speed and 45-55 psi at top engine speed.

F. ENGINE WATER TEMPERATURE GAUGE

1. Located on gauge panel in front of engineman's position.
2. Indicates temperature of cooling water out of left bank header of engine.
3. Normal operating temperature is 140° F to 160° F.

G. BOOSTER AIR PRESSURE GAUGE

1. Located under the hood on the left back side of the radiator compartment bulkhead.
2. Indicates turbosupercharger air pressure to Diesel engine.
3. Should indicate 15-18 psi with throttle in eighth notch with engine fully loaded and lower pressures in lower throttle notches.

H. FUEL OIL PRESSURE GAUGE

1. Located on Gauge Panel in front of engineman's position.
2. Should indicate 35-45 psi at all engine speeds.

I. AIR GAUGES

1. One gauge indicates brake pipe and brake cylinder pressure.
2. The other gauge indicates main reservoir and equalizing air pressure.

J. CONTROL AIR PRESSURE GAUGE

1. Mounted on cab side panel to the rear of the engineman's seat.
2. Should indicate 70 psi.
3. Loss of control air pressure prevents operation of the electro-pneumatic contactors and further locomotive movement.

K. RADIATOR FAN CONTROL AIR PRESSURE GAUGE

1. Mounted in the fan control panel under the hood on the left back side of the radiator compartment bulkhead.
2. It should indicate 15 to 17 psi for operation of the elect ropneumatic fan control switches.

IX AUTOMATIC ALARMS & SAFEGUARDS

In multiple unit operation the Alarm System provides both Gong and Indicating Light warning in all units for the following:

- (a) Low Lubricating Oil Pressure.
- (b) Hot Engine
- (c) Ground Relay Trip.
- (d) Steam Generator-game Out (If Used)

A. HOT ENGINE

1. When engine cooling water temperature reaches 185° F:
 - (a) The Hot Engine (red) indicating light, located on the Control Stand, will light.
 - (b) The alarm bell will sound.
 - (c) The engine will return" to idle.

B. LOW LUBRICATING OIL PRESSURE

1. If oil pressure drops below 20 psi, but remains above 7 psi when. the Throttle Handle is in the 5th to 8th notches; and the Engine Control Switch is in "b" or "Run"; the engine will return to idle, the alarm bell will sound and the low lubricating oil pressure green light on the Engineman's Control Stand will light. If the throttle is reduced to 4th notch or below; or the Engine Control Switch of the affected unit is turned to "4"; the alarm will stop and the engine will assume load up to the 4th notch.
2. If oil pressure drops below 7 psi, the engine shuts down, the alarm sounds and the low lubricating oil green light comes on.

C. GROUND RELAY

1. A ground in the power circuit operates he ground relay to return the engine to idle, sound the alarm bell and light the white ground indicating light on the 'Engineman's Control Stand. A red indicator will also appear on the ground relay. The ground relay may be seen through a window of the relay box located in the upper right corner

of the Control Compartment.

2. To Reset Ground Relay:
 - (a) Turn Engine Control Switch to Idle.
 - (b) Push in Ground Relay Reset Button.
 - (c) Turn Engine Control Switch to Run.
 - (d) Start locomotive; if Ground Relay stays in, continue normal operation.
3. If Ground Relay continues to trip:
 - (a) The Motor Cutout Switch (if used) may be used to isolate a faulty motor circuit on Motors 2 and 3. For example: reset Ground Relay as outlined in 2 above; turn Motor Cutout Switch to position "2-Out" and start locomotive. Follow same procedure for Motor 3.
 - (b) In some cases it may be found that the Ground Relay trips when the throttle is advanced to a certain notch position. In M-U operation, the Engine Control Switch of the affected unit may be turned to limit ,its operation to a notch position below that at which the fault occurs.
 - (c) Under extreme emergency conditions; reset Ground Relay as outlined in 2 above, open GROUND RELAY CUTOUT SWITCH in Control Compartment and move locomotive no farther than is necessary observing for smoke or overheating of electrical equipment., If in M-U operation, the unit should be taken "Off the Line."
 - (d) Repeated Ground Relay tripping may indicate a traction motor failure. This might result in a locked axle. Check should be made to insure that all wheels turn freely,

D. WHEEL SLIP WARNING

1. A wheel slip relay is connected across traction motors 2 and 3 and another across traction motors 1 and 4. When the relays operate, the Wheel Slip Light and Buzzer will operate and power will be automatically reduced and reapplied. For further information, see WHEEL SLIP.

E. DYNAMIC BRAKE WARNING (If Used).

1. When the dynamic braking limit is exceeded, the followingq indications are provided:
 - (a) The loadmeter pointer will enter the Red zone of the BRAKING scale indicating overload on lead unit.
 - (b) The Brake Warning Light and Alarm Gong will operate to indicate overload on the lead unit or any unit in the multiple.

For further information, see DYNAMIC BRAKE OPERATION.

F. CRANKCASE EXHAUSTER

1. The Yellow Crankcase Exhauster Light, located on the Control Compartment Panel, should be On continuously to indicate that the Exhauster is running.
2. If light is Out, see that Crankcase Exhauster Breaker is closed. If breaker is closed and lamp is not burned out, report condition.

G. BOILER FLAME OUT (If Used)

1. If the steam generator stops, the boiler alarm relay closes and causes the White Flame-Out Light to light and the alarm to sound.

H. DIESEL ENGINE OVERSPEED

1. The overspeed switch automatically drops out the governor clutch to shut down the Diesel Engine when it reaches a speed of 1110 plus or minus 10 r.p.m.
2. To reset overspeed switch:
 - (a) Move Engine Control Switch to Off.
 - (b) Push in overspeed switch reset button.
 - (c) Start engine and move Engine Control Switch to Run, pausing three seconds at each intermediate position. If overspeed switch repeatedly trips on any unit, that unit may be operated at partial load by moving the Engine Control Switch to the intermediate position necessary to keep it from tripping.

I. JOURNAL BOX HEAT INDICATOR (If Used).

1. Heat indicators installed in the covers of roller bearing journal boxes emit a pungent odor when journal box temperature reaches 200° F.

X ACCESSORIES

A. CAB HEATER

- (a) Located on right side in front of engineman's position.
- (b) Rheostat switch for controlling heater fan is located on Gauge Panel at engineman's position.
- (c) Inlet and outlet valves are located under the engine hood forward of the Control Compartment.
- (d) Manual vent valve located on top of heater.

INDEX

	A	Page
Air Brake Equipment		18
Air Gauges -----		33
Air Pressure Gauge, Booster -----		33
Air Pumping, Faster -----		24
Alarms and Safeguards		34
Ammeter, Auxiliary Generator -----		32
Automatic Brake Valve -----		18
Automatic Transition -----		14
Auxiliary Generator		7
Auxiliary Generator Ammeter		32
	B	
Battery Voltmeter		32
Before Moving a Train		12
Ball, Locomotive		19
Boiler Flame Out		36
Booster Air Pressure Gauge		33
Brake, Hand		30
Brake Pipe Cutout Cock -----		18
Braking with Power		23
	C	
Cab Heater		36
Changing Operating Ends -----		20
Control Air Pressure Gauge -----		33
Coupling Units for M-U Operation -----		13
Crankcase Exhauster -----		36
Cutout Switch, Ground Relay - -----		35
Cutout Switch, Traction Motor		30
	D	
Data, General -----		6
Dead Battery, Operating Lead Unit with (Without Headlight)		27
Dead Battery, Operating Lead Unit with (With Headlight)		27
Dead Engine Cock .		19
Diesel Engine		7
Diesel Engine Overspeed		36

	Page
Diesel Engine Starting -----	11
Distributing Valve -----	19
Double Heading Behind Steam Locomotive -----	26
Dynamic Brake Application -----	22
Dynamic Brake Cutout -----	23
Dynamic Brake Release -----	23
Dynamic Brake Warning -----	35
Dynamic Braking Limits -----	21
Dynamic Braking Operation -----	21
Dynamic Braking with Lead Unit Down -----	23
E	
Emergency Engine Shutdown -----	24
Engine Overspeed -----	36
Engine Water Temperature Control -----	28
Engine Water Temperature Gauge -----	33
Exhauster, Crankcase -----	36
F	
Faster Air Pumping -----	24
Feed Valve -----	19
Fuel Oil Pressure Gauge -----	33
G	
Gauges and Instruments -----	31
General Data -----	6
Ground Relay -----	34
Ground Relay Cutout Switch -----	35
H	
Handbrake Operation -----	30
Horn -----	19
Hot Engine -----	34
Independent Brake Valve -----	19
Interlocks, Mechanical -----	10
Introduction -----	7

	Page
J	
Journal Box Heat Indicator -----	36
L	
Lead Unit Down, Operating with -----	27
Loadmeter -----	31
Low Lube Oil Pressure -----	34
Lubricating Oil Pressure Gauge -----	33
M	
Manual Transition -----	14
Mechanical Interlocks -----	10
Miscellaneous Operating Instructions -----	20
Moving a Train -----	13
O	
Oil Pressure Gauge, Fuel -----	33
Oil Pressure Gauge, Lubricating -----	33
Operating Procedure -----	13
Operating Through Water -----	24
Operating with Dead Battery on Lead Unit	
With Headlight -----	27
Without Headlight -----	27
Operating with Lead Unit Down -----	27
Operating with Steam Locomotive Helper -----	26
Operating Without Loadmeter -----	17
Operation, Preparing for	
Before Boarding -----	10
In Cab -----	11
In Engine Compartment -----	10
Overseer Switch, Engine -----	36
P	
Partial Load Operation -----	25
Passing Over Railroad Crossing -----	24
Preparing for Operation -----	10
Putting Engine "On the Line" -----	25
R	
Radiator Fan Control Air Pressure Gauge -----	34

Page

Reverser Emergency Operation	30
Reverse Handle -----	9
Reversing Locomotive -----	13
S	
Sander Valve -----	20
Selector Handle	9
Shutting Down Diesel Engine -----	13
Speedmeter -----	32
Starting Diesel Engine -----	11
Steam Locomotive Helper, Operating With -----	26
Stopping a Train	13
T	
Taking Engine "Off the Line"-----	25
Throttle Handle	9
Throttle Handling, -----	15
How It Is Used -----	16
How It Works	15
Normal Starting of Heavy Train -----	16
Starting Heavy Trains on Severe Grades -----	16
Starting Passenger or Light Trains -----	16
Towing Dead Locomotive	25
Traction Generator -----	7
Traction Motor Cutout Switch -----	30
Traction Motors -----	8
Transition	
Automatic	14
Manual -----	14
V	
Voltmeter, Battery -----	32
W	
Water Temperature Control, Engine -----	28
Water Temperature Gauge, Engine -----	33
Wheel Slip	17
Wheel Slip Warning	35
Windshield Wiper Valve -----	20