

ENGINEER'S MANUAL for OPERATING

FAIRBANKS-MORSE

DIESEL ELECTRIC
LOCOMOTIVES



FAIRBANKS, MORSE & CO.
MANUFACTURERS CHICAGO, ILL.

N.C.S.
ENGINEMEN'S MANUAL

FOR OPERATING

FAIRBANKS-MORSE

DIESEL ELECTRIC ROAD LOCOMOTIVE

2000 H.P. CLASS

PENNSYLVANIA RAILROAD



Bulletin 1409

FAIRBANKS, MORSE & CO.
MANUFACTURERS CHICAGO, ILL.

Built at Erie, Pa. Works
General Electric Co.

October, 1947

Printed in U.S.A

TABLE OF CONTENTS

	Page
SECTION 101—DESCRIPTION	
a. General	1
b. Locomotive Controls	1
c. Control Stand Operating Handles and Indicating Equipment	12
d. Transition	15
e. Dynamic Braking	18
SECTION 104—LOCOMOTIVE OPERATION	
a. Preliminary Operations	1
b. Starting Engines and Putting Engines "On the Line"	2
c. Preparation for Moving Locomotive	3
d. Pumping Up Train Line	4
e. Starting Train	4
f. Forestalling Automatic Transition	5
g. Special Instructions—Operation by Manual Transition	5
h. Stopping or Reducing Locomotive Speed	6
i. Dynamic Braking	6
j. Stopping Engines	10
k. Emergencies	10
l. Operating Precautions	11
m. Changing Operating Cabs	11
n. Leaving Locomotive	12
o. Rerailing	13
p. Towing Locomotive Dead in Train	13
q. Periodic Inspection on Road	14
r. Summary of Operating Precautions	16
s. Electrical Precautions	16
t. Operating With One Motor Cut Out	17
u. Operating With One Unit Cut Out	17
v. Diesel Engine Precautions	18
w. Operation With Reduced Diesel Engine Output	18
x. Freezing Weather Precautions	18

LIST OF ILLUSTRATIONS

Section 101

	Illus.	Page
Control Compartment Arrangement.....	7	11
Control Compartment Panel.....	6	10
Control Panel, Fireman's Position.....	4	7
Engine and Generator Set for 2000 HP Diesel Electric Road Locomotive Unit—Control End and Side.....	1	2
Engine and Generator Set for 2000 HP Diesel Electric Road Locomotive Unit—Opposite Control End and Side	2	3
Engine Control Panel.....	5	8
Load-Braking Indicator	12	17
Operating Cab	3	4
Reverse, Selector and Throttle Handle Positions.....	8	13
Selector Handle Latching.....	9	14
Selector Handle Latching—Side View.....	10	14
Speed Transition Indicator.....	12	17
Traction Motor Connections in Selector Handle Positions 1, 2, 3 & 4.....	11	16

From the collection of

Don Nickel

Section 101 DESCRIPTION

a. General

The Fairbanks-Morse OP diesel-electric road locomotive consists of 2000 HP units, coupled together and operated in multiple. The units are designated as "A" or "B" type. Each "A" unit has an operating cab equipped with the controls necessary to operate the locomotive. The "B" units have no cab but are furnished with "hostler control" by which the unit can be moved independently if necessary.

Except for the control equipment, "A" and "B" units are essentially the same. Each contains a 2000 HP Fairbanks-Morse OP diesel engine which drives a main electrical generator, exciter, two auxiliary generators and air compressor. The main generator supplies direct current to four traction motors which are geared to the wheel axles. Two traction motors are located on each truck and are geared to the leading and trailing pairs of wheels. The middle wheel set of each six wheel truck is an idler.

Each locomotive unit is self-contained and operates as a separate power plant under the control of the leading "A" unit. The wires necessary for this control are "trainlined" from unit to unit by removable cables or "jumpers" which carry low voltage electricity only. If necessary, one unit can be cut out and operation continued with the remaining units.

b. Locomotive Controls

1. GENERAL

Following are listed the locomotive controls. These are for manual operation, unless otherwise noted.

Nearly all fuses have been eliminated from this equipment, and circuit breakers used instead. The exception is a 300 amp. fuse in the 250 volt auxiliary generator circuit. These circuit breakers also function as manually operated switches in the various circuits. Automatic tripping on overload is indicated by the position of the handle which is midway between "OFF" and "ON." To reset after tripping, the operating handle or trigger is pressed down to "OFF" and then snapped upward to "ON."

Panel instruments are marked with a fluorescent lacquer which glows under black light illumination from a lighthouse, enabling cabs to be kept in darkness at night. The intensity of the black light is adjustable by means of a rheostat incorporated in the gage light OFF and ON switch.

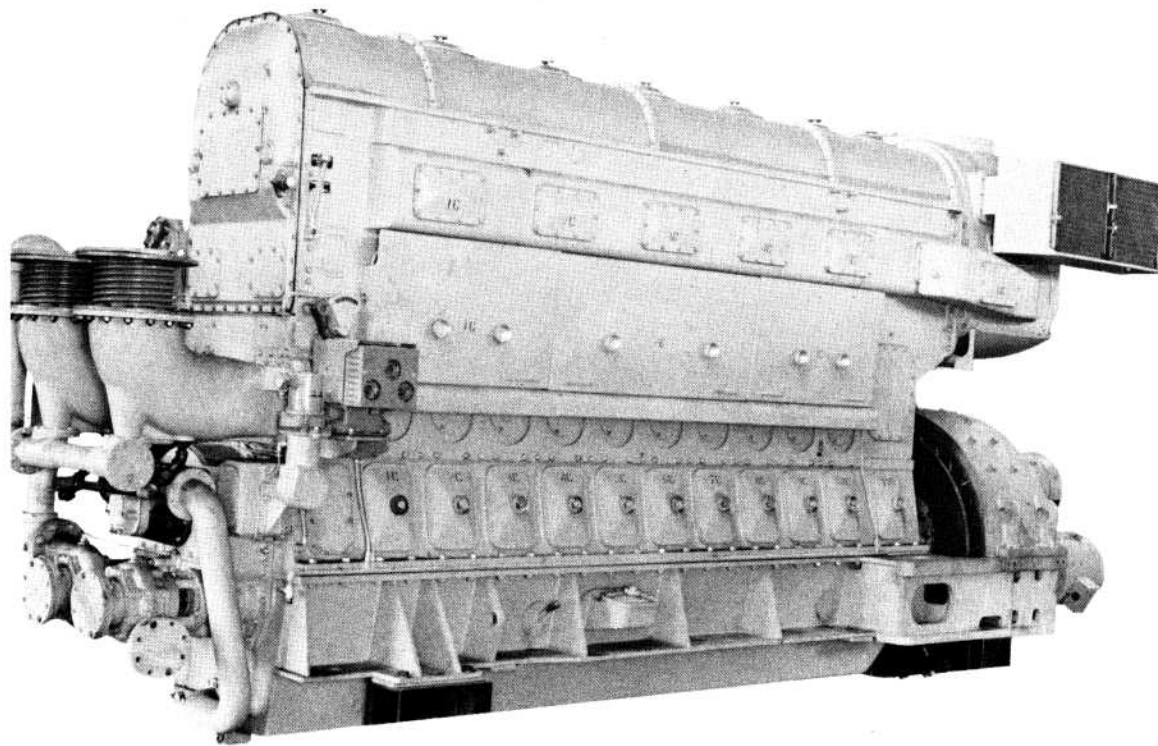

Illus. 1 Engine and Generator Set for 2000 H.P. Diesel Electric Road Locomotive Unit—Control End and Side

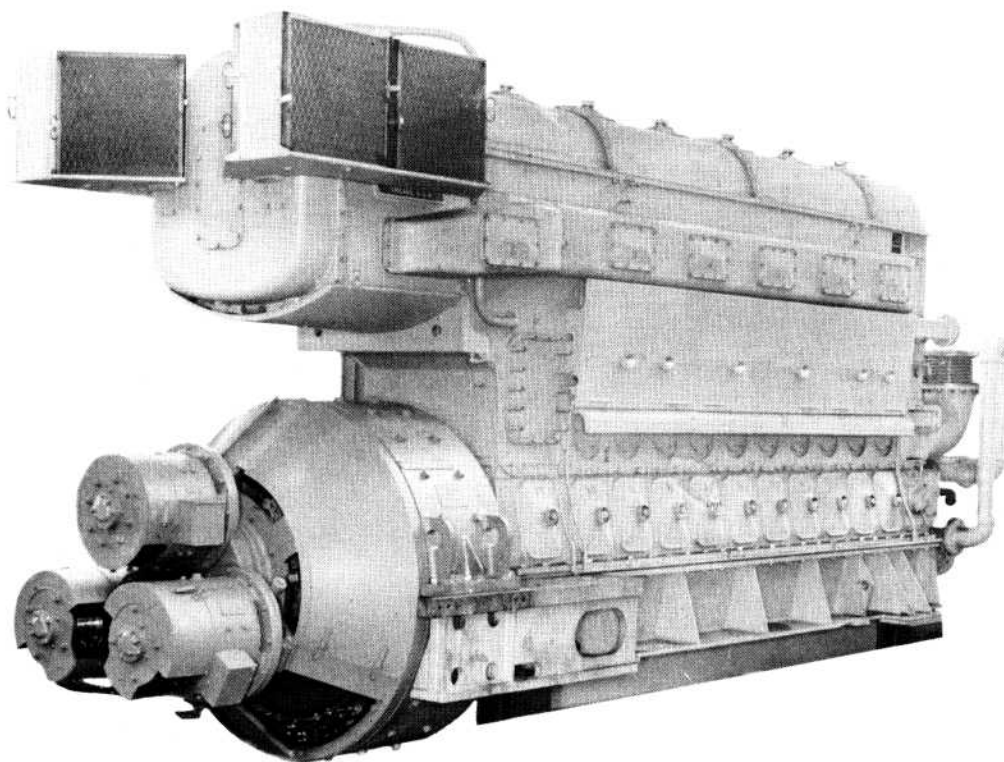

Illus. 2 Engine and Generator Set for 2000 H.P. Diesel Electric Road Locomotive Unit—Opposite Control End and Side

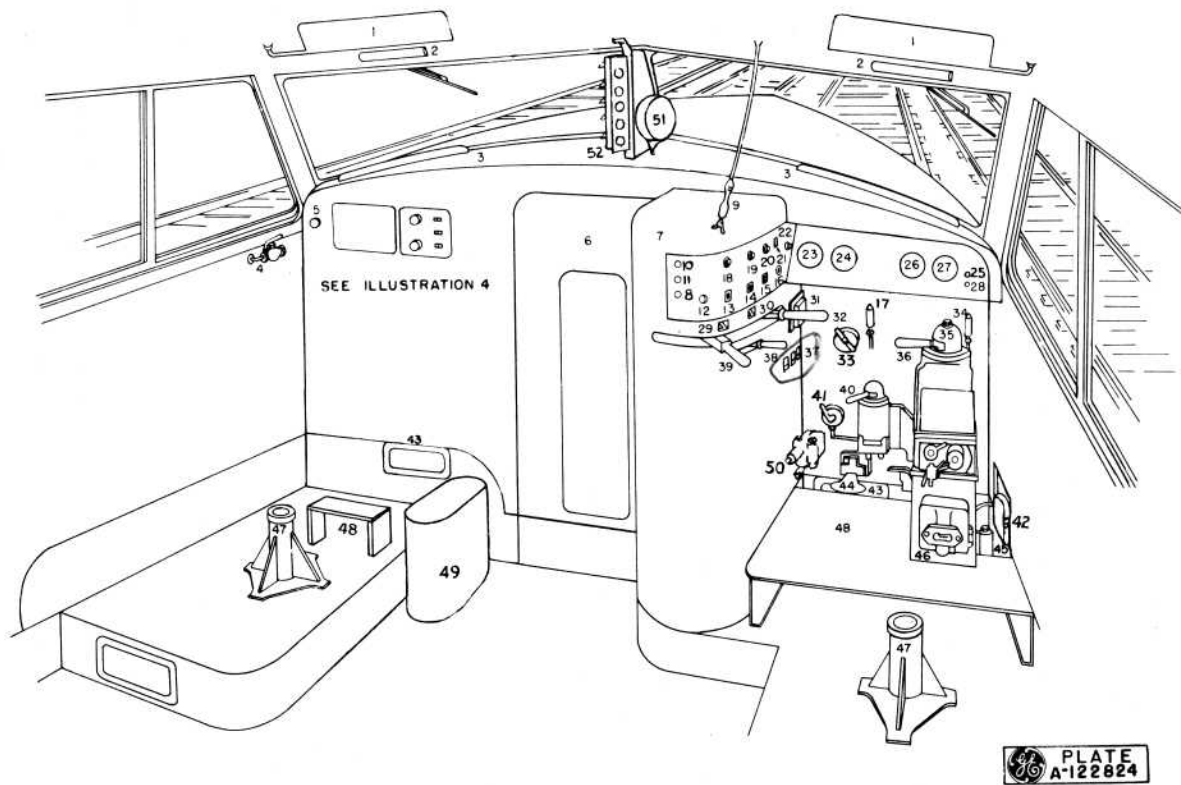

Illus. 3 Operating Cab

- | | |
|--|---|
| 1. Sun Visors | 28. Wheel Slip Indicating Light (white) |
| 2. Windshield Wipers and Motors | 29. Selector Position Window |
| 3. Defroster Openings | 30. Throttle Position Window |
| 4. Conductor's Valve | 31. Wheel Slip Warning Buzzer |
| 5. Windshield Wiper Control Valve | 32. Throttle Handle |
| 6. Door to Hood | 33. Rotair Valve |
| 7. Control Stand | 34. Air Brake Signal Whistle |
| 8. Fire Alarm Warning Light (red) | 35. Automatic Brake Valve |
| 9. Whistle Pull Cord | 36. Automatic Air Brake Handle |
| 10. Hot Engine Indicating Light (red) | 37A. Control Circuit Breaker |
| 11. Low Lube Oil Indicating Light (yellow) | 37B. Cab Signal Circuit Breaker |
| 12. Attendant Call Button | 37C. Fuel Pump Circuit Breaker |
| 13. Headlight Circuit Breaker | 38. Reverse Handle |
| 14. Headlight Bright and Dim Switch | 39. Selector Handle |
| 15. Order Light Switch | 40. Independent Brake Valve |
| 16. Emergency Engine Stop Button | 41. Bell Ringer Valve |
| 17. Train Signal Whistle | 42. Acknowledging Switch |
| 18. Gage Light Switch and Rheostat | 43. Cab Heater |
| 19. Heater Switch and Rheostat | 44. Safety Control Foot Pedal |
| 20. Defroster Switch and Rheostat | 45. First Service Cock |
| 21. Generator Field Switch | 46. Equalizing Piston Portion |
| 22. Windshield Wiper Control Valve | 47. Seat Stands |
| 23. Load-Braking Indicator | 48. Foot Rests |
| 24. Speed-Transition Indicator | 49. Water Cooler |
| 25. Brake Warning Light (white) | 50. Cab Signal Valve |
| 26. Main & Equalizing Reservoir Gage | 51. Loud Speaker |
| 27. Brake Cylinder & Brake Pipe Gage | 52. Cab Signals |

2. ENGINEER'S POSITION (See Illustration 3)**a. Control stand — Operating Handles**

Reverse Handle which controls the direction of locomotive movement.

Throttle Handle which controls the locomotive speed and power.

Selector Handle which is moved to the left from "OFF" position to make manual transitions and to the right from "OFF" position to apply the dynamic brake.

b. Circuit Breakers on Control Stand

Headlight Circuit Breaker

Control Circuit Breaker

Cab Signal Circuit Breaker

Fuel Pump Circuit Breaker

c. Switches and Push Button on Control Stand Panel

Order Light Switch

Headlight Bright and Dim Switch

Generator Field Switch

Gage Light Switch and Rheostat

Heater Switch and Rheostat

Defroster Switch and Rheostat

Attendant Call Button

Engine Stop Button, (Emergency stop for all engines)

d. Warning Lights on Control Stand and Front Panel

Hot Engine (Red)

Low Oil Pressure (Yellow)

Fire Alarm Warning (Red)

Wheel Slip Indicator (White)

Dynamic Brake Overload (White)

e. Other Control Devices on Control Stand

Wheel Slip Warning Buzzer

Illuminated Dials for Controller

Windshield Wiper Control Valve

f. Indicating Instruments on Front Panel (Left to Right)

Load-Braking Indicator

Speed-Transition Indicator

Main and Equalizing Reservoir Gage

Brake Cylinder and Brake Pipe Gage

g. Safety Control Foot Pedal**h. Air Brake Equipment**

Automatic Brake Valve Handle

DESCRIPTION

Cocks on Automatic Brake Valve

1. Double-heading cock

2. Safety control cutout cock

3. Full release selector cock

4. First service cutout cock

Independent Brake Valve Handle

Rotair Valve

i. Miscellaneous Controls

Dome Light switches

Bell ringer valve

Horn valve cords

j. Train Phone Controls and Equipment

Loudspeaker

Handset with "PUSH TO TALK" Button

Calling Signal Lever

Communication Channel (Frequency Selector) Lever

Power Contactor Control Switch

Volume Control Knobs (2)

Noise Suppressor Control Knobs (2)

3. CONTROLS AT FIREMAN'S POSITION (See Illustrations 3 and 4)

Heater Switch and Rheostat

Defroster Switch and Rheostat

Hood Light Switch

Classification Light Switch

Number Light Switch

Windshield Wiper Control Valve

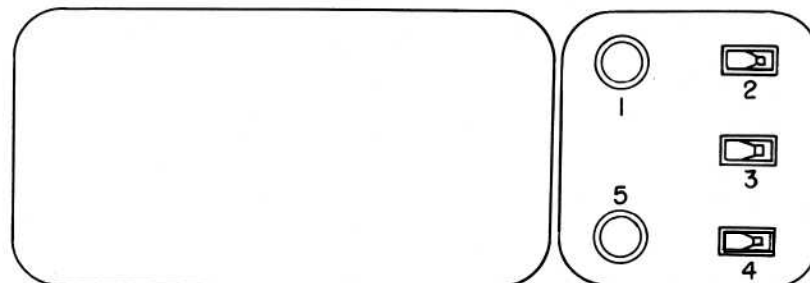

1. Defroster Switch and Rheostat

2. Hood Light Switch

3. Classification Light Switch

4. Number Light Switch

5. Heater Switch and Rheostat



Illus. 4 Control Panel—Fireman's Position

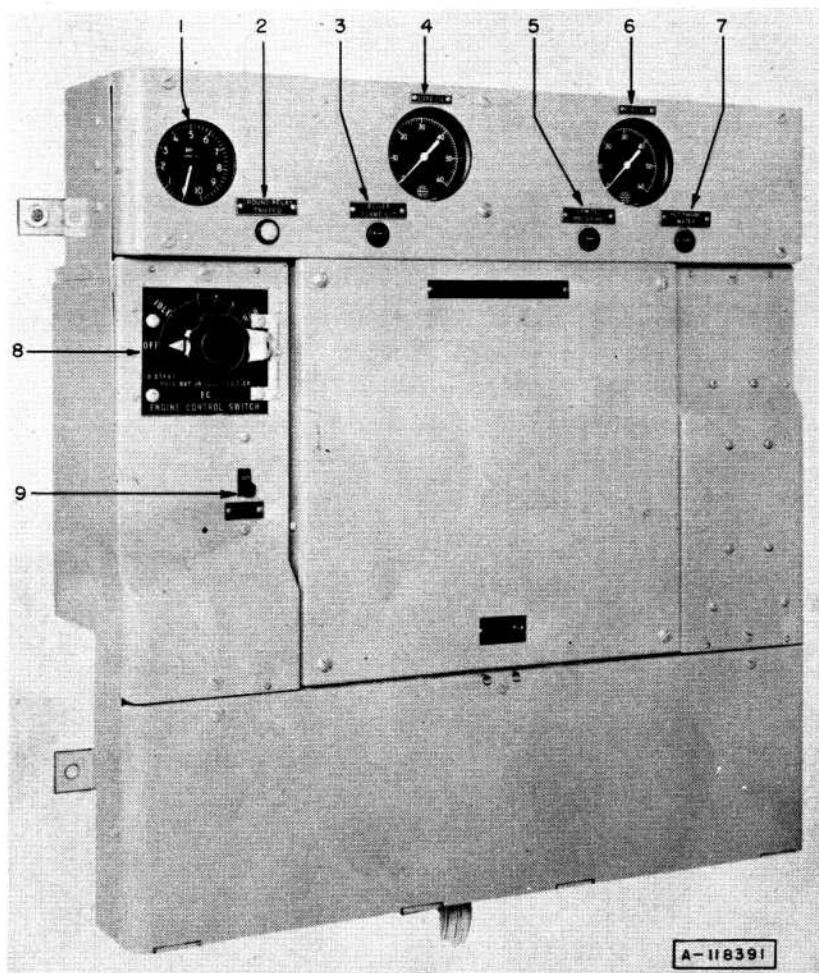

1. Engine Tachometer
2. Ground Relay Tripped Indicating Light (white)
3. Boiler Flame Out Indicating Light (blue)—not used
4. Lube Oil Pressure Gage
5. Low Oil Pressure Indicating Light (yellow)
6. Fuel Oil Pressure Gage
7. Hot Engine Indicating Light (red)
8. Engine Control Switch
9. Fuel Pump Switch

Illus. 5 Engine Control Panel

4. **CIRCUIT BREAKER IN NOSE OF CAB**
Heater and Defroster Circuit Breaker
Fire Alarm Circuit Breaker
5. **CONTROLS IN ENGINE ROOM**
 - a. Controls on Engine
Power Plant Regulator (located at pump end of engine on right side of locomotive)
Fuel Injection Pump Cutout (located on fuel control rod inside injection nozzle compartment, one on each side of each cylinder)
Emergency Stop Push Button
Overspeed Governor Reset Lever
Fuel Rack Indicator (above power plant regulator)
 - b. Switches, Gages and Instruments on Engine Control Panel (Illustration 5), located at right side of locomotive opposite engine
Fuel Pump Switch
Engine Control Switch
Engine Tachometer
Lube Oil Pressure Gage
Fuel Oil Pressure Gage
 - c. Indicating Lights on Engine Control Panel (top of panel)
Ground Relay Tripped (White)
Low Lube Oil Pressure (Yellow)
Hot Engine (Red)
 - d. Automatic Switches on Engine Control Panel (behind lower cover)
Regulator Oil Pressure Switch (GOP)
Engine Water Temperature Switch (WTS)
Engine Oil Temperature Switch (OTS)
 - e. Switches and Circuit Breakers on Control Compartment Panel, (located at generator end of engine room) (See Illustration 6)
Control Compartment Light Switch
Engine Room Light Switches (Two)
Light Circuit Breakers (All Lights) (Two)
Voltage Regulating Relay Circuit Breaker
Battery Voltmeter
Control Circuit Breaker (negative)
Control Circuit Breaker (positive)
Auxiliary Generator Circuit Breaker
Radiator Fan Speed Control Switch

f. Switches and Circuit Breaker on Right Side of Control Compartment, Behind Engineer's Position (See Illustration 7)

Governor Circuit Breaker
Engine Room Aisle Light Switch
Step Light Switch

g. Switches and Gage Inside Control Compartment (See Illustration 7)

Ground Relay Cutout Switch (inside lower left hand section)
Ground Relay Reset Push Button (GR) (projecting through left frame of relay equipment)
Motor Cutout Switch (inside upper left hand section)
Control Air Pressure Gage (inside upper right hand section)

6. OTHER ENGINE ROOM GAGES AND CONTROLS

Main Battery Switch (located at right side of air compressor)
Engine Cooling Water Temperature Gage
Engine Lubricating Oil Level Bayonet Gage (Control side of engine)
Engine Lubricating Oil Temperature Gage
Engine Cooling Water Level Gages
Fuel Tank Level Gage (under engine compartment deck)
Air Compressor Discharge Pressure Gage (left side of air compressor)
Air Compressor Governor
Air Compressor Lube Oil Level Bayonet Gage
Air Compressor Lube Oil Pressure Gage
Power Servo-Motors for Radiator Shutter Operation
Fan Motor Control Switches
Generator Air Recirculating Damper
3-Way Aisle Light Switch (left side of rear door)
Emergency Fuel Trip Handle (opposite generator shroud, right side)

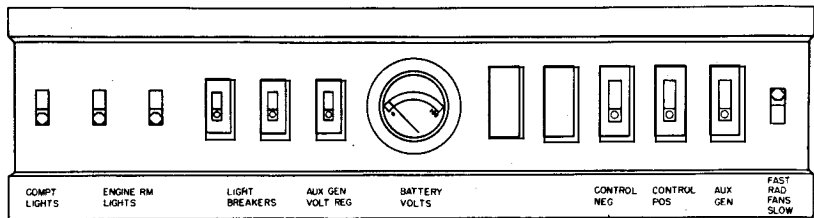

Illus. 6 Compartment Control Panel

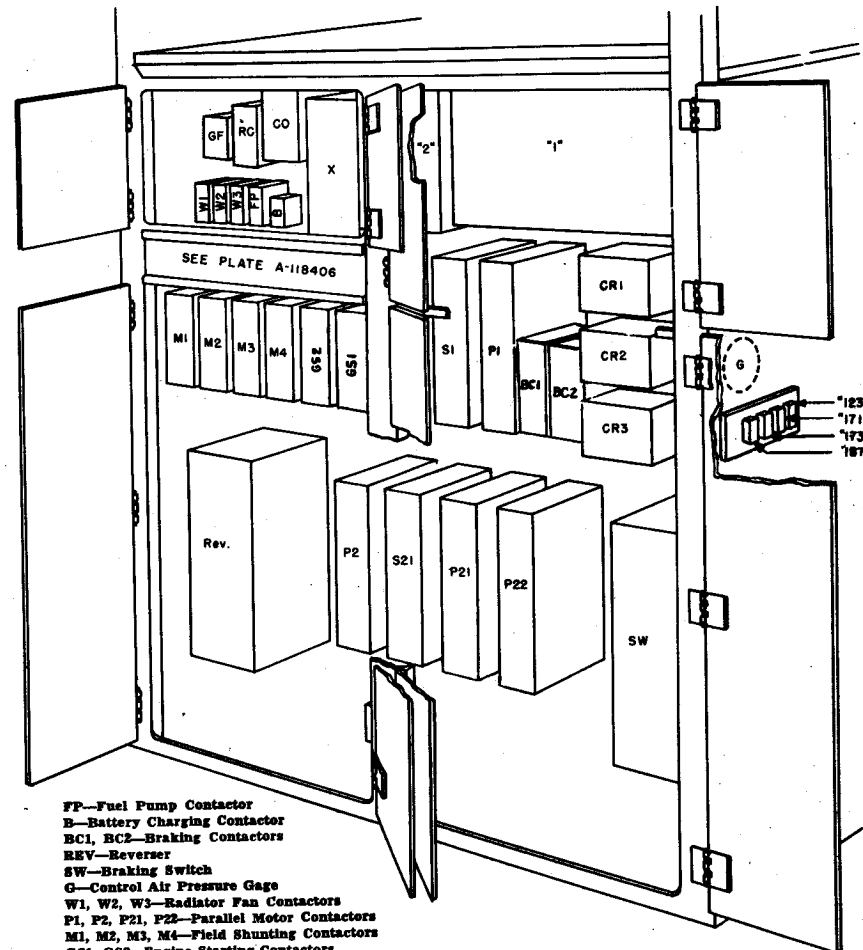

FP—Fuel Pump Contactor
B—Battery Charging Contactor
BC1, BC2—Braking Contactors
REV—Reverser
SW—Braking Switch
G—Control Air Pressure Gage
W1, W2, W3—Radiator Fan Contactors
P1, P2, P21, P22—Parallel Motor Contactors
M1, M2, M3, M4—Field Shunting Contactors
G81, G82—Engine Starting Contactors
CR1, CR2, CR3—Transition Relay Equipment
S1, S21—Series Motor Contactors
"187"—Fuel Pump Circuit Breaker ("B" Unit only)
"173"—Step Light Switch ("A" Unit only)
"171"—Engine Room Aisle Light Switch ("A" Unit only)
"123"—Governor Circuit Breaker (all Units)

GF—Generator Field Contactor
RC—Reverse Current Relay
CO—Motor Cutout Switch
X—Excitation Regulator
"2"—Excitation Panel
"1"—Relay Equipment

PLATE A-122826

Illus. 7 Control Compartment Arrangement

c. Control Stand Operating Handles and Indicating Equipment

1. GENERAL

The control stand in each "A" unit has three operating handles. These three handles are mechanically interlocked. Before attempting to move the locomotive, the engineman must be thoroughly familiar with their movements. Also, he must be familiar with their relations to the load-braking indicator and speed-transition indicator.

2. OPERATING HANDLES (See Illustration 8)

Reverse Handle has three positions, "FORWARD" - "OFF" - "REVERSE." This handle controls direction of locomotive movement.

Selector Handle has an "OFF" position, four power operation positions (1, 2, 3, and 4) to the left of "OFF" and a dynamic braking control range to the right of "OFF."

Throttle Handle has nine positions, "IDLE" and eight running notches controlling engine speed and excitation.

3. MECHANICAL INTERLOCKING BETWEEN OPERATING HANDLES

a. The reverse handle cannot be moved from "FORWARD" to "REVERSE" (or removed from the control stand) unless the selector handle is in "OFF" or "1" and the throttle handle is in "IDLE."

b. The selector handle cannot be moved from "1" to "OFF" unless the throttle handle is in "IDLE." It can be moved through the power operation positions (1, 2, 3, and 4) with the throttle handle in any position **except** that it cannot be moved from "2" to "3" or "3" to "2" with the throttle handle in positions 7 and 8—the throttle **must be reduced** to position 6 or below for these transitions.

c. The selector handle cannot be advanced beyond "1" unless the reverse handle is in "FORWARD" or "REVERSE." It can be moved from "OFF" to "1" or "1" to "OFF" with the reverse handle in any position or the reverse handle removed.

d. The selector handle cannot be moved into the dynamic braking range **except** when the throttle is in "IDLE" and the reverse handle is in "FORWARD."

e. The throttle handle cannot be moved from "IDLE" unless the selector handle is in "1" or above. It cannot be advanced with the reverse handle removed but can be advanced with the reverse handle inserted and in "FORWARD," "REVERSE" or "OFF."

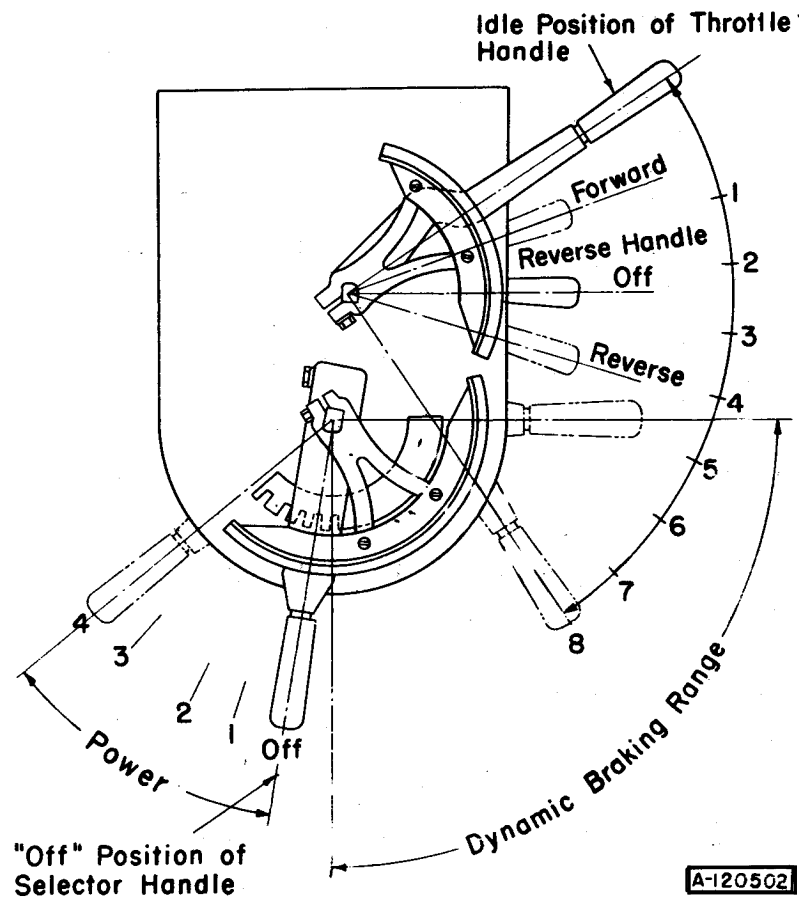

Illus. 8 Reverse, Selector and Throttle Handle Positions

f. The throttle handle is equipped with an "automotoneer" which prevents the throttle from being opened more than one notch at a time. To advance the throttle from notch to notch, the handle must be pushed toward "IDLE" slightly and then pulled out to the next notch. This movement toward "IDLE" should be slight, sufficient only to cause a latch to click in the control stand. If the throttle is retarded too much during this handling, the latch will again engage the handle in the original notch and the throttle will not advance to the next position. When closing the throttle, there is no restriction and the full movement can be made without pausing at each notch.

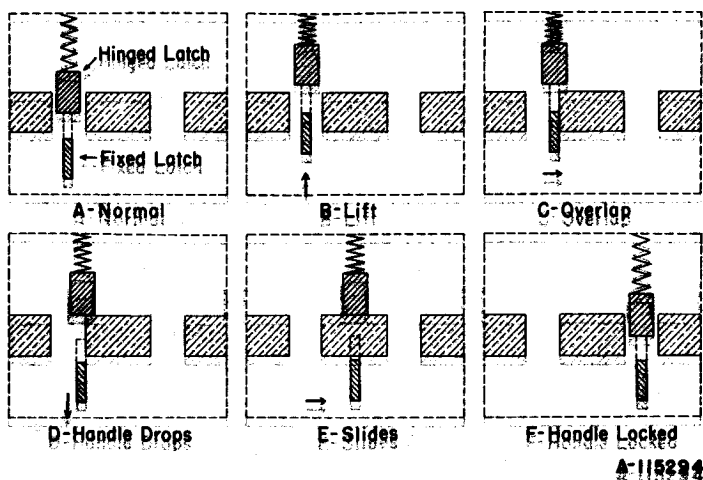

Illus. 9 Selector Handle Latching

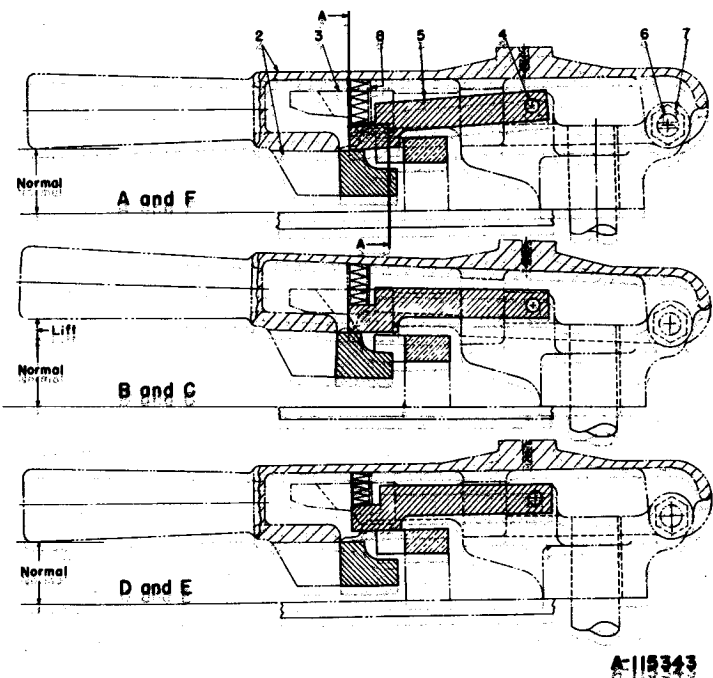

Illus. 10 Selector Handle Latching—Side View

4. SELECTOR HANDLE LATCHING

Free travel of the selector handle out of each power position is prevented by two latches built into the handle. A definite sequence of motions is required in moving the handle from one position to another in each direction. This prevents the handle being accidentally moved while locomotive is under power.

To pass from one position to another, raise the handle, move it in desired direction until the lower latch strikes the far side of the notch. This is a very slight movement. Drop handle and move toward the next position. When the next position is reached, the upper latch will drop into the notch, stop the movement and lock the handle.

When making transition from position 2 to 3, or from position 3 to 2, it will be necessary to have throttle handle in notch 6 or lower, since interlocking will prevent movement of selector handle when throttle handle is in notches 7 or 8.

5. SELECTOR HANDLE MOVEMENT FOR DYNAMIC BRAKING.

For application of the dynamic brake, the selector handle is lifted from its latched position in "OFF" and moved toward the engineer's position. A slight movement of the handle in this direction brings it to the "B" position where it will latch in a manner similar to that in the power positions. The letter "B" will appear in the selector handle window. The movement of the handle to "B" establishes the dynamic braking circuits. For application of the dynamic brake, the handle is disengaged from the "B" notch and moved to the right and forward. The dynamic brake effect increases as the handle is moved further from the "B" position and the handle can be moved freely throughout its travel. However, the range of movement used is determined by the reading of the pointer of the load-braking indicator. See Section 104.

d. Transition

As the locomotive speed increases or decreases, the electrical connections of the traction motors are changed to maintain the maximum drawbar pull and power output of the locomotive. This change from one connection to another is called "TRANSITION." The locomotives covered by this manual are equipped with "automatic transition" described below. On locomotives using "manual transition," the changes are made by manual movement of the selector handle.

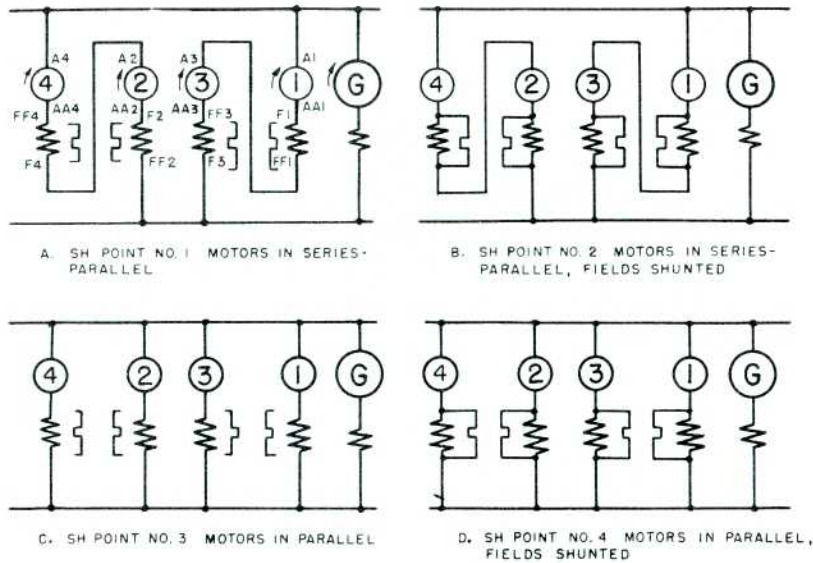

A-120382

Illus. 11 Traction Motor Connections

1. AUTOMATIC TRANSITION

With this device, the selector handle is placed in position 4 when starting the train. The changes in traction motor connections then take place automatically at predetermined locomotive speeds without action by the engineer.

With 70/17 gearing (70 tooth axle gear—17 tooth traction motor pinion) and 42" wheels, the automatic transition will function at the following speeds (with new wheels).

- No. 1 to No. 2—17 MPH
- No. 2 to No. 3—22 MPH
- No. 3 to No. 4—43 MPH

2. SUPERVISORY CONTROL OF AUTOMATIC TRANSITION

The range of the automatic transition can be limited by placing the selector handle in any of the four power positions. The automatic transition will then not advance beyond the traction motor circuit corresponding to the position of the selector handle, regardless of locomotive speed. For instance, if the selector handle is placed in 2, the transition from series-parallel with motor fields shunted (No. 2) to parallel (No. 3) will not take place when the speed rises above 22 MPH.

When the selector handle is so used to limit the automatic transition range, maximum locomotive power is obtained at speeds up to 17 MPH with the handle in 1, 22 MPH with the handle in 2 and 43 MPH with the handle in 3.

3. TRACTION MOTOR CONNECTIONS

The traction motor circuits set up are listed below. The number of each circuit corresponds to the selector handle position for that traction motor hookup, when manual transition is used.

- No. 1—Series-Parallel
- No. 2—Series-Parallel with motor fields shunted
- No. 3—Parallel
- No. 4—Parallel with motor fields shunted

The schematic diagram of the four circuits is shown in Illustration 11.

4. SPEED-TRANSITION INDICATOR (See Illustration 12)

This instrument is located second from left side of instrument panel. Its purpose is to indicate locomotive speed and transition positions. It has two scales.

- a. Speed Scale—calibrated in miles per hour.
- b. Transition Scale—divided into four numbered zones 1, 2, 3 and 4, which indicate the motor connections (transitions) at various speeds. See **Locomotive Operation, Sect. 104.**

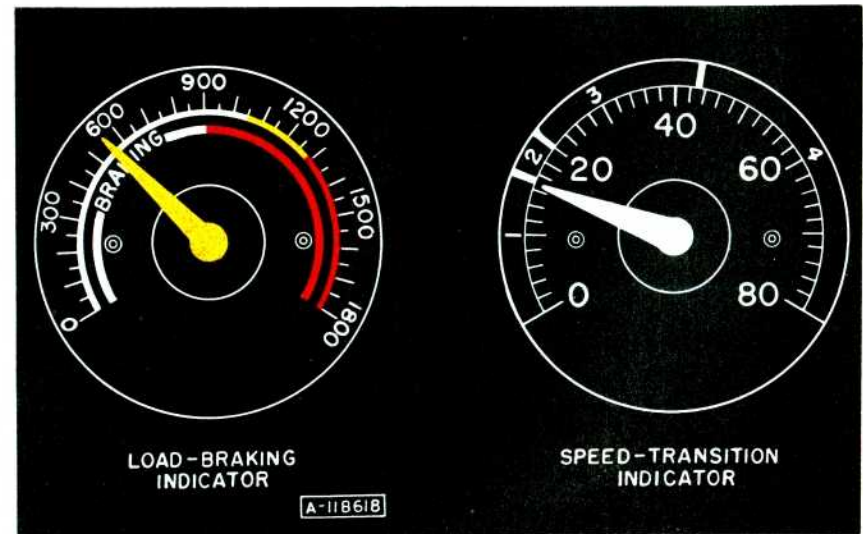

Illus. 12 Load-Braking Indicator and Speed-Transition Indicator

5. LOAD-BRAKING INDICATOR (See Illustration 12)

This instrument is located at the left hand side of instrument panel, and is essentially an ammeter with two scale bands.

a. Load Scale Band

Red zone at high current end of scale. Operation in this zone is permitted only while starting and accelerating train.

Yellow zone at the left of the red in which operation is permissible for a period of time not exceeding 1½ hours.

White zone at the left of yellow. Operation in this zone is allowable for continuous operation.

Note: Operation in the YELLOW zone for an accumulated time exceeding 10% of the total operating time will result in shortened motor life and higher maintenance costs.

b. Dynamic Braking Scale (inner band)

Used only with dynamic braking.

e. Dynamic Braking

When the dynamic brake is in operation, the train pushes against the locomotive. The wheels then drive the traction motors instead of the motors driving the wheels. By a change of electrical connections, accomplished by moving the selector handle to the "B" position, the traction motors are converted into generators. The motors, as generators, produce electricity which is dissipated in resistor grids located near the top of each locomotive unit body. As torque is required to turn the motors when they are so generating, the wheels resist turning and thus hold the locomotive back. The locomotive, in turn, resists the push of the train at the drawbar and exerts a retarding or braking force on the train.

In converting the traction motors to generators, the armatures are disconnected from the field windings. The armatures, driven by the wheels, produce the electricity. The field windings of the four motors of each unit are connected in series and energized by the output of the main generator, driven by the engine at idling speed.

Movement of the selector handle, through the dynamic braking range, varies the output of each of the main generators. Thus, movement of the selector hand in turn varies the current passing through the traction motor fields and consequently controls the amount of electricity generated by the traction motors at any given locomotive speed. As the torque required to drive the traction motors depends on the current being generated, the braking effect in-

creases or decreases as the traction motors are made to produce more or less electricity. Thus movement of the selector handle controls the dynamic braking force of the locomotive.

The pointer on the inner scale of the **load braking indicator** indicates the current being generated by the No. 1 traction motor during dynamic braking. The selector handle must be so manipulated that the pointer remains in the white zone on the dial. If the dynamic brake is so applied that the pointer moves out of the white zone, the white **warning light** at the right side of the instrument panel will come on. See **Section 104** for instructions on handling of the dynamic brake.

Section 104

LOCOMOTIVE OPERATION

a. Preliminary Operations

1. IN TRAILING "A" UNIT

Check to see that the following switches and handles are in proper position as indicated:

a. **Control** and **cab signal** circuit breakers and **generator field switch** "OFF" at control stand.

b. **Throttle** in "IDLE" and **selector** handle in "OFF" position.

c. **Reverse** handle removed.

d. **Reverse** and **air brake** handles in storage compartment provided for that purpose.

e. **Rotair** valve in "LAP" position.

f. **Fire alarm warning** and **Cab heater—defroster—gage light** circuit breakers "OFF" in hood compartment.

g. **Train control** circuit breakers "OFF" at control panel in rear of unit near the motor generator.

h. **Fuel pump** circuit breaker "OFF".

i. **Main battery** switch closed.

j. **Governor** circuit breaker "ON".

k. **Control negative, control positive, auxiliary generator, auxiliary generator voltage regulator** and **light** circuit breakers "ON" at control compartment panel.

l. Set **radiator fan speed control** switch in proper position. Snap up to "FAST" if the outside temperature is above 75 to 80 degrees, down to "SLOW" if the air temperature is lower.

m. Open the doors of the control compartment. Make sure the **traction motor cutout** switch is in the "ALL IN" position, (handle vertical). See that the **ground relay** switch is closed. Press **ground relay reset button** to insure that **ground relay** is set. Check **control air pressure** (70 pounds) on gage at right of cabinet.

n. See that all safeguards are in place and see that all foreign material such as waste, rags, tools, etc. have been collected and removed from all shafts, openings, moving parts and electrical compartments.

o. Check the water level of the engine cooling system and the lubricating oil levels of the engine and air compressor.

p. Check that air compressor governor cock is open.

q. Make sure that air compressor governor cutout cock is "OPEN".

2. ON TRAILING "B" UNITS

- a. See that **independent air brake** is set on "RUNNING" position and sealed in that position.
- b. See that **hostler switch** is in "OFF" position and is latched in that position.
- c. Repeat steps h. through p. as outlined for trailing "A" unit.

3. ON LEADING "A" UNIT

- a. See that **reverse handle** is inserted and in "OFF" position, throttle in "IDLE", selector handle in "OFF". Insert the brake handles.
- b. Set K-2 Rotair valve in "FRGHT" or "PASS", depending whether or not the "controlled emergency" feature is desired.
- c. See that **control circuit breaker** and **generator field switch** on control stand are "OFF".
- d. Snap "ON" **fuel pump** and **cab signal circuit breakers** on control stand.
- e. Snap "ON" **fire alarm warning** and **cab heater—defroster—gage light circuit breakers** in hood compartment.
- f. Snap "ON" **train control circuit breakers** in rear of unit near the motor generator.
- g. Repeat steps i. through p. as outlined for trailing "A" unit.

b. Starting Engines and Putting Engines "On the Line."

1. STARTING ENGINES

- a. Check the engine **overspeed governor reset lever** on the engine above the power plant regulator. Reset, if necessary, by pulling the lever in the direction indicated on the name plate to the limit of its travel.
- b. Snap on **fuel pump switch** on engine control panel and note that fuel pump runs and fuel oil pressure builds up to between 12 and 18 lbs. on gage of engine control panel.
- c. Turn **engine control switch** to "IDLE." Hesitate momentarily. Then pull out switch knob to "START" position.
- d. Hold knob in "START" position until engine fires and speeds up sufficiently to extinguish the **low oil pressure** indicator. At this point, the oil pressure should be approximately 8 lb.

NOTE: The engine should start turning promptly when the engine control switch knob is pulled out and firing should occur within a few revolutions.

- e. If engine does not fire, release knob and turn to "OFF" position. Repeat engine start. **Do not attempt to start engine repeatedly as this will run down the storage batteries.**

2. AFTER ENGINE IS RUNNING

After engine is running see that:

- a. **Lubricating oil pressure** is at least 8 lb.
- b. **Air compressor** and **traction motor blowers** are operating normally.
- c. **Radiator shutters** are in normal position.
- d. There are no leaks in piping systems.
- e. Proper voltage is being obtained on **battery voltmeter**.
- f. Repeat items a. through e. above for engines in other units.

3. PUTTING ENGINE "ON THE LINE"

- a. To put engine "on the line," turn **engine control switch** (one position at a time) to "RUN". It comes under control of the throttle handle as soon as the switch is moved above "IDLE" position.
- b. Repeat operations for other units.

4. FINAL CHECK

Make a final check on operation and **lube oil** and **fuel oil pressure** gages.

c. Preparations for Moving Locomotive

1. LEADING "A" UNIT

- a. If necessary, turn **gage light control switch** on control stand to "ON" and hold clockwise against the return spring pressure until gage panel lights come on; then release pressure.
- b. See that **air compressors** are maintaining main reservoir air pressure at 130-140 lb.
- c. See that **air brake equipment** is properly set up on all units.
- d. Release **hand brakes**.
- e. Make necessary air brake tests. **Place foot on safety control pedal before releasing locomotive brakes.**
- f. Test operation of **air horns** and **locomotive bell** on leading unit.
- g. Test operation of **sanders**.
- h. Close **generator field switch** and **control circuit breaker** on control stand panel.

d. Pumping Up Train Line

If main reservoir pressure cannot be maintained while charging trainline, proceed as follows:

1. Close **control** breaker at control stand on leading "A" unit, leaving **generator field** switch "OFF".
2. Move reverser handle to "OFF" position.
3. Place **selector** handle in position 1.
4. Advance the **throttle** handle to notch 4 (**one notch at a time**).

Caution

Do not advance the throttle handle beyond notch 4 for this operation.

Never pump air with reverse handle in "FORWARD" or "REVERSE" position.

e. Starting Train

1. With the **throttle** handle in "IDLE", place the **selector** handle in position 4 for automatic transition operation.
2. Move **reverse** handle to "FORWARD" or "REVERSE" as required by train movement.

Caution

Never move reverse handle from one position to another unless locomotive is at a standstill; otherwise damage to equipment will result.

3. When ready to start, release air brakes. Wait until train brakes are fully released; then place **throttle** in notch 1. If the locomotive does not move, advance **throttle** one notch at a time until it does. **Damage to traction motors will occur if they remain stationary with power applied for prolonged periods.** Power required to start train may move **load-braking indicator** pointer into the red band. As soon as the locomotive moves, the **throttle** may be controlled as train operation requires.

Advance **throttle** a notch at a time to increase speed, going into red zone only as necessary to accelerate train.

4. USING SAND

Use sand whenever necessary to avoid slipping of driving wheels. If wheel slipping is continuous, notch off **throttle** until slipping stops.

5. NOTCHING OFF

- a. Notching off should, if possible, be done **a notch at a time** for smooth operation.
- b. When shutting off power, **throttle** may be closed regardless of position of **selector** handle.

6. MAXIMUM SPEED

If the locomotive overspeed warning whistle sounds, reduce speed, or make a 15 lb. forestalling brake application, within six seconds. Lack of such action will cause an emergency air brake application to be initiated and the power output of the locomotive will be cut off. The speed of the diesel engines will drop to "idle."

f. Forestalling Automatic Transition Changes

Under certain operating conditions, the locomotive speed may be such that the automatic transition will change back and forth with any slight changes in the grade. The action will be noted by the behavior of the **load-braking indicator** pointer which will alternately show different readings.

This operation of the automatic transition produces unnecessary wear on the contactors and automatic transition equipment. The **selector** handle should be moved to the position corresponding to the **lower** of the two positions between which transition is taking place. For instance, if the **speed transition indicator pointer** is approximately on the line between Zone 2 and Zone 3, place the **selector** handle in **Position 2**.

g. Special Instruction—Operation by Manual Transition

If it is necessary to operate the locomotive by manual transition for any reason, the following instructions will apply.

1. STARTING A TRAIN

Place **selector** handle in **No. 1 position**. Start train by the same throttle handling and other operations as given for automatic transition.

2. ACCELERATING TO SPEED

As the train speed increases, watch the **speed—transition indicator**. **When the pointer moves from Zone 1 to Zone 2, shift the selector handle to position 2.** As the speed further increases, and the pointer reaches the line between Zone 2 and Zone 3, **reduce throttle to Notch 6** and shift selector handle to position 3. **Return**

throttle to notch 8 after making shift. Shift selector handle to position 4 when the speed-transition indicator crosses the line into Zone 4. The throttle need not be reduced.

3. TRAIN SPEED DECREASING DUE TO GRADE

As the train speed falls due to grade or other conditions, make **selector** handle shifts in reverse order. **Reduce throttle to notch 6** when shifting from No. 3 to No. 2.

Caution

The selector handle must be kept in a numbered position which is the same as or lower than the zone indicated by the speed-transition indicator pointer. The selector handle must never be allowed to remain in a position higher than the speed transition indicator reading. This is particularly important when the locomotive speed drops due to grade conditions. If the action is neglected, serious damage to the traction motors will be the result.

h. Stopping or Reducing Locomotive Speed

1. AIR BRAKING WITH POWER APPLIED

If power is left on the locomotive to keep slack out when applying brakes for slow down, use reduced **throttle** while applying brakes. **Throttle must be in "IDLE" when locomotive stops.**

2. THROTTLE IN IDLE FOR STOPS

Be certain that the **throttle** is in "IDLE" position before train comes to a stop and during the stop. **Continued application of power to traction motors even for a short period when stationary is very likely to result in serious damage.**

3. VISUAL INSPECTION AT STOPS

If time permits during stops, make visual inspection of under part of locomotive to detect any signs of trouble. Watch especially for **hot journals, hot motor axle bearings or hot armature bearings.**

Note any fuel oil, lube oil, water, air or steam leaks. Also check for loose or dragging parts.

i. Dynamic Braking

1. ESTABLISHING DYNAMIC BRAKING

a. When the dynamic brake is to be used, close the throttle to "IDLE" and return the selector handle to "OFF" if it is in a power

operation position. Disengage the selector handle latching mechanism from the "OFF" position and move the lever toward the engineer's position until it latches in the "B" position. This movement should be made rapidly, in the same manner as when changing from one power position to another. It is not necessary to "feel" for the "B" position. Note that this movement of the selector handle can be made only when the throttle is in "IDLE" and the reverse handle in "FORWARD."

b. The load-braking indicator pointer should show a slight movement as dynamic braking is established. Disengage the selector handle and move it forward very **SLOWLY** until the pointer moves up to approximately 100 amperes. The braking effort obtained at this point will be enough to bunch the slack, and the selector handle should not be advanced any further until the slack is bunched.

2. USING THE DYNAMIC BRAKE

a. When the slack is bunched, move the handle slowly toward the right. As the handle is moved, the reading of the load-braking indicator will rise and the dynamic brake effect will increase. If maximum braking is desired, continue the movement of the handle until the pointer of the load-braking indicator reaches the upper limit of the white zone. **Do not allow the pointer to go into the red zone.**

b. If the braking effect, at maximum application, is sufficient to slow down the train, the pointer will fall back as the train speed drops. To maintain maximum braking effort, continue the movement of the handle to keep the pointer near the upper end of the white zone as the train speed decreases. If a steady speed is desired rather than a slowdown, ease off on the dynamic brake by moving the handle back toward "OFF" until the train speed steadies at the required miles per hour. To hold this speed, the handle can be moved slightly forward to retard the train or back to speed it up.

c. On heavier grades, the effect of the dynamic brake may be insufficient to hold the train. With maximum dynamic brake application (pointer at the upper limit of the white zone) the train speed will increase. As the train speed rises, the load braking indicator pointer will go up on the scale and tend to move into the red area. Keep moving the handle back to hold the pointer in the white area. When the train speed comes up to the desired limit, make an air brake application to check the train. Do not change the position of the selector handle. After the speed has been reduced sufficiently, release the air and allow the dynamic brake to hold the train while the brake pipe is being recharged. When the air brakes apply, the

pointer will drop back. After release of the air, the train will again gain speed, assuming the grade conditions are the same. This will cause the pointer to rise toward the top of the white area. When the pointer reaches the limit of the white zone, the speed will again be at the desired limit and another air brake application should be made. This method of handling will maintain a nearly constant speed if light air brake applications are made which will reduce the speed very slightly. Actually, the effect of a light air application will first show as a movement of the load-indicator pointer before it is noticeable on the speed-transition indicator as a drop in speed. Thus, if the air is released as soon as the load braking indicator begins to fall back, the speed indicator will remain practically steady. After some practice in judging the frequency and amount of air applications, an engineer will be able to descend a grade at a constant maximum allowable speed which will materially lower the running time. A similar procedure should be used when the grade includes stretches where the speed is restricted because of curves, track conditions, etc. By use of heavier air applications, the speed can be reduced to meet the restriction. After passing a restricted area, release the air and allow the train to come up to the normal speed for the grade where the pointer will again reach the top of the white area. This method will accomplish smooth train handling and, in some respects, act as a graduated release after slowdowns.

WARNING—Keep the locomotive brakes released when automatic air brake applications are made while the dynamic brake is in use. Neglect of this precaution may cause wheel slide and flat spots.

Severe conditions of grade and tonnage may be encountered which will make the continuous use of full dynamic brake desirable. Under these circumstances, advance the selector handle during air brake applications to keep the pointer at the limit of the white zone. While the train is gaining speed after release of the air, ease off the selector handle to prevent the pointer from moving up into the red zone. This handling requires more manipulation and attention by the engineer and is seldom necessary.

d. If the dynamic brake is over-applied, the white "Dynamic Brake Warning" indicator, on the instrument panel, will light. If these warnings occur, ease off the dynamic brake or make an air brake application to reduce the train speed. In either case, continue the action until the light goes out.

The actuating point of the alarm system is normally set so that the light will operate when the load-braking indicating pointer goes approximately 30 amperes into the red zone. However, under

no circumstances should the warning signals be disregarded—even if they should occur when the load indicator pointer is in the white zone.

A "dynamic brake interlock" is provided to prevent the locomotive brakes from applying when service applications are made while the dynamic brake is in use. If, however, service applications are initiated by safety control or train control functions while the dynamic brake is in operation, the interlock will nullify the dynamic brake and allow the locomotive brakes to apply. Also, the locomotive brakes can be applied at any time by use of the independent brake valve, irrespective of the dynamic brake. This may cause wheel slide, however, and must not be done except at very low speeds as covered below.

e. The dynamic brake is not intended for use in bringing a train to a stop. The effect of the dynamic brake diminishes rapidly as the speed drops below approximately 19 M.P.H. At 10 miles per hour, the dynamic braking effect is 50% of that at 19 M.P.H., at 5 M.P.H. approximately 25%, and zero as the stop is approached. However, if the distance available for the stop is sufficient and it is desired to avoid an automatic air brake application for some particular reason, the train may be slowed down gradually with the dynamic brake. When the speed decreases to approximately 8 M.P.H., move the selector handle toward the "OFF" position, making a light application of the independent air brake which will prevent "run out" as the dynamic brake is released. After the selector handle is in "OFF," increase the independent brake application to make the final stop.

WARNING: Extreme care must be used, under the above circumstances, to avoid wheel slide. Apply the independent air only when the dynamic braking becomes insufficient to prevent run out. Never apply dynamic and independent air brakes together at speeds over 8 M.P.H.

3. RELEASING THE DYNAMIC BRAKE

a. Release of the dynamic brake should be made gradually to avoid run-out in the train under certain conditions. Keep in mind that the dynamic brake has somewhat the same effect as a powerful independent air brake and be governed accordingly.

b. When releasing the dynamic brake, a light application of independent air may be made as the handle is moved from "B" to "OFF" and the independent then slowly released. This action should be taken where grade conditions are such that the locomotive will tend to "run away" from the train when the dynamic brake is released.

j. Stopping Engines

1. SHUTTING DOWN ENGINE

- a. Move **engine control** switch to "IDLE" position.
- b. Before stopping any engine (except for emergencies), wait until water temperature drops to approximately 165° F.
- c. Stop the engine by turning **engine control** switch to "OFF".
- d. Snap "OFF" **fuel pump** switch on engine panel.

k. Emergencies

1. STOPPING ALL ENGINES FROM LEADING UNIT

- a. In case of an emergency requiring the immediate simultaneous stopping of all power plants, push **engine stop button** on control stand panel. This button should only be used for this purpose.

NOTE: After stopping the engines in this manner, open the **control circuit breaker** in the leading "A" unit cab before starting the engines. If the breaker is left closed, the **engine control** switches in all units must be moved to "OFF" simultaneously before any engine can be started.

- b. Snap "OFF" the fuel pump circuit breaker in the leading "A" unit to stop all fuel pumps.

2. REMOVING ENGINE FROM LINE

An engine in any unit can be removed from the line, with the locomotive running at any speed on any throttle notch, by turning the **engine control** switch to "IDLE".

3. RETURNING ENGINE TO LINE

Any engine can be put back on the line, after being in "IDLE", by turning the **ENGINE CONTROL** switch to "RUN", one position at a time. A slight pause is desirable at each position to allow engine to come up to speed under load, in case the throttle is open. As the engine comes up to speed, it will assume its share of load for each position on the **engine control** switch.

4. SHUTTING DOWN ANY ENGINE WITH TRAIN IN MOTION

Any engine can be shut down in emergencies by the stop push button above the overspeed reset lever on the control side of the engine. Normally, an engine is stopped by turning the **engine control** switch to "OFF." After shutting down an engine, snap the **fuel pump** switch to "OFF" on the engine control panel.

5. STARTING THE ENGINE WITH TRAIN IN MOTION

- a. Follow procedure outlined in par. b. on page 2 of this section.

- b. When dynamic braking is in use, return selector handle to "OFF" position while engine is being put "ON THE LINE."

6. SHUTTING OFF ALL FUEL IN CASE OF FIRE

- a. Snap "OFF" **fuel pump** circuit breaker on control stand.
- b. Shut down all engines by pushing **emergency engine stop** button at engineman's position.
- c. Pull nearest **emergency fuel cutout trip** handle on each unit.
- d. Snap "OFF" **fuel pump** switch on each engine control panel.

l. Operating Precautions

1. REVERSING

Bring locomotive to a dead stop before moving reverse handle for opposite locomotive movement. Applying power in reverse direction, before locomotive stops, may cause serious damage to traction motors.

2. MAXIMUM SPEED

Never operate locomotive over maximum speed.

3. OPERATING THROUGH WATER

Do not operate locomotive through water more than 4 inches over top of rail, and then at a speed not exceeding 3 MPH. After passing through water, place **generator field** switch in "OFF", move **reverser** handle to "OFF", and place **selector** handle in position 1. Open **throttle** to notch 4 or below for about ten minutes. This will allow the water to be dried off traction motors.

4. PASSING OVER RAILROAD CROSSING

When approaching a railroad crossing, **throttle** should be moved back below Notch 3 and kept in that position until all locomotive units have passed over the crossing. This will minimize the possibility of traction motor flashovers because of brushes being jolted off the commutator.

m. Changing Operating Cabs

1. KEEPING ENGINE RUNNING

Just before it is time to change operating cabs, arrange to have the **fuel pump** circuit breaker snapped "ON" in the new leading cab. This will keep the engines running when the **fuel pump** circuit breaker is snapped "OFF" as in 2. below. **Never operate with more**

than one fuel pump breaker closed, except for a few seconds when changing ends.

2. NEW TRAILING CAB

- a. **Selector** handle must be in "OFF" position, throttle in "IDLE" and **reverse** handle moved to "OFF" and removed.
- b. Make a full service automatic brake application, return the brake valve to lap and close the double heading cock.
- c. Move the K-2 Rotair valve to "LAP" position.
- d. Move the automatic brake valve handle to "RUNNING" position and remove it.
- e. Remove the independent brake valve handle in "RELEASE" position.
- f. Close the signal line supply cock (where used).
- g. Snap "OFF" **generator field** switch and **control, fuel pump, cab signal, cab heater—defroster—gage light, fire alarm warning and train control** circuit breakers. Make sure the **fuel pump** circuit breaker is "ON" in the new leading cab (as in 1.) before opening the trailing cab fuel pump breaker.

3. NEW LEADING CAB

- a. Snap "ON" **cab signal, cab heater—defroster—gage light, fire alarm warning and train control** circuit breakers.
- b. Open the signal line supply cock (where used).
- c. Apply the automatic brake valve and independent brake valve handles.
- d. Move the **K-2 Rotair** valve to "FRGT" or "PASS", depending on class of service.
- e. Apply reverse and air brake handles, leaving reverse handle in "OFF" position.
- f. Move the independent brake valve to "FULL APPLICATION" position and open the double heading cock.
- g. Make air brake test.
- h. Locomotive is now ready to move in accordance with instructions on "Moving Locomotive."

n. Leaving Locomotive

1. LEAVING LOCOMOTIVE TEMPORARILY

- a. Leave engine idling if absence is to be for a short time.
- b. Place **throttle** handle in "IDLE" position.
- c. Place **selector** handle in "OFF" position.

- d. Place **reverse** handle in "OFF" position and remove handle.
- e. Open **generator** field switch.
- f. Set independent brake.

NOTE: Control breaker may also be opened as a safety precaution.

2. LEAVING LOCOMOTIVE FOR LAYOVER

- a. Shut down diesel engines and snap "OFF" **fuel pump** switches on all engine control panels.
- b. Protect against freezing, if necessary. (See "Freezing Weather Precautions.")
- c. Remove **reverse handle** from control stand and place in storage box.
- d. Snap "OFF" **control** circuit breaker and **generator field** switch at control stand.
- e. Set **hand brake** in each unit.
- f. **Open main battery switch in each unit.**

o. Rerailing

1. GENERAL

In some cases, a locomotive can be rerailed under its own power, if one pair of wheels or one truck only is off the track, by using a rerailing frog. The power must be cut off the derailed wheels while the power is applied to those remaining on the rails. If one pair of power wheels is off, turn the motor cutout switch to the proper position to cut out the motor driving these wheels. If one truck is off, turn the motor cutout switch to the number corresponding to one of the motors in that truck. Cut out the second motor in the truck by blocking open the proper "P" contactor in the control compartment. Block open the P2 contactor to cut out No. 1 motor, P21 for No. 2, P1 for No. 3 or P22 for No. 4. The brakes should be set about 10 lb. of air, and the throttle handle notched up cautiously so that locomotive will move very slowly, and will not slip back when throttle is moved to "IDLE". The throttle must not be notched up for more than a few seconds at a time.

p. Towing Locomotive Dead in Train

1. Move **reverse** handle to "OFF" position and remove from control stand.
2. **Throttle** handle in each "A" unit must be in "IDLE" and **selector** handle in "OFF" position.
3. Air brakes must be set up as follows:
 - a. Close double heading cock on the automatic brake valve.
 - b. Remove handles from both brake valves.

c. Place K-2 Rotair valve in "PASS" position.

d. Dead engine cock handle, on the D-24 control valve, must be moved toward the "DEAD" position. Provision is made for sealing if necessary.

NOTE: In dead heading a "B" unit, move the dead engine cock handle on the D-24 control valve of that unit toward the "DEAD" position.

4. PROTECT AGAINST FREEZING IF NECESSARY (See "Freezing Weather Precautions").

5. OPEN MAIN BATTERY SWITCH IF POSSIBLE

If **battery switch** must be closed for operation of essential auxiliaries, **open all possible circuit breakers and switches**. This will keep battery load to a minimum.

q. Periodic Inspection on Road

1. GENERAL

a. Observation of each power plant on the road need only be made as operating schedules permit, unless other instructions are issued by the railroad.

b. However, close observation of the normal running sound of the engine will enable operator to detect any deviation therefrom. Check the following for abnormal operation and if any abnormal conditions are noted, trouble should be found and corrected if possible.

Engine Tachometers

Fuel Oil Pressure Gages

Lube Oil Pressure Gages

Engine Water Temperature Gages

Lube Oil Temperature Gages

2. LUBE OIL PRESSURE

a. Normal lubricating oil pressures with the throttle in notch 8 are 20 lb. to 25 lb. with SAE No. 30 oil, 30 lb. to 35 lb. with SAE No. 40 oil. At idling speed the lubricating oil pressure should be above 8 lb.

b. If the lube oil pressure falls below a safe figure at any engine, the engine will stop and the alarm bells will sound throughout the locomotive. The yellow "LOW OIL PRESSURE" alarm indicators will light in the A unit cabs and on the engine control panels in all units.

When this occurs, turn the engine control switch to "OFF" and snap "OFF" the fuel pump switch at the engine control panel of the stopped engine. Investigate the cause. If the cause is not readily determined, bar the engine over, to make sure it is free, before starting.

WARNING

Never operate a Diesel engine without sufficient lubricating oil or sufficient pressure.

3. FUEL OIL PRESSURE

The **fuel oil pressure** is normally 12 lb. to 18 lb. on gage on the engine control panel. If pressure should vary above or below these limits, report the trouble for correction.

4. BATTERY CHARGING

The **battery voltmeter** pointer should be in the green band between 72 volts and 76 volts.

5. AIR COMPRESSOR GOVERNOR GAGE

The air compressor governor gage reading should be between 125 lb. and 140 lb. on all units, or in accordance with the limits specified by the individual railroad.

6. DIESEL ENGINE ATTENTION ON THE ROAD

a. If any unusual sounds or smells are observed, investigate immediately.

b. **Do not change any power plant regulator, throttle adjustment or setting. Any changes are to be made only by experienced service personnel. Report trouble for correction.**

c. The operating crew is expected to be alert for evidence of failure in any part of the engine, and should investigate and report any such developments. However, no duties or tests, other than routine inspections, are prescribed since the operation of the diesel engine is automatic when once started and placed on the line. Automatic alarms are provided in both the engineman's cab and the engine room to indicate low lubricating oil pressure, high engine cooling water temperature or high lube oil temperature. Low lubricating oil pressure in any unit will stop the engine. High water or oil temperatures will reduce the power output of the unit concerned by 25%.

r. Summary of Operating Precautions

1. In all cases of trouble or abnormal operation take necessary precautions against injury to person or equipment.

2. In case of fires near fuel oil lines or fuel tank, quickly pull nearest emergency fuel cutout handle.

3. In emergencies, all power plants may be shut down simultaneously by pushing **engine stop button** on any control stand panel. Immediately afterward snap "OFF" **fuel pump** circuit breaker on the leading unit. The **engine stop button** will immediately shut down all diesel engines and the **fuel pump circuit breaker** will shut down all **fuel pumps**. If possible, proceed to each engine control panel, open **fuel pump** switch and turn all **engine control** switches to "OFF".

4. If a locomotive or a unit continues to develop power with **throttle** handle in "IDLE", or if throttle handle sticks in a power notch, snap "OFF" **control circuit** breakers and **generator field** switch on control stand panel. If power continues, close control circuit breaker and press **engine stop button** on control stand of leading unit. Afterwards open **fuel pump** circuit breaker.

5. If necessary to pump up a long train, increase air compressor output by moving reverse handle to "OFF". Open **generator field** switch, place **selector handle** in position 1 and notch up on **throttle** handle to notch 4 or below.

6. When towing a unit or a locomotive, the maximum train speed must be governed by the maximum speed of the towed unit or units. Observe precautions for towing as described earlier.

s. Electrical Precautions

1. Watch **battery charging voltmeters** on inspection rounds to see that normal battery charging is taking place.

2. A circuit breaker which trips on overload assumes a position approximately midway between "ON" and "OFF". It must be moved to "OFF" position before it can be reset. If necessary to reset tripped circuit breakers, first make certain that circuit affected is in operating condition. If circuit breakers reopen, remedy the trouble or shut down the affected apparatus.

3. Do not block in contactors, relays or circuit breakers.

4. In case of fires resulting from grounds, short circuits or flash-overs in electric circuits, generators or traction motors, shut down power plant at once. If any insulation continues to burn, use CO-2 type extinguisher in putting out the fire.

5. Observe that **traction motor blowers** are operating at all times when locomotive is under power

t. Operating with One Motor Cut Out

1. To cut out motor 1, on any unit, move throttle handle to "IDLE". Then turn the **motor cutout** switch to "1 CUTOUT" position. When cutting out a motor on one of the trailing units, operation will be usual except for the reduction in available horsepower and starting tractive effort. The horsepower output of the engine will be reduced automatically by the power plant regulator, and each of the motors remaining in operation will be loaded approximately the same as the motors remaining in the other units. If the train cannot be started, the tonnage must be reduced or helper service provided. When motor 1 is cut out on the leading unit, the load-braking indicator, which is connected in No. 1 motor circuit, will not operate and no indication will be obtained.

2. To cut out motors 2, 3, or 4, close **throttle** handle to "IDLE", then turn the **motor cutout** switch to "2, 3, or 4 CUTOUT". Locomotive operation will be the same as when motor 1 is cut out. When operating with motor 2, 3 or 4 cut out on the leading unit, the **load-braking indicator** position at stand-still will be approximately two-thirds of that actually being obtained per motor on each of the trailing units. Care must therefore be used when advancing throttle to prevent slipping the wheels on trailing units.

3. Motors may be cut out without closing the **throttle** of leading unit. Take the affected power plant off the line by turning **engine control** switch on engine control panel to "IDLE". The **motor cutout** switch may then be turned to cut out the desired motor. Put the engine back on the line by turning **engine control** switch from "IDLE" to "RUN" a notch at a time.

u. Operating with One Unit Cut Out

1. If it becomes necessary to unload or stop an engine, turn the **engine control** switch from "RUN" to "IDLE", one position at a time. This will remove the load from that engine. To stop the engine turn the **engine control** switch to "OFF" and open the **fuel pump** switch on control panel.

2. If the engine that is cut out is on the leading unit, no load-braking indicator operation will be shown and the engineman must rely upon his experience to determine if operating equipment is being overloaded. A rider may be stationed in the trailing "A" unit to signal the engineman if overload conditions occur. Regardless of which engine is cut out, be alert for **wheel slipping and overloads**.

v. Diesel Engine Precautions

1. Do not operate with mechanical trouble in any rotating or reciprocating parts of the engine.

2. Report all unusual sounds or actions of any part of diesel engines, diesel engine accessories or electrical equipment. Shut down affected engine if necessary.

3. Keep diesel engines running as continuously as possible, shutting down only on account of trouble or if locomotive is to be inoperative for more than an hour or two.

4. Do not attempt to correct trouble by making adjustments to engine, power plant regulator, temperature or pressure switch or any control device. Trouble should be reported for correction by experienced service specialists.

5. Report any unusual exhaust conditions observed.

6. If trouble occurs during freezing weather and it becomes necessary to shut down any diesel engine, protect the equipment against freezing as described under "Freezing Weather Precautions."

w. Operation with Reduced Diesel Engine Output

1. In case of trouble in the injection system of any one cylinder, operation may be continued after cutting out the particular injection pump affected. In such cases, the demand on the engine is reduced in proportion by the power plant regulator. If a spring breaks in either an injection pump or an injection nozzle, or the tube connecting these parts leaks, cut out the injection pump and continue to operate until the trouble can be remedied.

2. A pump or nozzle is cut out by disengaging the plunger guide on the fuel control rod from the control rack of the injection pump.

x. Freezing Weather Precautions

During freezing weather, certain precautions must be taken to safeguard the locomotive equipment. Ice formation may hinder the operation of the radiator shutters. If the locomotive power plant is shut down during freezing weather for any great length of time, drain water systems to "low level" and heat them by use of the Vapor Clarkson Coil Type Heater.

1. RUNNING

a. Engine cooling water temperature must be watched carefully to prevent any possibility of the engine overheating while running with "low level."

b. Recirculate generator air to keep engine room warm by opening damper.

c. In the event that ice forms on the radiator shutters, remove ice at the first opportunity.

d. When operating during freezing weather, the low level water drain valve should be opened and allowed to remain open. Opening of the low level drain valve will drain the water from the expansion tank and will permit the radiators to drain into the lower water tank when the engine is stopped.

2. SHUTDOWNS IN FREEZING WEATHER

If it is necessary to shut down an engine while the locomotive is enroute in freezing weather for any reason, protect it against freezing as follows:

a. See that all radiator shutters are closed.

b. Open the "low level" valve.

c. Open valve 8 (see Fig. 1.).

d. Start the Vapor Clarkson Coil Type Heater by closing the switch on the panel.

e. Open valve 4 to admit hot water to the heating coil in the toilet water tank.

f. In "A" units only, open valve 2 to supply hot water to the cab heaters. Make sure that the control valves are open at the cab heaters to allow circulation through them.

NOTE: If the fire fails to start in the Coil Type Heater when the switch is closed:

1. Make sure Manual Fuel By-Pass Valve is fully closed.

2. Adjust the Fuel Key Metering Valve until the fire starts. Further adjust the valve to obtain best stack conditions.

3. DRAINING

In case the coil type heater is inoperative or not available for any reason, the water systems should be drained by the following procedure:

a. Drain all cooling systems by opening all drain valves provided in piping systems.

b. **Remove: Lower drain plugs** of both exhaust manifold water jackets, adjacent to number 10 cylinder (two).

Drain plugs on the underside of both exhaust "L" water jackets (two).

Drain plug on the water inlet header nameplate (one).

Drain plugs on the bottom of each water pump (two).

- Drain plugs** on the underside of the oil cooler heads (two).
- c. Empty **water treatment device** if used.
 - d. Drain **toilet water tanks**.
 - e. Drain **cab heaters**.

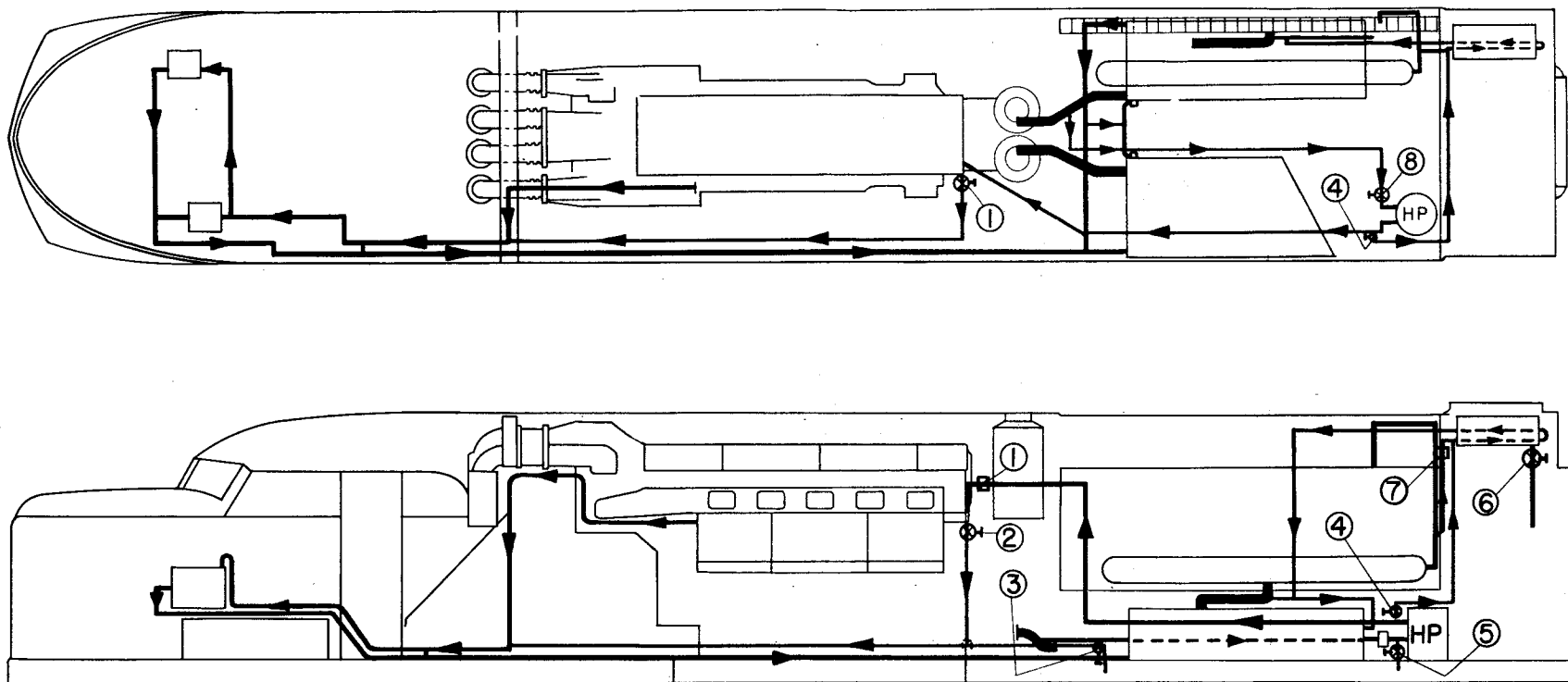

A-1228441

HP Heater and Pump—heats water and provides pressure for system operation

- 1. Check Valve—Gives unidirectional water flow
- 2. Globe Valve—Regulates amount of water flow to the cab heaters ("A" units only)
- 3. Globe Valve—drain valve for system

- 4. Globe Valve—regulates hot water flow to water storage tanks
- 5. Globe Valve—drain valve for system
- 6. Globe Valve—drain valve for water storage tank
- 7. Check Valve—gives unidirectional water flow
- 8. Globe Valve—prevents circulation in system when engine is running

Fig. 1. Standby Heating Arrangement

Operating Instructions for TRAIN COMMUNICATION EQUIPMENT

Operation

To turn the train communication equipment "ON" and "OFF", operate the toggle switch on the control station panel. Should the pilot light fail to light when the switch is in the "ON" position, a talking test should be made with another trainphone unit to determine whether or not the system is in serviceable condition. The light may be burned out and therefore fail to indicate properly.

Selector lever "S" is the channel selector and is moved left to "H" or right to "L" to select the channel desired for transmission or reception on the handset. The handset must be removed from the hook and the "S" lever moved fully to the right or left position to select the desired channel. This lever is automatically locked in position for the channel selected for conversation on the handset but it returns to its normal neutral position when the handset is replaced on the hook. When the selector lever is locked in either channel position, do not attempt to transfer it to the other channel unless the handset hook switch is depressed to release the magnetic latch holding the lever in position. Mechanical abuse may damage the latch mechanism and prevent it from properly locking the selector lever.

To Talk

Remove handset from its hook and hold it to the side of the head in the same manner as a regular telephone. Move the selector lever "S" to "L" or "H" to connect the handset in the proper channel for talking. When talking, it is necessary to hold down the "PRESS-TO-TALK" button. After talking, this button should be released immediately to set up the equipment for reception. After the channel selection is made, the loud speaker is automatically connected to the opposite channel from the one to which the selector is moved. This provides for emergency call reception through the loud speaker.

Adjustments

Adjustments on the control panel include two "volume controls," one for the handset, the other for the loud speaker. Turning in a clockwise direction will increase the volume of sound from the handset receiver or the loud speaker. There are also two noise suppressor controls, one for each "L" and "H" channel.

Volume Controls

The handset and loud speaker volume controls should be adjusted to a point where the volume is sufficient for good reception but

not too loud to cause distortion or annoyance. Extremely loud talk is of no benefit in transmission; in fact, it serves only to distort the conversation.

Noise Suppressors

Noise suppressor controls on the "H" and "L" channels are for the purpose of adjusting the train communication receivers to their best operating condition.

November, 1947.

