

# SD40-2

## **OPERATOR'S MANUAL**

SERVICE DEPARTMENT



# SD40-2

## OPERATOR'S MANUAL

5th Edition

March 1978

SERVICE DEPARTMENT



Electro-Motive Division  
Of General Motors

La Grange, Illinois 60525

## **NOTICE**

The purpose of this manual is to act as a guide in the operation of the locomotive and its equipment. The information was compiled for a typical locomotive with basic equipment and frequently requested extras. The equipment selected for coverage was chosen as representative and not intended as an indication of availability or use on a particular unit or order. When special extra equipment is involved, consult specific drawings or instructions as provided by the railroad.

The information contained in this manual is based on data available when released for printing.

Minor differences encountered in equipment are due to changes made after the manual was sent to press. These changes will be covered in subsequent editions of this manual.

## **INTRODUCTION**

This manual has been prepared to serve as a guide to railroad personnel engaged in the operation of the 3000 horsepower General Motors Model SD40-2 turbocharged diesel-electric locomotive.

The contents are divided into four sections as follows:

1. General Description - Provides general description of principal equipment components.
2. Cab Controls - Explains functions of cab control equipment used in operating the locomotive.
3. Operation - Outlines procedures for operation of the locomotive.
4. Trouble Shooting - Describes cause, location and correction of possible troubles occurring during operation.

A block of page numbers is allocated to each section, Section I starting with page 1-1, Section 2 with 2-1, and the others following in this manner. Figures are identified by section and sequence. For example: Fig. 2-3 is the third figure used in Section 2.

To obtain the most benefit from this manual, it is recommended that the sections be read in the sequence in which they appear.

Information pertaining to maintenance, adjustment, and testing is contained in the Locomotive Service Manual. Instructions for testing and maintenance of individual locomotive components are a part of the standard EMD Maintenance Instruction bulletin series.

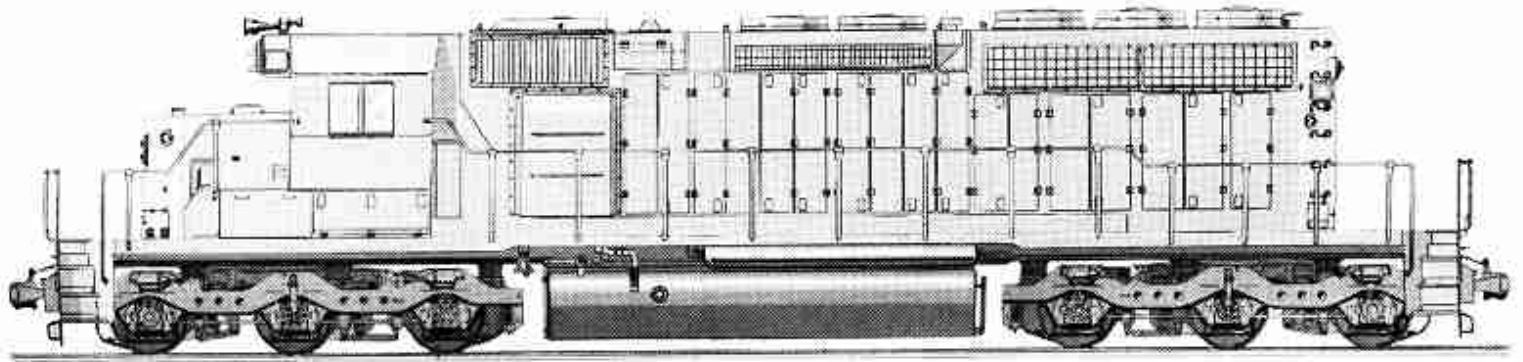

20773

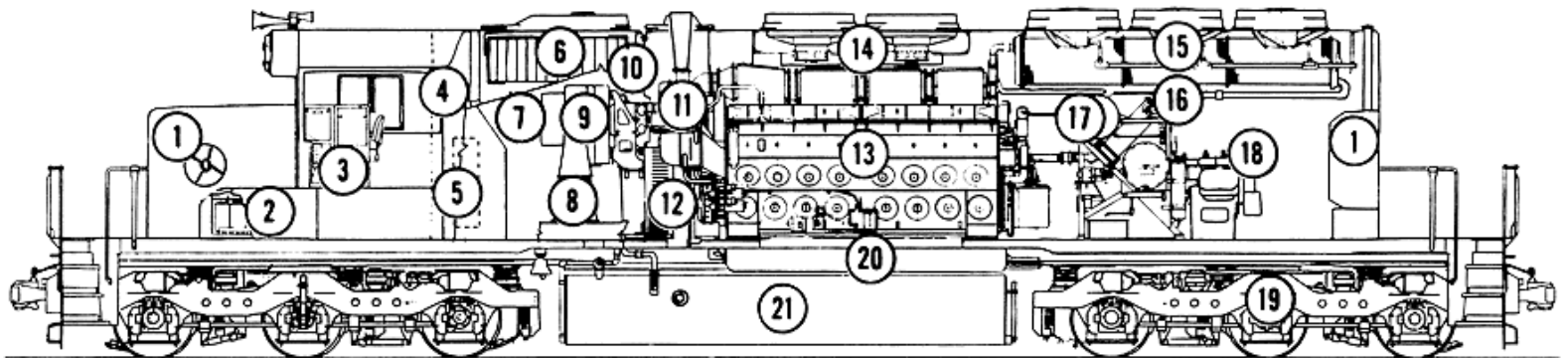

22967

1.	Sand Box	8.	Traction Motor Blower	15.	Radiator Cooling Fans
2.	Battery	9.	Generator Blower	16.	Radiators
3.	Control Stand	10.	Auxiliary Generator	17.	Equipment Rack
4.	Electrical Cabinet	11.	Turbocharger	18.	Air Compressor
5.	Electrical Cabinet Air Filter	12.	Main Generator	19.	Truck
6.	Inertial Filter	13.	Diesel Engine 16-645E3	20.	Main Air Reservoir
7.	Engine Air Filter	14.	Dynamic Brake Blowers	21.	Fuel Tank

## GENERAL DATA

Model Designation	SD40-2
Locomotive Type . . . . .	(C-C) 0660
Locomotive Horsepower . . . . .	3000
Diesel Engine	
Model . . . . .	645E3
Type . . . . .	Turbocharged
Number Of Cylinders . . . . .	16
Cylinder Arrangement . . . . .	45 deg "V"
Cylinder Bore And Stroke . . . . .	9-1/16" x 10"
Operating Principle . . . . .	2 Stroke Cycle, Turbocharged, Unit Injection, Water Cooled
Full Speed . . . . .	904 RPM
Idle Speed	
Normal . . . . .	318 RPM
Low . . . . .	255 RPM
Main Generator Model . . . . .	AR10 - D14
Traction Alternator (Rectified Output) . . . . .	AR10
Number Of Poles . . . . .	10
Nominal Voltage (DC) . . . . .	600
Frequency (At 900 RPM) . . . . .	75 cps
Companion Alternator . . . . .	D14
Nominal Voltage (AC) . . . . .	215
Number Of Poles . . . . .	16
Frequency (At 900 RPM) . . . . .	120 cps
Auxiliary Generator Voltage (DC)	74
Rating	
Basic	10 KW
Extra	18 or 24 KW
Traction Motors	
Model	D77
Number	6
Type	DC, Series Wound Axle Hung
Driving Wheels	
Number	6 Pair
Diameter	40"
Tread	Tapered

### Maximum Speed Options With Gear Ratio

Gear Ratio	Top Speed* MPH	Minimum Continuous MPH
62:15	65	11.1
61:16	70	12.0
60:17	76	13.0
59:18	82	14.0

\*Based on rated RPM of traction motors.

Air Compressor	
Type . . . . .	2 Stage
Number Of Cylinders . . . . .	3
Capacity (At 900 RPM) . . . . .	254 Cu. Ft./Min.
Air Compresgor Cooling . . . . .	Water
Lube Oil Capacity . . . . .	10-1/2 Gal.
Storage Battery	
Number Of Cells . . . . .	32
Voltage . . . . .	64
Rating (8 Hour) . . . . .	420 Amp Hr.
Supplies	
Lubricating Oil Capacity . . . . .	243 Gal.
With Deep Sump Oil Pan . . . . .	395 Gal.
Cooling Water Capacity	275 Gal.
Fuel Capacity (Basic) . . . . .	3200 Gal.
With Extra Capacity . . . . .	4000 Gal.
Sand . . . . .	56 Cu. Ft.
Air Brakes . . . . .	Type 26L
Approximate Weight On Rails . . . . .	368,000 lbs.
Weight On Drivers . . . . .	100%
Major Dimensions	
Width Over Cab Sheeting . . . . .	10' 0"
Width Over Basic Arm Rests . . . . .	10' 4"
Height, Top Of Rail To Top Of Cooling Fan Guards . . . . .	15' 7-3/16"
Distance Between Coupler Faces . . . . .	68' 10"
Distance, Pulling Face Of Coupler To Bolster Centerline	12' 8"
Distance Between Bolster Centers . . . . .	43' 6"
Minimum Curve Negotiation Capability	
193 Ft. Radius -- 30 deg Curve - Single Unit With Single Shoe Or Clasp Brakes.	
230 Ft. Radius - 25 deg Curve -- (No End Footboards) -- Two Units Coupled.	
359 Ft. Radius - 16 deg Curve - Unit Coupled To Standard 50 Ft. Box Car.	

# TABLE OF CONTENTS

	<u>Page</u>
INTRODUCTION	
GENERAL DATA	
<u>SECTION I -- GENERAL DESCRIPTION</u>	
Introduction . . . . .	1-1
How The Locomotive Operates . . . . .	1-2
<u>SECTION 2 - ENGINE STARTING AND CAB CONTROLS</u>	
Introduction . . . . .	2-1
Engine Starting Controls . . . . .	2-1
Switch And Fuse Panel . . . . .	2-3
Circuit Breaker Panel . . . . .	2-7
Circuit Breakers Required On For Locomotive Operation . . . . .	2-7
Miscellaneous Circuit Breakers . . . . .	2-11
Engine Control Panel . . . . .	2-13
Locomotive Control Stand . . . . .	2-24
Mechanical Interlocks On The Controller . . . . .	2-29
Air Brake Equipment . . . . .	2-30
Brake Equipment Positions . . . . .	2-35
<u>SECTION 3 - OPERATION</u>	
Introduction . . . . .	3-1
Preparation For Service . . . . .	3-1
Lead Unit Cab Inspection . . . . .	3-2
Engineroom Inspection . . . . .	3-4
Engine Inspection . . . . .	3-4
Starting The Diesel Engine	3-5
Trailing Unit Cab Inspection	3-9
Starting Trailing Unit Diesel Engines . . . . .	3-10
Placing Units On The Line . . . . .	3-11
Precautions Before Moving Locomotive . . . . .	3-11
Handling Light Locomotive . . . . .	3-12
Draining Air Reservoirs And Strainers . . . . .	3-12
Engine Air Box Drain . . . . .	3-14
Remote Traction Motor Cutout Switch . . . . .	3-14
Coupling Locomotive Units Together . . . . .	3-15
Coupling Locomotive Units Together For Dynamic Braking In Mixed Consists . . . . .	3-15
Coupling Locomotive To Train . . . . .	3-16
Pumping Up Air . . . . .	3-16
Brake Pipe Leakage Test . . . . .	3-17
Starting A Train . . . . .	3-17
Accelerating A Train . . . . .	3-19
Air Braking With Power . . . . .	3-20
Operating Over Rail Crossing . . . . .	3-21
Running Through Water . . . . .	3-21
Wheel Slip Correction . . . . .	3-21

Wheel Slip Light . . . . .	3-22
Lock Wheel Light . . . . .	3-23
Locomotive Speed Limit . . . . .	3-23
Mixed Gear Ratio Operation . . . . .	3-24
Dynamic Braking . . . . .	3-24
Dynamic Brake Wheel Slip Control . . . . .	3-28
Double Heading . . . . .	3-29
Operation In Helper Service . . . . .	3-29
Isolating A Unit . . . . .	3-30
Changing Operating Ends . . . . .	3-30
On End Being Cut Out . . . . .	3-30
On End Being Cut In . . . . .	3-31
Stopping Engine . . . . .	3-32
Freezing Weather Precautions . . . . .	3-33
Draining The Cooling System . . . . .	3-34
Towing Locomotive In Train . . . . .	3-37
Leaving Locomotive Unattended . . . . .	3-39

SECTION 4 - TROUBLE SHOOTING

Introduction . . . . .	4-1
------------------------	-----



# SECTION 1

## GENERAL DESCRIPTION

### INTRODUCTION

The General Motors Model SD40-2 locomotive, illustrated in the introduction, is equipped with a turbocharged diesel engine that delivers 3000 horsepower to the main generator for tractive purposes. This power is then distributed to the traction motors, each of which is directly geared to a pair of driving wheels.

The basic locomotive is arranged and equipped so that the short hood or cab end is considered the front or forward part of the unit. However, the locomotive operates equally well in either direction, and on special order controls may be arranged so that the long hood end is forward, or dual controls may be provided.

The locomotive may consist of one or more individual units, each of which is a completely functional power plant. When coupled together for multiple unit operation, all can be simultaneously controlled from a single set of controls located in the cab of the lead unit. This is accomplished through jumper cables connected between the units.

The general arrangement of equipment used on the locomotive is also shown in the introduction. Each of the more important equipment components is numbered and identified in this illustration.

On special order, the locomotive can be equipped with a steam generator for use in passenger service. The fuel tank is divided into a combination fuel tank and water tank and the gear ratio at the traction motor pinion will generally be suitable for high speed operation.

Operating instructions are the same, except for those operations relating to the steam generator. Instructions for operation of the steam generator are provided by the manufacturer of that equipment.

### HOW THE LOCOMOTIVE OPERATES

1. The fuel pump is driven by an electric motor which, for fuel priming, uses current from the storage battery. Once the engine is started and running, the fuel pump motor uses current directly from the auxiliary generator. The fuel pump transfers fuel from the fuel tank under the locomotive to the engine injectors.
2. The diesel engine is started by means of two cranking motors that engage the flywheel ring gear when starting current is applied. The storage battery supplies electric current to engage the starting pinions and rotate the cranking motors.
3. When the engine is running, it supplies mechanical power through shafts and couplings to directly drive three electrical generators, the air compressor, motor and generator blowers, and engine mounted lube oil and cooling water pumps.
4. The auxiliary generator charges the storage battery and supplies low voltage direct current for the control and lighting circuits. The companion alternating current generator furnishes power to the static exciter, various transducers, the radiator cooling fans, and the inertial separator blower motor. The main traction alternator supplies high voltage AC to a power rectifier assembly which then delivers high voltage DC to the traction motors for locomotive pulling power.
5. By means of the cab controls, low voltage circuits are established to actuate the engine governor and the switchgear in electrical cabinets. This switchgear controls generator excitation and distribution of power.
6. Traction motors are located under the locomotive. Each traction motor is directly geared to an axle and pair of driving wheels. These motors are located in two trucks which support the locomotive weight and distribute it to the driving wheels.

7. The throttle electrically controls speed and power by actuating a governor mounted on the engine and by tying the response of the locomotive power control system to throttle position. The main generator converts the engine's mechanical power to electrical power, which is then distributed to the traction motors through circuits established by the various switchgear components in the electrical cabinet.
8. At locomotive start the throttle controls electrical devices that provide rapid power response at a level consistent with smoothly controlled starting.
9. If the locomotive is equipped for performance control, either basically or on special order, electrical devices operating within traction motor capabilities control power at an optimum level. This is done to achieve the desired minimum continuous speed capability at full power and the desired short time power rating. The load regulator, however, remains the main power controlling device, and through most of the operating range of the locomotive maintains power output at the specific level called for by throttle position.
10. The air compressor maintains reservoir air pressure to be used primarily for the air brakes. The air brakes are controlled by the operator through suitable equipment in the cab.
11. Except for manual operation of the cab controls, the locomotive operation is controlled automatically by the excitation and power control system. Various alarms and safety devices will alert the operator should any operating difficulties occur.
12. The excitation and power control system consists mainly of electronic components, most of which are mounted on plug-in circuit modules located in the electrical cabinet. Generally, each circuit module performs a specific function such as initiating application of sand to the rails during a wheel slip.

**CAUTION:** Do not disengage any circuit modules or operate any test switches during locomotive operation.

Do not disengage the VR module unless the diesel engine is completely stopped.

## SECTION 2

### ENGINE STARTING AND CAB CONTROLS

#### INTRODUCTION

A switch for fuel priming and engine cranking is located at the equipment rack in the engineroom. All other basic control equipment used during locomotive operation is at four locations within the cab.

1. Switch And Fuse Panel
2. Circuit Breaker Panel
3. Engine Control Panel
4. Locomotive Control Stand

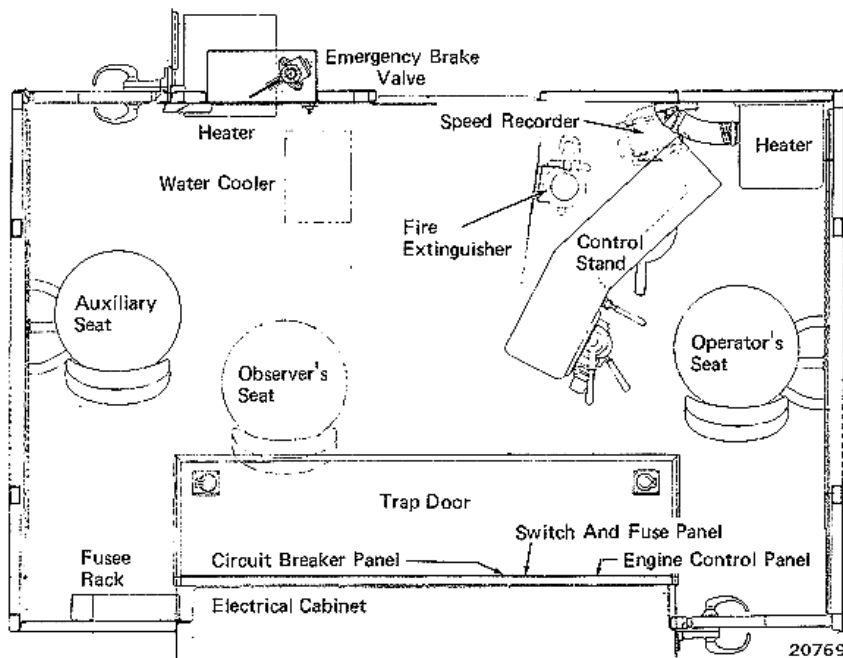

**Cab Arrangement**

#### ENGINE STARTING CONTROLS, Fig. 2-1

##### Fuel Prime And Engine Start Switch

This switch, located on the equipment rack in the engineroom, is a three-position rotary switch used for fuel priming and engine starting. Before attempting to start the diesel engine, the isolation switch in the locomotive cab must be placed in the START position. The rotary switch must then be placed in the FUEL PRIME position and held there for 10 to 15 seconds to operate the fuel pump. The injector rack manual control lever must then be positioned and the rotary switch placed in the ENGINE START position and held (for no longer than 20 seconds) until the engine starts.

##### CAUTION:

The main generator field, the AC control, the auxiliary generator, and the auxiliary generator field circuit breakers must be closed during engine starting or there will be danger of damage to the starting motors if the switch is held too long in

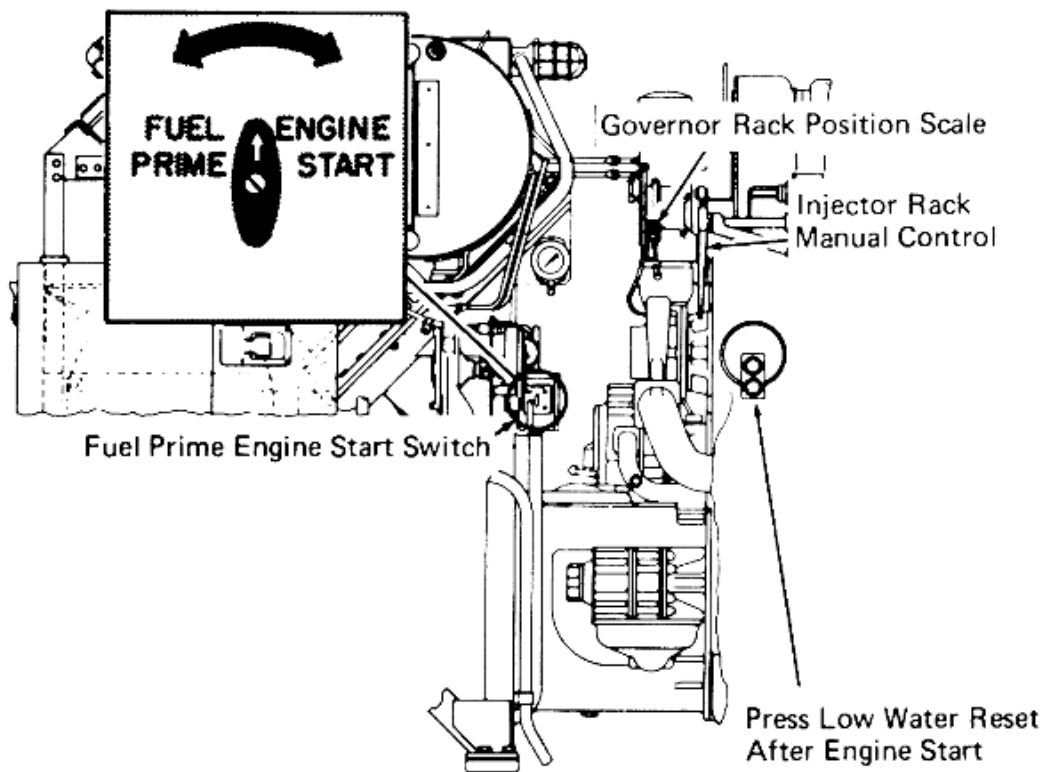

### **Injector Rack Manual Control Lever**

This engine mounted hand operated lever operates the injector racks. It is used to position the injector racks during engine cranking, thereby providing an immediate supply of fuel to the cylinders.

### **Low Water Reset Pushbutton**

Check the low water reset button within 50 seconds after engine start. The low water detector will often trip during engine starting, especially on starting after filling a completely drained system. It may also trip after starting a cold engine or one that has had cooling system pressure released. The detector should be reset soon after the engine starts and is idling, or else the engine will shut down after a time delay established by the engine governor.

### **NOTE:**

If the detector is difficult to reset after engine start, position the injector rack manual control lever to increase engine speed for a short time, then press the reset button. Do not advance the lever to increase engine speed until lube oil pressure is confirmed. The reset button on some detectors will not latch in when the engine is shut down. If such a condition exists, the detector will probably function correctly if it can be reset after engine start.

## SWITCH AND FUSE PANEL, Fig. 2-2

This panel is located within the electrical cabinet that forms the rear wall of the locomotive cab. Its position is directly below the engine control panel which is located in the upper left hand corner of the electrical cabinet.

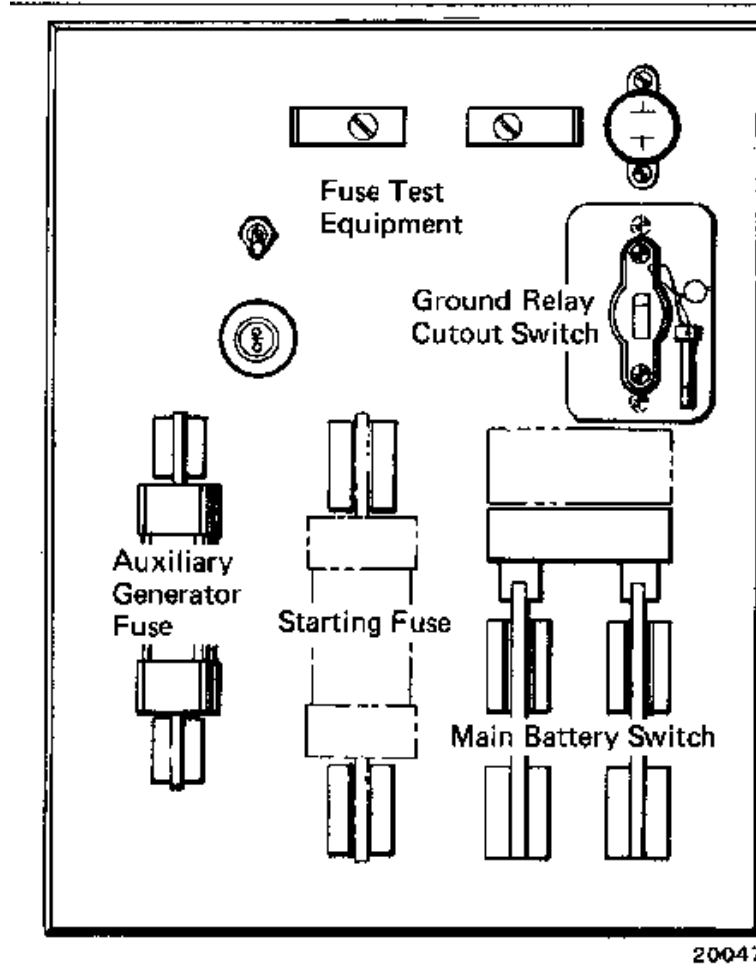

### Fuse Test Equipment

To facilitate the testing of fuses, a pair of fuse test blocks, a test light and a test light toggle switch are installed on the fuse panel. Fuses may be readily tested as follows. First, move the toggle switch to the ON position to make sure the fuse test light is not burned out. Extinguish the light by moving the toggle switch to the OFF position. Place a fuse across the test blocks so that the metal ends of the fuse are in firm contact with the blocks. If the fuse is good, the light will come on. If the fuse is burned out, the light will not come on and a new fuse is required.

It is always advisable to test fuses before installing them in their circuits. Always isolate the circuits in question by opening their switches before changing or replacing fuses.

### NOTE:

There is no D 14 alternator field fuse. If a short occurs in this circuit, auxiliary generator voltage will come down and the machine will not be hanned. A NO POWER/CHRG alarm will be given and traction power will be cut.

The purpose of the ground relay cutout switch is to eliminate the ground protective relay from the locomotive circuits during certain shop maintenance inspections. It **MUST ALWAYS BE KEPT CLOSED** in normal operation. When this multiple pole toggle switch is open, it prevents excitation of the main generator and speedup of the diesel engine in addition to cutting out the ground protective relay.

## **Ground Relay Cutout Switch**

The purpose of the ground relay cutout switch is to eliminate the ground protective relay from the locomotive circuits during certain shop maintenance inspections. It **MUST ALWAYS BE KEPT CLOSED** in normal operation. When this multiple pole toggle switch is open, it prevents excitation of the main generator and speedup of the diesel engine in addition to cutting out the ground protective relay.

## **Auxiliary Generator Fuse**

This fuse connects the auxiliary generator to the low voltage system. It protects against excessive current demands. A 150 ampere fuse is installed for the basic auxiliary generator and a 250 ampere fuse is installed for the heavy duty generator. In the event that the fuse is burned out, it stops auxiliary generator output to the low voltage system and also stops fuel pump operation. An alternator failure (no power) alarm would then occur. The engine will go to idle speed and then stop from lack of fuel.

### **CAUTION:**

The 250 ampere fuse is of the same physical size as the starting fuse. Do not interchange these fuses.

## **Starting Fuse**

The starting fuse is in use only during the period that the diesel engine is actually being started. At this time, battery Current flows through the fuse and starting contactor to the cranking motors.

Although this fuse should be in good condition and always left in place, it has no effect on locomotive operation other than for engine starting. A defective fuse can be detected when attempting to start the engine, since at that time (even though the starting contactors close) the cranking circuit is open.

### **CAUTION:**

The locomotive is equipped with series connected starting motors which require a 400 ampere starting fuse. Certain other model locomotives require an 800 ampere starting fuse. The two fuses are of the same physical size. Observe fuse panel marking. Do not use an incorrectly rated fuse.

## **Main Battery Knife Switch**

The large double-pole single-throw knife switch at the lower portion of the fuse panel is the main battery switch. It is used to connect the battery to the locomotive low voltage system and should be kept closed at all times during operation.

This switch may be opened during certain shop maintenance procedures and in instances where the engine is shut down and the locomotive taken Out of service for an extended layover. This will prevent the battery from being discharged in the event the lights or other low voltage devices are inadvertently left operating during the layover. Particular attention should be given when a notation at the switch cautions against opening the switch immediately after engine shutdown. At least 35 minutes should be allowed following engine shutdown before this switch is opened after load operation at or above throttle position No. 3. That is, cooldown time for the turbocharger bearings can be considered to accumulate below throttle position No. 3 even though the 35 minute timing of the turbocharger auxiliary lube oil pump begins at engine shutdown.

## **74 Volt Receptacle**

A receptacle mounted on the switch and fuse panel makes 74 V DC available for maintenance or test purposes. The voltage is present at the receptacle when the main battery knife switch and the 30 amp. LIGHTS circuit breaker are closed.

## CIRCUIT BREAKER PANEL, Fig. 2-3

This panel is located in the electrical cabinet, directly below the engine control panel. The panel is divided into two sections, one containing those circuit breakers that must be in the ON position to operate the locomotive, and the second section containing those circuit breakers for lights and miscellaneous devices that are used as conditions require.

These circuit breakers can be operated as switches, but will trip when an overload occurs. The generator field circuit breaker will trip to a centered position. After a period for cooling, the breaker must be placed in the full off position before resetting to the on position. Other circuit breakers on the panel trip to the full off position.

## CIRCUIT BREAKERS REQUIRED ON FOR LOCOMOTIVE OPERATION

### Turbo Pump Motor Circuit Breaker

This circuit breaker must be in the ON position to start the engine and operate the turbocharger auxiliary lube oil pump. It must remain in the ON position to provide auxiliary lubrication to the turbocharger at engine start and after the engine is shut down.

### Fuel Pump Motor Circuit Breaker

This three pole circuit breaker protects the fuel pump motor circuit. A fuel filter bypass valve is provided to prevent overloading the fuel pump motor if the fuel filter becomes clogged.

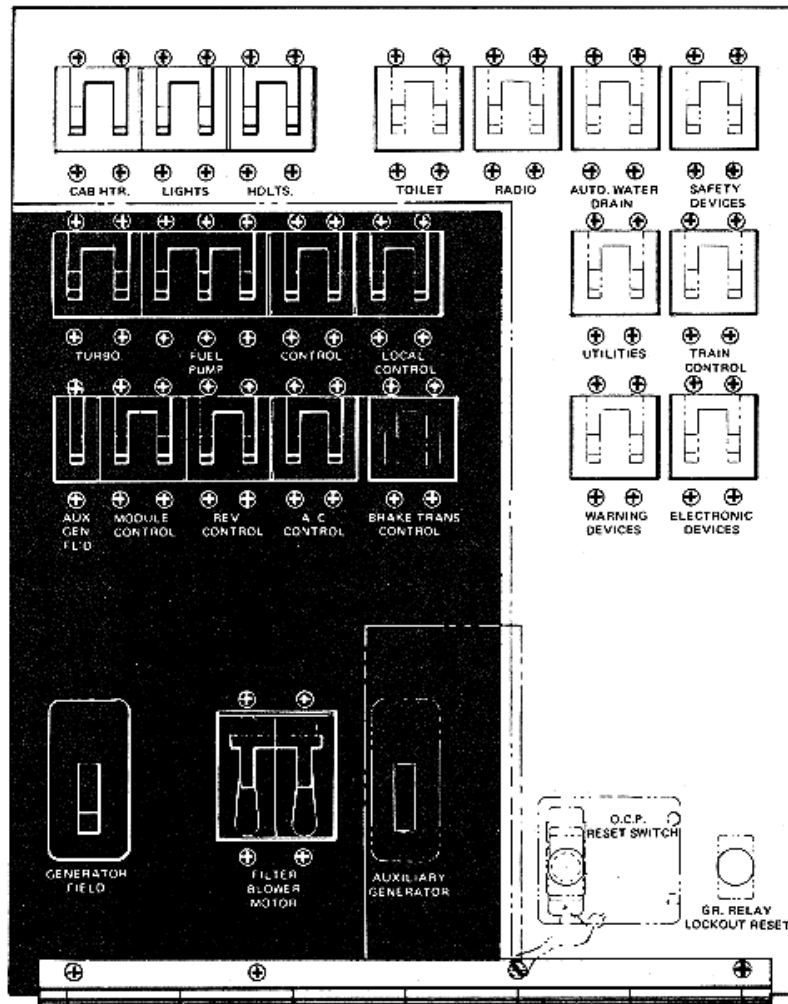

Breakers on black area of panel must be in on position to operate locomotive.

## **Fig. 2-3 - Circuit Breaker Panel**

### **Control Circuit Breaker**

This circuit breaker sets up the fuel pump and control circuits for engine starting. Once the engine is running, power is supplied through this circuit breaker from the auxiliary generator to maintain operating control.

### **Local Control Circuit Breaker**

This circuit breaker establishes "local" power from the auxiliary generator to operate heavy duty switchgear and various control devices.

### **Auxiliary Generator Field Circuit Breaker**

The field excitation circuit of the auxiliary generator is protected by this circuit breaker. In the event that this circuit breaker trips, it stops auxiliary generator output to the low voltage system and also stops fuel pump operation. An alternator failure (no power no battery charge) alarm occurs. The engine will go to idle speed and then stop from lack of fuel.

### **Module Control Circuit Breaker**

Electrical control circuits are assembled on plug-in circuit modules to facilitate maintenance. Local control power is supplied to many of the circuit boards. This circuit breaker protects the local control circuit to the boards.

### **Rev. Control Circuit Breakers**

This double pole circuit breaker is located in the feed to the operating motor of the multi-pole, motor operated, ganged switches that control the direction of current flow through the traction motor fields and thus control the direction of locomotive travel. Since control power is required to move the RV transfer switchgear from any position to any other position, the REV circuit breaker must be closed for power transfer to take place. An open REV circuit breaker does not prevent switchgear from already being in position to properly conduct traction motor current, but interlocking prevents an operating setup in conflict with transfer switch position.

### **AC Control Circuit Breaker**

The D14 alternator is the power supply for various excitation and wheel slip control devices. This circuit breaker is employed to protect the circuitry. The No AC Voltage relay NVR is also located in this circuit. If the circuit breaker trips during locomotive operation, a NO POWER alarm will be given.

### **Brake Trans. Control Circuit Breaker**

On units equipped with dynamic brakes, this double pole circuit breaker is located in the feed to the operating motor of the multi-pole, motor operated, ganged switches that control the motor field and armature connections for either dynamic braking or power operation. Since control power is required to move the MB transfer switchgear from any position to any other position, the brake transfer control circuit breaker must be closed for power transfer to take place. An open brake transfer control circuit breaker does not prevent switchgear from already being in position to properly conduct motor or braking current, but interlocking prevents an operating setup in conflict with transfer switch position.



## **Generator Field Circuit Breaker**

The AR10 generator receives its excitation through a pair of slip rings connected to the D14 alternator output through a controlled rectifier. The circuit breaker is provided to protect the controlled rectifier and the generator field windings.

## **Auxiliary Generator Circuit Breaker**

On special order this circuit breaker is applied in place of the auxiliary generator fuse.

## **Filter Blower Motor Circuit Breaker**

A blower is used to evacuate dirty air from the central air compartment inertial filters. This circuit breaker is provided to protect the blower motor circuit.

## **MISCELLANEOUS CIRCUIT BREAKERS**

### **Cab Heater Circuit Breaker**

Protects the circuit to the cab heater blower motors.

### **Lights Circuit Breaker**

This circuit breaker must be ON to supply power for the individual switches provided for number, class, platform, cabinet, hood, controller, and ground and gauge lights.

### **Headlights Circuit Breaker**

This circuit breaker protects the headlight circuits. It must be ON to provide current to the front headlight circuit and through the trainline to the light at the rear of a consist.

### **Water Cooler Circuit Breaker**

When an electric water cooler is provided, this circuit breaker protects the circuit.

### **Toilet Circuit Breaker**

When a flush type toilet is provided, an electric immersion heater prevents freezing of flush tank water. This circuit breaker protects the circuit.

### **Overspeed Circuit Breaker**

Train overspeed, sensed by the locomotive speed recording instrument, brings about a penalty application of the brakes and operation of a pneumatic control switch to drop locomotive power. When the overspeed circuit breaker is applied, it protects the overspeed magnet valve, circuit.

### **Radio Circuit Breaker**

Protects radio, circuits.

### **A.T.C. Circuit Breaker**

When automatic train control is applied, this circuit breaker protects the circuits.

## **Automatic Water Drain Circuit Breaker**

On units equipped for automatic draining of the engine cooling system, a temperature switch in cab heater piping under the cab energizes automatic drain valves when the temperature at the switch approaches freezing and the engine is shut down. This circuit breaker protects the circuit. The circuit breaker can also be used to nullify temperature switch response and allow filling a cold engine with cold water.

### **CAUTION:**

Make certain that the circuit breaker is closed after engine warmup following a newly filled system, and always make certain that cab heater supply and return valves, Fig. 3-6, are open during freezing weather.

## **Warning And Electronic Devices Circuit Breakers**

Provision is made for application of circuit breakers to protect special warning or electronic devices.

## **Ground Relay Lockout Reset Pushbutton**

On special order the locomotive may be equipped for lockout of the ground relay reset after a specific number of ground relay actions. This pushbutton releases the lockout.

## **Open Circuit Protection Reset Switch**

Units with extended range dynamic brakes are equipped with a latching relay that operates when an open exists in the dynamic braking resistor grid circuit. This switch resets the latching relay.

### **CAUTION:**

This circuit is to be reset only by qualified maintenance personnel after a thorough inspection of the dynamic braking grids, cables, blowers, and grid shorting contacts.

## ENGINE CONTROL PANEL, Fig. 2-4

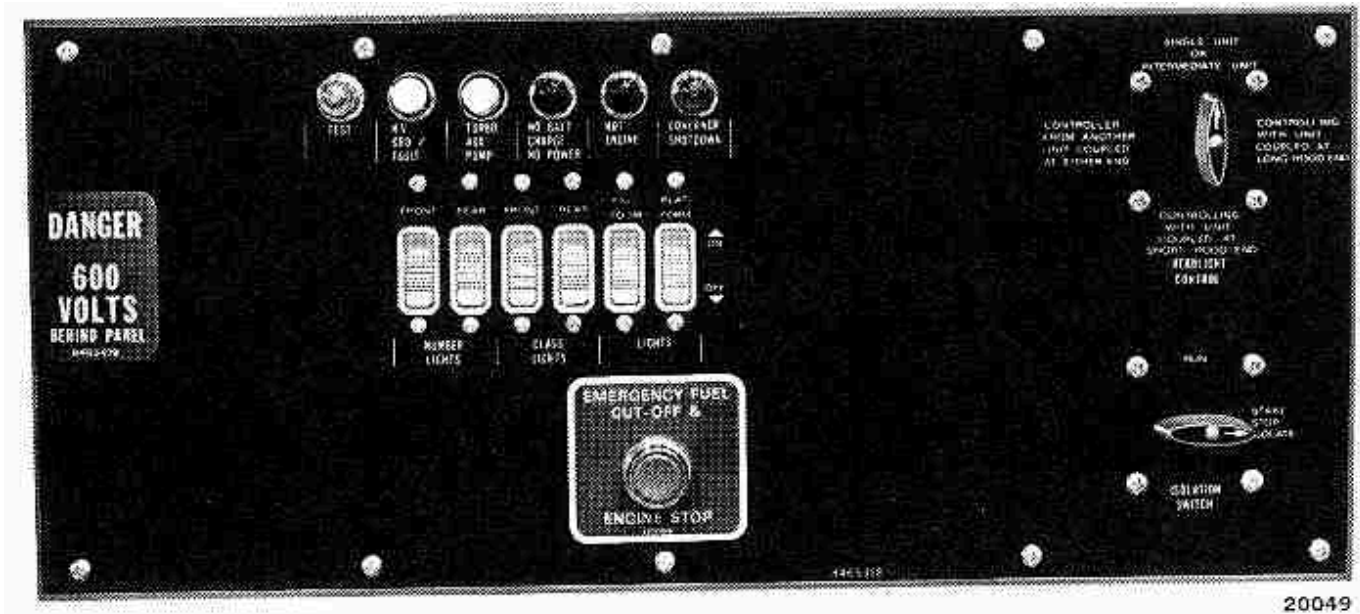

Fig. 2-4 - Typical Engine Control Panel

This engine control panel is located at the upper left hand corner of the electrical cabinet that forms the rear wall of the cab. This panel contains various switches and alarm lights. Since all of these items will be used at one time or another during operation, a brief description of their individual functions is provided.

By special order press-to-test indicating lights are used. A lamp test capability is provided with these lights. To test a particular lamp, merely apply finger pressure to that lens cap. A small time delay, possibly up to one second, will occur before the indicating light comes on.

Note that an alarm bell accompanies an alarm signal light indication. The bell will ring in all units of a locomotive consist, but the light will come on only in the affected unit.

### TEST Light

The test light comes on when the test panel rotary test switch is placed in the LOAD TEST or CIRCUIT CHECK position. The light indicates that the locomotive circuits are set up for either load testing when the reverser handle is centered or for circuit check with the generator field circuit breaker open. On special order the unit can be equipped to automatically load on its own dynamic braking resistor grids. On basic units the generator buses must be connected to an external loading resistor.

**CAUTION: On basic units the main generator will be open circuited if a load box is not connected during load test setup.**

## **H.V. GRD/FAULT Light**

This light indicates that an electrical path to ground has occurred, or that a group of five diodes in the main generator has failed. When the light comes on and the alarm sounds, the operator should wait 10 seconds, then press the ground reset button located on the control stand. Power will then reapply. It is not necessary to isolate the unit, nor is it necessary to have the throttle in idle while pressing the button.

If there is no ground reset button on the control stand, the locomotive will be equipped with special automatic ground relay reset, and the operator need take no action to reset the relay. Such automatic reset devices are equipped for lockout, and automatic reset will be nullified after either a specific number of trips or after a given number of trips with a time period. On the basic locomotive, when the high voltage ground/fault alarm occurs for the third time after using the ground reset button twice, the affected unit should be isolated.

### **CAUTION:**

Always report ground fault light indications to proper maintenance personnel.

## **TURBO AUX. PUMP Light**

This light will come on as soon as the main battery switch and turbo lube pump circuit breaker are closed. It indicates that the turbocharger auxiliary lube oil pump is supplying lube oil to the turbocharger. It will remain on for approximately 35 minutes after the main battery switch is closed. When the fuel prime engine start switch is operated after the 35 minute period, the time cycle is again re-established and the light remains on for another 35 minutes.

The light will also come on and remain on for approximately 35 minutes after the engine is stopped. It provides an indication that the auxiliary lube oil pump is supplying oil to cool the turbocharger bearings.

If the power supply to the turbo lube pump motor is open, the engine will not start and the light will fail to come on when a starting attempt is made.

## **NO BATT. CHARGE/NO POWER Light**

This light will come on and the alarm bell will sound whenever D14 alternator output stops - normally at engine shutdown. The indication can also be caused by true D14 failure or failure of the DC auxiliary generator. A tripped AC Control circuit breaker will also bring about the indication. In each case the locomotive will fail to deliver power.

## **HOT ENGINE Light**

This light operates in conjunction with the alarm bell to warn the operator that engine cooling water has reached an excessive temperature. When the light is on, engine speed and power are automatically reduced until the hot engine condition is corrected. If the cooling system has failed, a hot lubricating oil detector will shut the engine down before serious engine damage occurs. If hot engine shutdown occurs do not attempt to restart the engine. Report shutdown circumstances to authorized maintenance personnel.

## **GOVERNOR SHUTDOWN Light**

This light comes on when the engine governor has shut the engine down for one of the following reasons.

1. True low oil pressure.
2. Hot engine oil.
3. Low cooling water pressure, or any condition which causes the differential pressure across the water pump to drop below airbox pressure.
4. Crankcase (oil pan) overpressure.

A mechanism to detect low engine lubricating oil pressure is built into the engine governor. This mechanism is actuated by true oil pressure failure or by dumping oil from the engine oil line leading to the governor. In either event a small button will pop out of the governor body, indicating that the mechanism has tripped the low oil alarm switch. The light on the engine control panel will come on to indicate that the low oil mechanism has tripped.

When a governor shutdown indication occurs, it is necessary to determine whether the crankcase pressure-low water detector has tripped to dump engine oil from the line leading to the governor, or whether a true oil failure has occurred. This can be determined by checking the differential low water-crankcase pressure detector, Fig. 3-2, for protruding reset buttons. A protruding lower button indicates excessive oil pan pressure; a protruding upper button indicates low water.

### **WARNING:**

When it is determined that the crankcase pressure detector has tripped, make no further engineroom inspections. Do not attempt to restart the engine. Isolate the unit. Drain the cooling system in accordance with railroad regulations. If neither the crankcase pressure nor the low water pressure detector has tripped, and engine oil level is satisfactory with a hot engine condition apparent, do not attempt to restart the engine. Report engine shutdown circumstances to authorized maintenance personnel.

## **FILT. MOTOR TRIP Light (If Provided)**

This light indicates that the carbody inertial filter exhaust blower motor is not receiving power. Check for a tripped filter blower motor circuit breaker on the circuit breaker panel. If the breaker will not reset, operation may continue to the nearest maintenance point where the condition should be reported and corrected.

## **LOCK WHEEL Light (If Provided)**

This light indicates a locked wheel condition and- will be accompanied by a continuous wheel slip light, alarm bell, and buzzer. Observe the following:

# LOCKED WHEEL CONTINUOUS WHEEL SLIP LIGHT AND ALARM BELL

## PROCEDURE

- 1. STOP TRAIN**
- 2. LOOK FOR UNIT WITH LOCKED WHEEL INDICATION**
- 3. ROLL TRAIN SLOWLY AND OBSERVE WHEELS**

### **A. IF WHEEL SLIDES, CUT UNIT OUT OF TRAIN**

### **B. IF ALL WHEELS ROLL AND L.W. RESETS AUTOMATICALLY, PROCEED NORMALLY**

#### **WARNING:**

The operator must not operate any reset or cutout switches on the locked wheel circuit module. If automatic reset follows a locked wheel indication, report the condition at the nearest maintenance point, where an inspection can be made for flat spots on the wheels.

#### **Remote Traction Motor Cutout Switch (If Provided)**

The traction motor cutout switch operates to electrically isolate a defective traction motor along with an electrically related motor. This permits operation with the remaining good motors. The power control system automatically limits power to prevent overloading the operative motors. The isolated motors will continue to rotate as the train moves, therefore the locked wheel detection system remains fully effective.

To operate the motor cutout switch it is first necessary to place the isolation switch on the engine control panel in ISOLATE position. The switch is then pressed in and turned to cut out the desired pair of motors. Make certain that all wheels rotate freely before operating with a motor or motors cut out.

#### **Miscellaneous Switches**

Switches are included in circuits for various lights and devices on the locomotive. The switches are closed as desired to operate the class lights, the number lights, the engine room lights, and the platform lights.

#### **Dynamic Brake Cutout Switch (if Provided)**

On units so equipped, when this switch is placed in the CUTOUT position, the individual unit will not operate in dynamic braking. It will however, continue to operate normally under power. The switch can be used to limit the number of units in a consist that will operate in dynamic braking, or it may be used to cut out a unit that is defective in dynamic braking, yet allow it to operate under power.

#### **Locked Wheel Cutout And Reset Switch (If Provided)**

For the locked wheel detection system to be operational, this switch must be in the LOCKED WHEEL (up) position. The locked wheel detection system is then effective whether the unit is under power, is shut down, is isolated, or has motors cut out. When the switch is in CUTOUT & RESET position, locked wheel detection is nullified; however, the wheel slip control system will provide protection against a locked wheel on any units under power without motors cut out.

Should a temporary operating condition such as unequal release of air brakes bring about a locked wheel indication, automatic reset will occur when the wheel again turns freely. When a locked wheel indication is received, follow the procedure outlined under the LOCK WHEEL light paragraph in this manual.

## **Emergency Fuel Cutoff And Engine Stop Pushbutton**

The diesel engine will stop whenever the engine stop pushbutton is pressed. The reaction to the pushbutton is immediate and it need not be held in until the engine stops.

## **Headlight Control Switch**

The twin sealed-beam front and rear headlights are controlled by the front and rear headlight switches on the locomotive control stand. Before these switches will function, the headlight circuit breaker must be placed ON.

On locomotives equipped for multiple unit operation, a remote headlight control switch is mounted on the engine control panel. This remote headlight control switch provides for operation of the rear unit headlight from the lead unit. The switch positions are set on each unit as follows:

### **1. On Lead Unit**

If only a single locomotive unit is being used, place the switch in SINGLE UNIT position.

In multiple unit service, if trailing units are coupled to the No. 2 or long hood end of the lead unit, place the switch in the CONTROLLING - COUPLED AT LONG HOOD END position.

In multiple unit service, if trailing units are coupled to the No. 1 or short hood end of the lead unit, place switch in CONTROLLING - COUPLED AT SHORT HOOD END position.

### **2. On Intermediate Units**

On units operating in between other units in a multiple unit consist, place the switch in the INTERMEDIATE UNIT position.

### **3. On Trailing Units**

The last unit in a multiple unit consist should have the headlight control switch placed in the CONTROLLED -- COUPLED AT EITHER END position.

## **Isolation Switch**

The isolation switch has two positions, one labeled START/ STOP/ ISOLATE, the other labeled RUN. The functions of these two positions are as follows:

### **1. START/STOP/ISOLATE Position**

The isolation switch is placed in this position whenever the diesel engine is to be started. The start switch is effective only when the isolation switch is in this position.

This position is also used to isolate the unit, and when isolated the unit will not develop power or respond to the controls. In this event the engine will run at idle speed regardless of throttle position. This position will also silence the alarm bell in the event of a no power or low lube oil alarm. It will not, however, stop the alarm in the event of a hot engine.

If the locomotive is equipped with the remote traction motor cutout switch feature, the isolation switch must be placed in the ISOLATE position before the cutout switch can be operated.

### **2. RUN Position**

After the engine has been started, the unit can be placed "on the line" by moving the isolation switch to the RUN position. The unit will then respond to control and will develop power in normal operation.

## Battery Charging Indicator (if Provided)

This indicator may be applied on special order. It indicates current flowing to or from the storage battery. It does not indicate output of the auxiliary generator. Since the storage battery is usually well charged, the indicator in normal operation should read zero or slightly in the green area. The pointer should never be in the red area with the diesel engine running, even at idle speed. Such a reading indicates that the battery is discharging, which if allowed to continue could lead to failure of the locomotive unit.

## LOCOMOTIVE CONTROL STAND, Fig. 2-5

The locomotive control stand contains the switches, gauges, and operating handles used by the operator during operation of the locomotive. The individual controller components are described, together with their functions, in the following paragraphs.

### Controller, Fig. 2-6

The following operating handles are located on the controller panel.

### Dynamic Brake Handle, Fig. 2-7

A separate handle is provided for control of dynamic brakes. It is uppermost on the controller panel and is moved from left to right to increase braking effort. The handle grip is somewhat out-of-round with the flattened surfaces vertical to distinguish it from the throttle handle, which has its flattened surfaces horizontal. The brake handle has two detent positions; OFF and SETUP, and an operating range I through FULL 8, through which the handle moves freely without notching. Mechanical interlocking prevents the dynamic brake handle from being moved out of the OFF position unless the throttle is in IDLE and the reverser is positioned for either forward or reverse operation.

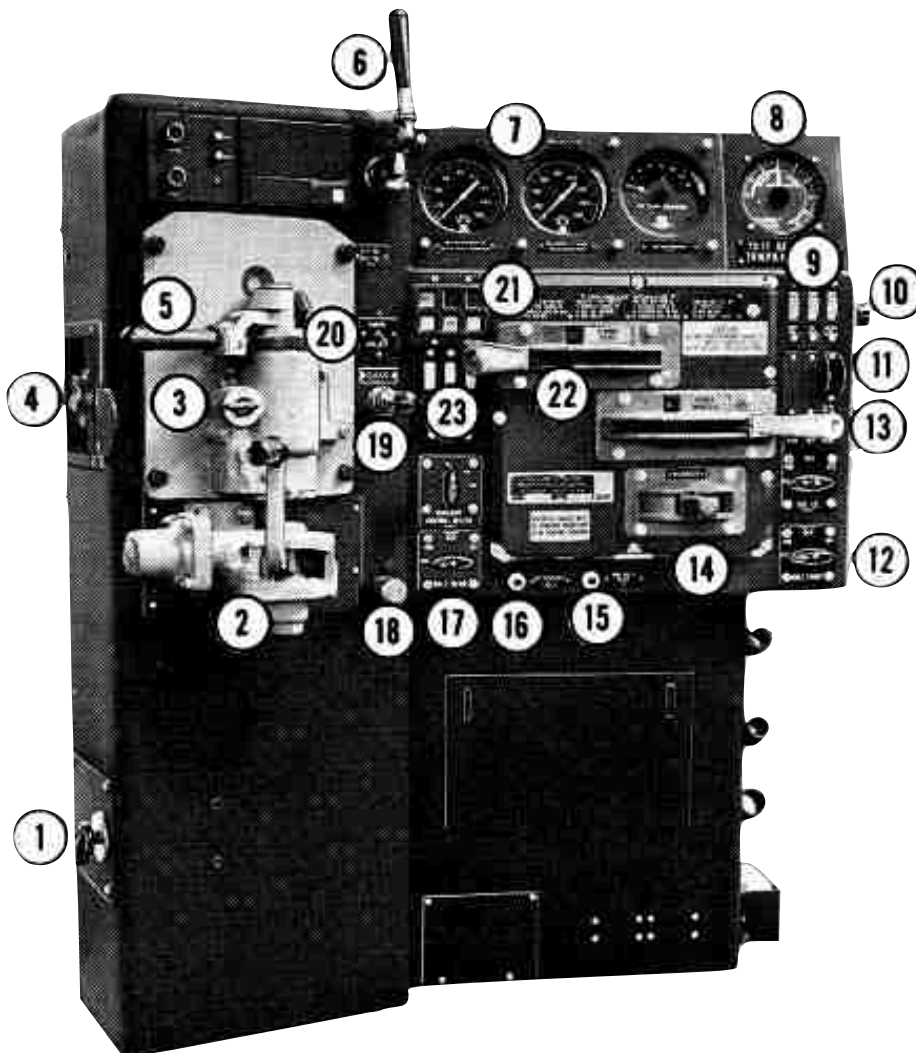



1.	Multiple Unit Valve	12.	Headlight Switch-Front
2.	Independent Brake Valve	13.	Throttle Handle
3.	Cut-Off Valve	14.	Reverser Handle
4.	Trainline Air Pressure Adjustment Valve	15.	Ground Reset Button
		16.	Attendant Call Button
5.	Automatic Brake Valve	17.	Headlight Switch-Rear
6.	Air Horn Valve	18.	Bell Ringer Valve
7.	Air Gauges	19.	Manual Sand Lever Switch
8.	Load Current Indicating Meter	20.	Lead Truck Sand Switch
9.	Control And Operating Switches	21.	Indicator Light Panel
10.	Light Dimmer	22.	Dynamic Brake Handle
11.	Dynamic Brake Circuit Breaker	23.	Ground And Gauge Light Switches

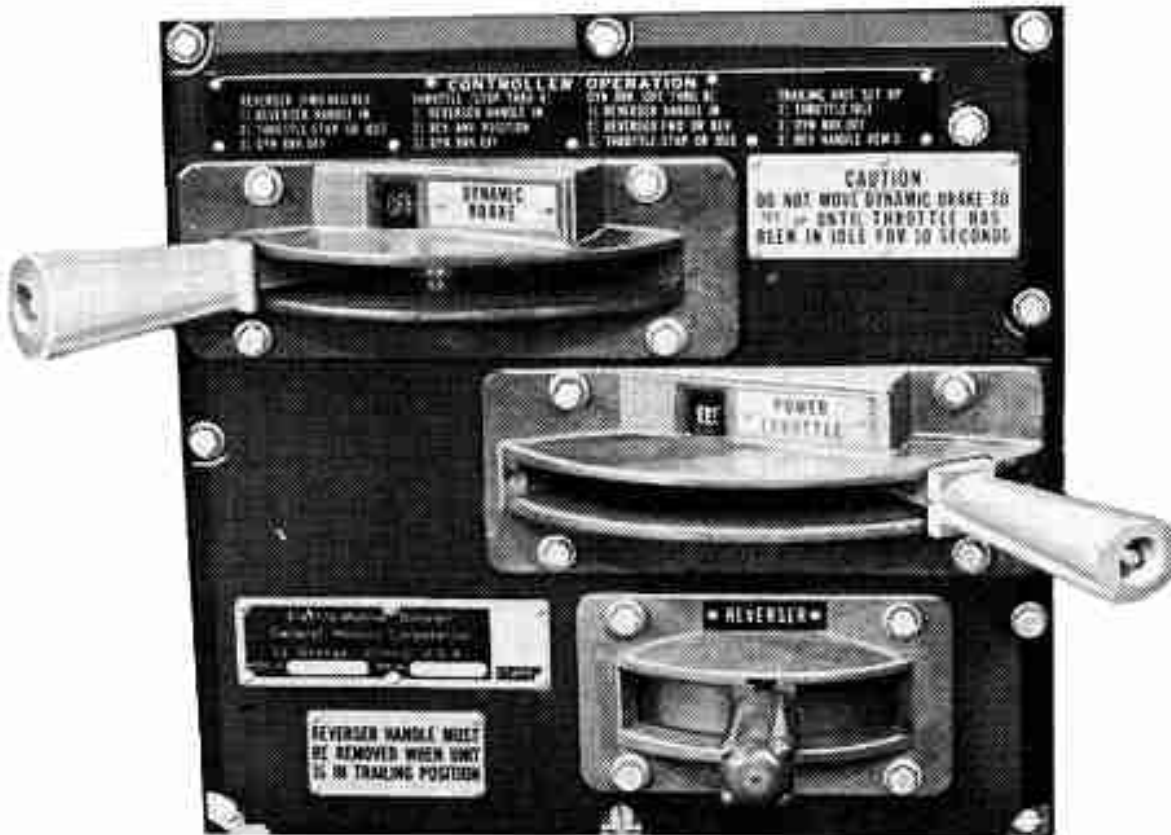

22715

Fig. 2-6 - Locomotive Controller

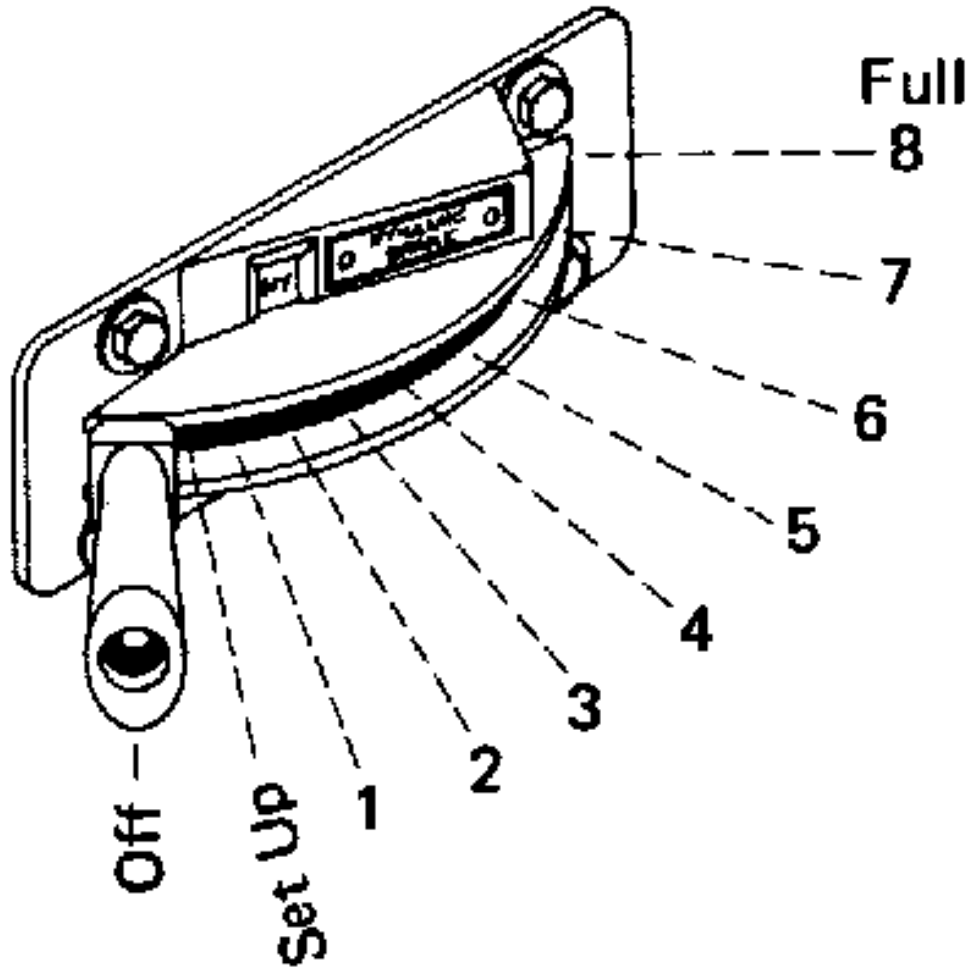

Fig. 2-7 - Dynamic Brake Handle

**CAUTION:**

During transfer from power operation to dynamic braking, the throttle must be held in IDLE for 10 seconds before moving the dynamic brake handle to the SET UP position. This is to eliminate the possibility of a sudden surge of braking effort with possible train run-in or motor flashover.

### Throttle Handle, Fig. 2-8

The throttle handle is located just below the dynamic brake handle. It is moved from right to left to increase engine speed and power. The handle grip is somewhat out-of-round, with the flattened surface horizontal to distinguish it from the dynamic brake handle. The throttle has nine detent positions; IDLE, and I through 8 plus a STOP position, which is obtained by pulling the handle outward and moving it to the right beyond IDLE to stop all engines in a locomotive consist. Mechanical interlocking prevents the throttle handle from being moved out of IDLE into power positions when the dynamic brake handle is advanced to SET UP or beyond, but it can be moved into STOP position to stop all engines in the consist. The throttle can not be moved when the reverser handle is centered and removed from the controller.

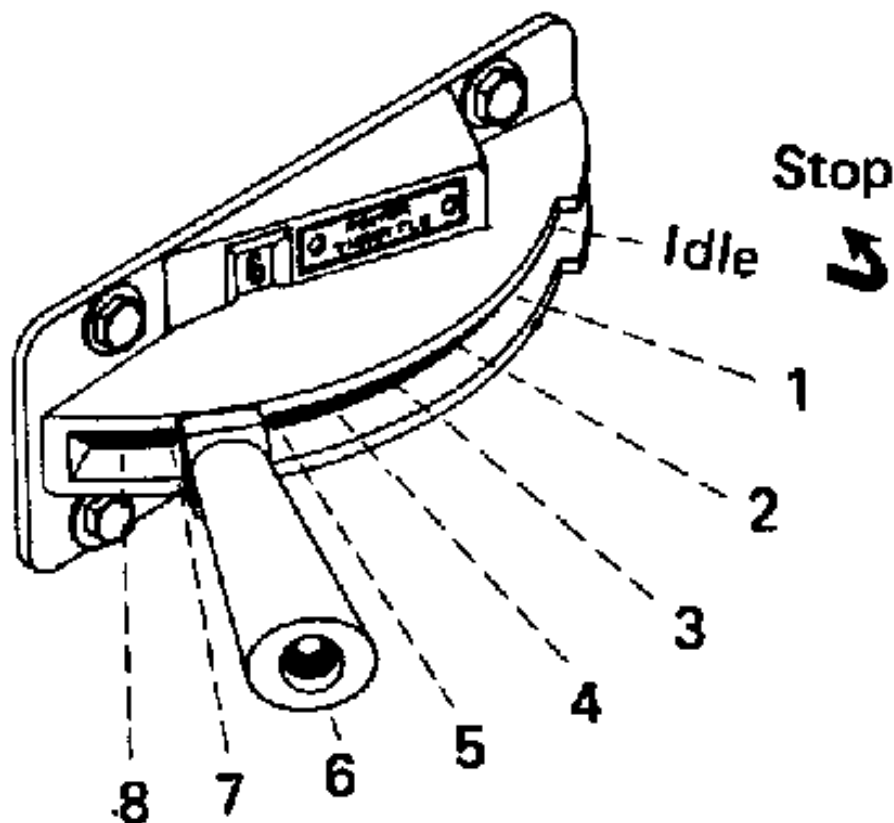

### Reverser Handle, Fig. 2-9

The reverser handle is the lowest handle on the controller panel. It has three detent positions; left, centered, and right. When the handle is moved to the right toward the short hood end of the unit, circuits are set up for the locomotive to move in that direction. When the handle is moved to the left toward the long hood end, the locomotive will move in that direction when power is applied. With the reverser handle centered, mechanical interlocking prevents movement of the dynamic brake handle, but the throttle handle can be moved to increase engine speed. In such case, power will not be applied to the traction motors. The reverser handle is centered and removed from the panel to lock the throttle in IDLE position and the dynamic brake handle in OFF position.

## MECHANICAL INTERLOCKS ON THE CONTROLLER

The handles on the controller are interlocked so that:

- 1. With reverser handle in neutral (centered) -
  - a. Dynamic brake handle can not be moved out of OFF position.
  - b. Throttle can be moved to any position.
  - c. Reverser handle can be removed from controller if throttle is in IDLE position.
  
- 2. Reverser handle in forward or reverse -
  - a. Throttle can be moved to any position if dynamic brake handle is in OFF position.
  - b. Dynamic brake handle can be moved to any position if throttle is in IDLE position.
  
- 3. Reverser handle removed from controller -
  - a. Throttle locked in IDLE position.
  - b. Dynamic brake handle locked in OFF position.
  
- 4. Throttle in IDLE position -
  - a. Dynamic brake handle can be moved to any position if reverser is in forward or reverse position.
  - b. Reverser handle can be placed in neutral, forward, or reverse position if dynamic brake handle is in OFF position.
  -
  
- 5. Throttle above IDLE position -
  - a. Dynamic brake handle can not be moved.
  - b. Reverser handle can not be moved.
  
- 6. Dynamic brake handle in OFF position
  - a. Throttle can be moved to any position.
  - b. Reverser handle can be moved to any position if throttle is in IDLE position.
  
- 7. Dynamic brake handle moved out of OFF position -
  - a. Throttle can not be moved out of IDLE position into power positions, but can be moved into STOP position.
  - b. Reverser handle can not be moved out of forward or reverse into OFF position.

## AIR BRAKE EQUIPMENT, Fig. 2-10

Basic locomotives are equipped with the type 26L air brakes. Since type 26L is standard equipment, only that type of air brake will be discussed in this manual.

The 26L air brake control equipment is located to the left of the controller. This equipment consists of an automatic brake, independent brake, multiple unit valve (when MU control is installed), cutoff valve, and a trainline air pressure adjustment device.

**Fig. 2-10 - Air Brake Equipment**

The dead engine feature (not shown in Fig. 2-10) is also part of the 26L equipment. The dead engine cutout cock and pressure regulator, Fig. 2-11, are accessible from outside the locomotive through side doors provided. The pressure regulator is set at the maintenance point and is not to be set by the operator.

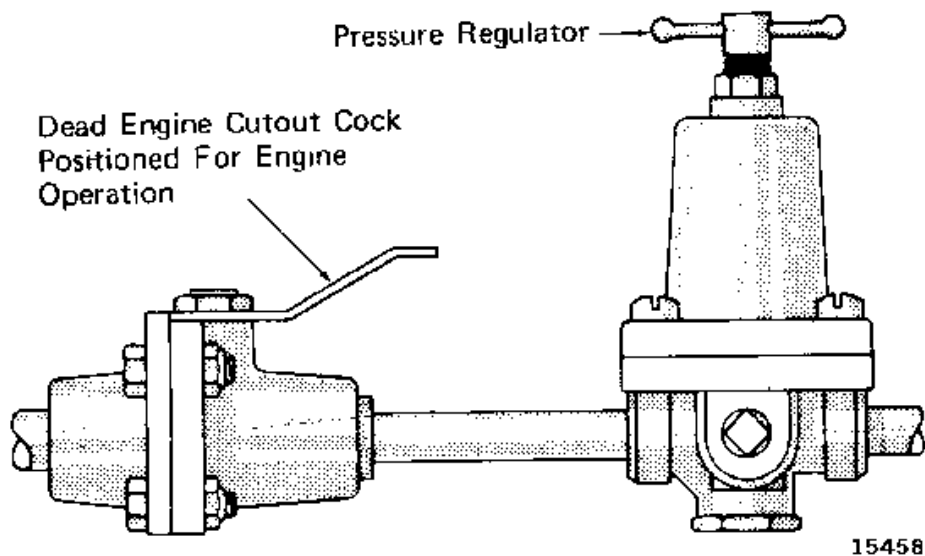

**Fig. 2-11 - Dead Engine Cutout Cock  
And Pressure Regulator**

### Automatic Brake Valve, Fig. 2-12

The automatic brake valve handle may be placed in any of six operating positions.

### Independent Air Brake, Fig. 2-13

The independent air brake handle is located directly below the automatic brake handle. It has two positions; namely, release and full application. Between these two positions is the application zone. Since this is a self-lapping brake, it automatically laps off the flow of air and maintains brake cylinder pressure corresponding to the position of the handle in the application zone.

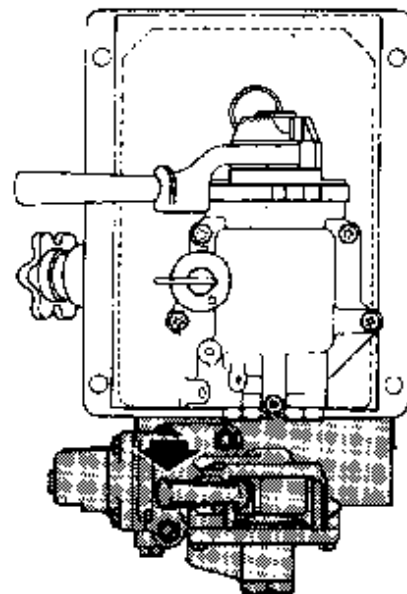
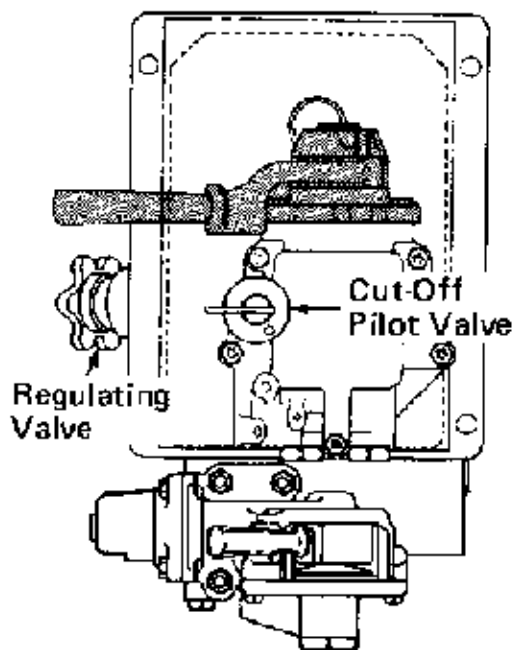
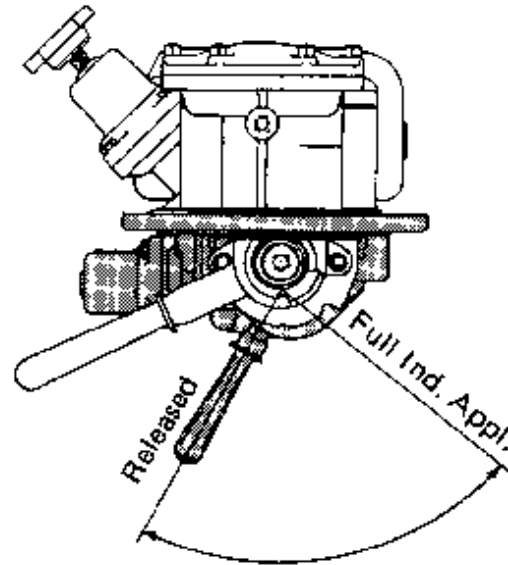
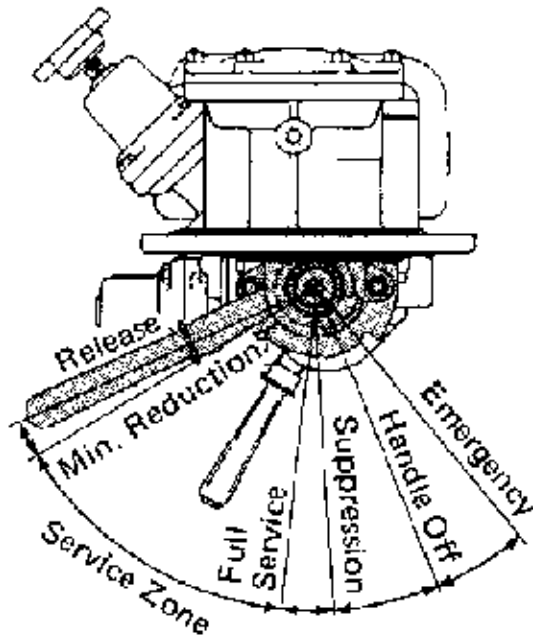

## **Multiple Unit Valve**

The multiple unit (MU-2) valve is located on the left hand side of the air brake stand. Its purpose is to pilot the FI selector valve which is a device that enables the air brake equipment of one locomotive unit to be controlled by that of another unit.

The basic MU-2 valve has three positions which are:

1. LEAD or DEAD
2. TRAIL 6 or 26\*
3. TRAIL 24

The valve is positioned by pushing in and turning to the desired setting.

\*Whenever the MU-2 valve is in the TRAIL 6 or 26 position, and if actuating trainline is not used, then the actuating end connection cutout cock must be opened to atmosphere. This is necessary to prevent the inadvertent loss of air brakes due to possible pressure build-up in the actuating line..

## **Cut-Off Valve**

The cut-off valve is located on the automatic brake valve housing directly beneath the automatic brake valve handle. This valve has the following three positions:

1. OUT
2. FRT (Freight)
3. PASS (Passenger)

## **Trainline Pressure Adjustment**

The trainline air pressure adjusting knob is located behind the automatic brake valve at the upper portion of the brake stand. With the automatic brake valve handle in release position, it is used to obtain the brake pipe pressure desired. The automatic brake valve will maintain the selected pressure against overcharge or leakage.

## **BRAKE EQUIPMENT POSITIONS, Fig. 2-14**

When operating locomotives equipped with 26L air brakes, the brake equipment should be positioned according to the information given in the equipment position chart.

## **SWITCHES AND LIGHTS ON THE CONTROL STAND**

### **Bell Ringer**

When the bell ringer is operated, compressed air is directed to the locomotive warning bell operator.

### **Sanding Switches**

#### **1. SANDING NO. 1 TRUCK Toggle Switch**

The signal from this switch is not trainlined. The switch provides sand to only the number I axle of the lead unit of a consist. This method of sanding dresses the rail and is adequate for most conditions. The SAND light will be on when this switch is in the on (up) position.

#### **2. Sanding Wobble Stick**

Movement of this device closes a switch that initiates directional sanding on all units of a locomotive consist.

\*Whenever the MU-2 valve is in "Trail 6 or 26" Position and if the actuating train line is not used, then the actuating end connection cutout cock must be open to atmosphere; so as to prevent the inadvertent loss of air brakes due to possible pressure buildup in the actuating line

NOTE: By AAR standard all cocks in the brake system except brake pipe end cocks have handles perpendicular to pipe when open.

### **Fig. 2-14 - Brake Equipment Positions**

Electrically controlled sanding is the basic system used but since the locomotive may be operated in multiple with older units that are equipped only for pneumatic control of sanding, trainlined pneumatic control of sanding may be provided as an optional extra in addition to electrical control. In such cases, trainlined actuating pipes must be connected between units.



## Indicating Lights Panel, Fig. 2-15

This assembly is located adjacent to the upper left corner of the controller. The purpose of the assembly is to provide a visual warning of operating difficulties. The unit has provisions for six press-to-test lights covered by either white or colored lens caps identified by black block letters.

**NOTE: A delay of about one second occurs between pressing the indicating lens cap and illumination of the indicator.**

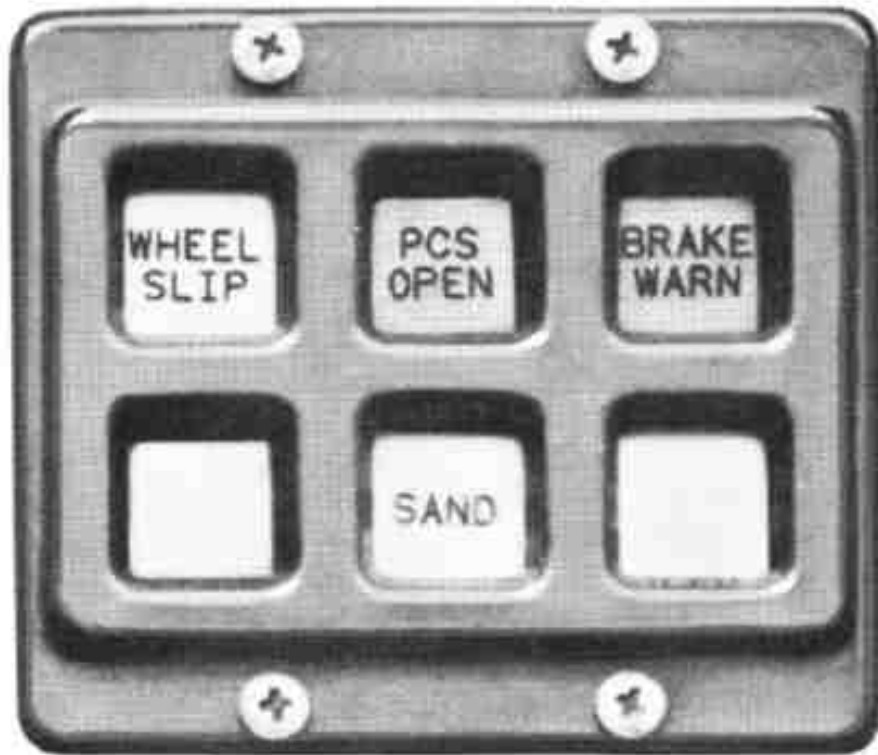

19271

**Fig. 2-15 -- Indicating Lights Panel**

The four basic lights installed are wheel slip, PCS open, brake warning, and sand. The functions of these lights are as follows:

### 1. Wheel Slip light

Intermittent flashing of the wheel slip light indicates that the wheel slip control system is doing its job and is correcting the slips. The throttle and locomotive power should not be reduced unless severe lurching threatens to break the train.

Note that minor slips or wheel creep will not activate the wheel slip light, but automatic sanding may take place along with regulation of power to the wheels. Do not misinterpret this power control as loss of power due to a fault.

### **WARNING:**

A wheel slip light flashing persistently or burning continuously may indicate a pair of sliding wheels or circuit difficulty. Stop the locomotive and make a careful inspection to ascertain that there are no locked sliding wheels.

On locomotives equipped with the locked wheel detection system, a continuous wheel slip light accompanied by the alarm indicates a locked wheel. The LOCK WHEEL light on the engine control panel will also be on. Observe the locked wheel indication instruction plate.

### 2. PCS OPEN Light

The PCS or pneumatic control switch functions to automatically reduce locomotive power in the event that an emergency or safety control air brake application occurs. It does so by reducing the speed of ALL engines to idle.

### **CAUTION:**

The engine run switch should be in the off (down) position in all trailing units, or (depending on the type and position of locomotives in the consist) it is possible that the PCS switch of the lead will not act to reduce engine speeds to idle.

When the switch is tripped, the PCS OPEN light will come on. This light is extinguished and locomotive power restored by resetting the PCS switch. This occurs automatically, provided that:

- a. Control of the air brake is recovered.
- b. The throttle is returned to IDLE position.

### 3. Brake Warning

A brake warning light is installed on units equipped with dynamic brakes and functions in conjunction with a brake warning relay. The purpose of the relay and light is to indicate excessive braking current.

In the event that the brake warning light comes on and does not go out quickly, reduce braking handle position immediately to decrease braking strength and prevent possible equipment damage. If the brake warning indication repeats, place the dynamic brake cutout switch on the engine control panel of the affected unit in the CUTOUT position. The unit will then operate normally under power, but not in dynamic braking. Total braking effort of the consist will be reduced.

### 4. Sand

This light comes on to indicate that the SANDING No.1 TRUCK switch is closed and that sand is being applied to the No. 1 axle. The light is not affected by the manual, emergency, or wheel slip sanding circuits.

### **Air Gauges**

Air gauges to indicate main reservoir air pressure as well as various pressures concerned with the air brakes are prominently located along the top of the controller.

## Load Current Indicating Meter

Locomotive pulling force is indicated by the load current indicating meter at the upper right portion of the control stand. The meter is graduated to read amperes of electrical current, with 1500 being the maximum reading on the scale. A red area on the meter face indicates when current levels are too high for continuous operation. A short time rating plate near the meter gives the time limitations at various current levels. The times are non-accumulative; that is, considering the conditions under which a locomotive operates it is not necessary to add intermittent periods requiring high current operation. The meter is connected so as to indicate the current flowing through the No. 2 traction motor. Since the amperage is the same in all motors, each motor will carry the amount shown on the meter.

On special order the meter may be color coded to indicate operating time limits at various meter pointer positions.

On locomotives equipped for dynamic braking, a zero-center type meter is applied, Fig. 2-16. The meter needle swings to the right of zero to indicate load current during power operation, and it swings to the left of zero to indicate dynamic braking current, with 800 amperes being the maximum reading on the braking portion of the meter.

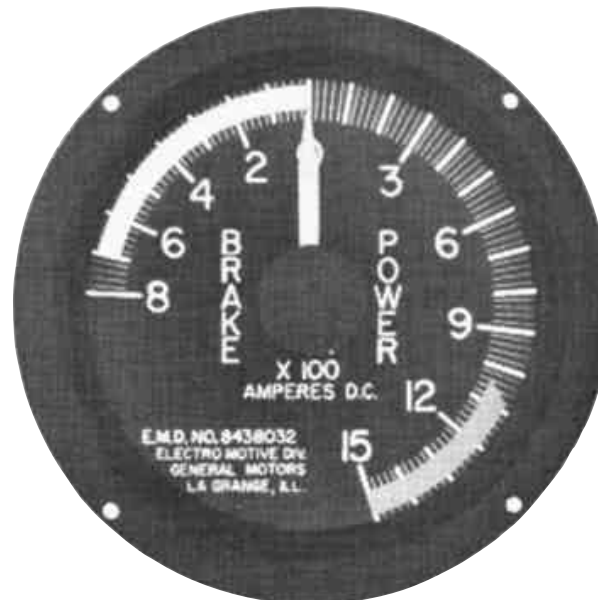

17515

**Fig. 2-16 -- Load/Brake Current Indicating Meter**

Since the dynamic brake regulator controls maximum braking current, the meter should seldom if ever indicate more than 700 amperes, which is the rating of the dynamic braking resistor grids.

### **NOTE:**

The wheel slip control system functions to correct slips by instantaneous reduction of power in small increments and by application of sand. The cumulative effect of a large number of power reductions in rapid succession is to cause the locomotive to maintain power at a level where adhesion can be maintained. Do not misinterpret this loss of power as a defect in the control system.

## Control And Operating Switches, Fig. 2-17

A group of three operating switches is located at the upper right corner of the control stand. They snap into the on position when moved upward. The switches must be on in the lead unit of a locomotive consist, and must be off in trailing units.

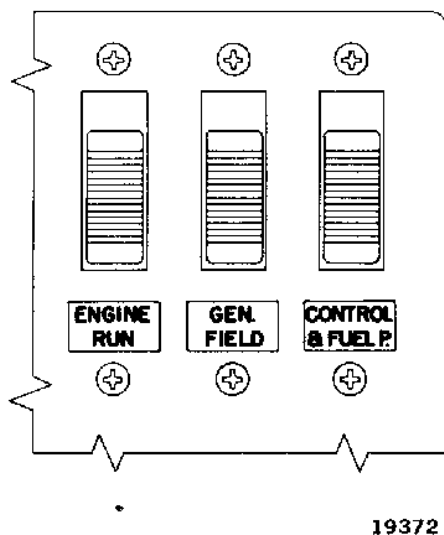

Fig- 2-17 - Control And Operating Switches

### 1. Control And Fuel Pump Switch

Provides power to various low voltage control circuits. The switch must be on to start the engine and operate the fuel pump.

### 2. Engine Run Switch

Must be on to obtain control of engine speed.

### 3. Generator Field Switch

Must be on to obtain power from the locomotive.

## Headlight Switches

Two four-position rotary snap switches are provided for independent control of the front and rear headlights. Each switch has OFF, DIM, MED, and BRT positions. All positions of each switch are operative, but in a multiple unit consist, the headlight control switches on the engine control panels of each unit in a consist must be properly positioned, and only the lead unit controls the headlights.

For these switches to function, the headlight circuit breaker must be on.

## Miscellaneous Switches

Switches for the ground lights, step lights, and gauge lights are provided at the left side of the controller. The lights are on when the switches are in the UP position.

## **Dynamic Brake Control Circuit Breaker**

On locomotives equipped for dynamic braking, this circuit breaker is provided to protect against a faulty operating or test setup. The circuit breaker should be in the on (up) position for normal operation. A tripped circuit breaker generally indicates that at some time during makeup of a locomotive consist more than one dynamic brake handle was out of OFF position at one time.

## **Attendant Call Pushbutton**

When this button is pressed in any unit of a locomotive consist, the alarm bells ring in all units of the consist.

## **High Voltage Ground/Fault Reset Pushbutton**

The ground relay detects high voltage grounds during operation under power. When it trips, the alarm bells ring in all units of a consist. On the unit affected, generator excitation is lost, the diesel engine goes to idle speed, and the high voltage ground/fault light on the engine control panel comes on.

Available on special order, the ground relay can also be used to detect braking grid grounds that occur during dynamic braking.

To reset the ground relay and restore locomotive power, wait 10 seconds and press the high voltage ground reset pushbutton on the locomotive control stand. It is not necessary to isolate the unit nor is it necessary to place the throttle in idle position before pressing the reset button unless the locomotive is at a standstill.

Repeated resetting of the ground relay is permissible, but instructions as issued by the railroad regarding repeated resetting must be followed. However, in the absence of definite instructions to the contrary, isolate a unit when the ground/fault light comes on for the third time after resetting.

### **CAUTION:**

Always report high voltage ground/fault light indications to proper maintenance personnel.

# SECTION 3

## OPERATION

### INTRODUCTION

This section of the manual covers recommended procedures for operation of the locomotive. The procedures are briefly outlined and do not contain detailed explanations of equipment location or function.

The information in this section is arranged in sequence, commencing with inspections in preparation for service, and with instructions for starting the engine, handling a light locomotive, coupling to train, and routine operating phases. The various operating situations and special features such as dynamic braking are also covered.

### PREPARATION FOR SERVICE

#### GROUND INSPECTION

Check locomotive exterior and running gear for:

1. Leakage of fuel oil, lube oil, water or air.
2. Loose or dragging parts.
3. Proper hose connections between units in multiple.
4. Proper positioning of all angle cocks and shut-off valves.
5. Air cut-in to truck brake cylinders.
6. Satisfactory condition of brake shoes.
7. Adequate supply of fuel.

## **LEAD UNIT CAB INSPECTION**

On the lead or control unit, the control locations described in Section 2 should be checked and the equipment positioned for operation as follows:

### **Fuse And Switch Panel**

1. Main battery switch closed.
2. Ground relay switch closed.
3. All fuses installed and in good condition.

### **Circuit Breaker Panel**

1. All breakers in black area of panel in ON position.
2. Other circuit breakers ON as required.

### **Engine Control Panel**

1. Isolation switch in START position.
2. Headlight control switch in proper position for lead unit operation.
3. Dynamic brake cutout switch in DYN. BRAKE (up) position (if provided).
4. Locked wheel cutout and reset switch in LOCKED WHEEL (up) position (if provided).
5. Miscellaneous switches positioned as required.

#### **CAUTION:**

The electrical cabinet is pressurized with filtered air. Cabinet doors must be securely closed during locomotive operation.

### **Remote Traction Motor Cutout Switch**

On locomotives equipped with remote panel mounted traction motor cutout switch, the panel instructions adjacent to the switch must be followed exactly when a traction motor is to be cut out. The cutout switch can not be turned unless the unit is isolated and the local control circuit breaker is closed. Make certain that all wheels rotate freely before operating with a motor or motors cut out.

### **Locomotive Controller**

The controller switches and operating levers should be positioned as follows:

1. Place control and fuel pump switch in on (up) position.
2. Place engine run switch and the generator field switch in the off (down) position.
3. Position heater, lights, and miscellaneous switches as desired.
4. Make certain that the throttle remains in idle position and that the reverser handle is removed from the controller.

## **Air Brakes - Type 26L**

1. Insert automatic brake valve handle (if removed) and place in SUPPRESSION position. This will nullify the application of any safety control equipment used.
2. Insert independent brake valve handle (if removed) and move to FULL APPLICATION position.
3. Position cut-off valve to either FRT or PASS depending on make-up of train.
4. Place MU valve in LEAD position.

## **ENGINE ROOM INSPECTION**

The engine can be readily inspected by opening the access doors along the sides of the long hood end of the locomotive.

1. Check air compressor for proper lubricating oil supply.
2. Observe for proper water level on tank sight glass.
3. Check all valves for proper positioning.
4. Observe for leakage of fuel oil, lubricating oil, water or air.

## **ENGINE INSPECTION**

The engine should be inspected before as well as after starting. After inspection and engine start, all engine room doors should be closed and latched securely, as engine room is pressurized during operation.

1. Check to see that engine overspeed lever is set, Fig. 3-1.
2. Observe that governor low oil pressure trip plunger, Fig. 3-1, is set and that there is oil visible in the governor sight glass.
3. Observe that the differential low water and crankcase (oil pan) pressure detector reset buttons are set (pressed in). If the buttons protrude, press and hold for 5 seconds immediately after engine starts, Fig. 3-2.
4. Observe that engine top deck, air box, and oil pan inspection covers are in place and are securely closed.



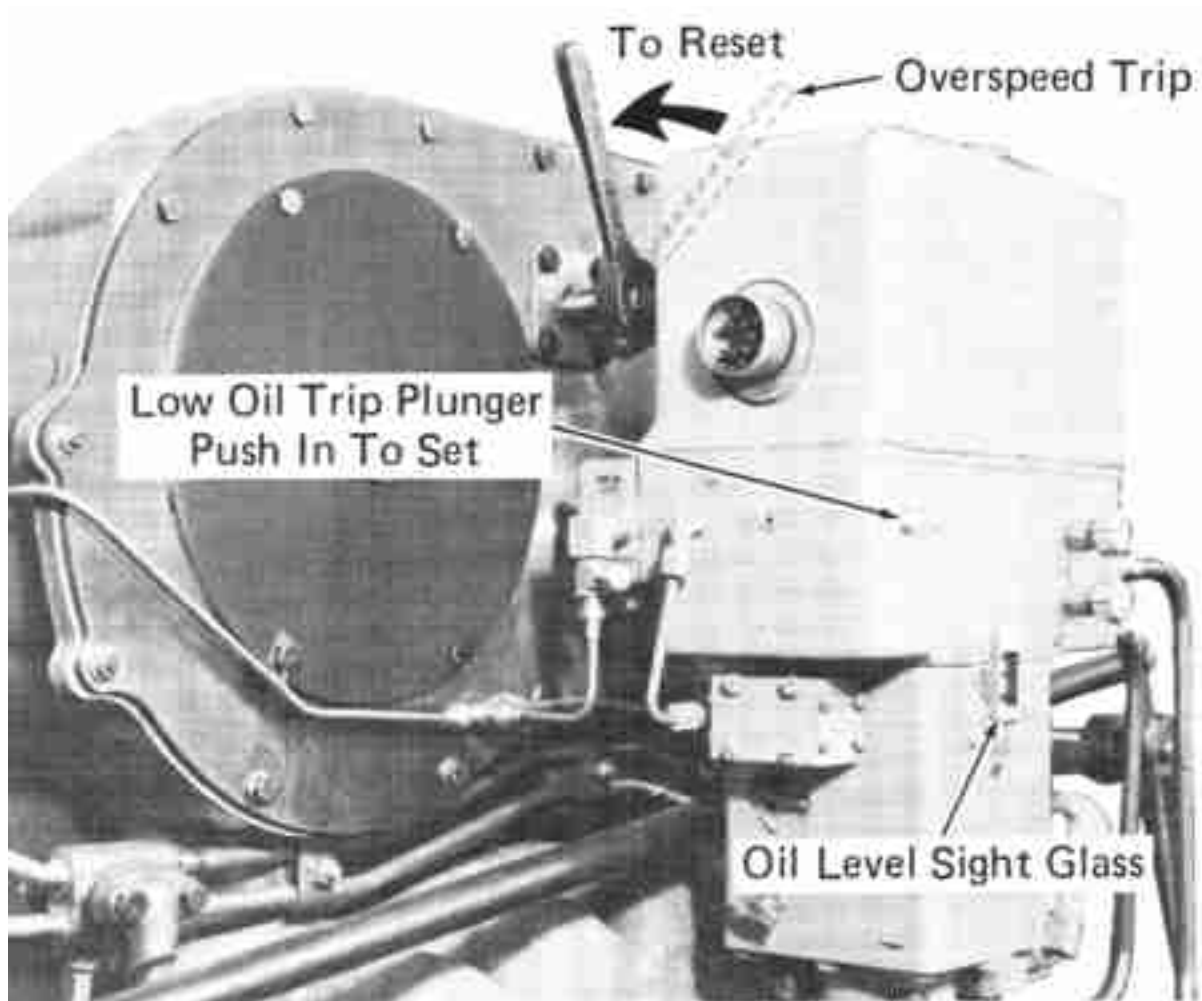

## **STARTING THE DIESEL ENGINE**

After the preceding inspections have been completed, the diesel engine may be started. Starting controls are located at the accessory end of the engine in the area of the equipment rack. See Fig. 2-1.

Perform the following:

NOTE: If engine temperature is 50 deg F or less, preheat the engine before attempting to start.

1. Check oil levels in the engine governor and air compressor. Check engine coolant level. Open the square cover of the engine oil strainer and make certain that the strainer housing is full of oil.
2. Open cylinder test cocks and bar over the engine at least one revolution; observe for leakage from test cocks. Close the test cocks.

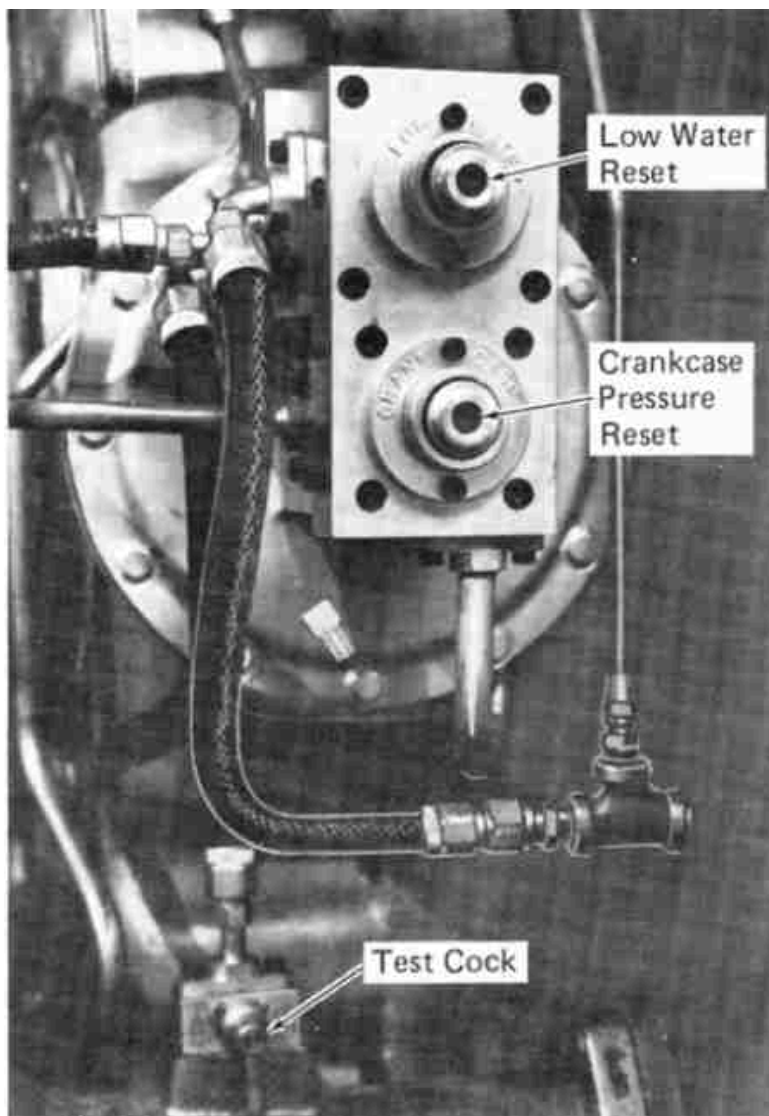

**Fig. 3-2 - Differential Low Water And Crankcase (Oil Pan) Pressure Detector**

3. Check that all fuses are installed and in good condition.

**CAUTION:**

Make certain that the starting fuse is the correct rating as indicated on the panel.

4. Verify that the main battery switch is closed, and that the ground relay switch is closed.

5. Check that all circuit breakers in the black area of the circuit breaker panel are in the on (up) position.

6. Check that the control and fuel pump switch on the control stand is in the (up) position.

7. Check that generator field and engine run switches are in the off (down) position.

8. Check that the isolation switch on the engine control panel is in the START position.

9. At the equipment rack in the engine room, place the Fuel Prime/Engine Start switch in the PRIME position until fuel flows in the return fuel sight glass clear and free of bubbles (normally 10 to 15 seconds). See Fig. 3-3.

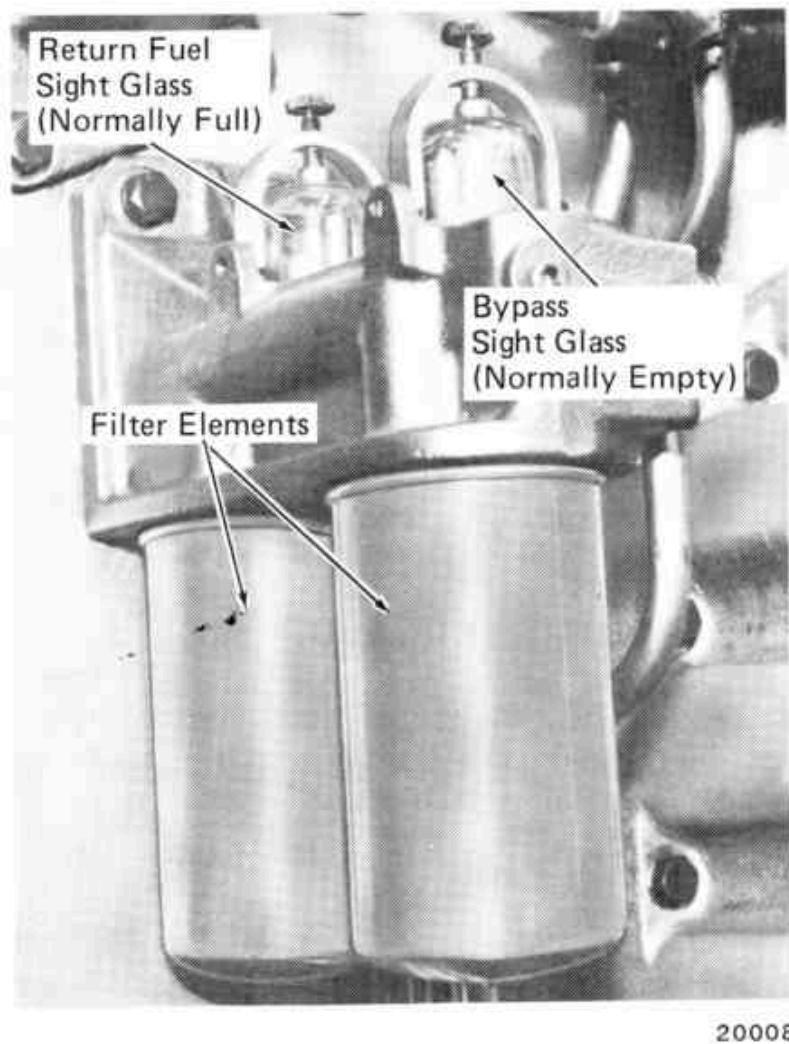

**Fig. 3-3 -- Fuel Oil Sight Glasses**

**CAUTION:**

If engine is equipped with purge control system, do not push injector rack control lever (layshaft) until engine has cranked for six seconds.

10. Position the injector rack manual control lever at about one-third rack (about 1.6 on the scale), then move the Fuel Prime/Engine Start switch to the START position (not more than 20 seconds). Hold the switch in the START position until the engine fires and speed increases.

11. Release the injector control lever when the engine comes up to idle speed. Do not advance lever to increase engine speed until oil pressure is confirmed.

12. Check the low water reset button within 50 seconds after engine start. The low water detector will often trip during engine starting, especially on starting after filling a completely drained system. It may also trip after starting a cold engine or one that has had cooling system pressure released. The detector should be reset soon after the engine starts and is idling, or else the engine will shut down after a time delay established by the engine governor.

**NOTE:**

If the detector is difficult to reset after engine start, position the injector control lever to increase engine speed for a short time, then press the reset button.

The reset button on some detectors will not latch in when the engine is shut down. If such a condition exists, the detector will probably function correctly if it can be reset after engine start.

13. Check that cooling water level, lube oil pressure, and governor oil level are satisfactory.

## **TRAILING UNIT CAB INSPECTION**

Switches, circuit breakers, and control equipment located in the cab of a trailing unit should be checked for proper positioning as follows:

### **Fuse And Switch Panel**

1. All switches closed.
2. Fuses installed and in good condition.

### **Circuit Breaker Panel**

1. All circuit breakers in the black area of the circuit breaker panel in the on (up) position.
2. Other circuit breakers on as required.

### **Engine Control Panel**

1. Isolation switch in START position, and headlight control switch in position to correspond with unit position in consist.
2. Locked wheel cutout and reset switch (if provided) in LOCKED WHEEL (up) position.
3. Dynamic brake cutout switch (if provided) positioned according to railroad operating procedures for trailing units.
4. Traction motor cutout switch (if provided) normally in the MOTORS ALL IN position.
5. Other switches may be placed on as needed. Locomotive Controller

The controller switches and operating handles should be positioned as follows:

1. Control and fuel pump switch, generator field switch, and engine run switch must be off.
2. Throttle in IDLE.
3. Dynamic brake handle in OFF position.
4. Reverser handle placed in neutral and then removed from the controller to lock the other handles.

### **Air Brakes -- Type 26L**

1. Place automatic brake valve handle in HANDLE OFF position. Remove handle (if so equipped).
2. Place independent brake valve handle in FULL RELEASE position. Remove handle (if so equipped).
3. Place MU valve in desired position for trailing unit operation.
4. Place cut-off valve in OUT position.

## **STARTING TRAILING UNIT DIESEL ENGINES**

Engines in trailing units are started in the same manner as the engine in the lead unit. However, if control jumper cables are already connected between units, ensure that the engine run and the control and fuel pump switches in trailing units are off (down).

## **PLACING UNITS ON THE LINE**

After the diesel engines are started and inspected, units may be placed on the line as desired by placing the isolation switch on the engine control panel in the cab in the RUN position. If the consist is at a standstill, be certain that the throttle handle in all units is in the idle position before placing any unit on the line.

## **PRECAUTIONS BEFORE MOVING LOCOMOTIVE**

The following points should be carefully checked before attempting to move the locomotive under its own power:

1. MAKE SURE THAT MAIN RESERVOIR AIR PRESSURE IS NORMAL (approximately 130-140 pounds).

This is very important, since the locomotive is equipped with electro-magnetic switchgear which will function in response to control and permit operation without air pressure for brakes.

2. Check for proper application and release of air brakes.

3. Release hand brake and remove any blocking under the wheels.

### **CAUTION:**

It is desirable that engine water temperatures be 120 deg F. or higher before full load is applied to the engine. After idling at ambient temperature below 0 deg F., increase to full load level should be made gradually.

## **HANDLING LIGHT LOCOMOTIVE**

With the engine started and placed "on-the-line" and the preceding inspections and precautions completed, the locomotive is handled as follows:

1. Place the engine run switch and generator field switch in on (up) position.

2. Place headlight and other lights on as needed.

3. Insert reverser handle and move it to the desired direction of travel, either forward or reverse.

4. Depress safety control foot pedal (if so equipped).

5. Release air brakes.

6. Open throttle to Run 1, 2, or 3 as needed to move locomotive at desired speed.

### **NOTE:**

Locomotive response to throttle movement is almost immediate. There is little delay in power buildup.

7. Throttle should be in IDLE before coming to a dead stop.

8. Reverser handle should be moved to change direction of travel ONLY when locomotive is completely stopped.

## DRAINING AIR RESERVOIRS AND STRAINERS

The air reservoirs and filters should be drained at least once each day whether or not equipment is provided with automatic drain valves. Follow the maintenance schedule established by the railroad.

Drain valves should be operated as follows:

1. Momentarily operate the manual override lever on auxiliary main reservoir centrifugal filter, 2, Fig. 3-4 and Fig. 3-5.

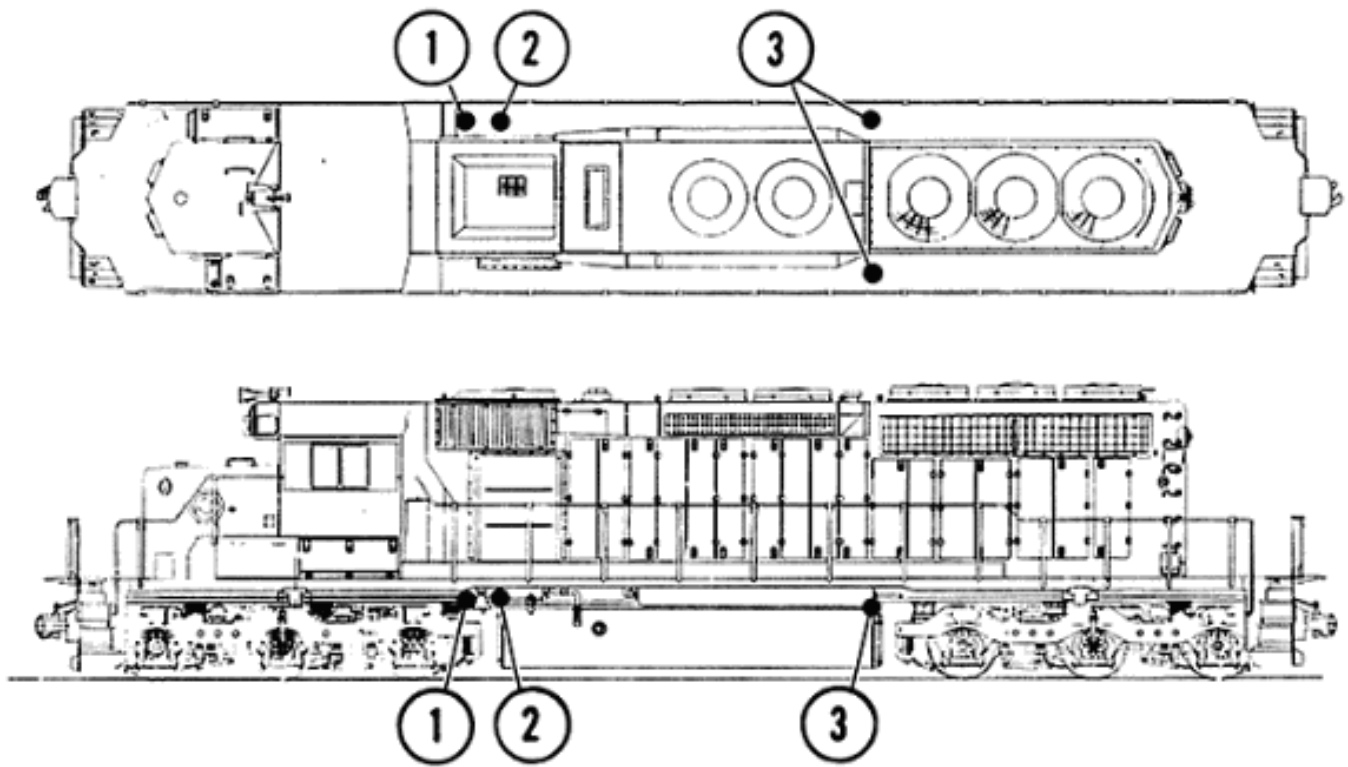

22919

1. Auxiliary Main Reservoir Filter And Drain
2. Main Reservoir Filter And Drain
3. Main Reservoir Drain Valves

**Fig. 3-4 - Compressed Air System Drain Valve Locations**

NOTE: The solenoid drain valve plunger is inoperative when the drain valve solenoid is energized.

2. Momentarily operate the manual override lever on the main reservoir centrifugal filter, 1, Fig. 3-4 and Fig. 3-5.
3. Momentarily open the main reservoir drain valves, 3, Fig. 3-4. 20772

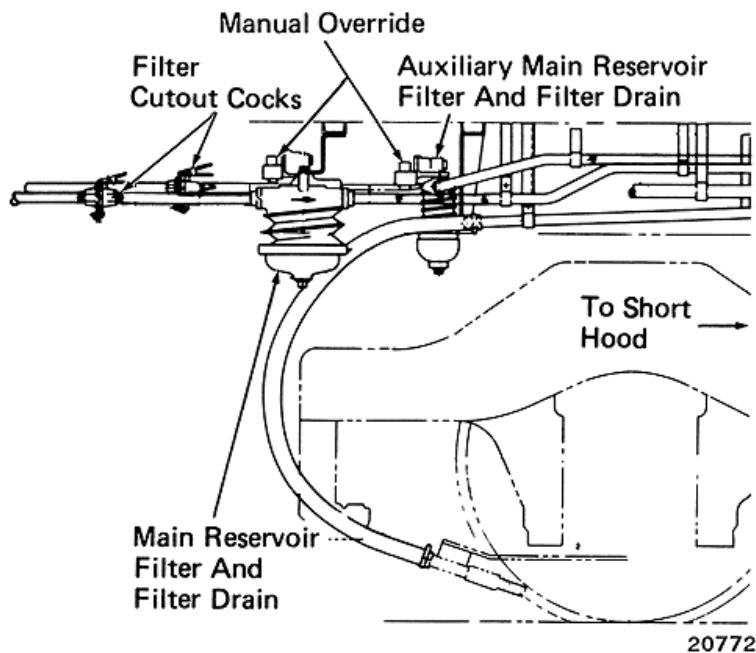

## ENGINE AIR BOX DRAIN

A metal casting mounted on the front end plate of the engine connects drain pipes from each side of the airbox to a common drain pipe. Pressures in opposition at the casting restrict airflow to a permissible amount, yet allow elimination of airbox contaminants. The system is completely automatic and requires no attention by the locomotive operator.

## REMOTE TRACTION MOTOR CUTOUT SWITCH

On locomotives equipped with remote panel mounted traction motor cutout switches, the panel instructions adjacent to the switch must be followed exactly when a traction motor is to be cut out. The cutout switch can not be turned unless the unit is isolated and the local control circuit breaker is closed. Make certain that *all wheels rotate freely* before operating with a motor or motors cut out.

## COUPLING LOCOMOTIVE UNITS TOGETHER

When coupling units together for multiple unit operation, the procedure below should be followed:

1. Remove reverser handles from all trailing units to lock the controls.
2. Couple and stretch units to ensure couplers are locked.
3. Install control cable between units.

### NOTE:

If the consist is made up with older units that are equipped only for pneumatic control of sanding, connect actuating pipes between all units in the consist.

4. Attach platform safety chains between units.
5. Perform ground, engineroom, and engine inspections as outlined in preceding articles.
6. Position cab controls for trailing unit operation as outlined in preceding articles.
7. Connect air brake hoses between units.
8. Open required air hose cutout cocks on both units.

## **COUPLING LOCOMOTIVE UNITS TOGETHER FOR DYNAMIC BRAKING IN MIXED CONSISTS**

The locomotive, when equipped with basic dynamic brakes, makes use of electrical potential from the brake control rheostat to control braking strength by controlling excitation of the main generator field. This electrical potential is impressed upon a trainlined wire to control dynamic braking strength of all units in a consist equipped with potential line brake control. However, the total braking effort of a multi-unit consist can become quite high. Carefully observe railroad rules regarding multiple unit dynamic braking in critical service.

## **COUPLING LOCOMOTIVE TO TRAIN**

Locomotive should be coupled to train using the same care taken when coupling units together. After coupling, make the following checks:

1. Test to see that couplers are locked by stretching connection.
2. Connect air brake hoses.
3. Slowly open air valves on locomotive and train to cut in brakes.
4. Pump up air if necessary, using the following procedure.

## **PUMPING UP AIR**

After cutting in air brakes on train, note the reaction of the main reservoir air gauge. If pressure falls below trainline pressure, pump up air as follows:

1. Place generator field switch in off (down) position.
2. Move reverser handle to neutral position.
3. Open throttle as needed to speed up engine and thus increase air compressor output.

### **NOTE:**

Throttle may be advanced to No. 5 if necessary. Engine should not, however, be run unloaded (as in pumping air) at speeds beyond throttle No. 5 position.

## **BRAKE PIPE LEAKAGE TEST**

Prior to operating the 26L brake equipment, a leakage test must be performed. Brake pipe leakage tests should be made in accordance with the railroad operating rules and Power Brake Law.



## STARTING A TRAIN

The method to be used in starting a train depends upon many factors such as, the type of locomotive being used; the type, weight and length of the train and amount of slack in the train; as well as the weather, grade and track conditions. Since all of these factors are variable, specific train starting instructions cannot be provided and it will therefore be up to the operator to use good judgment in properly applying the power to suit requirements. There are, however, certain general considerations that should be observed. They are discussed in the following paragraphs.

A basic characteristic of the diesel locomotive is its **HIGH STARTING TRACTIVE EFFORT**, which makes it imperative that the air brakes be completely released before any attempt is made to start a train. On an average 100 car freight train having uniformly distributed leakage, it may take 10 minutes or more to completely release the brakes after a reduction has been made. It is therefore important that sufficient time be allowed after stopping, or otherwise applying brakes, to allow them to be fully released before attempting to start the train. The locomotive possesses sufficiently high tractive effort to enable it to start most trains without taking slack. The practice of taking slack indiscriminately should thus be avoided. There will, however, be instances in which it is advisable (and sometimes necessary) to take slack in starting a train. Care should be taken in such cases to prevent excessive locomotive acceleration which will cause undue shock to draft gear and couplers, and lading.

Proper throttle handling is important when starting trains, since it has a direct bearing on the power being developed. As the throttle is advanced, a power increase occurs almost immediately, and power applied is at a value dependent upon throttle position. It is therefore advisable to advance the throttle one notch at a time when starting a train. A train should be started in as low a throttle position as possible, thus keeping the speed of the locomotive at a minimum until all slack has been removed and the train completely stretched. Sometimes it is advisable to reduce the throttle a notch or two at the moment the locomotive begins to move in order to prevent stretching slack too quickly or to avoid slipping.

When ready to start, the following general procedure is recommended:

1. Move reverser handle to the desired direction, either forward or reverse.
2. Place engine run and generator field switches in the on (up) position.
3. Release both automatic and independent air brakes.
4. Open the throttle one notch every few seconds as follows:
  - a. To No. 1 - The engine will quickly load, but the loading will stop at a specific low value. This may be noted on the load indicating meter. At an easy starting place the locomotive may start the train.  
NOTE: The design of the locomotive power control system makes it generally unnecessary to apply locomotive independent brakes or to manipulate the throttle between No. 1 and Idle during starting.
  - b. To No. 2, 3, or higher (experience and the demands of the schedule will determine this) until the locomotive moves.
5. Reduce throttle one or more notches if acceleration is too rapid.
6. After the train is stretched, advance throttle as desired.

### NOTE:

When operating at full throttle to climb a hill or to accelerate, the wheel slip control system reacts so rapidly to correct minor slips by means of Power reduction and sanding that the wheel slip light seldom comes on to indicate severe slips. This wheel slip corrective action is often seen at the load current indicating meter as a steady reduction of load current below that which is normally expected at full throttle for a given speed. Do not misinterpret this power reduction as a fault. It is merely the wheel slip control system doing its job and maintaining power at a level within the adhesion conditions established by track and grade.

## **ACCELERATING A TRAIN**

After the train has been started, the throttle can be advanced as rapidly as desired to accelerate the train.

The speed with which the throttle is advanced depends upon demands of the schedule and the type of locomotive and train involved. In general, however, advancing the throttle one notch at a time is desired to prevent slipping.

The load indicating meter provides the best guide for throttle handling when accelerating a train. By observing this meter it will be noted that the pointer moves toward the right (increased amperage) as the throttle is advanced. As soon as the increased power is absorbed, the meter pointer begins moving toward the left. At that time, the throttle may again be advanced. Thus for maximum acceleration without slipping, the throttle should be advanced one notch each time the meter pointer begins moving toward the left until full power is reached in throttle position 8.

## **AIR BRAKING WITH POWER**

The method of handling the air brake equipment is left to the discretion of the individual railroad. However, when braking with power, it must be remembered that for any given throttle position, the draw bar pull rapidly increases as the train speed decreases. This pull might become great enough to part the train unless the throttle is reduced as the train speed decreases. Since the pull of the locomotive is indicated by the amperage on the load meter, the operator can maintain a constant pull on the train during a slow down, by keeping a steady amperage on the load meter. This is accomplished by reducing the throttle a notch whenever the amperage starts to increase. It is recommended that the independent brakes be kept fully released during power braking. The throttle **MUST** be in Idle before the locomotive comes to a stop.

## **POWER AT STALL**

Do not hold the train at standstill on a grade or with the brakes applied and the throttle open for power. Extensive damage to the traction motors is possible.

## **OPERATING OVER RAIL CROSSING**

When operating the locomotive at speeds exceeding 25 MPH, reduce the throttle to No. 4 position at least eight seconds before the locomotive reaches a rail crossing. If the locomotive is operating in Run 4 position or lower, or running less than 25 MPH, allow the same interval and place the throttle in the next lower position. Advance the throttle after all units of the consist have passed over the crossing. This procedure is necessary to ensure decay of motor and generator voltage to a safe level before the mechanical shock that occurs at rail crossings is transmitted to the motor brushes.

## **RUNNING THROUGH WATER**

Under **ABSOLUTELY NO CIRCUMSTANCES** should the locomotive be operated through water deep enough to touch the bottom of the traction motors. Water any deeper than 3" above the rail is likely to cause traction motor damage.

When passing through any water on the rails, exercise every precaution under such circumstances and always go very slowly, never exceeding 2 to 3 MPH.

## **WHEEL SLIP CORRECTION**

Instantaneous reduction of locomotive power together with automatic sanding functions to correct wheel slip. After adhesion is regained, a timed application of sand continues while power is smoothly restored. The system functions entirely automatically, and no action is required by the locomotive operator.

Depending upon the seriousness of the slipping condition, the wheel slip light may or may not flash on and off as the wheel slip control system functions to correct the slips. However, the wheel slip control system reacts so rapidly to correct minor slips that the wheel slip light seldom comes on to indicate severe slips. The wheel corrective action is often seen at the load current indicating meter as a steady reduction of load current below that which is normally expected at full throttle for a given speed. Do not misinterpret this power reduction as a fault. It is simply the wheel slip control system doing its job and maintaining power at a level within the adhesion conditions established by track and grade.

### **NOTE:**

Whenever possible, operation on grades should be at full throttle position. Throttle reduction during wheel slip is recommended only when:

1. Repeated wheel slip conditions cause severe lurching that may pull a train apart. (Such severe conditions may indicate the need for a helper or the need to take the train up the hill in two parts.)
2. In unusual conditions, simultaneous wheel slips may be incurred at low speed or stall. In this situation the performance of the equipment is directly related to the skill and judgment of the operator. Therefore, the operator must determine to apply sand to the rail and/or reduce throttle.

## **WHEEL SLIP LIGHT**

If the wheel slip light blinks on and off persistently or burns continuously during locomotive operation, a pair of wheels may be sliding or circuit difficulty may exist. Due to the seriousness of sliding wheels, under such indications the locomotive should be **IMMEDIATELY STOPPED** and an investigation made to determine the cause. The wheels may be sliding due to a locked brake, damaged traction motor bearings, or broken pinion or gear teeth.

Repeated ground relay tripping, accompanied by unusual noises such as thumping or squealing, may also indicate serious traction motor trouble that should be investigated at once.

Do not allow any unit that must be isolated due to repeated wheel slip or ground relay action to remain in a locomotive consist **UNLESS IT HAS BEEN ABSOLUTELY DETERMINED THAT ALL OF ITS WHEELS ROTATE FREELY.**

## **LOCK WHEEL LIGHT (On Locomotives So Equipped)**

If the locked wheel and wheel slip lights come on and burn continuously, accompanied by the alarm bell, a locked wheel condition exists. Follow the locked wheel instructions located within the cab.

## **LOCOMOTIVE SPEED LIMIT**

The maximum speed at which the locomotive can be safely operated is determined by the gear ratio. This ratio is expressed as a double number such as 62:15. The 62 indicates the number of teeth on the axle gear while the 15 represents the number of teeth on the traction motor pinion gear.

Since the two gears are meshed together, it can be seen that for this particular ratio the motor armature turns approximately four times for a single revolution of the driving wheels. The locomotive speed limit is therefore determined by the maximum permissible rotation speed of the motor armature. Exceeding this maximum could result in serious damage to the traction motors.

Various gear ratios are available to suit specific locomotive operating requirements. For each gear ratio, there is a maximum operating speed. This information is given in the "General Data" section at the beginning of this manual.

Although not basically applied, overspeed protective equipment is available for installation on locomotives. The equipment consists of an electro-pneumatic arrangement with many possible variations to suit specific requirements. In general, however, an electrical switch in the speed recorder is used to detect the overspeed. This switch in turn initiates certain air brake functions which reduce the train speed.

## **MIXED GEAR RATIO OPERATION**

If the units of the consist are of different gear ratios, the locomotive should not be operated at speeds in excess of that recommended for the unit having the lowest maximum permissible speed. Similarly, operation should never be slower than the minimum continuous speed (or maximum motor amperage) for units having established short time ratings.

To obtain a maximum tonnage rating for any single application, Electro-Motive will, upon request, analyze the actual operation and make specific tonnage rating recommendations.

## **DYNAMIC BRAKING**

Dynamic braking, on locomotives so equipped, can prove extremely valuable in retarding train speed in many phases of locomotive operation. It is particularly valuable while descending grades, thus reducing the necessity for using air brakes.

Depending on locomotive gear ratio, the maximum braking strength is obtained between 19 and 23 MPH. At train speeds higher than the optimum, braking effectiveness gradually declines as speed increases. For this reason, it is important that dynamic braking be started BEFORE train speed becomes excessive. While in dynamic braking, the speed of the train should not be allowed to "creep" up by careless handling of the brake.

To operate dynamic brakes, proceed as follows:

1. The reverser handle must be positioned in the direction of the locomotive movement.

2. Return throttle to Idle and hold it in Idle for 10 seconds before proceeding.

**WARNING:**

The 10 second delay must be accomplished before the braking handle is moved into SET UP position.

On locomotives delivered after December, 1969, braking delay occurs automatically. Do not misinterpret the delay as failure of the dynamic braking system.

It is possible for a sudden surge of braking effort to occur if the dynamic braking handle is open when the automatic delay times out.

3. Move the braking handle into SET UP position. This establishes the dynamic braking circuits. It will also be noted that a slight amount of braking effort occurs, as evidenced by the load current indicating meter.

4. After the slack is bunched, the dynamic braking handle is moved to control dynamic braking strength. As it is advanced out of SET UP, it will be noted that the engine speed automatically increases.

5. Braking effort may be increased by slowly advancing the handle to FULL 8 position if desired. Maximum braking current, limited to 700 amperes can occur over a wide range of braking handle positions. This range allows braking effort increase as train speed increases. The tendency is to hold train speed relatively constant for a given braking handle position when conditions result in less than the maximum allowable current.

**NOTE:**

On units equipped for "Grid Current Trainline Control" of dynamic braking, maximum current is limited by braking handle position, with 700 -amperes obtainable only with braking handle in the maximum position. Braking current will generally be at or near the maximum obtainable at the given handle position, and the tendency for train speed to hold steady for a given handle position is not as effective as with the basic brake.

6. With automatic regulation of maximum braking strength, the brake warning light on the controller should seldom given indication of excessive braking current. If the brake warning light does flash on however, movement of the braking handle should be stopped until the light goes out.

7. If the light fails to go out after several seconds, move the braking handle back slowly until the light does go out. After the light goes out, the handle may again be advanced to increase braking effort.

**NOTE:**

The brake warning light circuit is "trainlined" so that a warning will be given in the lead unit if any unit in the consist is generating excessive current in dynamic braking. Thus regardless of the load indicating meter reading or braking handle position (which may be less than maximum), whenever the warning light comes on, it should not be allowed to remain on for any longer than two or three seconds before steps are taken to reduce braking strength.

If brake warning indications are repeated, the locomotive should be taken out of dynamic braking and the dynamic brake cutout switch on the engine control panel of the affected unit should be placed in CUTOFF position. The locomotive consist will then operate normally under power and during dynamic braking, but with reduced total braking effort.

8. When necessary, the automatic brake may be used in conjunction with the dynamic brake. However, the independent brake must be KEPT FULLY RELEASED whenever the dynamic brake is in use, or the wheels may slide. As the speed decreases below 10 MPH the basic dynamic brake becomes less effective. When the speed further decreases, it is permissible to completely release the dynamic brake by placing the handle in OFF position, applying the independent brake simultaneously to prevent the slack from running out.

The locomotive can be operated in dynamic braking when coupled to older units that are not equipped with brake current limiting regulators. If all the units are of the same gear ratio, the unit having the lowest maximum brake current rating should be placed as the lead unit in the consist. The operator can then operate and control the braking effort up to the limit of the unit having the lowest brake current rating, without overloading the dynamic brake system of a trailing unit. The locomotive consist MUST always be operated so as not to exceed the braking current of the unit having the lowest maximum brake current rating.

Units equipped with dynamic brake current limiting regulators can be operated in multiple with other locomotives in dynamic braking regardless of the gear ratio or difference in the maximum brake current ratings

## **DYNAMIC BRAKE WHEEL SLIP CONTROL**

During dynamic braking, each series group of two traction motors is connected in parallel with each dynamic braking resistor grid circuit and with the other series connected traction motors. With this arrangement, when a wheel slips it may be motored by other motors in the system. This in effect makes a wheel slip during dynamic braking somewhat self correcting. However, the parallel arrangement of dynamic braking resistor grids and traction motors is such that the full response of the wheel slip control system is available during dynamic braking as well as during power operation. The precise and immediate regulation maintained, plus the motoring effect created by the parallel arrangement, provides extremely stable dynamic brake operation.

In addition to the above, a bridge circuit is employed to protect against the possibility of simultaneous slips that otherwise may not be detected.

When a pair of wheels is detected tending to rotate at a slower speed, the retarding effort of the traction motors in the unit affected is reduced (traction alternator field excitation is reduced in the unit affected) and sand is automatically applied to the rails. When the retarding effort of the traction motors in the unit is reduced, the tendency of the wheel set to rotate at a slower speed is overcome. After the wheel set resumes normal rotation, the retarding effort of the traction motors returns (increases) to its former value. Automatic sanding continues for 3 to 5 seconds after the wheel slide tendency is corrected.

## **DOUBLE HEADING**

Prior to double heading behind another locomotive, make a full service brake pipe reduction with the automatic brake valve, and place the cut-off valve in OUT position. Return the automatic brake valve handle to the release position and place the independent brake valve in release position. On 26L equipment place the MU valve in LEAD position.

The operation of the throttle is normal, but the brakes are controlled from the lead locomotive. An emergency air brake application may be made, however, from the automatic brake valve of the second unit. Also, the brakes on this unit may be released by depressing the independent brake valve handle while it is in the release position.

## **OPERATION IN HELPER SERVICE**

Basically, there is no difference in the instructions for operating the locomotive as a helper or with a helper. In most instances it is desirable to get over a grade in the shortest possible time. Thus, wherever possible, operation on the grades should be in the full throttle position. The throttle can be reduced, however, where wheel slips cause lurching that may threaten to break the train.

## **ISOLATING A UNIT**

When the occasion arises where it becomes advisable to isolate a locomotive unit, observe the following:

1. When operating under power, a unit may be isolated at any time, but discretion as to timing and necessity should be used.
2. When operating in dynamic braking, it is important to get out of dynamic braking before attempting to isolate the unit. This is done by reducing the braking handle to OFF. The isolation switch can then be moved to START position to eliminate the braking on that unit. If the braking is resumed, other units will function normally.

## **CHANGING OPERATING ENDS**

When the locomotive consist includes two or more units with operating controls, the following procedure is recommended in changing from one operating end to the opposite end on locomotives equipped with 26L brakes.

### **ON END BEING CUT OUT**

1. Move the automatic brake valve handle to service position and make a 20-pound reduction.
2. After brake pipe exhaust stops, place cut-off valve in OUT position by pushing dial indicator handle in and turning to the desired position.
3. Place independent brake in fully released position.
4. Place MU valve in the desired TRAIL position, depending on brake equipment on trailing units. (MU valve is located on the left hand side of the air pedestal. Push dial indicator inward and turn to desired position.)
5. Position automatic brake valve in handle off position. (Handle may be removed if so equipped.)
6. Place dynamic brake handle in OFF position and throttle in IDLE.
7. Place reverser handle in neutral position and remove to lock controller.
8. At the controller, place all switches in the off (down) position. Be absolutely certain that the control and fuel pump switch, generator field switch, and engine run switch are in the off (down) position.
9. At the engine control panel, place headlight control switch in proper position for trailing unit operation. Place other switches ON as needed.
10. At the circuit breaker panel, all circuit breakers in the black area are to remain in the ON position.
11. After completing the operations outlined in the preceding steps, move to the cab of the new lead unit.

### **ON END BEING CUT IN**

1. At the controller, make certain the generator field switch is off (down).
2. Insert reverser handle and leave in neutral position.
3. Insert automatic brake valve handle (if removed) and place in suppression position to nullify any safety control, overspeed, or train control used.
4. Insert independent brake valve handle (if removed) and move handle to full independent application position.
5. Position cutoff valve in either FRT or PASS position depending on make up of the train.
6. Place MU valve in LEAD position.
7. At the circuit breaker panel, check that all circuit breakers in the black area are in the ON position.
8. At the engine control panel, place the headlight control switch in proper position, and other switches ON as needed.
9. At the controller, place the engine run, control and fuel pump, and generator field switch in on (up) position. Other switches may be placed on as needed.

## STOPPING ENGINE

There are six ways to stop the engine.

1. Press stop button on engine control panel.

When the locomotive is standing still or under power, the isolation switch should be placed in STOP position. The stop button can then be pressed in to stop the engine. Since the reaction of the stop button is instantaneous, it need not be held in.

2. Press emergency fuel cutoff button.

Emergency fuel cutoff pushbuttons are located near each fuel filter opening and on the engine control panel. These pushbuttons operate in the same manner as the STOP button and need not be held in nor reset.

3. Use injector rack manual control lever.

The injector control lever at the accessory end of the engine can be operated to override the engine governor and move the injector racks to the no fuel position.

4. Close the low water detector test cock.

When the low water detector- trips, oil is dumped from the governor low oil shutdown device, stopping the engine.

5. Use throttle handle.

To stop all engines "on the line" in a consist simultaneously from the cab of the lead unit, move the throttle to the IDLE position, pull the lever out and away from the controller, and move it beyond IDLE to the STOP position.

6. Pull out low oil shutdown plunger on the side of the governor.

NOTE: Observe freezing weather precautions whenever an engine is shut down during cold weather.

## FREEZING WEATHER PRECAUTIONS

As long as the diesel engine is running, the cooling system will be kept adequately warm regardless of ambient (outside) temperatures encountered. It is only when the engine is shut down or stops for any reason that the cooling system requires protection against freezing.

When danger of freezing is present, the cooling system should be completely drained or have steam admitted. The basic valves are illustrated in Fig. 3-6.

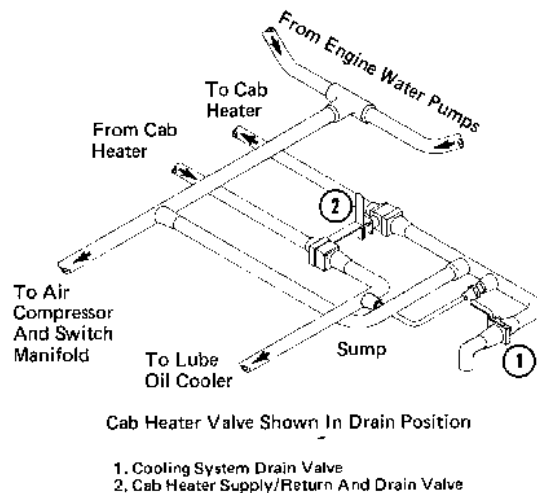



## Oil Cooler Cab Heater Valve Shown In Drain Position

1. Cooling System Drain Valve
2. Cab Heater Supply/Return And Drain Valve

**Fig.3-6 - Engine And Cab Heater Drain Valve Locations**

## **DRAINING THE COOLING SYSTEM**

The engine cooling system should be drained in the event that the diesel engine is stopped and danger of freezing exists. The draining procedure is as follows:

### Drain Engine Cooling And Cab Heater System

Make sure that the following valves are open.

1. Cab heater supply and return valve.
2. Engine water drain.

The above valves are located in engine drain sump, governor end of engine.

3. Preheater water supply (located at equipment rack, if so equipped).
4. Preheater water return (located at equipment rack, if so equipped).

All valves are tagged as noted and open when handles are in line with piping.

After system pressure is released, remove the water tank fill cap, Fig. 3-7, to allow drainage at an increased rate.

## **COOLING SYSTEM**

**FOR NORMAL FILLING - DO NOT REMOVE PRESSURE CAP. ATTACH HOSE AT FILL CONNECTOR AND HOLD FILL VALVE OPEN.**

**CAUTION - IF PRESSURE CAP MUST BE REMOVED, DO NOT ATTACH HOSE TO FILL PIPE. HOLD FILL VALVE OPEN UNTIL TANK IS COMPLETELY VENTED. THEN REMOVE CAR WHEN REPLACING, HOLD FILL VALVE OPEN SO CAP CAN BE FULLY TIGHTENED AS SHOWN.**

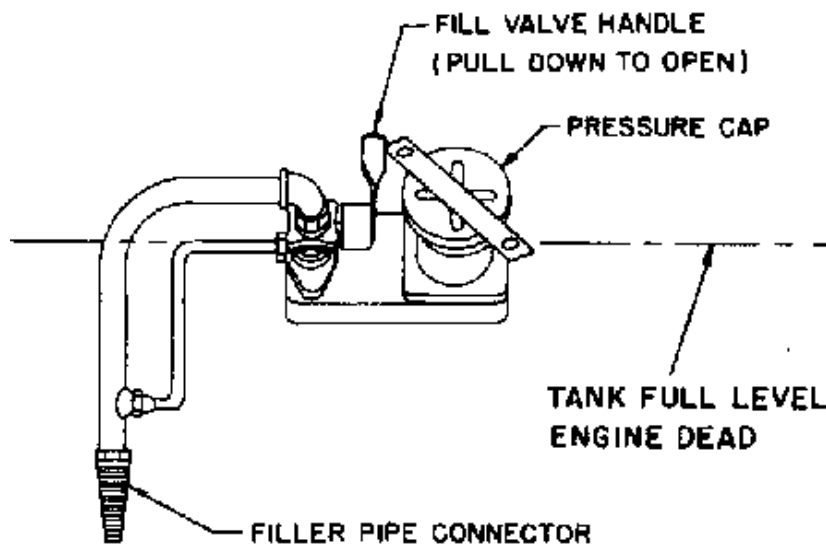

### **CAUTION:**

If a hot engine is drained, always allow the engine to cool before refilling with fresh coolant.

#### **Drain Cab Heater System, Only**

1. Place cab heater supply and return valve in drain (handle vertical) position.
2. Engine water drain valve is to remain closed.

#### **Drain Flush Toilet (if So Equipped)**

1. Flush toilet until all water has drained from tank.
2. Turn off electric toilet tank heater (if so equipped).
3. Remove pipe plug from bottom of toilet flush piping.

#### **Drain Water Cooler (if So Equipped)**

1. Remove and empty water bottle.
2. Drain remaining water in cooler by holding in the spigot button.
3. Turn off electric power to water cooler (if so equipped).

### **CAUTION:**

On special order, heater shutoff valves are located in the piping at the cab heaters; these valves must be open when draining the system, and when the locomotive is operating during freezing weather.

On units equipped with special automatic cooling system drain, the automatic water drain circuit breaker must be in the ON position.

It may be necessary to open the automatic water drain circuit breaker when filling a cold system with cold water. Make certain that the breaker is closed after the engine has run long enough to warm the system.

## **TOWING LOCOMOTIVE IN TRAIN**

When a locomotive unit equipped with 26L air brakes is placed within a train consist to be towed, control and air brake equipment should be set as-follows:

1. Drain all air from main reservoirs and- air brake equipment unless engine is to remain idling.
2. Place the MU valve in DEAD position.
3. Place cut-off valve in OUT position.
4. Place independent brake valve handle in release position.
5. Place automatic brake valve handle in handle off position.
6. Cut in dead engine feature by turning cutout cock, Fig. 2-11, to open (90 deg to pipe) position. Dead engine cock is located beneath cab floor and may be reached through an access door of locomotive.
7. If engine is to remain IDLING, switches should be positioned as follows:
  - a. Isolation switch in START position.
  - b. Main battery switch and ground relay cutout switch is closed.
  - c. Generator field circuit breaker OFF.

d. All breakers in black area of circuit breaker panel in ON position.

e. Starting fuse should be removed. Other fuses should be left in place.

f. Control and fuel pump switch on (up).

g. Fuel pump circuit breaker ON.

h. Throttle in IDLE, dynamic brake handle in OFF position. Remove reverser handle from controller to lock the controls.

i. Locked wheel switch (if provided) on engine control panel in LOCKED WHEEL position.

8. If a locomotive equipped with the locked wheel detection system is to be towed DEAD in a consist, observe the same setup as Step 7 above, but drain the cooling system if freezing conditions are possible. This setup is necessary to maintain the locked wheel detection and alarm circuits.

9. If a locomotive not equipped with locked wheel detection system is to be towed DEAD in a consist, switches should be positioned as follows:

- a. Main battery switch open.
- b. All circuit breakers OFF.
- c. All control switches off (down).
- d. Starting fuse removed.
- e. Throttle in IDLE, dynamic brake handle in OFF position. Remove reverser handle from controller to lock the controls.

NOTE: If there is danger of freezing, the engine cooling system should be drained.

## **LEAVING LOCOMOTIVE UNATTENDED**

If at any time it is necessary to leave the locomotive unattended while the engine is running, the following procedure should be adhered to.

1. Observe all railroad safety precautions.

2. Place engine run and generator field switches in the off (down) position.

3. Place throttle in IDLE and dynamic brake handle in OFF position. Remove reverser handle from controller to lock th

## SECTION 4

### TROUBLE SHOOTING

#### INTRODUCTION

This section covers operational problems that may occur on the road and suggests action that may be taken by the operator in response to the trouble.

Safety devices automatically protect equipment in case of faulty operation of almost any component. In general this protection is obtained by one of the following methods.

1. Complete shutdown of the diesel engine, or complete elimination of a function such as dynamic braking.
2. Unloading of the diesel engine and restriction to idle engine speed. In some instances manual re setting of the function may be necessary, or automatic resetting after a time delay may be provided.
3. Rough back-up regulation for protection of Condition equipment.

Condition	Probable Cause	Suggested Operator's Response
Alarm bell rings -- No alarm lights on in lead unit.	Trailing unit hot engine.	No action required unless alarm persists. If alarm continues for more than a few minutes, investigate the cause of the alarm in trailing units.
NOTE: If governor low oil plunger trips to shut the engine down, but the crankcase and low water detector buttons remain set, check oil and water levels. If oil level is satisfactory and water level is marginal, the hot oil detector (on units so equipped) may have tripped. There is no indicator for such a trip except a very hot engine condition. Do not attempt to restart engine. Report engine shutdown circumstances to authorized maintenance personnel.		
	Trailing unit reduced to idle speed and power or shut down.	If trailing unit is equipped with automatic ground relay reset and the ground relay has tripped, it will automatically reset in 10 seconds unless the total number of grounds is excessive.
		If trailing unit is not equipped with automatic ground relay reset, take no action for 10 seconds; then press the ground relay reset pushbutton on the control stand if so equipped.  In any case, if the alarm does not stop within a few minutes, investigate the cause of the alarm in trailing units.
Turbocharger Auxiliary Pump light on.	Normal condition for 35 minutes after engine start or stop.	No action necessary.
Turbocharger Auxiliary Pump light not ON at engine start or stop.	Tripped Turbo Lube pump CB.	Report to maintenance personnel.
Engine will not crank.	Control and Fuel Pump Switch off (down).	Switch on (up).
H.V. GRD./FAULT light on. Alarm bell rings.	Traction motor flashover.	After 10 seconds, press the ground relay reset button on the control stand if so equipped. The light will go out and power will be restored. This will occur automatically on units so equipped.
	High voltage path to ground due to moisture or insulation failure.	Same response as above. If ground relay trip repeats only at high speed, temporary operation at lower throttle position may help to dry out the grounding circuit.
NO BATT. CHARGE/ NO POWER light on or battery charging indicator (if so equipped) shows discharge with engine running. Engine will shut down from lack of fuel.	Tripped breaker or blown fuse. Engine shut down.	Isolate the unit. Check for - 1. Tripped circuit breaker. 2. Blown fuse. 3. Engine overspeed trip.  Test and replace fuses as necessary, or reset circuit breaker. Reset engine overspeed trip lever if required. Restart engine and reapply power.  If fuses again blow or breakers trip, shut down and isolate the unit.  If overspeed trip again occurs, operation at lower throttle position may prevent further tripping.
HOT ENGINE light on; alarm ringing; engine speed and power reduced on affected unit.  (See note on first troubleshooting page)	Tunnel or desert operation	No action necessary unless alarm continues for more than a few minutes.  If alarm continues, isolate the affected unit. If water level is too low, shut the engine down.  If freezing conditions are possible, drain the cooling system in accordance with railroad regulations.
Full engine speed and power not obtainable. Annunciator ENG. AIR FILT. light will not reset.	Plugged engine air filters.	Operation may continue. Engine speed and power restricted at upper throttle positions. Condition to be reported at first maintenance point.
GOVERNOR SHUTDOWN light on.	Low water due to leak, or low oil due to leak, or crankcase pressure due to cracked piston or bad cylinder seals, or hot oil due to plugged oil cooler.	If shutdown is due to low water, the addition of water may permit continued operation. Otherwise place the isolation switch in ISOLATE position. If freezing conditions are possible drain the cooling system in accordance with the railroad regulations.
WARNING: If crankcase pressure detector has tripped, make no further engineroom inspections. Do not attempt to restart the engine. Isolate the unit. If freezing conditions are possible, drain the cooling system in accordance with railroad regulations.		
Repeated automatic sanding along with load current indicating meter dropping back.	Normal wheel slip correction under severe conditions.	No action required. Do not reduce throttle unless slipping is so severe that lurching threatens to break the train. Condition

Continuous wheel slip light; LOCK WHEEL light; alarm bell and buzzer.	Locked wheel or unequal release of brakes.	<ol style="list-style-type: none"> <li>1. Stop train.</li> <li>2. Look for unit with locked wheel indication.</li> <li>3. Roll train slowly and observe wheels. <ul style="list-style-type: none"> <li>-- a. If wheel slides, cut unit out of train.</li> <li>-- b. If all wheels roll, and locked wheel indication resets automatically, proceed normally. Report locked wheel indication to authorized maintenance personnel.</li> </ul> </li> </ol>
PCS light on.	Penalty brake apphcation	Move throttle to idle. Move brake valve handle to handle off position and then return handle to release position.
	Emergency brake application	Move throttle to idle position. Move brake handle to emergency position and wait 45 seconds before moving handle to release position.
NOTE: Follow railroad regulations after any penalty or emergency brake application.		
Brake Warning Light.	Regulating system failure.	Place dynamic brake cutout switch on engine control panel of affected unit in the CUTOUT position.