

DIESEL LOCOMOTIVE

OPERATING MANUAL

NO. 2315



for
MODELS F9, FP9, FL9

2nd Edition
JULY, 1957

ELECTRO-MOTIVE DIVISION

GENERAL MOTORS CORPORATION

LAGRANGE, ILLINOIS, U.S.A.

INTRODUCTION

The purpose of this manual is to serve as a guide for railroad personnel engaged in the operation of the ELECTRO-MOTIVE 1750 HP F9, FP9 and FL9 locomotives.

The first three sections of the manual present the necessary information to enable the engineman to successfully operate the locomotive "over the road." A general description and location of the component parts is contained in Section 1. Section 2 outlines the recommended procedures to be followed for successful operation of the locomotive equipment. A description and general operation of the most commonly used "extras," including dynamic brakes, is found at the end of Section 2.

Section 3 outlines the possible causes, location, and correction of difficulties that may be encountered while "on the road."

Sections 4 and 5 of the manual have been included for those who desire a more thorough knowledge of the locomotive's Systems and Electrical equipment. Charts and wiring diagrams are used to illustrate the descriptive material.

Principal articles of each section are numbered consecutively for ready reference, as is each page of the section. Articles and pages are numbered in the 100 series type of numbering. A page in the 400's is in Section 4 as is any article numbered in the 400's.

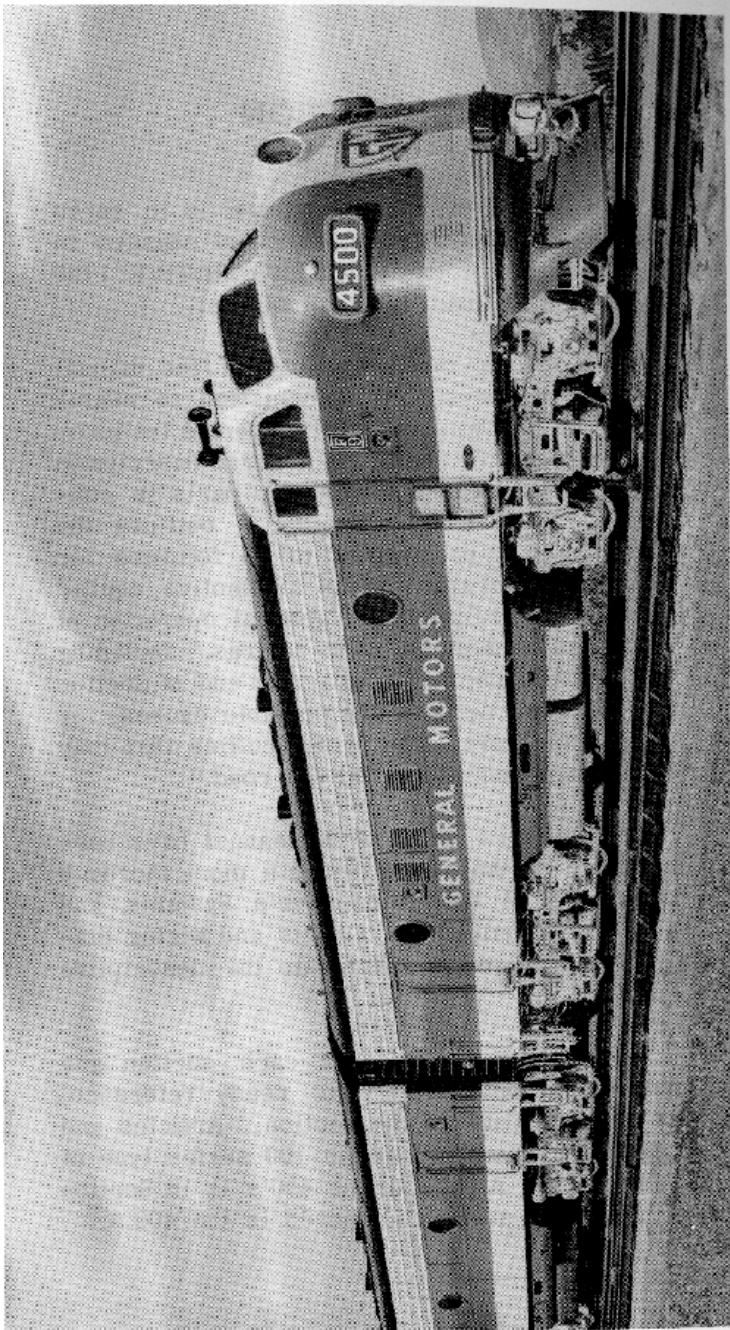

GENERAL DATA

F9, FP9 AND FL9 DIESEL LOCOMOTIVES

Weight (fully loaded)	F9A Unit (approx.)...	230,000 lbs.
	FP9A Unit (approx.) .	258,000 lbs.
	F9B Unit (approx.) .	230,000 lbs.
	FL9A Unit (approx.) .	266,400 lbs.
Fuel Capacity (per unit)		1,200 gal.
Lubricating Oil Capacity (per engine)		200 gal.
Cooling Water Capacity	"A" Unit-"G" Valve.	230 gal.
	"B" Unit-"G" Valve.	215 gal.
Steam Generator Water Capacity (if used):		
Vertical Tank -	FP9A Unit	820 gal.
	F9B Unit	1,200 gal.
	FL9A Unit	1,920 gal.
Hatch Tank -	FP9A Unit	330 gal.
	FL9A Unit	330 gal.
	(Without dynamic brakes, all units may have an additional 600 gal. hatch tank)	
	Tank Under 2750 lb. Steam Generator ...	200 gal.
Gear Ratios and Maximum Speeds:		
65/12.....55 MPH	59/18.....83 MPH	
62/15.....65 MPH	58/19.....89 MPH	
61/16.....71 MPH	57/20.....95 MPH	
60/17.....77 MPH	56/21.....105 MPH	
Sand Capacity (per unit)		16 cubic feet
Number of Drivers (per unit)		4 pair
Wheel Diameter		40"
Weight on Drivers (F9 and FP9)		100%
Weight on Drivers (FL9)(approx.)		213,120 lbs.
Truck Centers (F9)		30' 0"
Truck Centers (FP9 and FL9)		34' 0"
Truck - Rigid Wheelbase (F9, FP9 and #1 Truck FL9)		9' 0"
Truck - Rigid Wheelbase (#2 Truck FL9)		13' 7"

GENERAL DATA (Cont'd)

Minimum Curve Radius (F9 and FP9).....	250'
Minimum Curve Radius (FL-9)	274'
Center of Gravity Above Rail (approx.)	63"
Overall Length Over Coupler F9A Unit	50' 8"
FL9A Unit.....	58' 0"
FP9A Unit	54' 8"
F9B Unit	50' 0"
Maximum Height Above Rail	15' 0"
Maximum Width Over Handholds.....	10' 8"

TABLE OF CONTENTS

	Page
SECTION 1 - DESCRIPTION	100
General Description	100
Diesel Engine	100
Main Generator	101
Alternator	101
Traction Motors	102
Auxiliary Equipment	103
Storage Battery	103
Auxiliary Generator	103
Traction Motor Blowers	103
Radiator Cooling Fans	104
Air Compressor	104
Fuel Pump	105
Operating Controls	105
Throttle Lever	105
Reverse Lever	106
Selector Lever	107
Mechanical Interlocks On The Controller	107
Air Brake Equipment	109
Automatic Brake Valve	109
Independent Brake Valve	110
Rotair Valve	110
Brake Pipe Cutout Cock (Double-Heading Cock)	113
Engineman's Instrument Panel	113
Load Indicating Meter	113
Wheel Slip Light	114
Air Gauges	114
Engineman's Control Panel	115
Circuit Breakers	115
Headlight Control Switch	115
'PC" Switch And Light	116

	Page		Page
Engine Control Panel	117	Handling Locomotive	208
Isolation Switch	117	Precautions Before Moving Locomotive	208
Engine Start And Stop Buttons	118	Handling Light Locomotive	208
Fuel Pump Switch	118	Coupling To Train And Pumping Up Air	209
Electrical Control Cabinet	118	Starting A Train	209
Fuses And Knife Switches	118	Automatic Sanding In Power	212
Ground Relay	120	Acceleration Of A Train	213
Control Air Pressure Regulator	121	Slowing Down Because Of A Grade	213
Emergency Fuel Cutoff Ring	121	Locomotive Operation At Very Slow Speeds	213
Alarm Indications	122	Braking	214
Engine room	122	Air Braking With Power	214
Engine Governor	123	Miscellaneous Operating Instructions	214
Load Regulator	125	Multiple Unit Operation	214
Engine Overspeed Trip	125	Uncoupling And Coupling Units In Locomotive	216
Manual Layshaft	126	Changing Operating Ends	216
Miscellaneous Equipment	126	Handling Locomotive Dead-In-Train	218
Speed Recorder-Locomotive Overspeed Control	126	Doubleheading	219
Hand Brake	126	Operation In Helper Service	219
Manual Sanding Valve	127	Freezing Weather Precautions	220
Classification Lights	127	Operation Over Railroad Crossings	222
Number Box Lights	127	Running Through Water	222
Horn Valves	127	Resetting PC Switch After Safety Control Application	223
Bell Ringer	128	Ground Relay Action	223
Windshield Wipers	128	Wheel Slip Indication	223
Cab Heaters And Defrosters	128	Indication Of A Pair Of Wheels Sliding	224
Trucks	128	Air Box Drains	224
SECTION 2 - OPERATION	200	Operating Of Locomotive "Extras"	225
Basic Information	200	Dynamic Brake Operation	225
When Boarding The Locomotive	200	Dynamic Brake Selector Switch	229
Precautions Before Starting Engine	203	Dynamic Brake Warning Light	230
To Start Engine	204	Dynamic Brake Grid Blower	230
Placing An Engine On The Line	206	Dynamic Brake Wheel Speed Control	230
To Stop Engine	206	Hump Speed Control	231
Securing Locomotive For Layover	207	Motor Lockout Switches	234
		Operating "B" Unit With Hostler's Controls	234
		Safety Control Foot Pedal	235
		Brake Pipe Flow Indicator	235

	Page
SECTION 3 - LOCATION AND CORRECTION OF DIFFICULTIES ON-THE-ROAD	300
General	301
If Alarm Bells Ring	301
Additional Safety Devices	307
Ground Relay	307
"PC" Switch Open	308
Engine Overspeed Trip	308
Fuel Flow	309
Emergency Fuel Cutoff Valve	309
Control Air Pressure	310
Correction Of Difficulties	311
If The Engine Goes To Idle	311
If The Engine Stops	311
How To Start Engine	312
If The Engine Does Not Rotate When "Start" Button Is Pressed	312
If The Engine Rotates But Does Not Start When "Start" Button Is Pressed	313
If The Engine Does Not Speed Up When Throttle Is Opened	313
Engine Speeds Up But Locomotive Does Not Move When Throttle Is Opened	314
Battery Ammeter Shows Continual Discharge	314
Compressor Control	315
Cylinder Test Valves	315
Trouble Shooting Check Chart	317-318
SECTION 4 - COOLING, LUBRICATING OIL, FUEL OIL AND AIR SYSTEMS	400
Cooling System	400
Operating Water Level	402
Filling Cooling System	403
Draining Cooling System	404
Cab Heating	404

	Page
Lubricating Oil System	405
Oil Level	406
Adding Oil To System	406
Oil Pressure	407
Fuel Oil System	407
Fuel Sight Glasses	409
Filling Fuel Tanks	410
Fuel Gauge	410
Emergency Fuel Cutoff Valve	410
Air System	411
Air Compressor	411
Compressor Control	412
Manual Unloader Valve	414
Draining Of Air System	415
SECTION 5 - ELECTRICAL	500
Basic Electrical Systems	500
Main Generator	501
Traction Motors	502
Reverser	504
Transition	504
Transition Control Circuit	506
Load Regulator	508
Engine Speed Control	509
ER Relay	511
Battery Field Contactor And Fuse	511
Wheel Slip Control	512
Main Battery Switch	514
Battery Ammeter	515
Reverse Current Relay	515
Battery Charging Contactor	515
Ground Relay	516
Voltage Regulator	517
Auxiliary Generator Fuse (Battery Charging)	517
Auxiliary Generator Field Fuse	517
Alternator Field Fuse	518
No AC Voltage Relay (NVR)	518
Electrical Circuits	519

SECTION 1

DESCRIPTION

GENERAL DESCRIPTION

A description and general location of equipment on F9 (Fig. 1-1), FP9 and FL9 locomotives is given in this section.

A locomotive consists of one or more units rated at 1750 horsepower per unit. Those units equipped with an operating cab are designated "A" units, and those without cabs as "B" or Booster units. Depending upon the horsepower requirements a locomotive will consist of from 1 to 4 units. The FP9 and FL9 locomotives are only built as "A" units and are exactly comparable to the F9 "A" units except that the FP9 is 4 feet longer than the F9 and the FL9 is 4 feet longer than the FP9, to provide space for additional features or equipment. The FL9 also differs from the F9 and FP9 in that it is equipped with a six wheel #2 truck.

100 Diesel Engine The main generator and auxiliaries of these units are driven by a 16-cylinder V-type, 2 cycle, 1750 HP Model 567C Diesel engine, Fig. 1-2. The cylinders have an 8-1/2" bore and a 10" stroke. The two banks of the engine are arranged with respect to each other at an angle of 45°. The engine has a fully scavenging air system and has two blowers for this purpose. The blowers are mounted on the rear end of the engine; each blower is equipped with a separate air filter.

The engine is started by temporarily using the direct coupled main generator as a starting motor. Current from a storage battery "motors" the main generator to rotate the engine.

NOTE: In this manual, the word "engine" refers specifically to the Diesel engine; the word "locomotive" refers to a consist of one or more units.

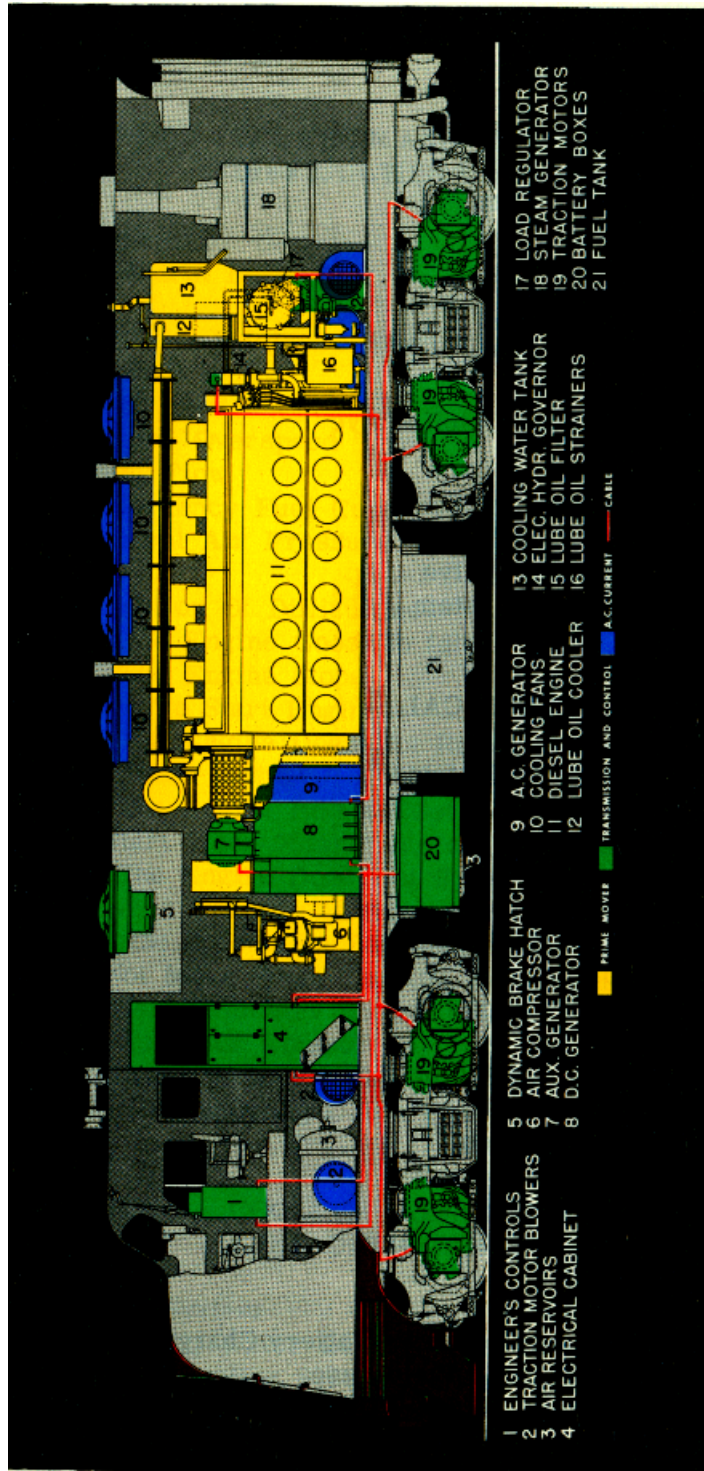

General Arrangement — F9 "A" Unit
Fig. 1-1

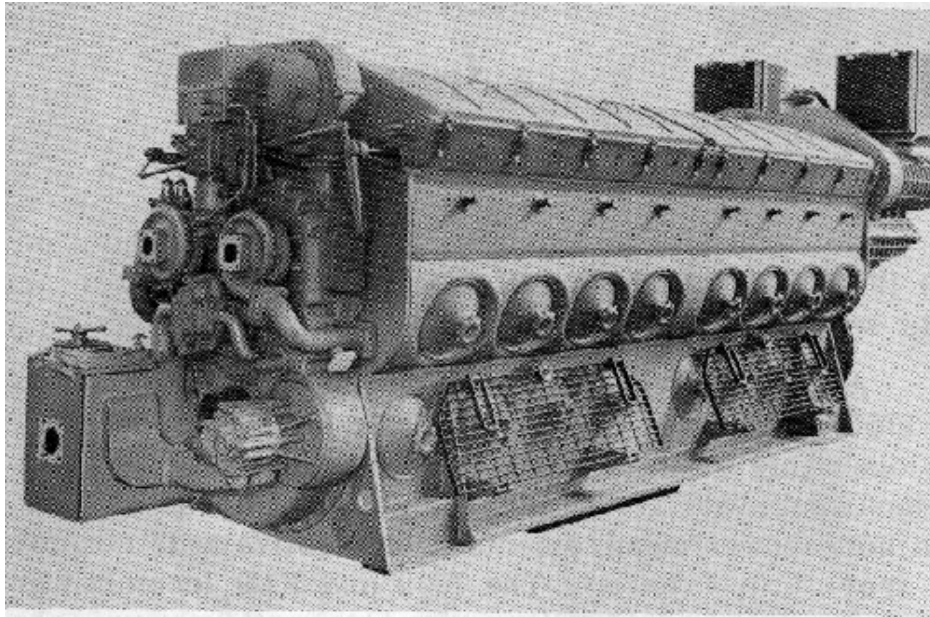

16-Cylinder 567C Diesel Engine
Fig. 1-2

101 Main Generator

The main generator and alternator assembly, Fig. 1-3, is directly connected to the Dieselengine crankshaft through a serrated coupling. The main generator is a constant KW generator which produces direct current at a nominal 600 volts for operation of the traction motors. The armature of the main generator acts as the engine flywheel.

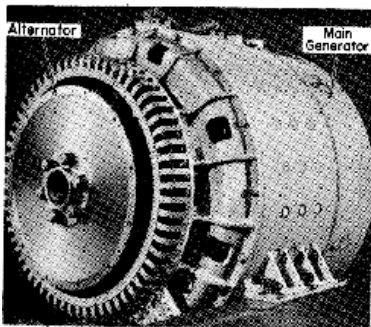

Main Generator and Alternator
Fig. 1-3

102 Alternator The alternator, Fig. 1-3, built into the engine end of the main generator frame, is a three phase alternating current generator. The alternating current (AC) produced is used to drive the four engine water cooling fans and four traction motor blowers.

103 Traction Motors Four Model D37 traction motors, Fig. 1-4, are used in each unit. On the FL9 the center axle of the #2 truck is idle, and necessary for load carrying and braking purposes only. Each motor is geared to the axle, which it drives, by a motor pinion gear meshing with an axle gear. The gear ratio between the two gears, Fig. 1-5, is expressed as a double number such as 62/15. In this case the axle gear has 62 teeth while the pinion has 15 teeth.

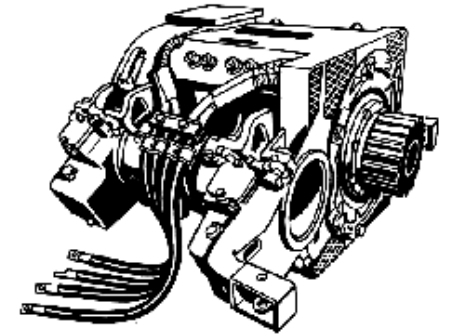

Traction Motor
Fig. 1-4

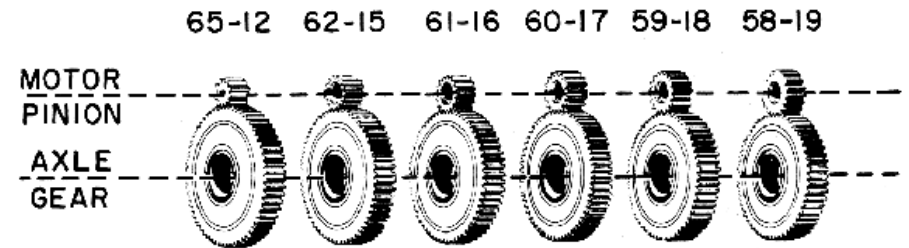

Gear Ratio Chart Fig. 1-5

During acceleration, the traction motor electrical hookup is changed to utilize the full power developed by the main generator, within the range of its current and voltage limits. The changes in the traction motor electrical connections is called transition. Four steps of transition are used as follows:

1. Series-Parallel
2. Series-Parallel Shunt
3. Parallel
4. Parallel-Shunt

The changing of the traction motor electrical connections or transition is completely automatic during locomotive acceleration or deceleration. There is no provision for effecting manual transition or for forestalling the automatic transition.

AUXILIARY EQUIPMENT

104 Storage Battery Power from a 32 cell, 64-volt, storage battery is used to start the Diesel engine. The storage battery boxes are located adjacent to the front end of the fuel tank on each side of the locomotive. With the Diesel engine running, the auxiliary generator charges the storage battery.

105 Auxiliary Generator A 10 KW auxiliary generator, Fig. 1-6, is driven directly from the rear gear train of the engine through flexible couplings. If the locomotive is equipped with a steam generator, an 18 KW auxiliary generator is used. The auxiliary generator produces direct current at 74 volts to charge the battery and supply the low voltage circuits for lighting, main generator battery field excitation and fuel pump operation.

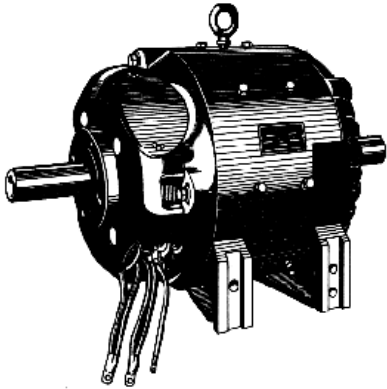

Auxiliary Generator
Fig. 1-6

106 Traction Motor Blowers
Each unit is equipped with four alternating current driven traction motor blower motors, Fig. 1-7. Each motor has a fan, or blower wheel, mounted on its rotor shaft and supplies

- 103 -

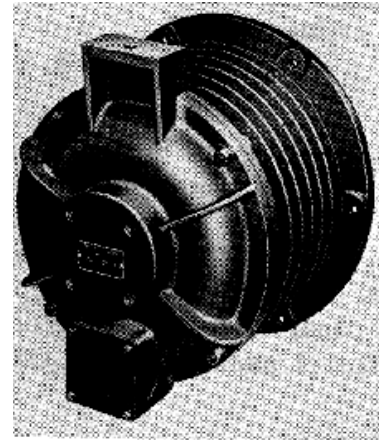

Traction Motor Blower
Fig. 1-7

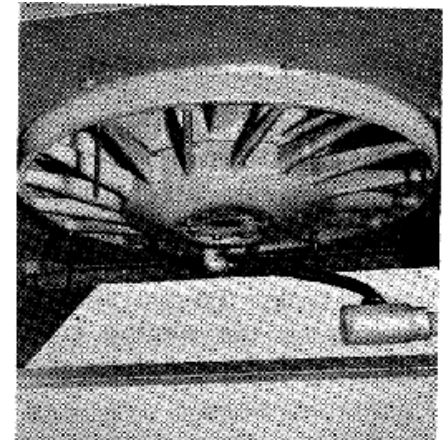

Radiator Cooling Fan
Fig. 1-8

cooling air to one traction motor. The speed of the blower motor varies in proportion to the speed of the Diesel engine.

107 Radiator Cooling Fans Four alternating current driven cooling fan motors, Fig. 1-8, are mounted in the roof of the locomotive above the cooling water radiator sections. A fan mounted on each rotor shaft draws air through the radiator, removing heat from the engine cooling water. The speed of the cooling fan motor varies in proportion to the speed of the Diesel engine.

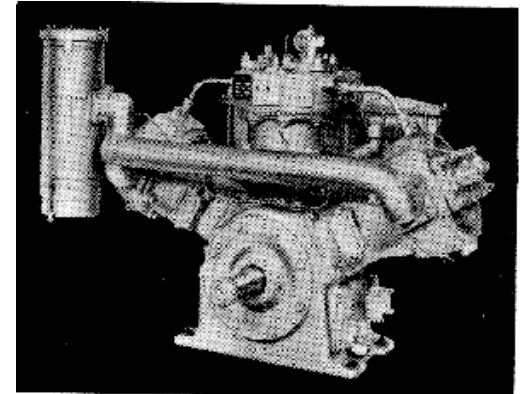

Air Compressor
Fig. 1-9

108 Air Compressor A 3-cylinder, two stage water cooled air compressor, Fig. 1-9, is driven through a flexible coupling from the armature shaft of the main generator. Basically, the F9 type

- 104 -

locomotive is equipped with a Model WBO air compressor which has a rating of 234 CFM displacement at 835 RPM.

109 Fuel Pump The fuel pump is driven by a separate direct current electric motor through a flexible coupling. The pump assembly is mounted on the equipment rack which supports the engine cooling water tank. To operate the fuel pump, the "Fuel Pump" switch on the engine control panel and the "Control" switch on the engineman's control panel must be ON.

OPERATING CONTROLS

Three levers and two brake valve handles control the entire operation of the locomotive. These are the throttle, reverse and selector levers, mounted in the controller, Fig. 1-10, and the independent and automatic brake valve handles.

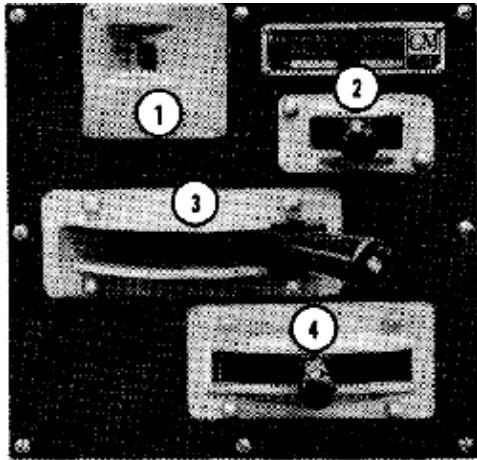

1. Indicator
2. Selector Lever
3. Throttle Lever
4. Reverse Lever

**Controller
Fig. 1-10**

110 Throttle Lever This lever, Fig. 1-11, controls the speed of the engines and the train speed in normal operation. The position of the throttle is indicated by the upper band of the illuminated indicator located in the upper left hand corner of the controller. The throttle has ten positions, Stop, Idle and running speeds 1 to 8. Stop can be obtained by pulling the throttle lever out away from the controller and pushing it one step beyond the idle position; this stops all engines. Idle position is as far forward as the

F9-1-657

DESCRIPTION

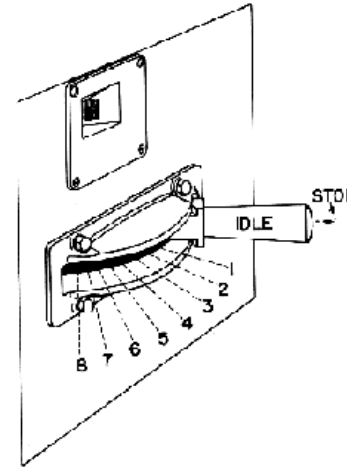

**Throttle Lever Positions
Fig. 1-11**

lever, Fig. 1-12, has three positions: FORWARD, NEUTRAL AND REVERSE. Direction in which the locomotive moves is controlled by movement of this lever to the forward or reverse position. With the reverse lever in neutral, no power will be developed if the throttle is opened, even though the engine speed will increase. The reverse lever should be moved ONLY when the locomotive is standing still.

The reverse lever can be removed from the control stand only when the lever is in the "Neutral" position, the throttle is in

throttle lever can be moved without pulling it out away from the controller. Each running notch on the throttle increases the engine speed 80 RPM from 275 RPM at idle to 835 RPM at full throttle. The throttle may be opened as rapidly as desired PROVIDING OPERATING CONDITIONS AND TRAIN CONSIST PERMITS. Normally, the throttle should be opened one notch at a time. The throttle may be closed completely with one motion in an emergency, but should be closed only one notch at a time in normal operation.

111 Reverse Lever The reverse

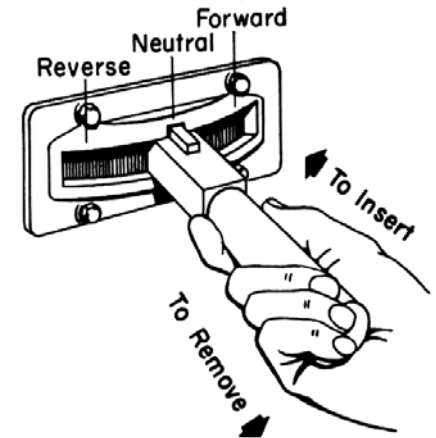

**Reverse Lever Positions
Fig. 1-12**

"Idle" and the selector lever is in "Off." Removal of the reverse lever locks the operating controls in the controller. Remove the reverse lever from all nonoperating control stands.

112 Selector Lever F9, FP9 and FL9 locomotives are basically equipped with automatic transition. On such locomotives transition is FULLY AUTOMATIC, both forward and backward, and no provision is made basically for making transition manually on such units. However, a selector lever is supplied with "A" units solely for the purpose of controlling dynamic braking and/or effecting manual transition on units not equipped with automatic transition coupled to F9 type locomotives.

The position of the lever is indicated by the lower indicating band illuminated through the opening at the upper left corner of the controller front panel. Movement of this lever all the way in one direction will index the selector cam one notch in that direction. The lever is spring loaded and must be allowed to return to center position before indexing again in either direction.

When the selector is put in the braking "B" position, a mechanical arrangement lifts the throttle cam drum vertically to disengage the power switches and engage the braking switches. In this position the throttle handle moves freely (without notching) to control a 500 ohm braking rheostat. (See Art. 229 for dynamic brake operation.)

113 Mechanical Interlocks On The Controller The levers on the control stand are interlocked so that:

1. Reverse lever in NEUTRAL.
 - a. Throttle may be moved to any position.
 - b. Selector may be moved between OFF and 1 (or the 1-4 range if used).

2. Reverse lever in FORWARD or REVERSE.
 - a. Throttle may be moved to any position.
 - b. Selector may be moved to any position.
3. Throttle in IDLE or STOP.
 - a. Reverse lever may be moved to any position.
 - b. Selector may be moved to any position.
4. Throttle above IDLE.
 - a. Reverse lever position cannot be changed.
 - b. Selector is locked in either B or 1 (or the 1-4 range if used).
5. Selector in OFF.
 - a. Reverse lever may be moved to any position.
 - b. Throttle may be moved to IDLE and STOP.
6. Selector in 1 (also 2, 3 and 4 when used).
 - a. Reverse lever may be moved to any position.
 - b. Throttle may be moved to any position.
7. Selector in "B."
 - a. Reverse lever cannot be moved.
 - b. Throttle may be moved to any position.

Where positions 2, 3 and 4 for manual transition are incorporated in the selector, this lever may be moved from 1 to these positions if the reverse lever is in FORWARD or REVERSE, and with the throttle in any position. Permissible movement of the throttle and reverse levers with the selector in 2, 3, or 4 is the same as with the selector in 1.

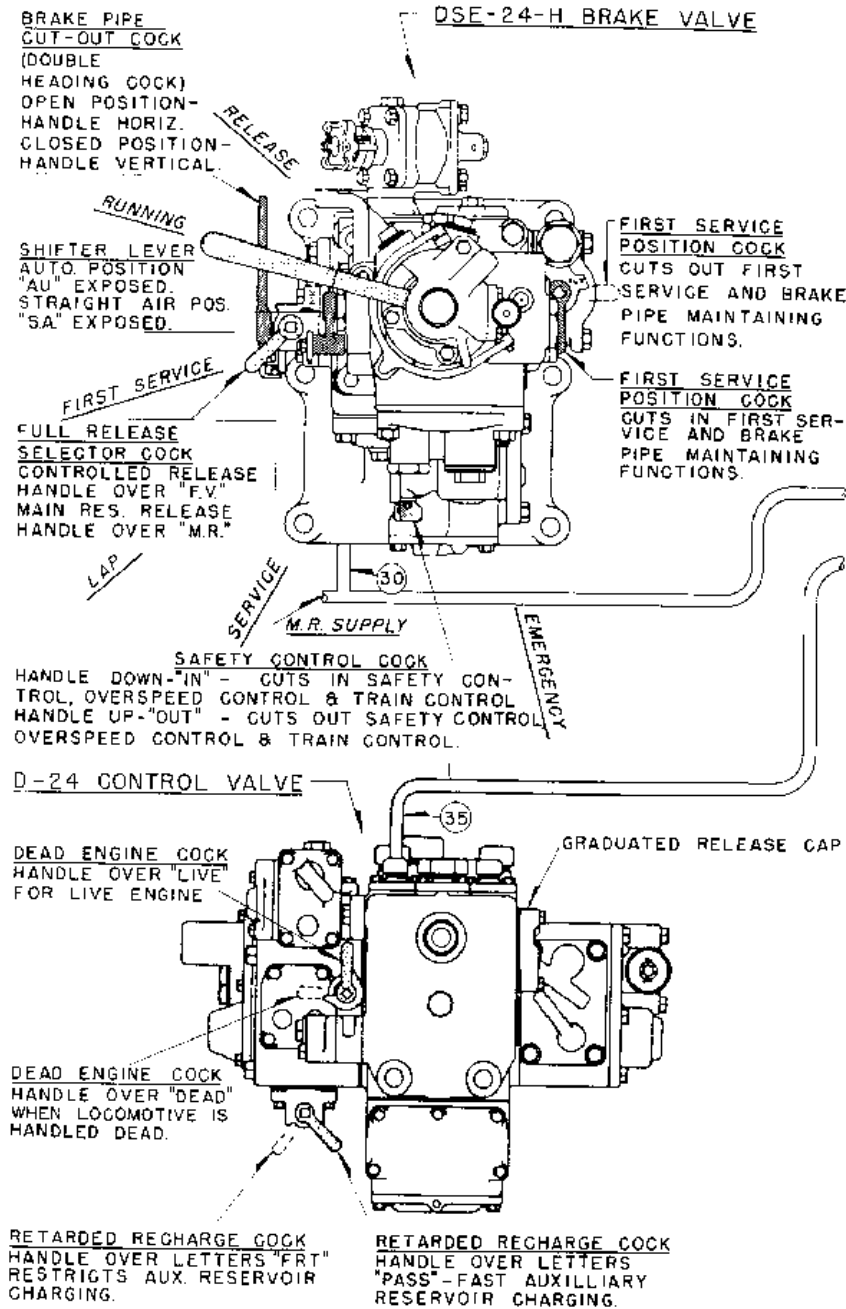

K-2-A ROTAIR VALVE

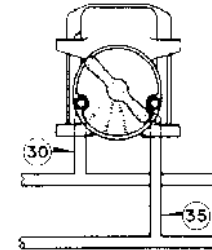

HANDLE OVER LETTERS "FRGT" *
CUTS IN CONTROLLED EMERGENCY FEATURE, SPLIT SERVICE REDUCTION, & INDEPENDENT BRAKE VALVE.

HANDLE OVER LETTERS "FRGT LAP" *
CUTS OUT INDEPENDENT BRAKE VALVE. CONTROLLED EMERGENCY STILL IN EFFECT.

HANDLE OVER LETTERS "PASS LAP" *
CUTS OUT CONTROLLED EMERGENCY & THE INDEPENDENT BRAKE VALVE.

HANDLE OVER LETTERS "PASS"
ALL FEATURES REMAIN CUTOUT AS IN "PASS LAP," EXCEPT INDEPENDENT BRAKE VALVE IS CUT IN.

* POSITION USED FOR TRAILING "A" UNITS.

"B" UNIT CONTROL VALVE SECTION.

NOTE: WHEN DOUBLE HEADING, THE ROTAIR VALVE ON THE SECOND OPERATING UNIT SHOULD BE LEFT IN A LIVE POSITION, "FRGT" OR "PASS", TO RETAIN USE OF INDEPENDENT BRAKE VALVE.

WHEN OPERATING A "B" UNIT ALONE WITH THE HOSTLER'S CONTROL, THE CONTROLLED EMERGENCY SELECTOR COCK MUST BE PLACED IN "PASS" POSITION TO EFFECT QUICK ACTING EMERGENCY IF NEEDED

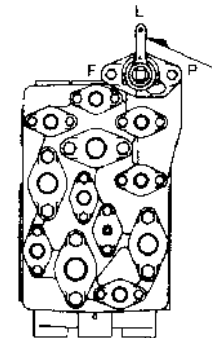

HANDLE OVER "F"
CUTS IN CONTROLLED-EMERGENCY BRAKE CYLINDER PRESSURE DEVELOPMENT FEATURE.

HANDLE OVER "L"
POSITION NOT USED WITH OUR EQUIPMENT. HANDLE MUST BE IN PASSENGER OR FREIGHT POSITION.

HANDLE OVER "P"
CUTS OUT CONTROLLED-EMERGENCY BRAKE CYLINDER PRESSURE DEVELOPMENT FEATURE.

VIEW OF PIPE BRACKET FOR CONTROL VALVES SHOWING CONTROLLED-EMERGENCY CUT-OUT COCK IN "B" UNITS

24RL Brake Valve Handle Positions
All Types Of Service
Fig. 1-15

Before moving the locomotive, be sure the brakes are completely released in all units. Whenever anyone is working around the locomotive trucks, the hand brakes should be applied.

138 Manual Sanding Valve When the locomotive is equipped with the hinged automatic brake valve handle, sanding is accomplished by depressing the lever beyond the safety control position previously described. This movement operates the sanding bail which opens a port to supply air to the sanding equipment. On locomotives having a rigid handle on the automatic brake valve, an independent sanding valve is provided.

139 Classification Lights A permanently fixed, clear bull's-eye is provided on each side of the locomotive nose section. Inside the nose section and behind each bull's-eye, a small compartment contains the classification light bulb and colored lenses. Red and green lenses are provided in each compartment which can be moved into position between the bulb and bull's-eye. To accomplish this, a locking pin is removed, the desired lens swung into place and the locking pin replaced. The lens box is accessible from inside the locomotive nose section. When both lenses are out of position the permanent bull's-eye lens will show a white light, thus making three colors available.

140 Number Box Lights Translucent number slides or burnt bulbs are changed from inside the nose compartment. The switch for these lights is located on the engineman's control panel.

141 Horn Valves The horns (front and rear) are operated by air valves which are controlled by pull-cords, above the control stand. The horn shutoff valve, accessible from inside the nose compartment is located in front of the No. 2 main reservoir.

142 Bell Ringer The signal bell is under the locomotive floor behind the pilot on the left side. It is operated by an air valve located at the engineman's station. The bell shutoff valve, accessible from inside the nose compartment, is located to the left side of the front end of the No. 2 main reservoir.

143 Windshield Wipers The windshield wipers are controlled by valves, one of which is located on the engineman's instrument panel, and one on the panel on the fireman's side of the cab. These wipers operate independently of each other. The wipers should not be run on a dry window as they may scratch the glass.

144 Cab Heaters And Defrosters A cab heater is located on each side of the cab. Hot water from the engine cooling system passes through the heaters, and motor driven fans provide air circulation. The water flow to both heaters is controlled by a valve in the supply line, located above the left hand engineroom steps. This valve must be kept wide open at all times in freezing weather. The heater output can be varied by use of the cab heater switches. The switches have four positions "OFF" 1, 2, 3, providing three different motor speeds. If the lead unit engine is shut down in freezing weather, steam, if available, may be admitted to the cab heaters.

Each side of the cab is equipped with a defroster motor and fan which blows heated air on the inside of the front cab windows. Both motors are controlled by the one defroster switch mounted on the engineman's control stand under the controller.

145 Trucks The F9 and FP9 locomotive is equipped with two four wheel truck assemblies and are interchangeable and reversible. Improved riding qualities and greater stability are obtained by a new arrangement of load suspension.

The FL9 locomotive, due to its longer length, is equipped with two different type trucks. At the front of the locomotive a fully flexible two motor four wheel truck assembly is provided. While at the rear of the locomotive a fully flexible two motor six wheel truck is employed, with the center axle being an idler. The axles on all F9 type locomotives are equipped with Hyatt roller bearing journal boxes, Fig. 1-33. A stench bomb on each journal box will release a pungent odor if the temperature inside the journal box exceeds 200° F.

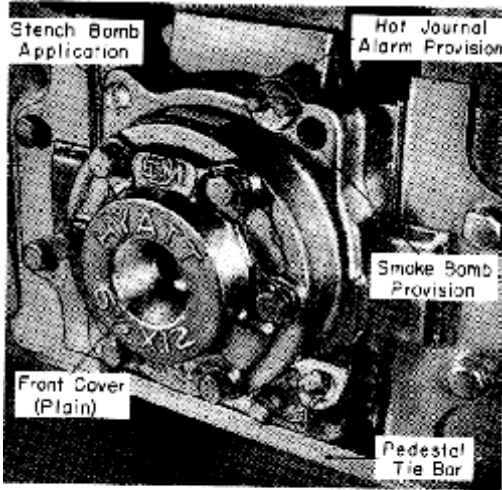

**Hyatt Journal Box
Fig. 1-33**

- 129 -

SECTION 2

OPERATION

The successful and dependable operation of the locomotive is dependent upon the quality of inspection and repair at regular maintenance periods, as well as the proficiency of the operating crews. As a supplement to terminal maintenance, a "pre-service check" should be made by the engine crew upon boarding the locomotive.

BASIC INFORMATION

200 When Boarding The Locomotive

A. Ground Inspection - Locomotive Exterior and Running Gear

Check for:

1. Fuel oil, lube oil, water or air leaking from the locomotive.
2. Loose or dragging parts.
3. Proper positioning of angle cocks and shutoff valves.
4. Observe brake cylinder piston travel, if air brakes are set.
5. C Condition of brake shoes.
6. Adequate fuel supply showing in fuel tank full length sight glass.
7. Drain condensate from main reservoirs.
8. Proper connection of air hoses and jumper cables (if used in multiple unit operation).

B. Engineroom Inspection

In the engineroom with engines running, the following checks should be made (if engines are stopped, see Arts. 201 and 202 for starting instructions):

- 200 -

1. Lubricating oil supply.
 - a. Diesel engine oil pan dipstick.
 - b. Governor sight glass.
 - c. Air compressor sight glass.
2. Engine cooling water level in supply tank.
3. Air compressor lube oil pressure gauge.
4. Diesel engine lube oil pressure gauge.
5. Fuel flow in "fuel return" sight glass.
6. Check for oil, water and fuel leaks.
7. Drain condensation from air brake system.
8. Check position of controlled emergency cock on the D24 control valves in all "B" units. The position of the cock should correspond with the setting of the rotair valve in the operating cab either "FRGT" or "PASS."
9. Release hand brake in each unit.
10. Check all battery ammeters to see that the auxiliary generator in each unit is "charging." The ammeters should read "0" or a slight charge.
11. Place isolation switch in the RUN position.
12. In the electrical cabinets, all fuses must be securely in place and all knife switches should be closed.
13. Close air box drain valves.

C. Operating Cab Inspection

1. Check to see that the "Control" and "Engine Run" switches are in the "ON" position.

NOTE: With older type units trailing in the locomotive consist, the "Engine Run" switch in the lead F9 type locomotive must be IN to keep the fuel pumps of those units running.

2. Place the throttle in IDLE, the reverse lever in neutral and the selector lever in No. 1 position. 3. Check position of the automatic and independent brake valves. Apply locomotive brakes.

4. Place brake pipe cutout cock in " cut-in" or " open" position (handle horizontal).
5. Position rotair valve for service required. If the locomotive is to run light or haul a short freight train, the rotair valves in the operating and nonoperating cabs should be placed in the PASS and PASS LAP positions, respectively; the controlled emergency cutout cock on the "B" unit control valves should also be placed in the PASS position. This insures a QUICK ACTING EMERGENCY on the locomotive.

With long freight trains the above valves should be placed in FRGT LAP on the trailing "A" unit, and in FRGT on "B" units and the operating "A" unit. This will effect a CONTROLLED EMERGENCY action on each unit.

The CONTROLLED EMERGENCY action CAN BE NULLIFIED (on the operating "A" unit only) if a quick acting emergency is desired, by simultaneously placing the independent and automatic brake valves in the full application and emergency positions, respectively.

6. If the locomotive has dynamic brakes, set the unit selector switch to correspond with the number of units in the consist (1, 2, 3 or 4).
7. Check battery ammeter.

D. Trailing Cab Inspection

1. All switches on the engineman's control station should be in "OFF" position.
2. Throttle lever should be in Idle, selector lever in OFF position and reverse lever removed from control stand.
3. Remove independent brake valve and removable automatic brake valve handles.
4. Position rotair valve in proper LAP position (PASS LAP or FRGT LAP corresponding to service of rotair valve in lead unit).

5. Place brake pipe cutout cock in "cut - out,, or "closed" position (handle vertical).
6. Check battery ammeter.

201 Precautions Before Starting Engine The following operations should be performed when an engine is to be started after a layover. If the engine has been stopped for a considerable period of time, the cylinders should be tested for fuel or water accumulation, as outlined in Item 10, before starting the engine.

1. With the locomotive stopped, place the independent brake valve in FULL application position.
2. Check position of all valves: Drains in cooling system, lube oil system and air reservoirs.
3. Check engine cooling water level. 4. Check lube oil supply.
 - a. In Diesel engine oil pan. b. In engine governor.
 - c. In air compressor.
5. Place the isolation switch in the START position. 6. In the electrical cabinet, on the distribution and low voltage panels, see that all the fuses are securely in place and that all knife switches are closed.
7. Remove the reverse lever from the controller. 8. At engineman's control station place the "Control" and "Engine Run" switches in the ON position.

NOTE: When operating as a lead unit in multiple with older type units not equipped with an "Engine Run" switch, the "Engine Run" switch on the lead F9 type locomotive must be ON to start and keep the fuel pumps of the trailing older type units running.

9. Check the PCS light; it should be OUT.
10. Test for water accumulation in engine cylinders.
 - a. Remove 400 ampere starting fuse.
 - b. Open all cylinder test valves (3 full turns), Fig. 2-1.

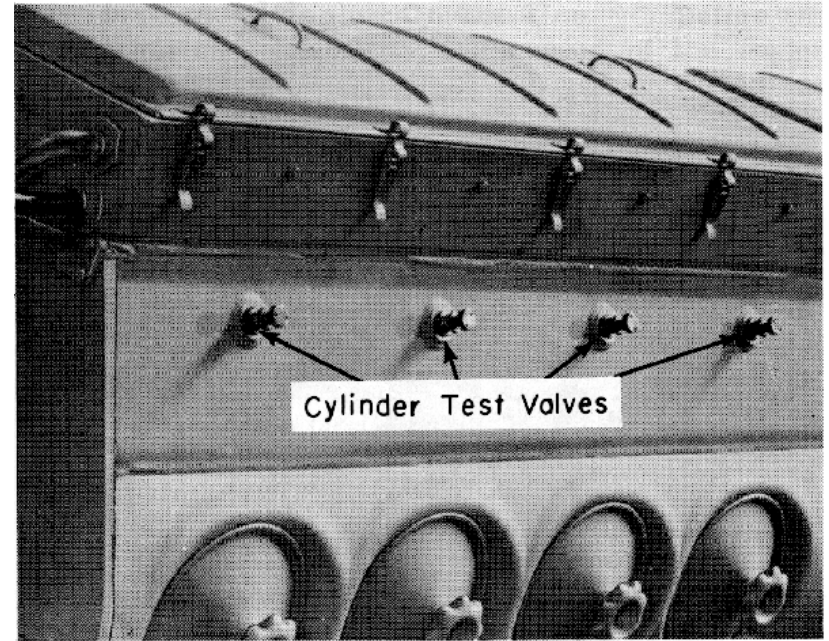

Cylinder Test Valves Fig. 2-1

- c. Rotate engine at least one complete revolution by use of the engine turning jack.
- d. Watch the cylinder test valves while engine is being rotated. If water is discharged from any test valve, do not attempt to start the engine until the cause of the water accumulation has been corrected.
- e. Close cylinder test valves.
- f. Replace 400 ampere starting fuse.

202 To Start Engine After completing the items mentioned in Art. 201, the engine is started by performing the following items:

1. Check for fuel flow through "return fuel sight glass" on fuel filter mounted on the front of

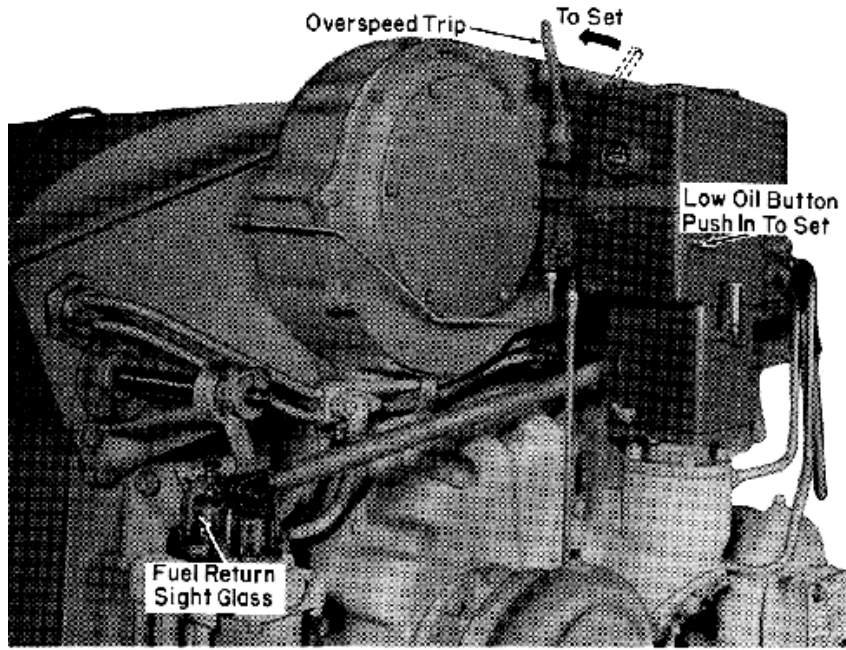

Overspeed Trip And Fuel Flow Check
Fig. 2-2

the engine, Fig. 2-2.

2. Check position of overspeed trip.
3. Check position of governor low oil trip button.
4. With the isolation switch in the START position, firmly press IN the engine START button and hold it in until engine completely starts (not over 15 seconds), Fig. 2-3.



Starting Engine
Fig. 2-3

5. After the engine is started, check lube oil pressure.
6. Check ground relay.
7. Idle the engine until water temperature becomes normal.
8. See Section 3 if trouble is experienced in starting the engine.

203 Placing An Engine On The Line Before the engineman can control the speed of the engine with the throttle lever, the engine must be placed "on the line," and the "Engine Run" switch must be in the "ON" position.

1. After the oil pressure has built up, the engine is placed "on the line" by merely placing the isolation switch in the RUN position, Fig. 2-4.
2. If an engine has been taken off the line for any reason, DO NOT place it "on the line" if the locomotive is being operated in dynamic braking.



Placing Engine On-the-Line
Fig. 2-4

204 To Stop Engine There are three ways of stopping the engine, which can be designated as (1) normal, (2) under power and (3) emergency.



Stopping Engine
Fig. 2-5

1. Normally stopping an engine applies when the locomotive is standing still. In this case the isolation switch is placed in the START position and the STOP button on the engine control panel is pressed IN until the engine stops, Fig. 2-5.
2. Under power, in dynamic braking, or whenever necessary, an engine can be taken "off the line" by pulling the engine manual layshaft closed until the engine stops, Fig. 2-6. After stopping the engine,

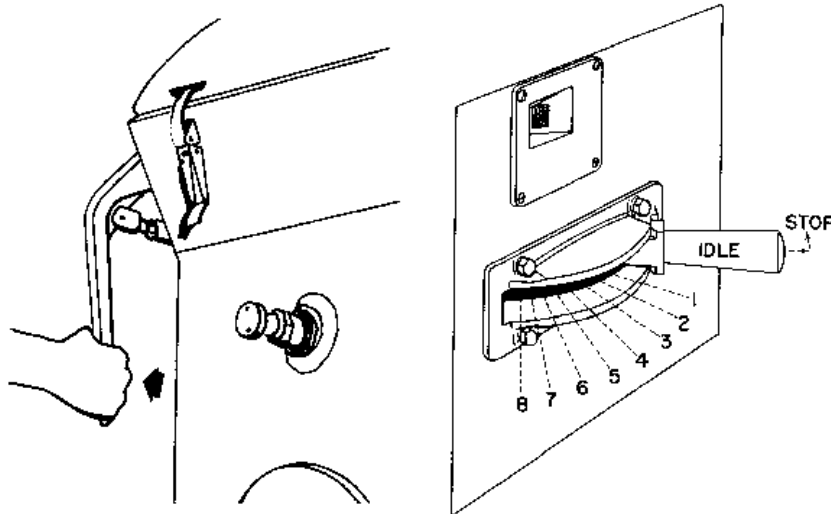

To Stop Engine
Fig. 2-6

Emergency Stop
Fig. 2-7

place the isolation switch in the START position.

3. In an emergency all engines "on the line" are simultaneously stopped by pulling the throttle lever away from the controller, Fig. 2-7, and pushing the throttle lever as far to the right as possible to the STOP position.

When engines are shut down in this manner, the "Blue" alternator failure light will light up and alarm bells will ring. The isolation switch must be placed in the "Start" position on each unit to silence the bells and extinguish the lights.

205 Securing Locomotive For Layover

1. Place independent brake valve handle in FULL application position.
2. Place the reverse lever in NEUTRAL and the throttle in IDLE.
3. Place the selector lever in the OFF position and remove the reverse lever from the control stand.

4. In each unit, at the engine control panel, place the isolation switch in the START position and press in on STOP button until engine stops. When engine stops, place "Fuel Pump" switch in "OFF" position.
5. Place all switches at the engineman's control panel in the OFF position.
6. In the electrical cabinet, on the distribution and low voltage panels, open all knife switches.
7. Set hand brakes and block wheels if necessary.
8. Cover exhaust stacks, if there is danger of a severe rain.
9. Take proper precautions against the freezing of the cooling system water in cold weather, see Art. 221.

HANDLING LOCOMOTIVE

206 precautions Before Moving Locomotive

1. NEVER move a locomotive, under its own power, without having first observed proper application and release of the brake shoes.
2. Check the main reservoir and the control air pressures.
3. Release hand brakes and remove any blocking of the wheels.
4. Engine water temperature should be normal.
5. See that ground relays are set and isolation switches in "RUN" position.

207 Handling Light Locomotive With the engines placed "on the line" and cab preparations completed the locomotive is handled as follows:

1. Move "Generator Field" switch to ON.
2. Insert and move the reverse lever to the desired direction. (This lever is to be moved ONLY when the locomotive is standing still.)

3. Place the selector lever in the No. 1 position. 4. Depress safety control foot pedal (if used).
5. Release the air brakes.
6. Open throttle a notch at a time.
7. Note that the locomotive rolls freely - care should be used in judging the speed.
8. The throttle must be in IDLE before coming to a dead stop.

208 Coupling To Train And Pumping Up Air

1. Locomotive should not be moved with air hoses hanging free on nose of "A" units.
2. In backing onto a train it may be desirable to use the attendant's call in rear "A" unit or train signal whistle valves at rear of "A" and "B" units for signaling.
3. Valve and cocks.
 - a. Nose angle cock is behind pilot on fireman's side.
 - b. Steam line valve is behind pilot on engineman's side (pilot plate must be removed to connect steam line).
 - c. The trainline signal whistle cutoff cock in the nose compartment is on the signal line reducing valve at the front of air brake rack.
4. After coupling to a train, stretch coupling to make sure it is properly made. If main reservoir pressure falls below feed valve setting when brakes are cut in, proceed as follows:
 - a. Place "Generator Field" switch in "OFF" position.
 - b. Place reverse lever in neutral.
 - c. Open throttle to 4th, 5th or 6th notch as needed.

209 Starting A Train Starting a train depends not only on the kind of locomotive being used, but also on the type, length, weight, grade, weather conditions and the amount of slack in the train. Because of the locomotive's very HIGH STARTING TRACTIVE EFFORT it is

important that the air brakes be COMPLETELY released before attempting to start the train. Actual tests have shown that a 100 car train, having the average uniformly distributed leakage, may require 9 minutes to completely release the brakes. It requires approximately 30 minutes (with 130 pound main reservoir pressure) to completely charge a depleted air system on a similar 100 car train.

The load indicating meter, Fig. 2-8, can be used as a PULL METER to judge the tractive effort of the locomotive. Merely looking at the ground and listening to the engine exhaust may give a false indication of the locomotive's draw bar pull.

These units are designed to have a COMPARATIVELY RAPID YET SMOOTH BUILD UP OF POWER. Load regulator movement will begin as soon as the throttle is opened. The rate of movement and power build up is determined by a special design pilot valve bushing in the governor.

With this arrangement a power build-up equal to the throttle position is very quickly obtained. Any further advancement of the



Load Indicating Meter
Fig. 2-8

throttle is accompanied are released. by an almost immediate additional increase in power. This may be seen by observing the speed with which the load indicating meter responds to throttle advance.

With a power control of this type the rate and extent of power build-up is left largely to the desire of the engineman yet is still controlled by the load regulator and engine governor.

When ready to start, the following general procedure is recommended:

1. Place the selector lever in the No. 1 position and move the reverse lever to the desired direction.
2. Place foot on the safety control foot pedal (DEADMAN) and release the brakes.
3. Open the throttle one notch every 1 to 2 seconds as follows:
 - a. To Run 1 - note the load meter pointer start moving to the right.
 - b. To Run 2 - note engine speed increase. At an easy starting place, the locomotive may start the train in Run 1 or 2.
 - c. To Run 3 or higher (experience and the demands of the schedule will determine this) until the locomotive moves.
4. Reduce throttle one or more notches if acceleration is too rapid.
5. After the train is stretched, advance throttle as desired.

NOTE: If the wheel slip indicator flashes continuously, reduce the throttle one notch. Apply sand as needed to prevent further slipping and reopen the throttle when rail conditions improve. See Art. 210 - Automatic Sanding In Power.

Although it will generally be unnecessary to take slack in starting, there will be cases where it is wise to do so after making sure that all brakes

are released. The throttle should be opened one notch at a time, in starting the train. A TONNAGE TRAIN SHOULD BE STARTED IN AS LOW A THROTTLE POSITION AS POSSIBLE, BEARING IN MIND THAT THE SPEED OF LOCOMOTIVE MUST BE KEPT AT A MINIMUM UNTIL THE TRAIN HAS BEEN STRETCHED. Sometimes it is advisable to reduce the throttle a notch or two the moment the locomotive begins to move, in order to prevent stretching the slack too quickly. The engineman must be the judge of the acceleration and the conditions under which the train is being started.

When the locomotive has moved far enough to completely stretch the train, the throttle may be advanced as quickly as desired, but should not be advanced so quickly that slipping results. Smooth acceleration is obtained by opening the throttle one notch each time the pointer of the load meter begins moving to the left.

210 Automatic Sanding In Power These locomotives are equipped with automatic sanding in power to assist in controlling wheel slip. When operating in transition 1 (as in starting a train) sanding automatically takes place while slip is in its "creep" or initial stage. In this manner a wheel slip is "anticipated" and prevented before any appreciable loss of tractive effort occurs.

In transition 2, 3, and 4 (and on some occasions in transition 1) automatic sanding, caused by wheel slip, is accompanied by a reduction in main generator output.

Duration of sanding, after the wheel slip or creep has stopped, is controlled by the setting of a time delay sanding (TDS) relay. An "Automatic Sanding" switch on the engineman's control panel cuts in or out this sanding-in-power feature.

With the automatic sanding feature "cut in" (automatic-sanding switch in ON position) throttle reduction tp avoid repeated wheel slip

to avoid repeated wheel slip will rarely be necessary. Also, manual operation of the sanders by the engineman at points on the road where slippage is likely to occur can be eliminated.

211 Acceleration Of A Train After the throttle is in the 8th notch and the train begins to accelerate, the indicating meter pointer will move slowly to the left. Forward and backward transition will automatically take place without any attention on the part of the engineman, other than necessary throttle reductions to keep under any speed restriction.

212 Slowing Down Because Of A Grade As the train slows down on a grade the pointer on the indicating meter will move slowly toward the right. Backward transition will take place automatically.

213 Locomotive Operation At Very Slow Speeds The operation of these locomotives, regardless of gear ratio, is not governed by any specific short time ratings.

In most cases, the locomotives may be operated up to the limit of the adhesion attainable.

Pulling tonnage trains at very slow speeds should be done with the throttle in Run 8 position. In the event of a wheel slip indication (wheel slip light flashes on), the locomotive wheel slip control system will automatically apply sand to the rails (automatic sanding switch in ON position) and reduce the power to a point where slipping stops. If continuous wheel slipping on sand occurs, due to unusual rail operating conditions, the throttle can be reduced for short periods. Under these circumstances, operate at reduced throttle, provided it is not necessary to reduce below the 5th throttle position to correct for a continuous wheel slip. If slipping persists, tonnage should be reduced.

If there are any questions about an unusual operation of the locomotive, such as a passenger locomotive operating in freight service, Electro-Motive will, upon request, analyze the actual operation and make specific recommendations.

BRAKING

214 Air Braking With Power The method of handling the air brake equipment is left to the discretion of the individual railroad.

However, when braking with power it must be remembered that for any given throttle position the draw bar pull rapidly increases as the train speed decreases. This pull might become great enough to part the train unless the throttle is reduced as the train speed drops. Since the pull of the locomotive is indicated by the amperage on the load meter, the engineman can maintain a constant pull on the train during a slow down, by keeping a steady amperage on the load meter. This is accomplished by reducing the throttle a notch whenever the amperage starts to increase. It is recommended that the independent brakes be kept fully released during power braking. The throttle **MUST** be in Idle before the locomotive comes to a stop.

MISCELLANEOUS OPERATING INSTRUCTIONS

215 Multiple Unit Operation In operating these units in multiple with each other the operating controls of the locomotive are set up as outlined in Art. 217. When set up for multiple unit operation, the following precautions should be observed.

If the units of the consist are of different gear ratios, the locomotive should not be operated at speeds in excess of that recommended for the unit having the lowest maximum permissible speed.

If some of the units in the consist have an overload short time rating, the locomotive operation should be governed by the overload short time rating of the unit having the highest minimum speed.

When "F" type units not equipped with automatic transition are operated in multiple with an F9 type locomotive as the lead unit, the selector lever must be moved to effect forward and backward transition on these units. Movement of the selector lever to effect manual transition is made with reference to the locomotive speed, depending on the gear ratio of the unit or units being operated manually, see table below. The throttle should be reduced to the 6th notch when moving the selector lever from 2 to 3 or 3 to 2. Movement of the selector lever in the F9 type lead unit does not effect transition on that unit or any other units in the consist equipped with automatic transition.

MANUAL TRANSITION SPEEDS FOR VARIOUS GEAR RATIOS

From Pos.	To Pos.	65/12	62/15	61/16	60/17	59/18	58/19	57/20	56/21
1	2	15	19	21	23	24	26	28	30
2	3	19	25	27	29	31	34	36	39
3	4	40	52	57	61	66	71	75	81
4	3	40	52	57	61	66	71	75	81
3	2	19	25	27	29	31	34	36	39
2	1	15	19	21	23	24	26	28	30

When the "F" type unit not equipped with automatic transition is operated as the lead unit in the consist, manual transition should be effected by moving the selector handle in accordance with the load meter indications. Automatic transition, in trailing units so equipped, will take place automatically without reference to the movement of the selector handle.

216 Uncoupling And Coupling Units In Locomotive

1. To uncouple units:
 - a. Apply brakes and close angle cocks on both units on all air hoses.
 - b. Take down all jumper cables between units.
 - c. Break hoses and separate units by uncoupling.
2. In coupling units:
 - a. Couple and stretch units to insure couplers are locked.
 - b. Connect hoses and jumpers and be sure all angle cocks on all air hoses are opened in both units.
 - c. In any non-operating cab, cut out the brakes and place all switches at the engineman's control panel in "OFF" position. Remove the reverse lever from the controller in all trailing units.

217 Changing Operating Ends When the consist of the locomotive includes two "A" units, the following procedure should be followed in changing from one operating end to the opposite end:

1. If the locomotive is equipped with electropneumatic brakes and the brake has been in use, change the brake selector on the automatic brake valve to "AUTO" and open electropneumatic brake switch.
2. REMOVE REVERSE LEVER.
3. With safety control foot pedal depressed, make an automatic 20 pound brake pipe reduction.
4. Move the independent brake valve handle to release position; observe that the locomotive brakes are still applied.
5. Release safety control foot pedal.
6. Close brake pipe cutout cock (handle vertical).
7. Move r of a rotair r valve to "Passenger Lap" or "Freight Lap" depending on service required.

8. Move the automatic brake valve handle to the RUNNING position and remove the handle from the brake valve.
9. Remove the independent brake valve handle in the RELEASE position.
10. Place all switches at the engineman's control panel in "OFF" position.
11. Place "Headlight Control" switch in "Controlled" position.
12. Proceed to cab at opposite end. Check PC switch and reset if necessary.
13. On engineman's control panel move "Control" and "Engine Run" switches to "ON" position, and any other switches on the panel that are necessary.
14. Insert reverse lever, automatic brake valve and independent brake valve handles.
15. Move the rotair valve to the "FRGT" or "PASS" position, depending upon the service desired.
16. Place the independent brake valve handle in the FULL application position.
17. Open brake pipe cutout cock (handle horizontal), slowly, pausing from five to ten seconds in mid position.
18. Place unit selector switch in proper position if locomotive is equipped with dynamic braking.
19. Place "Headlight Control" switch in proper "Controlling" position.
20. When ready to move locomotive, depress safety control foot pedal or automatic brake valve handle and move the independent brake valve to RELEASE position.

NOTE: The "controlled emergency cock" on the control valve section in all "B" units should be placed in "Freight" (F) or "Passenger" (P) position to correspond to the rotair valve position in the lead "A" unit.

218 Handling Locomotive Dead-in-Train

1. Air brake equipment.
 - a. Place the independent and automatic brake valve handles in the Release and Running positions respectively.
 - b. Close the brake pipe cutout cock (handle vertical).
 - c. Open the dead engine cutout cock.
 - d. Move the rotair valve to the passenger (PASS) position.

The locomotive brake will now operate like that of a car in the train.

2. Electrical control equipment.
 - a. Remove the reverse lever from the controller.
 - b. Place the isolation switch in the START position. If it is necessary to keep the engine idling for any reason while towing locomotive, the "Control" and "Engine Run" switches must be left ON.
 - c. If locomotive is to be hauled in a train any appreciable distance, reverser switch, Fig. 2-9, should be placed in Neutral and locked in that position. Center the reverser drum switch in neutral by manually operating the forward and reverse magnet valve buttons.

To lock the reverser switch in neutral, remove the locking pin which during normal operation is screwed into the left hand side of the reverser housing. With the reverser drum switch in neutral, insert pin into hole in the right side of reverser housing. Push pin in all the way through the reverser switch shaft and screw pin into threaded hole.

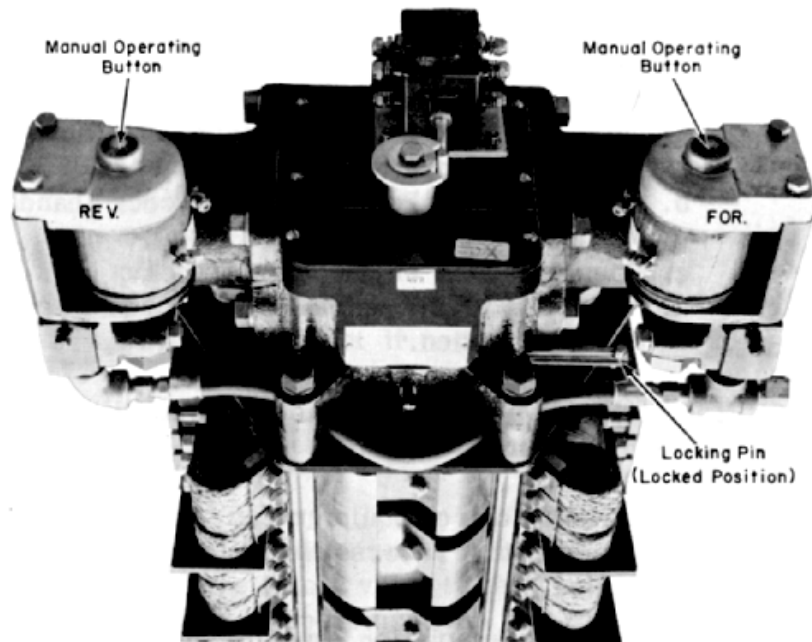

Reverser Switch - Locked In Neutral
Fig. 2-9

219 Doubleheading Prior to doubleheading behind another locomotive, make a full service brake pipe reduction with the automatic brake valve and close the doubleheading cock. Leave the rotair valve in "PASS" or "FRGT" position, depending on the type of service required. Return the automatic brake valve handle to the running position and place the independent brake valve in release position. The operation of the throttle is normal, but the brakes are controlled from the lead locomotive. The engineman on the second locomotive may make an emergency application of the brakes with the automatic brake valve, and/or may release his locomotive brakes by depressing the independent brake valve handle, in the release position.

220 Operation In Helper Service Basically, there is no difference in the instructions for operating the F9 type locomotive as a helper or with a helper.

In most cases, operation in either service up to the limit of the adhesion attainable can be obtained. The throttle can be reduced, for short periods, to prevent excessive wheel slip, but the locomotive should not be operated below the 5th throttle position.

If other Diesel locomotives having overload short time ratings are used with the F9 type locomotive in helper service, their operation will be governed by the permissible length of time the locomotives can operate at the short time ratings.

To obtain a maximum tonnage rating for any single application, Electro-Motive will, upon request, analyze the actual operation and make specific tonnage rating recommendations.

221 Freezing Weather Precautions In freezing weather, precautions must be taken to see that water in the locomotive does not freeze when the engine is shut down for any reason. If an "A" unit engine is shut down, but trainline steam is available, open steam admission valves into engine and "G" valve on the cooling water supply tank. The steam admission valve is located on engineroom floor at left front corner (governor end) of engine. Do not confuse this valve with the engine drain valve. Close valve 3 and open valves 2 and 7, Fig. 2-10. Valve 4 should be closed, valve 9 cracked open to allow condensate to drain. On a "B" unit it is only necessary to open the steam admission valve to the engine and the "G" valve to accomplish the same purpose. If trainline steam is not available, the entire system will have to be drained.

- A. If the engine and steam generator are inoperative and steam from an external source is supplied to prevent freezing, the following valves are to be opened:
 1. Engine cooling system.
 - a. Steam admission valve to engine cooling water
 - b. Steam supply valve to cab heaters.

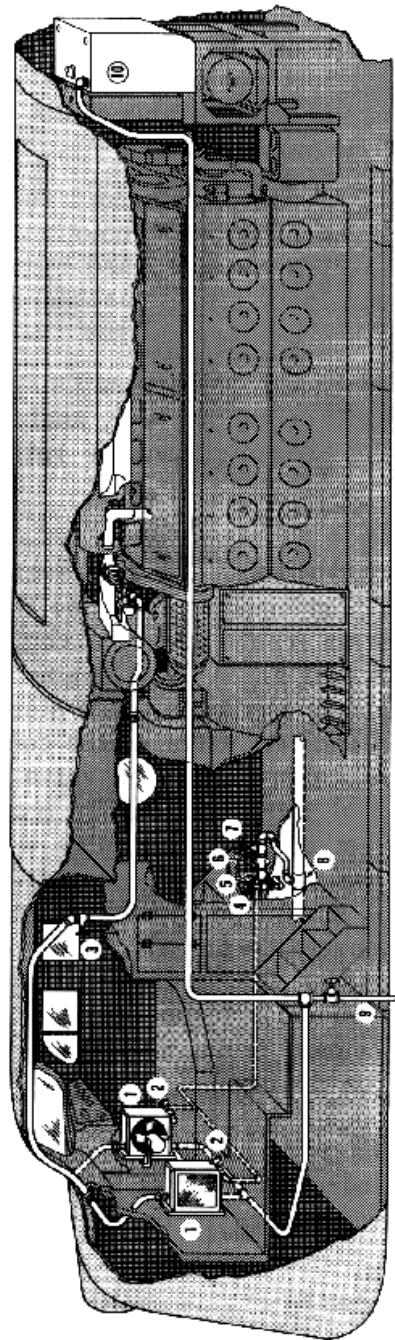

- | | |
|-------------------------------------|----------------------------------|
| 1. Cab Heaters | 6. Steam Pressure Reducing Valve |
| 2. Cab Heater Steam Valves ⊕ | 7. Steam Admission Valve ⊕ |
| 3. Cab Heater Valve | 8. Steam Trainline Connection |
| 4. Steam Heating Line Drain Valve ⊕ | 9. Cab Heater Drain Valve ⊕ |
| 5. Check Valve | 10. Engine Cooling Water Tank |
- ⊕ Normally Closed

Cab Heating System
Fig. 2-10

- c. "G" valve.
- d. Toilet water tank steam valve.
2. Steam generator.
 - a. Heating coil valve.
 - b. Water suction line valve.
 - c. Water tank valve.
- B. In freezing weather if heating facilities are not available, all water must be drained from:
 1. Engine cooling system and cab heaters. Also, open the drain in the bottom of the right water pump housing to prevent its freezing.
 2. Steam generator.
 3. Steam generator water tank.
 4. Toilet water tank.
 5. Air system.
 - a. Air compressor oil separator.
 - b. Sump reservoirs.
 - c. Main reservoirs.
 - d. Type H filter.
 - e. Electrical control air regulator.
 - f. Electrical control air reservoir.
 - g. Strainers at engine control and instrument panel, and electrical control cabinet.
 - h. Air compressor intercooler.

222 Operation Over Railroad Crossings The throttle should be reduced to the 5th notch before reaching railroad crossings and reopened after all units have passed over crossing. This will reduce arcing of the brushes on the traction motor commutators.

223 Running Through Water Under ABSOLUTELY NO circumstances should the locomotive pass through water which is deep enough to touch the bottom of traction motor frames. When passing through water, always go at a very slow speed (2 to 3 miles per hour).

Water any deeper than three inches above the top of the rails is likely to cause damage to the traction motors.

224 Resetting PC Switch After Safety Control Application

1. CLOSE THROTTLE TO IDLE.
2. Place automatic brake valve in LAP.
3. Place foot on safety control foot pedal.
4. Wait until application pipe is normal. Listen for exhaust or watch PCS light. If the PC switch does not reset itself with the automatic brake valve handle in LAP, move the brake valve handle to the RUNNING position. The PC switch is properly set when the light goes out.
5. Reset train control.
6. Release brakes.

225 Ground Relay Action When the ground relay is tripped the engine will not speed up when throttle is opened and no power will be developed; the alarm bell will ring and the ground relay light (White) on the engineman's control panel will be on. If the ground relay trips, while the throttle is in Run 5 or 6, the engine will stop. To reset, isolate engine, depress relay reset button and put engine "on the line." If relay continues to trip, isolate unit.

226 Wheel Slip Indication The wheel slip light will flash on immediately when a pair of wheels has slipped. The detection of wheel slip action automatically reduces the application of power to stop the slipping; the power will be reapplied after the slipping has stopped.

It will generally be unnecessary to reduce the throttle because of momentary wheel slip action. Sand may be applied to prevent repeated wheel slipping which may occur under extremely poor rail conditions.

227 Indication Of A Pair Of Wheels Sliding If one pair of wheels should slide when starting a train, the wheel slip light will flash on and off intermittently. As the train speed increases, the light will stay on more or less continuously and will not go out when the throttle is reduced. The light will go out when throttle is closed to idle.

If sliding is suspected, the engine crew should make an immediate investigation to determine the cause. The wheels may be sliding due to a locked brake, a broken gear tooth wedged between the pinion and ring gear, etc.

Repeated ground relay action, accompanied with unusual noises such as continuous thumping or squealing, may also be an indication of serious traction motor trouble that should be investigated at once.

IF AN ENGINE MUST BE ISOLATED BECAUSE OF REPEATED WHEEL SLIP OR GROUND RELAY ACTION, DO NOT ALLOW THAT UNIT TO REMAIN IN THE LOCOMOTIVE CONSIST UNLESS IT IS CERTAIN THAT ALL WHEELS ARE ROTATING FREELY.

228 Air Box Drains The engine air box accumulation settles in two drain tanks incorporated in the engine oil pan near the generator end, one on each side. Two air box drain valves, Fig. 2-11, permit draining of these tanks. The tanks should be drained periodically when the locomotive is standing still. With the air box drain valves open, observe the drain pipe discharge under the locomotive to determine if there is any water or an

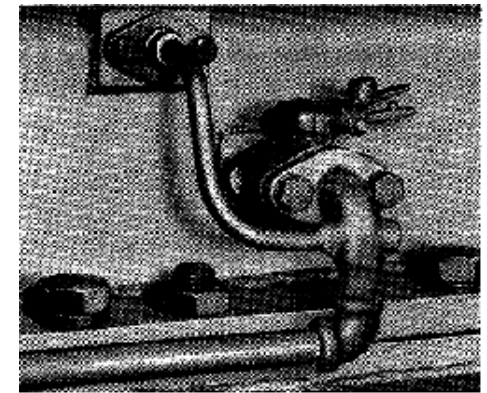

**Air Box Drain Valve
Fig. 2-11**

excessive oil accumulation in the air box. If a discharge is observed from the drain pipes under the locomotive with the air box drain valves closed (accumulation flowing through overflow pipe), the air box accumulation should be investigated.

OPERATION OF LOCOMOTIVE "EXTRAS"

F9 type locomotives can on special order be equipped with dynamic brakes, motor lockout switches and hostler's controls.

229 Dynamic Brake Operation Dynamic braking is an electrical hookup used to change some of the power developed by the momentum of a moving locomotive into an effective holding brake. The traction motor armatures, being geared to the axles, are rotating whenever the train is moving. When using dynamic brake, electrical circuits are set up which change the traction motors into generators. Since it takes power to rotate a generator, this action retards the speed of the train. The dynamic brake is, in effect, very similar to an independent brake, and the load indicating meter serves the purpose of a "brake cylinder pressure gauge."

In descending a grade, with the throttle in Idle position, the drawbar "push" of the trailing train tonnage moves the locomotive forward. If no resistance other than the weight of the locomotive and wheel friction is exerted against this "push," the momentum of the train on the descending grade would soon reach a speed where the train brakes would have to be applied. In dynamic brake, a resistance to this drawbar push is set up which in effect "holds back" the speed of the train as would the application of the locomotive independent brake. The effect of the resistance is to slow down the traction motor armatures being driven by the "push" of the train.

The resistance set up in each traction motor is a magnetic field through which the traction motor armature must rotate. Increasing the strength of the magnetic field will effect a "slowdown" of the traction motor armature, thus holding back the train. The magnetic field is produced by connecting the traction motor fields of each unit in series with the main generator and passing a current through these fields. The strength of the magnetic field is varied by varying the main generator current to the traction motor fields in each unit.

The main generator battery field of each unit in the locomotive consist is connected in series to the low voltage supply of the lead unit. This is called the "field loop" circuit. Movement of the selector lever in the lead unit into the "B" braking position, sets up the controller for the throttle lever to control the position of the load regulator which in turn regulates the main generator battery field current for dynamic braking. The throttle moves a 500 ohm rheostat which acts through a micropositioner relay (LRP), Fig. 2-12, to position the load regulator. Moving the throttle lever toward the 8th notch and away from idle increases the effectiveness of the "holding brake." Thus, in effect, the strength of the traction motor field through which the traction motor armature must rotate, is controlled by the throttle lever.

In dynamic brake, the traction motor armatures are connected to grids located in the top of the carbody. Rotation of the armature through the magnetic field generates power (braking current) and this current flows through the grids to be dissipated as heat. The current generated increases as the armature

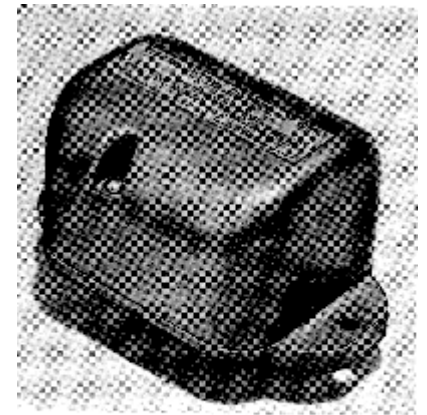

**Micropositioner
Fig. 2-12**

rotation increases (momentum of train increases the drawbar push) or as the strength of the magnetic field is increased. The maximum braking current that can flow through the grids is automatically limited to 700 amperes regardless of locomotive speed or throttle lever position.

To operate the dynamic brake on locomotives so equipped, proceed as follows:

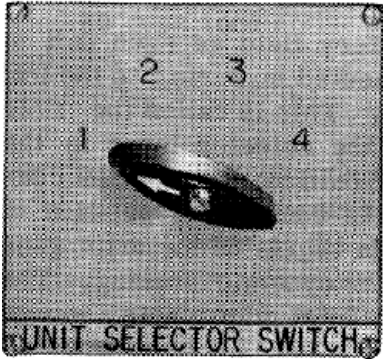

Unit Selector Switch
Fig. 2-13

1. Position the unit selector switch, Fig. 2-13, in the lead unit to correspond to the number of units in the locomotive consist.
2. Reverse lever should be positioned in the direction of locomotive movement.
3. Throttle must be reduced to Idle.
4. Move selector lever from "No. 1" to "Off" position; pause 10 seconds before proceeding.
5. Move selector lever to the "B" position. In this position, the brake transfer switch (BKT) is moved to the "brake" position. Movement of the "BKT" to "brake," disconnects the traction motor armatures from the motor fields and connects the armatures to the grids. In each unit the traction motor fields are connected to the main generator through the power contactors. The battery field of all main generators in the consist are in series with the low voltage supply of the lead unit.
6. After slack is bunched, the throttle lever may be moved to position the rheostat to give the desired amount of braking effort. (The speed of the Diesel engine is increased from 275 RPM

- (Idle) to 435 RPM automatically as the throttle handle is moved about 13° away from Idle.)
7. Observe the braking amperage (braking effort) on the load indicating meter. The braking amperage is automatically limited to a maximum braking effort of 700 amperes regardless of locomotive speed or throttle handle position.
 8. If maximum braking is desired, the throttle handle should be moved to the full "8th notch" position. The throttle handle should always be moved SLOWLY to prevent a sudden surge of current in excess of the maximum brake current rating. Generally, if the throttle handle is moved slowly to the full "Braking" position, the brake current limiting regulator will limit the braking current to a maximum 700 amperes and no brake warning indication of excessive braking current will be given. However, if the brake warning light flashes on, movement of the throttle handle should be stopped until the light goes out. If the light fails to go out after several seconds, move throttle handle back toward "Idle" position slowly until the light does go out. After the brake warning light goes out, the throttle handle may again be advanced slowly toward the full "8th notch" position.
 9. When necessary, the automatic brake may be used in conjunction with the dynamic brake. However, the independent brake must be KEPT FULLY RELEASED whenever the dynamic brake is in use, or the wheels may slide. As the speed decreases below 10 miles per hour the dynamic brake becomes less effective. When the speed further decreases, it is permissible to completely release the dynamic brake by placing the selector lever in the "OFF" or No. 1 position, applying the independent brake simultaneously to prevent the slack from running out.

NOTE: The most effective use of the dynamic brake is between 15 and 25 miles per hour depending on the gear ratio. Speed on grades should not be allowed to "creep up" by careless handling of the brake, as this is a holding brake and is not too effective in slowing down heavy trains on steep grades.

These locomotives can be operated in dynamic braking coupled to older units that are not equipped with brake current limiting regulators. If all the units are of the same gear ratio, the unit having the lowest maximum brake current rating should be placed as the lead unit in the consist. The engineman can then operate and control the braking effort up to the limit of the unit having the lowest brake current rating, without overloading the dynamic brake system of a trailing unit. The locomotive consist MUST always be operated so as not to exceed the braking current of the unit having the lowest maximum brake current rating.

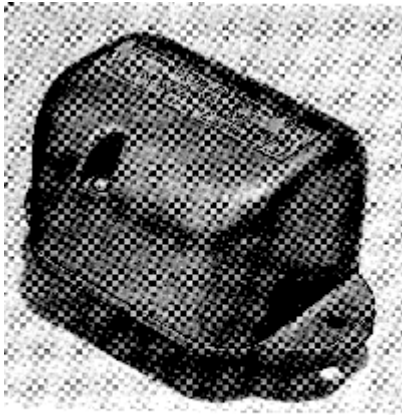

**Micropositioner
Fig. 2-12**

Units equipped with dynamic brake current limiting regulators and of different gear ratios will require special operating instructions when used in multiple with an F9 type locomotive in dynamic braking.

230 Dynamic Brake Selector Switch The dynamic brake unit selector switch, Fig. 2-14, located at the engineman's control station, has four positions (1, 2, 3 and 4) and should be set to correspond with the

number of units in the locomotive consist. This switch should be set before leaving the terminal and must not be changed even if an engine is isolated enroute. This switch is changed only if the number of units in the locomotive consist is changed.

231 Dynamic Brake Warning Light The dynamic brake warning light on the engineman's instrument panel will flash on when an excessive braking current is developed. Generally, the over-current is only temporary, and the dynamic brake current limiting regulator will automatically reduce the braking current to a maximum 700 amperes.

232 Dynamic Brake Grid Blower The braking current, generated by the traction motors in dynamic braking, flows through the grids to be dissipated as heat. The grids are cooled by a motor driven fan, Fig. 2-15. The grids and fan are located in the top of the carbody above the main generator and air compressor. Power generated by the No. 1 and No. 3 traction motors drives the grid blower motor.

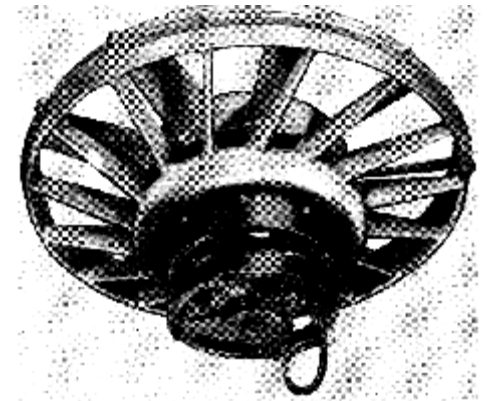

**Dynamic Brake Grid Blower
Fig. 1-15**

233 Dynamic Brake Wheel Speed Control The relays, used to correct a wheel slip while under power, are also used to correct the tendency of one pair of wheels to rotate slower while in dynamic braking due to an unusual rail condition.

When a pair of wheels is detected tending to rotate at a slower speed, the retarding effort of the traction motors in the unit affected is reduced (main generator battery field excitation is reduced in the unit affected) and sand is automatically applied to the rails ("Automatic Sanding" switch on engineman's control panel must be "ON" position). When the retarding effort of the traction motors in the unit is reduced, the tendency of the wheel set to rotate at a slower speed is overcome. After the wheel set resumes normal rotation, the retarding effort of the traction motors returns (increases) to its former value. Automatic sanding continues for approximately 10 seconds after the wheel speed is corrected.

234 Hump Speed Control When used, the electrical hump speed control circuit controls the positioning of the load regulator in order to maintain constant locomotive speed regardless of the number of cars in the train. The hump speed controls are shown in Fig. 2-16. To set the hump control circuit, Fig. 2-17, into operation, bring the throttle out as far as possible, consistent with desired train speed and



Hump Speed Control
Fig. 2-16

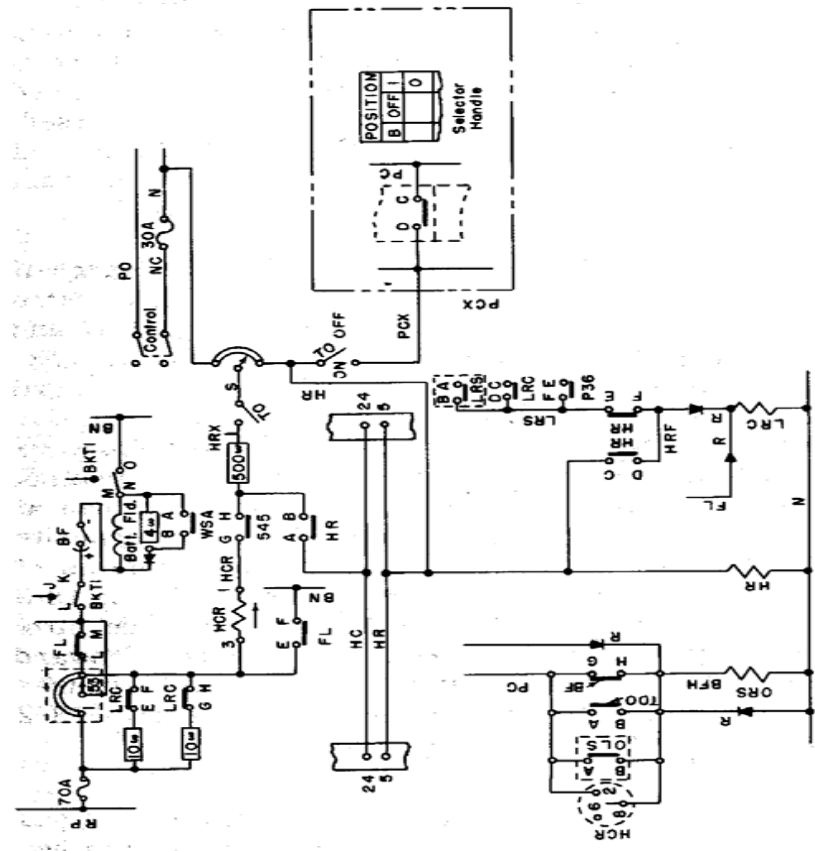

Schematic Hump Control Circuit
Fig. 2-17

adequate cooling air to the traction motors. Leave it in that position for the remainder of the hump operation. Turn the hump control toggle switch to its ON position and adjust the rheostat knob, Fig. 2-16, to give the exact desired speed. Once the desired train speed is reached, there should be no need to move the knob again. If an extremely long train is to be handled, it may be necessary to trim the amount of battery field excitation to reduce speed after a substantial number of cars have been released. This can be accomplished by turning the hump control rheostat slightly toward decrease until the desired train speed is regained.

As shown in Fig. 2-17, the hump control circuit is a bridge type, between the two ends of the hump control rheostat on one side and the load regulator and battery field on the other side. The Diesel engine governor pilot valve tries to force the load regulator toward maximum field in an effort to load the engine by increasing main generator excitation. This action continues until the potential at point 1 of the hump control relay (HCR) is approximately 1/2 volt greater than at point 3. The current flow then travels in the opposite direction through the HCR causing the 8-2 contacts of the HCR to close which completes a circuit to the ORS solenoid in the governor. The ORS acts upon the pilot valve of the governor forcing the load regulator toward minimum field until the potential across 1 and 3 causes the HCR to "drop out." As the HCR drops out the 8-2 contacts open and another cycle begins.

In order that full load regulator effectiveness can be utilized, a hump relay (HR) becomes energized when the hump control toggle switch is turned to its ON position. The A-B interlocks of HR complete a circuit to the load regulator control relay (LRC). The E-F interlocks of LRC in turn open to remove the resistance from around the load regulator.

235 Motor Lockout Switches Four motor lockout switches (CO1, C02, C03, and C04) are mounted on the reverser drum, Fig. 2-18. Each switch permits the isolation of the corresponding traction motor from the power circuit (CO1 cuts out traction motor No. 1) in the event that a traction motor is grounded. Always isolate the engine before opening a motor lockout switch. Not more than one traction motor should be cut out at any time, and the armature of the traction motor cut out must be free to rotate.

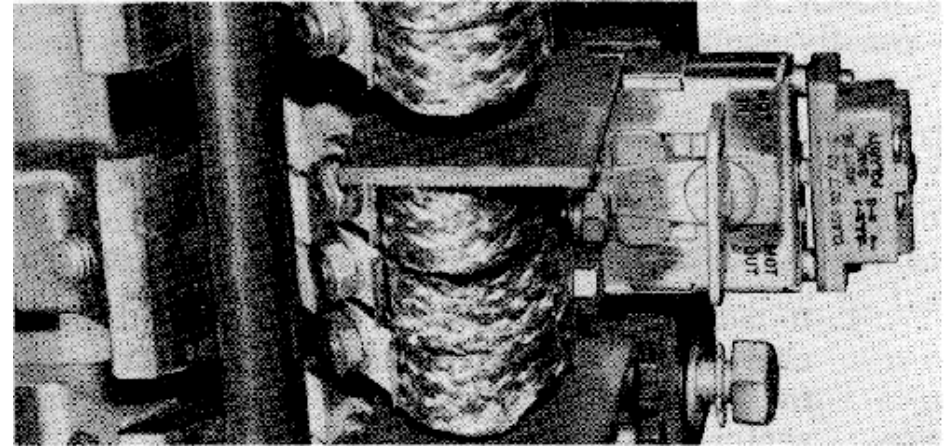

Motor Lockout Switch

Fig. 2-18

236 Operating "B" Unit With Hostler's Controls Operation at the hostler station is the same as an "A" unit. The switches are beside the controller. The brake valve cutout cock is below the brake valve. The bell valve is a globe valve near the controller. Only No. 1 transition is available. Movement of the reverse lever automatically places the locomotive in No. 1 transition. It should be remembered that the operation of the "B" unit controls will operate all units joined to it.

When securing the hostler control, be sure all switches are open, the controller and reverser pinned, and the brake valve cut out, as these items can affect operation at any other station or cab.

237 Safety Control Foot Pedal The safety control foot pedal (if used) is located in front of the engineman's seat. On locomotives equipped with a hinged automatic brake valve handle, the handle provides an alternate control when it is depressed sufficiently to just contact the sanding bail. Either the pedal or the automatic brake valve handle must be kept depressed at all times except when the locomotive is stopped and the locomotive brakes are applied (30 pounds or more brake cylinder pressure). If both the foot pedal and the automatic brake valve are released at the same time, a penalty application of the brakes will result.

238 Brake Pipe Flow Indicator A brake pipe flow indicator is a very useful supplement to locomotive air brake equipment. The indicator provides the engineman with the following desirable indications:

1. It indicates a train line that is sufficiently charged to start the initial brake test when the differential between the pointer hand and sector hand reaches 7 pounds or less.
2. It indicates the continuous system leakage of the particular train being handled. This indication is the lowest number reached after the train is fully charged, the reading should be 5 or less.
3. A change in reading from the number indicated as a normal continuous system leakage indicates one of the following conditions:
 - a. Conductor initiated Service Reduction from the caboose.
 - b. Conductor initiated Emergency Application from the caboose.
 - c. An application caused by a break-in-two or separation of the train.
4. This indicator provides readings in lap position of the brake valve from 50 to 110#, as well as differential indication in running position of the brake valve. Therefore, it may be used

conveniently when checking brake pipe leakage in lap position.

5. Only practice and experience will bring out all the uses of this indicator. Some of the troubles which can be detected are faulty feed valve operation, leaks in the rotary valve seat, and other potential brake valve failures.

The flow indicator consists of a duplex gauge case and bezel with a special movement, and employs bourdon tubes with enough sensitivity to indicate differentials encountered during the various brake operating conditions. This is accomplished by measurement of differential pressures across the feed valve, which would indicate the degree of work the feed valve was required to do in order to supply the demand of the brake pipe.

Figs. 2-19 through 2-24 explain the use of the indicator by illustrating the position assumed by the gauge under various conditions.



Uncharged Train Or
Dead Brake Pipe
Fig. 2-19



Partially Charged Train,
Or Reduction Made From
Rear End Of Train
Fig. 2-20

SECTION 3

LOCATION AND CORRECTION OF
DIFFICULTIES ON-THE-ROAD

This section provides a check list calling the operator's attention to the troubles which are most frequently encountered on the road, and which can be quickly remedied thereby eliminating many delays.

No attempt is made to explain general operation and functions of equipment on the locomotive. For such information refer to the other sections of this manual.

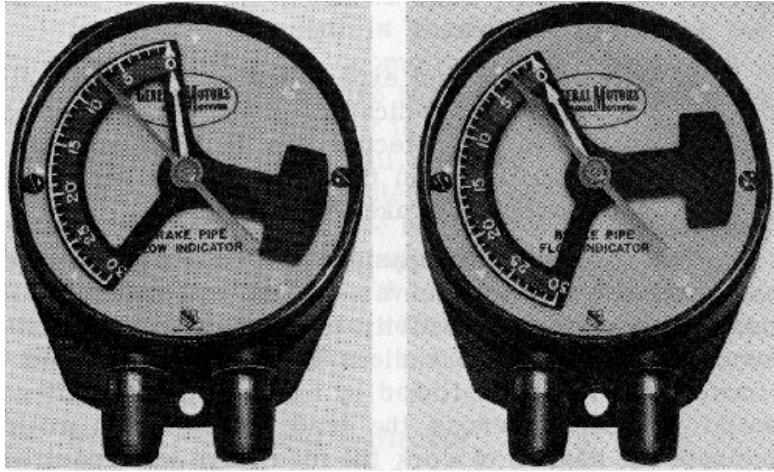

Brakes Released And
Train Charged, Ready For
The Initial Brake Test
Fig. 2-21

Continuous Leakage In
A Charged Train
Fig. 2-22

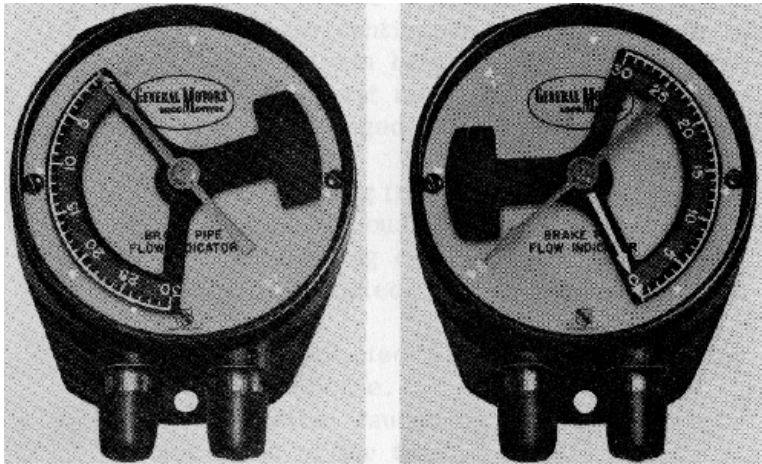

Charged Brake Pipe
With No Leakage
Fig. 2-23

After An Emergency
Application
Fig. 2-24

300 General Safety devices automatically protect the equipment in case of the faulty operation of most any component. In general, this protection is obtained by unloading or preventing the loading of the Diesel engine so that the locomotive loses its pulling power. The locomotive can lose its power with the Diesel engine still running. An exception is a hot engine alarm, which does not reduce the engine load or speed.

When trouble is experienced, the general location and type of difficulty is often indicated by the ringing of an alarm bell and the lighting of one or more signal lights in the troubled units. The signal lights are as follows: RED - Hot Engine; GREEN - Boiler Stopped; BLUE - Alternator Failure; YELLOW - Low Oil; and WHITE - PC Switch.

301 If Alarm Bells Ring One or more of the signal lights will be illuminated in the unit affected, Fig. 3-1.

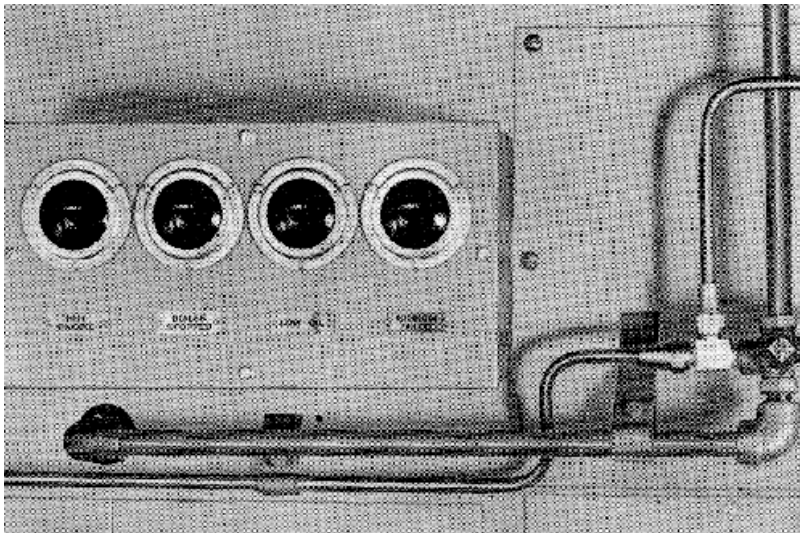

Alarm Lights
Fig. 3-1

RED - Hot Engine This alarm light indicates that the outlet engine water temperature is about 208° F. A hot engine alarm does not reduce the engine load or speed. The alarm signal will not stop until temperature returns to normal. In case of hot engine alarm, proceed as follows:

1. Isolate engine. Isolating the engine will not stop alarm bell; temperature must return to normal.
2. Check engine cooling water tank for correct level, Fig. 3-2. If there is sufficient water in the system, allow engine to run at IDLE speed.

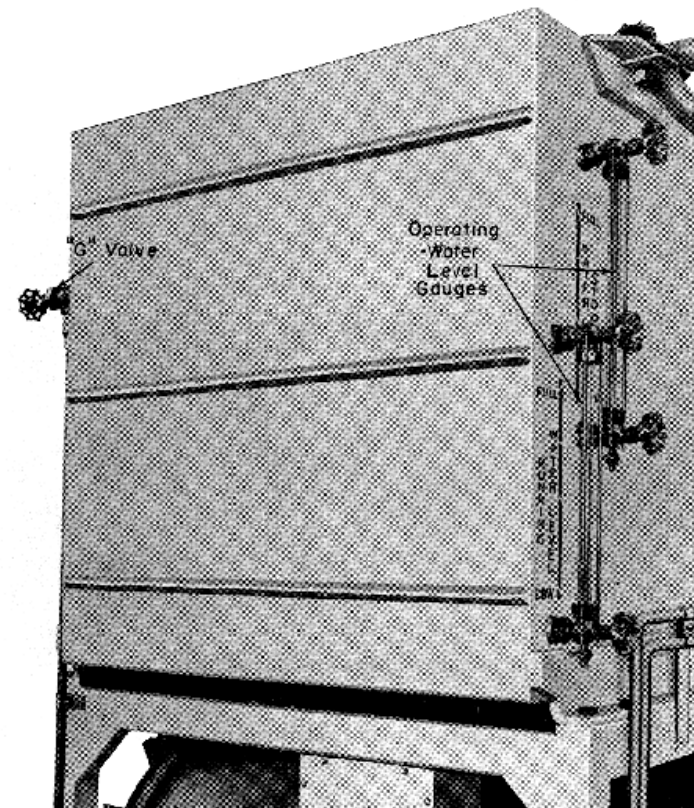

Cooling Water Level
Fig. 3-2

3. See that all AC cooling fan contactors are closed, Fig. 3-3.
4. See that the shutters are open. If closed, check position of "shutoff" valve in the air supply pipe to the shutter magnet valve.
5. See that the "Control" switch is ON.

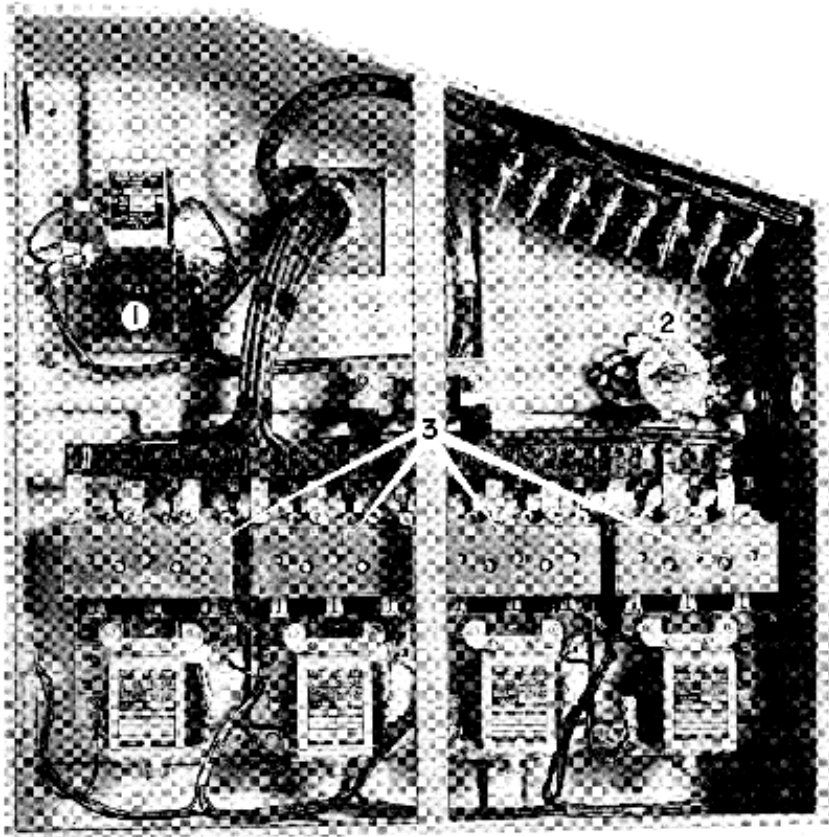

1. Temperature Control Relay
2. Summer-Winter Switch (SWS)
3. AC Cooling Fan Contactors

AC C Contactor Panel
Fig. 3-3

GREEN - Boiler Stopped Indicates steam generator has stopped. To stop alarm signal, turn boiler switch OFF, Fig. 3-4.

BLUE - Alternator Failure This alarm signal indicates that the alternating current system has failed; traction motor blowers and radiator cooling fans have stopped; No Voltage Relay (NVR) is opened (de-energized), Fig. 3-5. The engine speed and load is automatically reduced equivalent to No. 1 throttle position. The engine will STOP if the "AC" system fails with the throttle in Run 5 or 6. Placing the isolation switch in START stops the alarm signals.

Most "Alternator Failure" alarms are "false" since this alarm occurs if the engine is stopped for any reason while "on the line." With an "Alternator Failure" alarm and the engine stopped, ALWAYS isolate and check cause of engine stopping. Check:

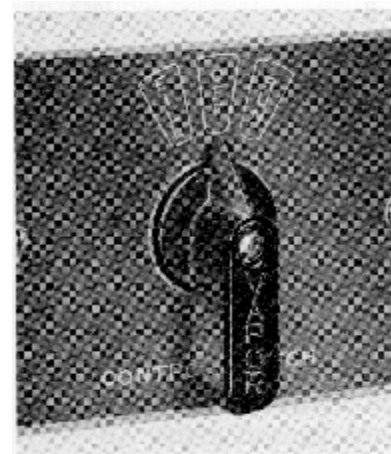

Boiler Switch
Fig. 3-4

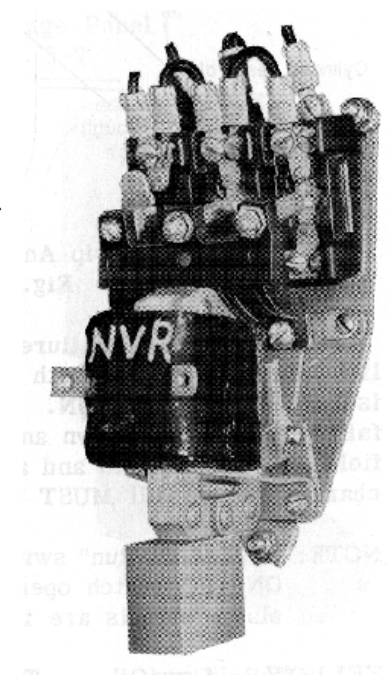

NVR Relay
Fig. 3-5

overspeed trip, throttle must not be in STOP position, and fuel flow through fuel return sight glass, Fig. 3-6, before trying to start an engine that has shut down with no indication other than an "Alternator Failure" alarm. If other alarm indications are present with the "Alternator Failure" alarm, they must also be checked before starting the engine.

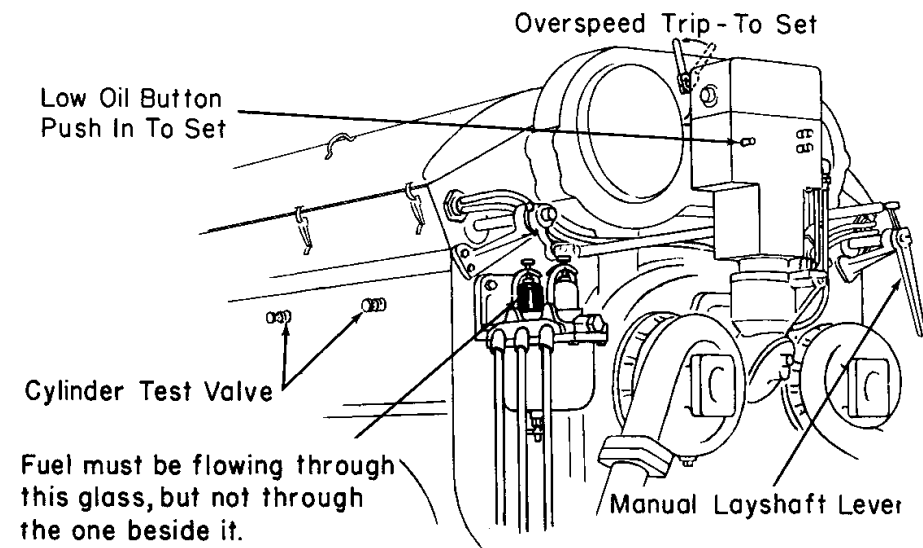

Overspeed Trip And Fuel Flow Check
Fig. 3-6

A "TRUE" AC failure is evident when the Blue light and bell are ON with the engine running and the isolation switch in RUN. To correct a "TRUE" AC failure, shut engine down and check auxiliary generator field, alternator field and auxiliary generator (battery charging) fuses; all MUST be good. See Fig. 3-7.

NOTE: If "Engine Run" switch is OFF, or PC light is ON (PC switch open) the "Alternator Failure" alarm signals are inoperative.

YELLOW - Low Oil The tripping of the governor low oil alarm button, Fig. 3-8, due to engine low oil pressure or high oil suction, will

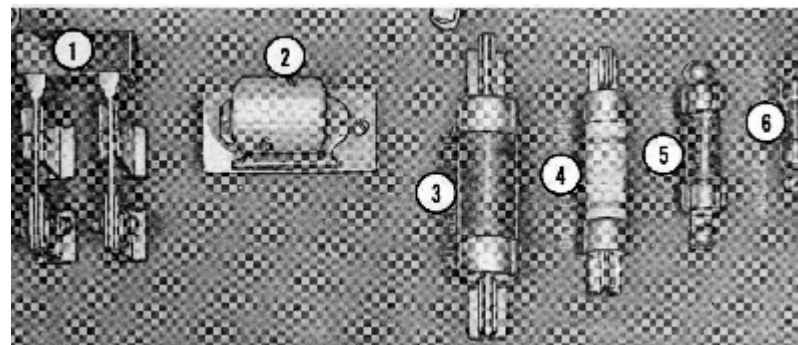

- | | |
|----------------------------------|---------------------------------------|
| 1. Auxiliary Generator Switch | 4. 80A Battery Field Fuse |
| 2. RCR - Micropositioner | 5. 35A Alternator Field Fuse |
| 3. 150A Auxiliary Generator Fuse | 6. 30A Auxiliary Generator Field Fuse |

Low Voltage Panel
Fig. 3-7

always stop the engine. The yellow indicating light will flash ON, and the alarm bell will ring if the "Engine Run" switch is ON.

To correct, proceed as follows:

1. Place isolation switch in START.
2. Reset low oil trip button.
3. Check engine lubricating oil level on engine oil pan dipstick, Fig. 3-9.
4. Check for broken or cracked oil lines

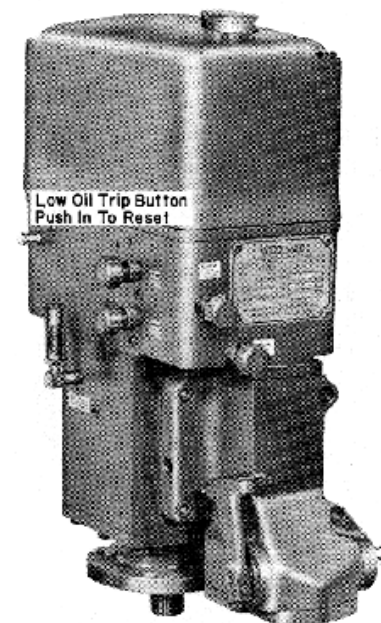

Lube Oil Button
Fig. 3-8

5. Restart engine.
6. Check oil pressure (must be a minimum of 6 psi at IDLE).

NOTE: Do not repeatedly start engine if the LOW OIL button keeps shutting the engine down.

ADDITIONAL SAFETY DEVICES

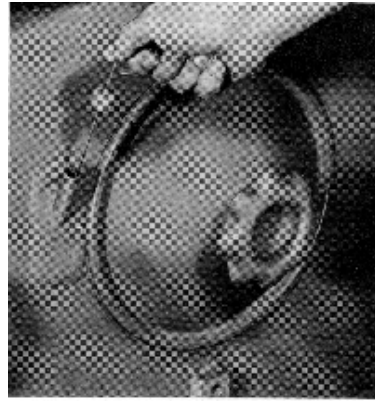

Engine Oil Pan Dipstick
Fig. 3-9

302 Ground Relay When the ground relay, Fig. 3-10, located on the cab side of the electrical cabinet, trips open, the engine speed and load will automatically be reduced to IDLE, or to STOP if the throttle is in Run 5 or 6.

To correct: Isolate engine, reset ground relay, start engine if necessary and place engine "on the line." If the ground relay continues to trip, reset, and leave engine isolated.

IF AN ENGINE MUST BE ISOLATED BECAUSE OF REPEATED WHEEL SLIP OR GROUND RELAY ACTION, DO

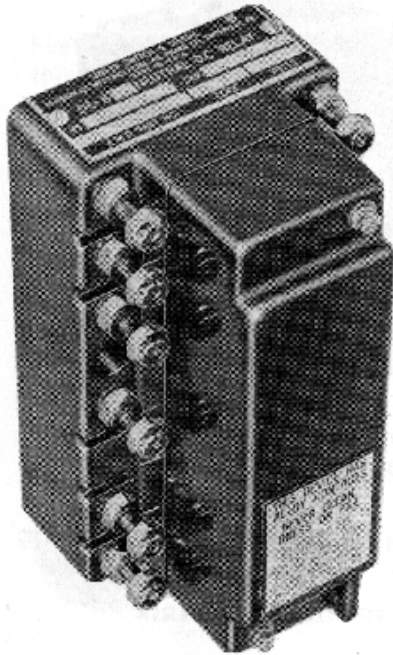

Ground Relay
Fig. 3-10

NOT ALLOW THAT UNIT TO REMAIN IN THE LOCOMOTIVE CONSIST UNLESS IT IS CERTAIN THAT ALL WHEELS ARE ROTATING FREELY.

303 "PC" Switch Open The "PC" switch is an air operated electric switch that is tripped open by any "penalty" or "emergency" air brake application. When tripped, the White "PC" light at the engineman's control station will flash on but the alarm bell will not ring. The engine speed and load are automatically reduced equivalent to throttle position No. 1. If the "PC" switch tripped open with the throttle in Run 5 or 6, the engine would stop. To automatically reset "PC" switch:

1. Close throttle to IDLE.
2. Place automatic brake valve in LAP.
3. Place foot on safety control foot pedal (if used).
4. Wait until application pipe builds up to normal pressure; listen for exhaust or watch "PC" switch light. If, after an emergency application, the "PC" switch does not reset itself with the automatic brake in LAP, move the brake valve to RUNNING. The "PC" switch is set when the light goes out.
5. Reset train control (if used).
6. Place automatic brake valve in RUNNING.

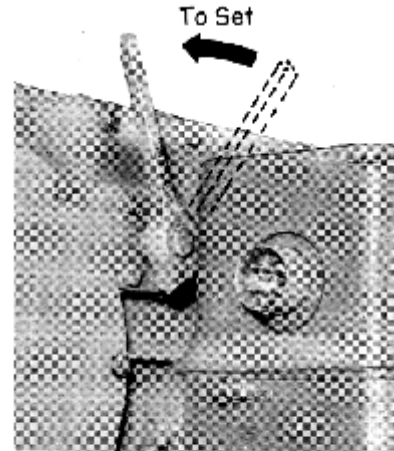

Overspeed Trip
Fig. 3-11

304 Engine Overspeed Trip Trip If the engine speed should exceed approximately 910 RPM an overspeed device, Fig. 3-11, located on the front end of the engine will trip and stop the

engine by preventing the injectors from injecting fuel into the cylinders. The alarm bell and Blue light will come on if the engine is stopped in this manner while "on the line." The overspeed trip must be latched in the SET position before the engine can be restarted.

305 Fuel Flow For proper operation, a good flow of fuel (clear and free of air bubbles) should be indicated by the fuel return sight glass, Fig. 3-12, located on the sintered bronze filter assembly.

If fuel is not flowing through return sight glass, check fuel pump motor. If motor is stopped, check: (1) in "lead" unit, the "Control" switch on the engineman's control panel MUST be ON, and the 30-ampere control fuse must be good, (2) "Fuel Pump" switch on engine control panel must be "ON," (3) 10-ampere fuel pump motor fuse and 80-ampere control fuse must be good in "troubled" unit, (4) control knife switch and main battery switch must be closed, and (5) for loose cable connections to motor. If pump is running but fuel is not pumped, check: (1) fuel supply, (2) position of emergency fuel cutoff valve, (3) a suction leak in piping, (4) clogged suction filter, (5) a slipping coupling at fuel pump.

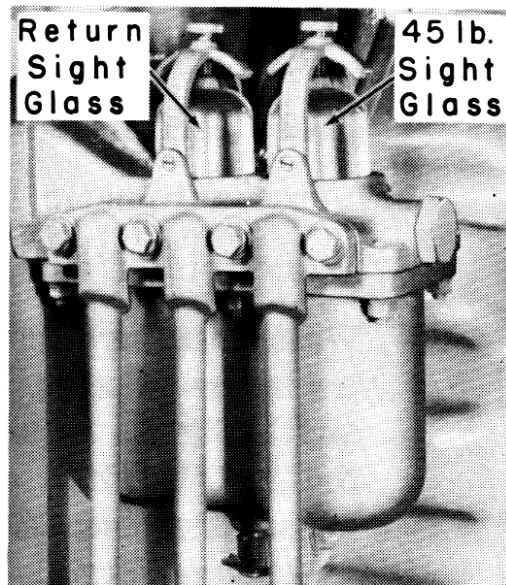

Fuel Sight Glasses

Fig. 3-12

306 Emergency Fuel Cutoff Valve Pulling any one of the three emergency fuel cutoff valve pull rings will shut off the fuel supply to the fuel pump (one is located in the operating cab of each "A" unit or on

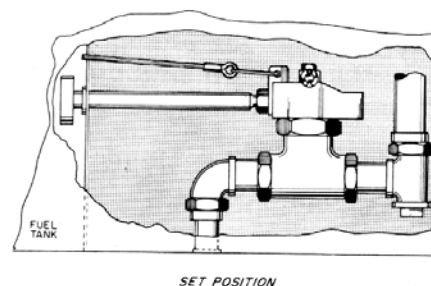
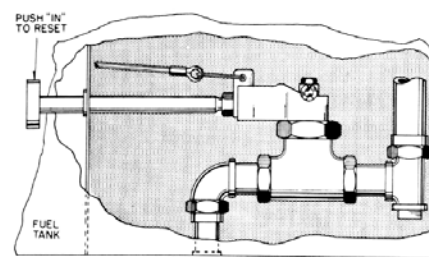

Emergency Fuel Cutoff Valve
Fig. 3-13

reopen the valve.

307 Control Air Pressure For satisfactory operation of the pneumatically operated contactors and switches used in the control circuit, the electrical control air pressure gauge in the electrical cabinet adjacent to distribution panel must indicate 90 ± 3 lbs. The pressure regulator, Fig. 3-14, is located behind the steps leading into the operating cab on the right (engineman's) side of the locomotive. To raise or lower the pressure, change the adjustment on top of regulator. A drain cock is provided on the bottom of the regulator for draining the moisture.

the engineroom wall at the governor end of the engine in each "B" unit, and one on each side of the locomotive near the fuel tank filler cap).

The cutoff valve is located on the underside of the fuel tank on the left side of the locomotive. Action of valve is as shown in Fig. 3-13. To reset, push in on the valve yoke "push rod" extension which can be reached from the left side of the unit. Pushing in on this rod as far forward as possible will

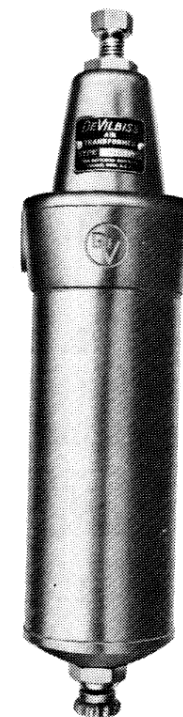

Air Regulator
Fig. 3-14

CORRECTION OF DIFFICULTIES**308 If The Engine Goes To Idle**

1. Ground relay might be tripped.
2. No voltage relay (NVR) might be open (Blue light will be ON).
3. PC" switch might be tripped.
4. "Engine Run" switch on the engineman's control panel might be OFF.
5. 15-ampere fuel pump fuse, in the "lead" unit may be burned out.
6. "Control" switch on the engineman's control panel might be OFF.
7. Isolation switch might be in "START."

309 If The Engine Stops

1. Throttle might be in STOP position.
2. Low oil pressure button on the governor might be OUT.
3. Engine overspeed device might have tripped.
4. No voltage relay (NVR) might have opened with throttle in RUN 5 or 6.
5. Ground relay might have tripped with the throttle in RUN 5 or 6.
6. "PC" switch might have tripped with the throttle in RUN 5 or 6.
7. No fuel flowing through "fuel return sight glass." See Art. 305, Fuel Flow, for possible causes of trouble.

310 How To Start Engine If the engine has been stopped for a considerable period of time, the cylinders should be tested for fuel or water accumulation before starting engine (see Art. 317).

1. Place throttle in Idle and reverse lever in Neutral.
2. Place isolation switch in the START position.
3. In the electrical cabinet, on the distribution and low voltage panels, see that all fuses are securely in place and that all knife switches are closed.
4. At the engineman's control panel, switch "ON" the "Control" and "Engine Run" switches.
5. Place "Fuel Pump" switch on engine control panel in "ON" position.
6. After allowing a few seconds for fuel to flow through return sight glass, Fig. 3-12, solidly press the "START" button and hold until the engine starts. If the engine fails to start after 15 seconds of rotation, check possible troubles listed under Art. 311-312 before again trying to start engine.
7. After allowing time for the lube oil pressure to build up, place isolation switch in the RUN position.
8. Check ground relay.

311 If The Engine Does Not Rotate When "Start" Button Is Pressed

1. "Control" switch on engineman's control panel and "Fuel Pump" switch on engine control panel must be ON.
2. Isolation switch must be in the START position.

3. 400-ampere starting fuse, 30-ampere control fuse and 80-ampere control fuse must be good. 4. Main battery switch and the control knife switch in the electrical cabinet must be closed.

312 If The Engine Rotates But Does Not Start When "Start" Button Is Pressed

1. Low oil pressure button on the governor must be pressed IN.
2. Engine overspeed trip must be "Set."
3. No fuel flowing through "Fuel return sight glass." See Art. 305, Fuel Flow, for possible causes of trouble.

313 If The Engine Does Not Speed Up When Throttle Is Opened

1. "Control" and "Engine Run" switches on engineman's control panel must be ON.
2. Isolation switch must not be tripped. 3. PC switch must not be tripped.
4. Ground relay must not be tripped.
5. No Voltage Relay (NVR) must not be open.
6. 15-ampere fuel pump fuse must be good.
7. No fuel flowing through "Fuel return sight glass." See Art. 305, Fuel Flow, for possible causes of trouble.

- 40 -

314 Engine Speeds Up But Locomotive Does Not Move When Throttle Is Opened

1. Reverse lever must be in either forward or reverse position.
2. Reverser drum switch must not be locked in neutral.
3. "Generator Field" switch on engineman's control panel must be ON.
4. There must be 90 pounds (\pm 3 lbs.) control air pressure.
5. Selector lever must be in No. 1 position.
6. Hand brakes and air brakes must be released.
7. 80 -ampere battery field fuse must be good.

315 Battery Ammeter Shows Continual Discharge, Fig. 3-15

1. Battery charging contactor located in the electrical cabinet must be closed.

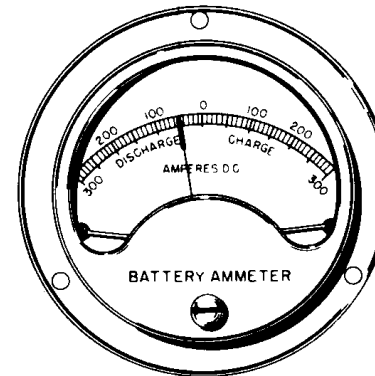

**Battery Ammeter
Fig. 3-15**

2. 250 - ampere auxiliary generator (battery charging) fuse must be good.
3. The "Auxiliary Generator Field" fuse in the electrical cabinet must be good.
4. The auxiliary generator knife switch in the electrical cabinet must be closed.

- 314 -

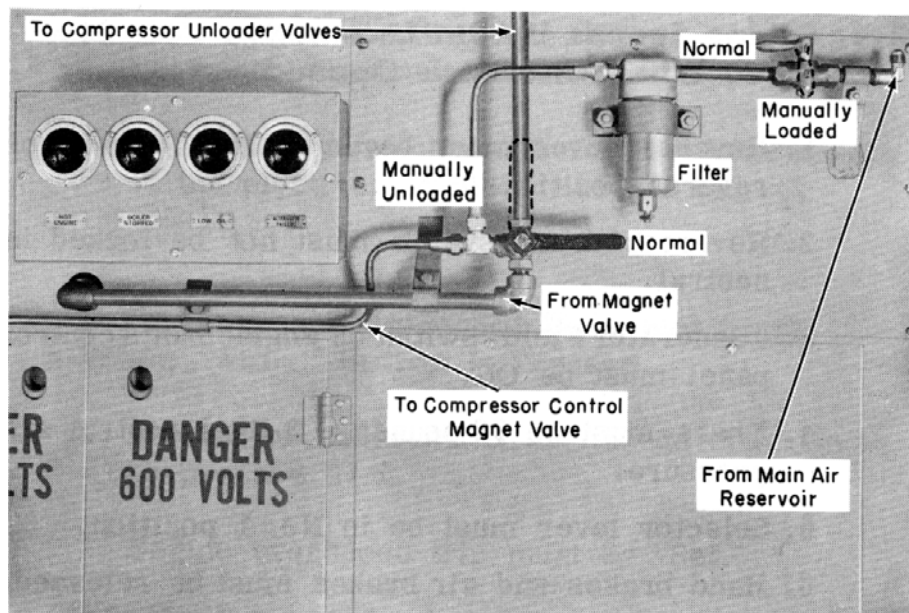

Manual Unloader Valve
Fig. 3-16

316 Compressor Control The air compressor on the locomotive is automatically controlled by an electro-pneumatic system which will normally keep the main reservoir pressure between 130-140 p.s.i. In the event of difficulty, the normal position of either of the valves, Fig. 3-16, may be changed to manually load or unload the air compressor in the troubled unit.

317 Cylinder Test Valves Each cylinder is equipped with a test valve, Fig. 3-17, for the purpose of testing for fuel or water accumulation in the cylinders prior to starting an engine that has been shut down for a considerable period of time.

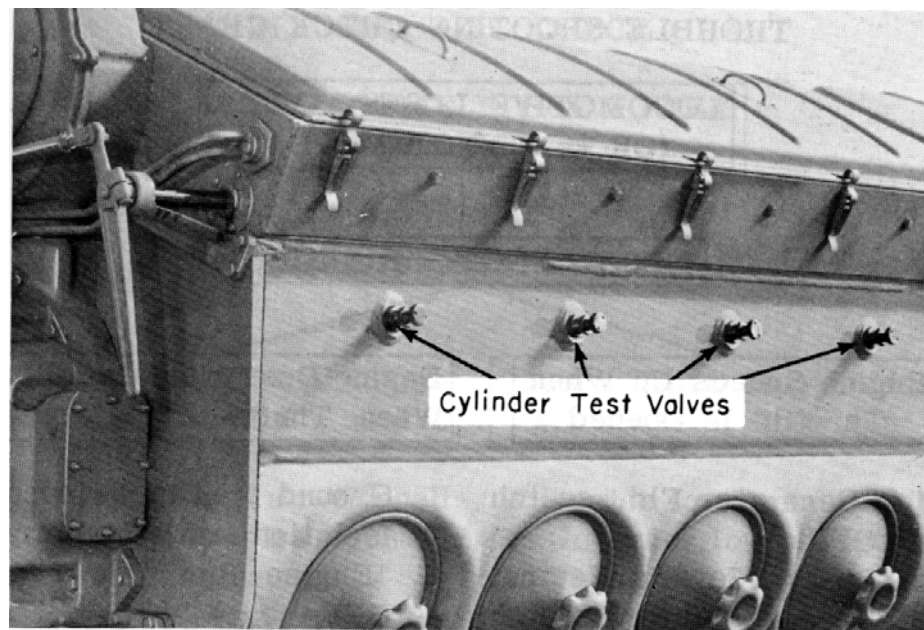

Cylinder Test Valves
Fig. 3-17

To make this test, remove the 400-ampere starting fuse, open all cylinder test valves approximately 3 full turns, and use the engine jacking tool to rotate the engine one complete revolution. If liquid is discharged from any cylinder, investigate; if not, close cylinder test valves, replace 400 ampere starting fuse, and start engine in the usual manner.

If the engine is running and any cylinder test valve is heard to be leaking, the engine should be stopped, and the valve(s) should be tightened.

TROUBLE SHOOTING CHECK CHART

LOCOMOTIVE LOSES POWER
(OR DOES NOT MOVE)
DIESEL ENGINE RUNNING

Engine Speeds Up When
Throttle Is Opened

1. "Generator Fld." switch OFF
2. Reverse lever in Neutral
3. Reverser drum switch (in electrical cabinet) locked in Neutral
4. Selector lever in OFF position
5. Control air pressure low
6. 80 amp. batt. fld. fuse
7. Brakes set

Engine Does Not Speed Up
When Throttle Is Opened

1. Ground relay tripped
2. Isolation switch in Start
3. "Engine Run" switch OFF
4. "Control" switch OFF
5. "PCS" light ON
6. "NVR" light ON
 - a. Auxiliary generator field fuse blown
 - b. Alternator field fuse blown
 - c. Auxiliary generator output fuse burned out
7. Control knife switch out
8. Loose governor cable

ADDITIONAL SAFETY DEVICES
NOT AFFECTING LOCOMOTIVE LOSS OF POWER

1 Hot Engine Alarm

1. Cooling water level low
2. AC cooling fan contactors opened
3. Shutters not opened

Steam Boiler Stopped Alarm

1. Motor overload tripped
2. Stack switch tripped
3. Coil blowdown valve open

TROUBLE SHOOTING CHECK CHART

LOCOMOTIVE LOSES POWER
(OR DOES NOT MOVE)

DIESEL ENGINE STOPPED

Causes Which Stop Engine
Only In Throttle 5 and 6

1. Ground relay tripped
2. "NVR" de-energized
3. "PCS" actuated
4. "Engine Run" switch OFF

Fuel Pump Motor
Stopped

1. Main battery switch OPEN
2. "Control" knife switch OPEN
3. 80 amp. Control fuse BLOWN
4. "Control" switch OFF
5. "Fuel Pump" switch at Engine Control Panel tripped OPEN
6. Loose fuel pump cable

Causes Which Stop Engine
All Throttle Positions

1. Engine overspeed trip
2. Governor low oil button
3. Throttle in Stop position
4. Lack of fuel

Fuel Pump Motor
Running

1. No fuel supply
2. Emergency fuel "cutoff" tripped
3. Clogged suction filter
4. Clogged sintered bronze filters
5. Loose fuel pump coupling
6. Broken fuel suction line

SECTION 4

COOLING, LUBRICATING OIL, FUEL OIL AND AIR SYSTEMS

COOLING SYSTEM

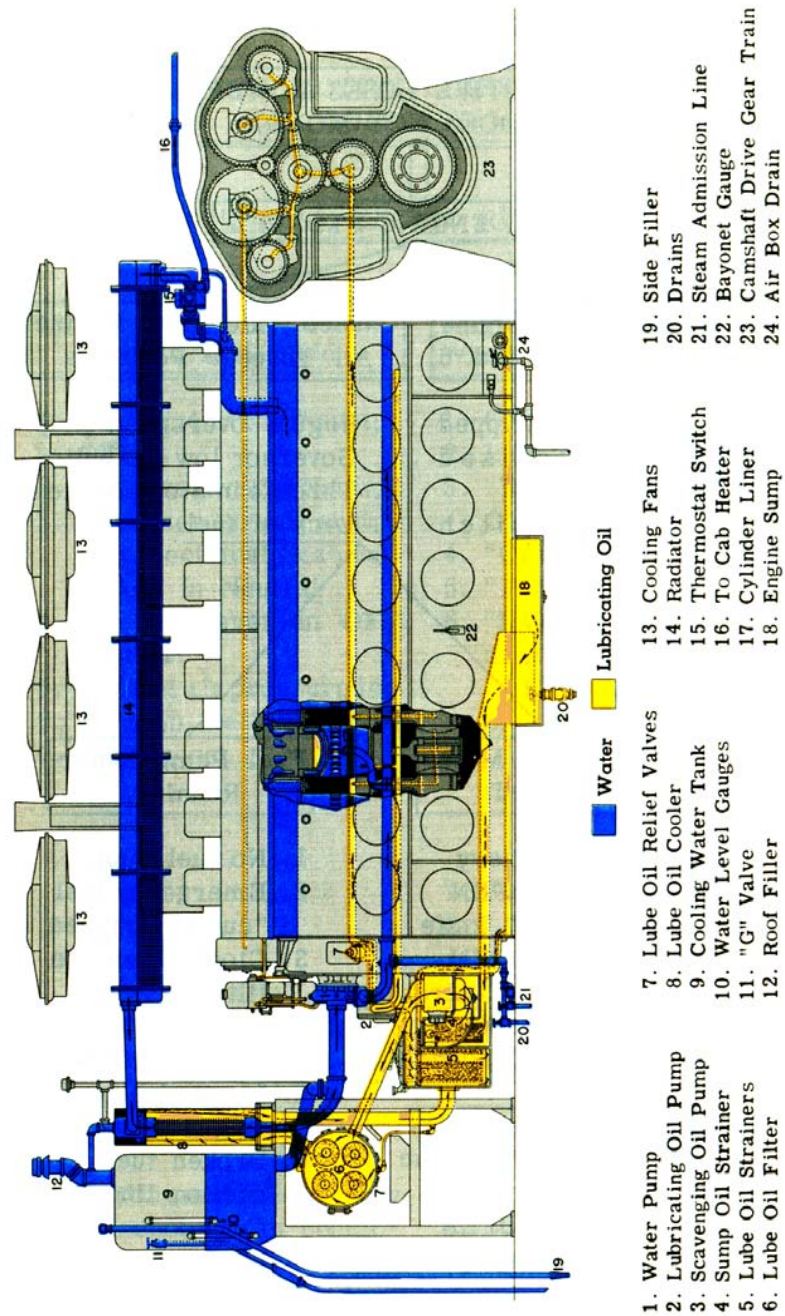

Fig. 4-1 - Schematic Of Cooling And Lube Oil Systems

A schematic flow diagram of the engine cooling system is shown in Fig. 4-1. Water is circulated through the cooling system by two centrifugal type pumps mounted on the front end of the engine. Water, drawn from the engine cooling water tank and oil cooler by the pumps, is forced through the engine and then through the radiator where it is cooled. After leaving the radiator, the water flows through the oil cooler and then to the suction side of the pumps where the cycle is repeated.

The radiator is made up of two banks; each bank consists of six radiator sections. Water leaving the engine and entering the radiator is divided between the right and left bank radiator sections, mounted above the engine.

Flow of cooling air through the finned radiator sections is controlled by shutters and four AC driven cooling fans. The operation of the fans and shutters is entirely automatic. When the fans are operating, air flows up through the radiator sections and is discharged from the roof of the carbody.

The four AC driven cooling fans are mounted in the roof above the radiator sections. The fans are numbered one to four, beginning with the #1 fan located nearest the cab end or front end of the locomotive. A thermostat switch, actuated by engine water temperature, controls the operation of the shutters and cooling fans through the temperature control relay, shutter air magnet valve, and the AC cooling fan

contactors, Fig. 4-2. A "Summer-Winter" selector switch located in the AC contactor panel, provides a method of altering the sequence of the fan and shutter operation. With the switch in the "Summer" position, the shutters will open before the first fan (#1) is energized. In the "Winter" position the shutters will open when the third fan (#3) is energized. As the outlet engine cooling water temperature rises, the sequence of fan and shutter operation is as follows:

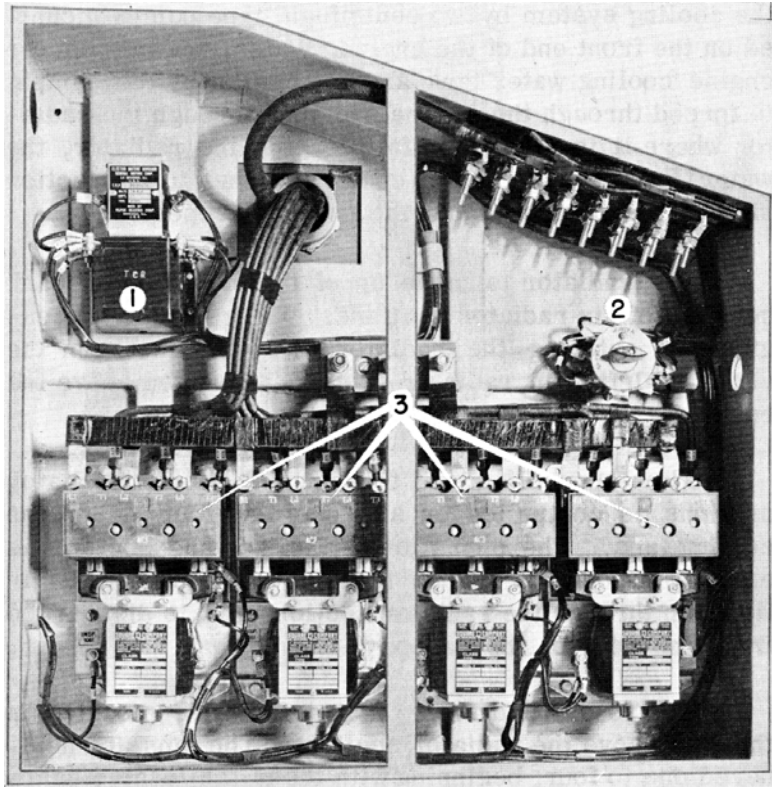

1. Temperature Control Relay 2. Summer-Winter Switch (SWS)
3. AC Cooling Fan Contactors

AC Contactor Panel
Fig. 4-2

With the "Summer-Winter" switch in "Summer" position:

- 163° F - Holding circuit for TCR is established
166° F - Temperature Control Relay (TCR) energized - shutters also open
169° F - #1 AC cooling fan starts
172° F - #2 AC cooling fan starts
175° F - #3 AC cooling fan starts
178° F - #4 AC cooling fan starts

With the "Summer-Winter" switch in "Winter" position:

- 163° F - Holding circuit for TCR is established
166° F - Temperature Control Relay (TCR) energized
169° F - #4 AC cooling fan starts
172° F - #2 AC cooling fan starts
175° F - #3 AC cooling fan starts - shutters also open
178° F - #1 AC cooling fan starts

As the engine cooling water temperature falls, any cooling fans that started will continue to run and the shutters, if open, will stay open until the outlet cooling water temperature drops to below 163° F. At this temperature the AC contactors will drop out (fans stop) and the shutters will close.

In the event of excessive cooling water temperature, the high temperature alarm switch will close, causing a red light (Hot Engine) to flash on in the unit affected, and the alarm bells to ring in all units.

400 Operating Water Level Operating water levels are stencilled on the water tank next to the water level sight gauge glasses to indicate minimum and maximum water levels with engine running and stopped. The engine should never be operated with the water below the low water level, Fig. 4-3. Progressive lowering of the water in the gauge glass indicates a water leak in the cooling system and should be reported.

401 Filling Cooling System The system is filled either through the filler pipe located on the roof of the locomotive above the water tank, or through the filler pipe at the rear of the unit on either side. To fill the system proceed as follows (steps 1 to 5 are necessary only when filling a dry or nearly dry engine):

1. Stop engine.
2. Open "G" valve.
3. Fill slowly until water runs out the "G" valve drain pipe.
4. Close "G" valve.
5. Start engine and run several minutes. This will eliminate any air pockets in the system.
6. Shut down engine and open "G" valve.
7. Add water until it runs out "G" valve drain pipe.
8. Close "G" valve.

If the cooling system of a hot engine has been 'drained, do not refill immediately with cold water. If this is done, the sudden change in temperature might crack or warp the cylinder liners and heads.

- CAUTION:**
1. Do not attempt to fill the cooling system through the drain pipe located underneath the locomotive.
 2. The system should not be filled above the maximum water level indicated on the water tank, Fig. 4-3.
 - a. To prevent freezing of radiators in winter, when engine is shut down.
 - b. To prevent loss of rust inhibitor when draining back to "G" valve level.

402 Draining Cooling System The entire cooling system can be drained through the drain valve on the floor in front of the engine, with the exception of the water pump on the right hand side of the engine. To drain the right hand water pump, open the drain on the bottom of the water pump housing.

403 Cab Heating A cab heater is located on each side of the cab. Hot water from the engine cooling water system passes through the heaters, and motor driven fans provide air circulation. The flow of water

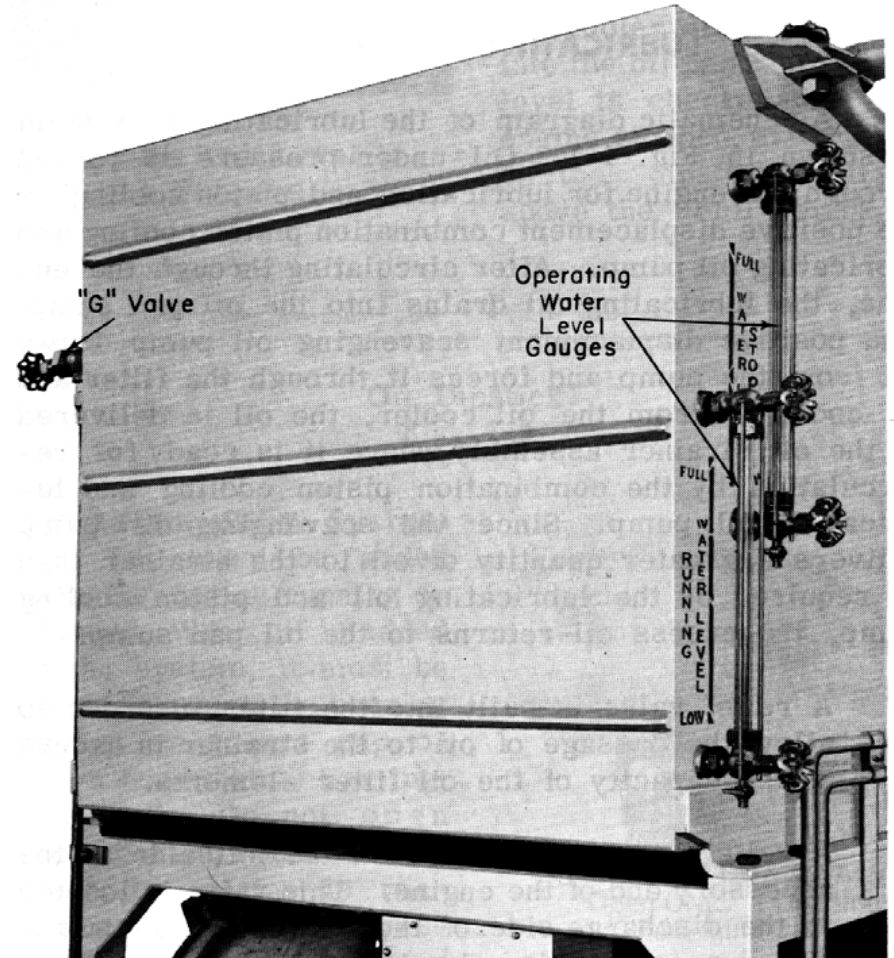

Cooling Water Tank
Fig. 4-3

to both heaters is controlled by a valve in the supply line, located over the left-hand cab to engine room steps. This valve must be kept wide open at all times in freezing weather. The output of each heater can be varied by use of the cab heater switches. The switches have four positions "OFF," 1, 2, 3, which provide three different motor speeds. If engine in the lead unit is shut down in freezing weather, steam may be admitted to the cab heaters on units equipped with steam generators.

LUBRICATING OIL SYSTEM

A schematic diagram of the lubricating oil system is shown in Fig. 4-1. Oil under pressure is forced through the engine for lubrication and piston cooling by the positive displacement combination piston cooling and lubricating oil pump. After circulating through the engine, the lubricating oil drains into the oil pan sump. The positive displacement scavenging oil pump draws oil from the sump and forces it through the filter and oil cooler. From the oil cooler, the oil is delivered to the oil strainer assembly where it is ready for recirculation by the combination piston cooling and lubricating oil pump. Since the scavenging oil pump delivers a greater quantity of oil to the strainer than is required by the lubricating oil and piston cooling pump, the excess oil returns to the oil pan sump.

A relief valve is built into the filter in order to allow the passage of oil to the strainer in excess of the capacity of the oil filter elements.

A relief valve is mounted on the left side of the accessory end of the engine. This valve is located in the discharge side of the lubricating oil pump. The purpose of this valve is to limit the maximum pressure of the lube oil entering the engine lube oil system to approximately 60 pounds.

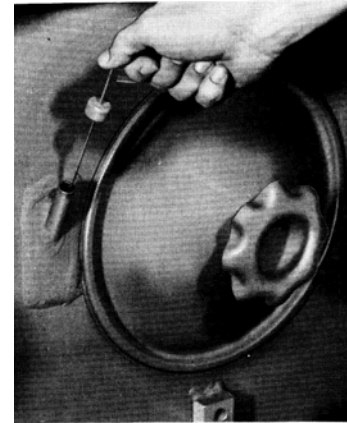

Lube Oil Level
Fig. 4-4

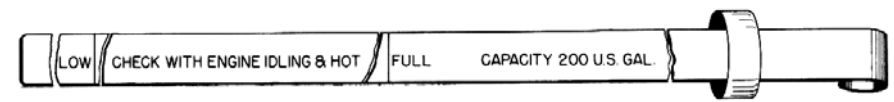

Oil Dipstick
Fig. 4-5

405 Adding Oil To System Oil may be added with the engine running or stopped. When oil is added to the system, it must be poured through the opening having the square cap on top of the strainer housing, Fig. 4-6. Do not open the adjacent round covers when the engine is running as hot oil under pressure will come out and possibly cause personal injury.

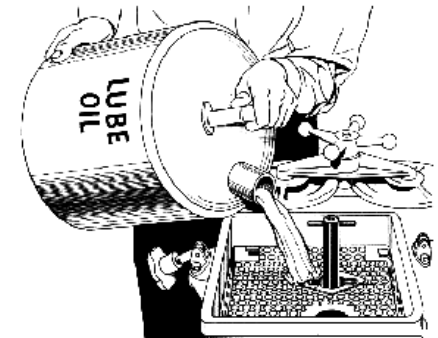

STRAINER DRAIN VALVE
Open ONLY If Draining
The Engine Oil Pan

Adding Oil To Engine
Fig. 4-6

406 Oil Pressure A lubricating oil pressure gauge is mounted on the engine control panel, Fig. 4-7. Oil pressure at 835 RPM is normally 40 to 50 pounds. It should not drop below 20 pounds. At idle the pressure should be at least 6 pounds. In the event of dangerously low oil pressure the engines will automatically be stopped by action of the governor low oil pressure button.

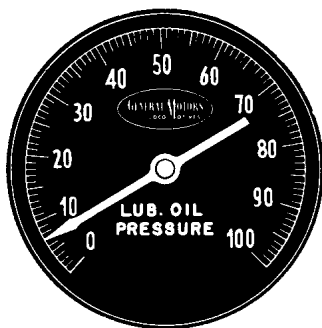

Lubricating Oil Pressure Gauge
Fig. 4-7

FUEL OIL SYSTEM

A schematic diagram of the fuel oil system is shown in Fig. 4-8. Fuel is drawn from the fuel tank through the suction filter by the motor driven gear type pump. From the pump the fuel is forced consecutively through the Ful-Flo filter and the sintered bronze filter. After passing through the double element sintered bronze filter, the fuel flows to the injectors. The excess fuel not used by the injectors returns to the fuel tank through the return fuel sight glass, mounted on the sintered bronze filter housing. An orifice restricts the flow of fuel into the glass and causes a slight back pressure of fuel on the injectors. By maintaining a slight back pressure on the injectors a positive supply of fuel for the injectors is assured.

The fuel pump delivers more fuel to the engine than is burned in the cylinders. The excess fuel circulated through the injectors is used for cooling and lubricating the fine working parts of the injectors.

A 15-pound relief valve is connected across the inlet and outlet fuel lines of the Ful-Flo filter. This relief valve by-passes fuel to the sintered bronze filter if the Ful-Flo filter elements become clogged.

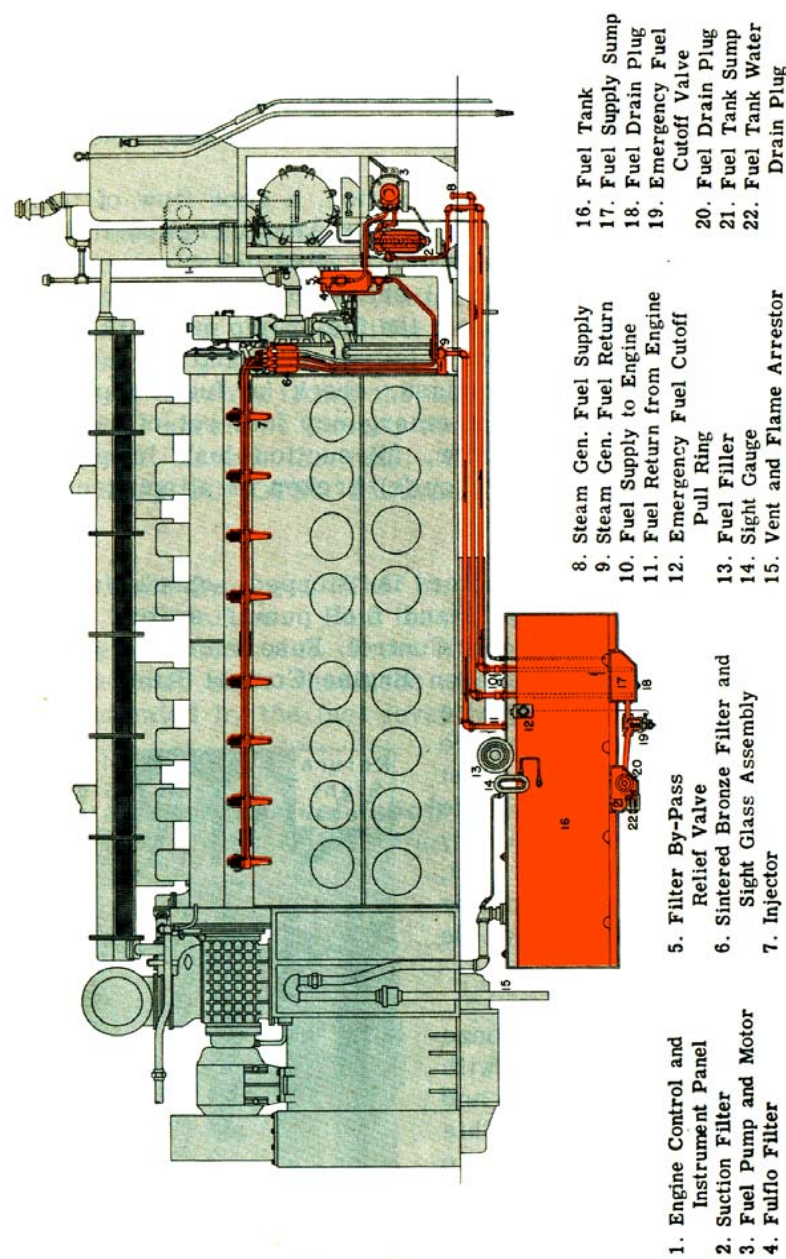

- 1. Engine Control and Instrument Panel
- 2. Suction Filter
- 3. Fuel Pump and Motor
- 4. Fulflo Filter
- 5. Filter By-Pass Relief Valve
- 6. Sintered Bronze Filter and Sight Glass Assembly
- 7. Injector
- 8. Steam Gen. Fuel Supply
- 9. Steam Gen. Fuel Return
- 10. Fuel Supply to Engine
- 11. Fuel Return from Engine
- 12. Emergency Fuel Cutoff Pull Ring
- 13. Fuel Filler
- 14. Sight Gauge
- 15. Vent and Flame Arrestor
- 16. Fuel Tank
- 17. Fuel Supply Sump
- 18. Fuel Drain Plug
- 19. Emergency Fuel Cutoff Valve
- 20. Fuel Drain Plug
- 21. Fuel Tank Sump
- 22. Fuel Tank Water Drain Plug

Schematic Of Fuel Oil System
Fig. 4-8

407 **Fuel Sight Glasses** Two sight glasses, Fig. 4-9, are mounted on the sintered bronze filter housing.

For proper engine operation, a good flow of fuel (clear and free of bubbles) should be indicated in the sight glass nearest the engine called the "fuel return sight glass." With no fuel showing in the fuel return sight glass, check to see if the fuel pump motor is running. If fuel pump motor is running, and no fuel is flowing in return sight glass, check (a) fuel supply in fuel tank, (b) position of emergency fuel cut-off valve, (c) clogged suction filter, (d) suction leak in piping between tank and pump, or (e) broken or slipping coupling at fuel pump.

If fuel pump motor is stopped, check (a) in "Lead" unit "Control" (and fuel pump) switch must be ON, and 30-ampere Control Fuse must be good, (b) "Fuel Pump" switch on Engine Control Panel must be ON, (c) 80-ampere

Control fuse and 10-ampere Fuel Pump Motor fuse must be good, (d) control knife switch and main battery switch should be closed, and (e) fuel pump motor cable connection may be loose.

The sintered bronze filter is also equipped with a 45-pound relief valve and sight glass, Fig. 4-9. This sight glass is referred to as the "45-pound sight glass" and is normally empty. When more than a trickle of

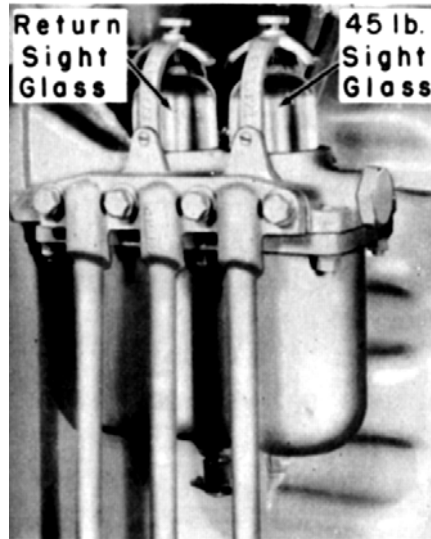

Sight Glasses
Fig. 4-9

fuel is seen in the 45-pound sight glass, it indicates that the relief valve is open. Fuel will pass through the 45-pound sight glass and relief valve to by-pass the engine and return to the fuel tank in case the sintered bronze filter becomes clogged.

408 **Filling Fuel Tanks** The fuel tank can be filled from either side of the locomotive. Direct reading sight level gauges located on each side of the fuel tank adjoining the fuel fillers indicate level of fuel oil starting at 4-1/2" from the top of the tank and should be observed while filling the tank to prevent overflowing. The fuel should be filtered through a reliable fuel filter before it enters the tank. **DO NOT HANDLE FUEL OIL NEAR AN OPEN FLAME.**

409 **Fuel Gauge** The basic fuel tank capacity is 1200 gallons. Full length sight level gauges are located on each side of the front end of the fuel tank. A graduated plate shows the amount of fuel in the tank as indicated by the fuel level in the glass.

410 **Emergency Fuel Cutoff Valve** An "Emergency Fuel Cutoff Valve," Fig. 4-10, is provided to cut off the fuel supply to the fuel

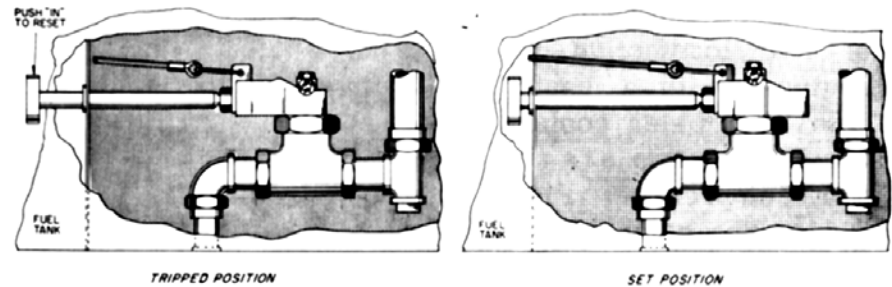

Emergency Fuel Cutoff Valve
Fig. 4-10

pump in the event of fire, or any emergency. It is located on the underside of the fuel tank on the left side of the locomotive. Adjacent to the fuel fill pipe on each side of the locomotive is a small box with a lift cover. Enclosed in this box is a pull ring attached to the end of the cable running to the fuel cutoff valve. A similar ring is located in the cab of the locomotive. The fuel cutoff valve can be tripped by pulling any one of these three rings. If tripped, the valve must be reset manually.

To reset the valve, "push in" on the rod extending from the valve compartment on the left side of the locomotive. Do not trip the emergency fuel cutoff valve unnecessarily as this may cause the engine to starve for fuel and is likely to cause damage to injectors.

AIR SYSTEM

Compressed air is not only used on a Diesel locomotive for operating the air brakes and sanders, but is also essential for proper operation of many other items. The reverser, power contactors, shutter operating cylinders, horn, bell, and windshield wipers are also air operated.

411 Air Compressor Each power plant of the locomotive is equipped with a basic type WBO water cooled 3-cylinder, two stage air compressor, Fig. 4-11. The compressor is driven through a flexible coupling from the armature shaft of the main generator.

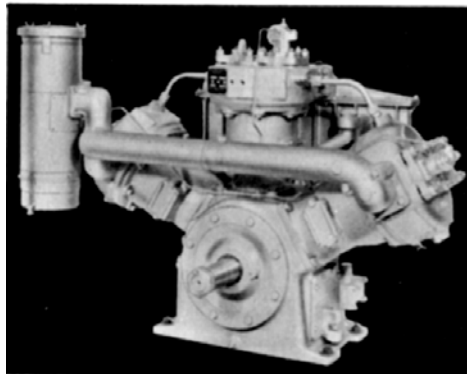

Air Compressor
Fig. 4-11

The compressor consists of two low pressure cylinders and one high pressure cylinder. The pistons of all three cylinders are driven by a common crankshaft. The two low pressure cylinders are set at an angle to the vertical high pressure cylinder. Air from the low pressure cylinder goes to an intercooler, or radiator, to be cooled before entering the high pressure cylinder. The intercooler is provided with a pressure gauge and relief valve. The gauge normally reads approximately 45 to 50 pounds when the compressor is loaded. The intercooler relief valve is set for 65 pounds. Any marked deviation of intercooler pressure from 45 to 50 pounds should be reported at the maintenance terminal.

It is recommended that the compressor intercooler (two drain valves are provided in the bottom header) and the main reservoirs be drained at the regular maintenance period, to prevent moisture and dirt from being carried into air brake and electrical control air systems.

412 Compressor Control Since the air compressor is directly connected to the engine and is in operation at all times when the engine is running (although not always pumping air), an unloader is provided in the heads of both high and low pressure cylinders which cuts out the compressing action when actuated by air pressure. The unloader accomplishes this by blocking open the suction, or intake, valves of the high and low pressure cylinders. When the air operating the unloader is cut off, the unloader releases the intake valves and the compressor resumes pumping. Air pressure from the main air reservoir actuates the unloader valves.

The loading and unloading of the compressor in each unit is controlled by an electro-pneumatic system, Fig. 4-12. The electrical arrangement is such that all compressors in the locomotive are synchronized to pump air into their respective main reservoirs when the main reservoir air pressure in any one unit drops to 130 pounds. When the air

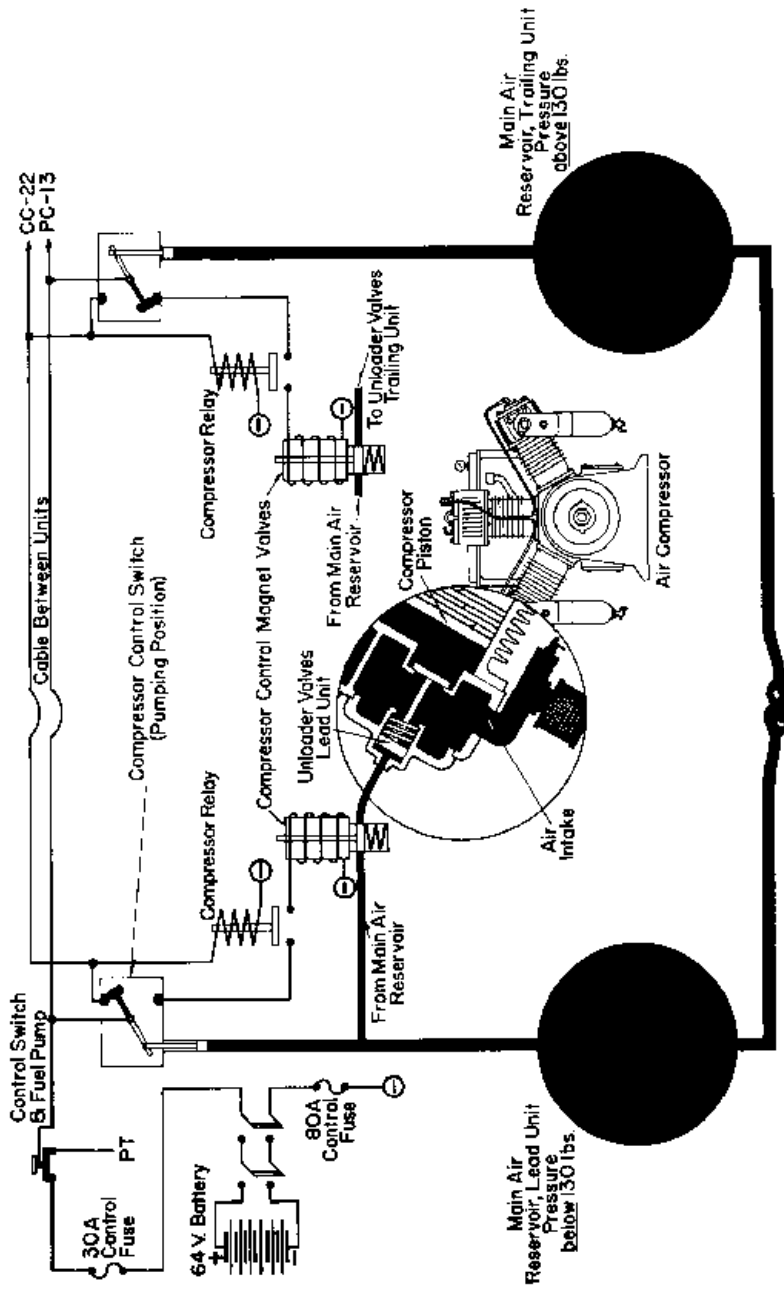

Electro-Pneumatic Governor Control System
Fig. 4-12

pressure in all main reservoirs reaches 140 pounds, the compressors will unload. Each unit is equipped with a compressor control switch (CCS) actuated by main reservoir pressure and a compressor relay (CR). A compressor control wire (CC) runs throughout the locomotive and connects the compressor relays in each unit in parallel.

The compressor control switch is located next to the alarm bell on the engine side of the electrical cabinet. This switch may be considered to be a single-pole double-throw switch that is thrown to the "loaded" position when the main reservoir pressure drops to 130 pounds, or to the "unloaded" position when the main reservoir pressure reaches 140 pounds. In the unloaded position the CCS causes the compressor control magnet valve to be energized, allowing air to pass through the valve to the compressor unloader pistons, stopping the compressing action. In the loaded position the CCS breaks the circuit to the compressor control magnet valve in that unit and causes current to flow through the CC wire energizing the CR relays in each unit. When the CR relay is energized its interlock breaks the circuit to the compressor control magnet valve regardless of the position of the CCS in that unit. Breaking the circuit to the compressor control magnet valve shuts off the supply of air to the compressor unloader pistons, and the compressor resumes pumping.

413 **Manual Unloader Valve** A three-way valve is provided in case it is desired to keep an air compressor unloaded, Fig. 4-13, irrespective of the compressor control system. Normally the valve handle is in a horizontal position; turning the handle to a vertical position causes the compressor to remain unloaded. The other valve in the line leading from the main reservoir will shut off the air supply to the unloader pistons, allowing the compressor to load continuously.

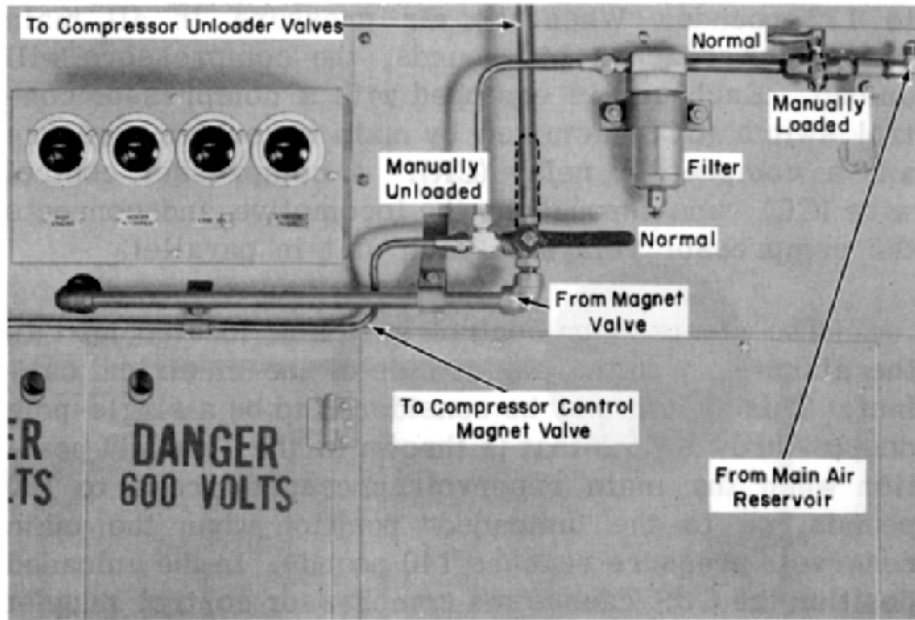

Manual Unloader Valve
Fig. 4-13

414 Draining Of Air System The air system should be drained periodically to prevent moisture from being carried into the air brake and electrical control air systems. The frequency of draining will depend on local conditions and can be determined by practice. It is recommended that draining be done at the time of each crew change, until a definite schedule can be determined by the individual railroad.

- 415 -

SECTION 5

ELECTRICAL

500 Basic Electrical Systems In full throttle, the rated horsepower of the engine is delivered to the direct coupled main generator. At the main generator the power of the engine is transformed into electrical power. The electrical power is then conducted to the four traction motors, two motors being located in each truck (each motor being geared to an axle).

The locomotive is designed so that within the current and voltage limits of the main generator, the power (KW) delivered to the traction motors at full throttle is the same, regardless of the locomotive's speed.

The electrical system of the locomotive can be thought of as being divided into three separate systems:

1. High voltage system (includes dynamic braking system - if used).
2. Low voltage system.
3. Alternating current system.

The high voltage system is directly concerned with moving the locomotive; or in retarding the locomotive in case dynamic brakes are supplied and are in use. The main components of the high voltage system are the main generator, traction motors, transition relays, shunt field contactor, motor shunting contactors, reverser drum, wheel slip relays, ground relay, series and parallel power contactors. On a locomotive equipped with dynamic brakes, the brake transfer switch, brake grid blower motors, and brake grids may also be considered to be in the high voltage system.

The low voltage system contains the control circuits which control the flow of power in the high voltage system, and those auxiliary circuits conducting power to the locomotive lights, heater fans, fuel pump

- 500 -

and the main generator battery field. A 64 volt battery, in the low voltage system, is the source from which power is taken to start the Diesel engine. Once the engine is started, the auxiliary generator takes over the job of supplying power to the low voltage system.

The alternating current system includes an alternating current generator (called an alternator), four engine cooling fan motors, and four traction motor blower motors. The alternating current system provides a means of driving accessories, without the use of belt drives, at speeds which vary according to the speed of the engine.

501 Main Generator The voltage of the main generator, Fig. 5-1, is nominally 600 volts but this varies with engine speed and the conditions of operation of the locomotive. The main generator contains six field windings: starting, battery, shunt, differential, compensating, and commutating. The starting field is used only when the main generator is used as a starting motor to rotate the engine. With regard to locomotive

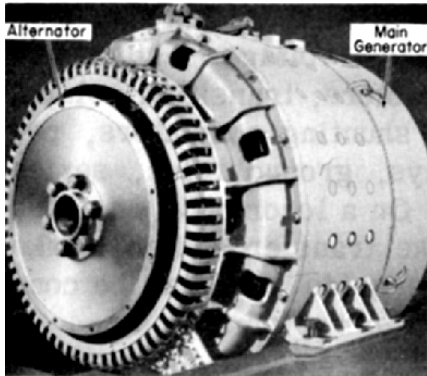

Main Generator
Fig. 5-1

operation, the shunt and battery fields are the more important; these two fields provide the main excitation of the generator.

The battery field is a low voltage, externally excited field. The current flowing through the battery field, which initially excites the main generator, is varied by the load regulator. By varying the strength of the battery field, the power output of the main generator is largely controlled. The battery field

battery field contactor BF opens or closes the circuit to the battery field. The main generator is self-excited by the shunt field. The shunt field is a high voltage field whose excitation varies with the voltage of the main generator. A shunt field contactor SF opens or closes the circuit to the shunt field. Interlocks are built into the shunt field contactor so that this contactor must close before the battery field contactor can close.

The differential, compensating and commutating fields are permanently connected and are a matter of engineering design providing desired generator characteristics and proper commutation.

502 Traction Motors The traction motors, Fig-5-2, are direct current, series wound motors geared to the driving axles. The motors are reversed by changing the direction of current flow in the field windings, the direction of current flow in the armature always being the same. A reverser drum operated by electro-pneumatic control reverses the current flow in the traction motor field windings.

The traction motors are cooled by alternating current driven blowers, one for each motor. The traction motor blowers are mounted on the floor of the engineroom and blow air through flexible ducts to the traction motors. The speed of the blowers varies with the speed of the engine; this is due to the engine speed varying the frequency of the alternator.

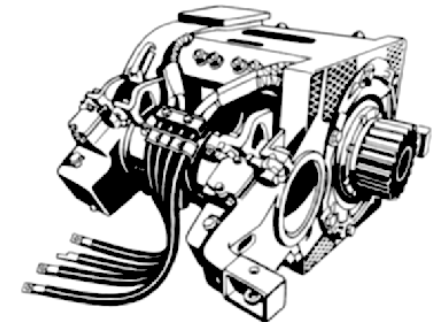

Traction Motors
Fig. 5-2

The maximum permissible top speed of the locomotive is limited by

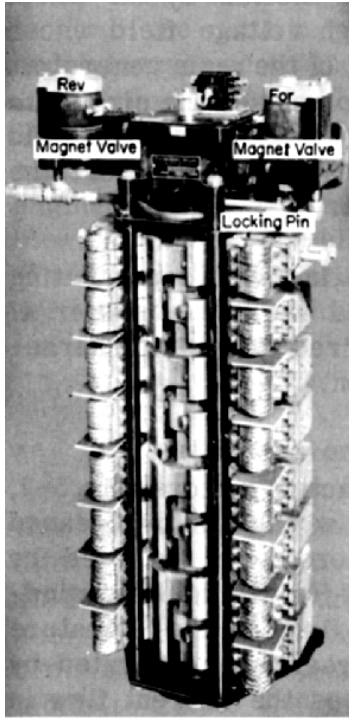

**Reverser Switch
Locked In Neutral
Fig. 5-3**

electric locomotives so that full power may be obtained from the main generator within the range of its current and voltage limits. To look at it another way, transition is a method of adjusting the traction motor "back pressure" (counter -e.m.f.) bucking the input of power from the main generator so that this back pressure will not become too high at higher speeds nor too low at lower speeds.

- 53 -

the safe RPM of the traction motor armature; thus a high speed gear ratio is required for high speed train operation. A low speed gear ratio is needed to start and use full horsepower with low speed tonnage trains without overheating and damaging the electrical equipment.

503 Reverser Movement of the reverse lever to the forward or reverse position energizes the respective FOR or REV magnet valves on the reverser, Fig. 5-3, located in the electrical cabinet. When either of the magnet valves is energized it allows control air to pass through the valve, moving the reverser to the desired direction (with four long segments showing on reverser drum, the reverser is in forward; eight short segments can be seen when in reverse position).

504 Transition This term is applied to the changing of traction motor electrical connections on all Diesel-

Standing still the traction motors have practically no "back pressure," or resistance to the input of current from the main generator. However, as the locomotive speed increases after starting in series-parallel (transition 1), Fig. 5-4A, the "back pressure" of the traction motors builds up and causes the main generator "pressure" (voltage) to increase so that it can continue forcing current into the motors. Although the main generator can vary its voltage over a wide range, there is a practical operating limit to its ability to increase its voltage. If this practical voltage limit were exceeded, the power output of the main generator and correspondingly, the engine, would drop off. To prevent this loss of power, a change is made in the electrical circuit just before the drop-off begins. The first change, Fig. 5-4B, from transition 1 to 2 (series-parallel-shunt) connects a by-pass (shunt) circuit around each of the traction motor fields. Shunting the traction motor fields effects a reduction in the "back pressure" of the traction motors, which in turn allows the voltage in the main generator to reduce itself (with a constant KW generator, as the voltage goes down the amperage goes up, and vice versa). Thus, by shifting to transition more current can pass

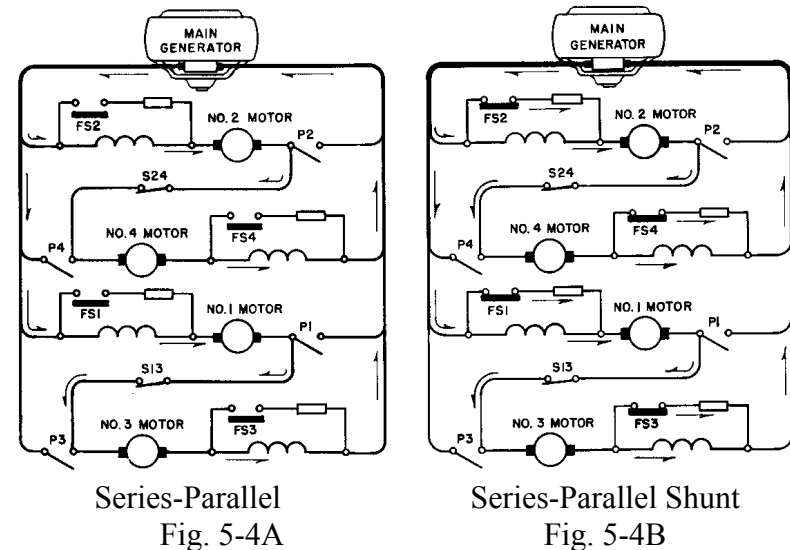

- 504 -

through the traction motor armatures to maintain the full power output of the locomotive.

As the locomotive speed increases there is again a tendency for the power to drop off. This time, when the main generator reaches sufficient voltage, a complete change in the electrical circuit is necessary to once again reduce the "back pressure" of the traction motors. When this change, from transition 2 to 3 (parallel), Fig. 5-5A, is completed the main generator continues the full application of power until a still higher locomotive speed is reached. At this time, when the voltage increases, the motor shunting contactors are again closed (reducing the traction motor "back pressure") effecting transition from 3 to 4 (parallel-shunt), Fig. 5-5B. With decreasing speeds, as caused by grades, a reverse sequence of transition takes place to prevent exceeding the current limitations of the main generator.

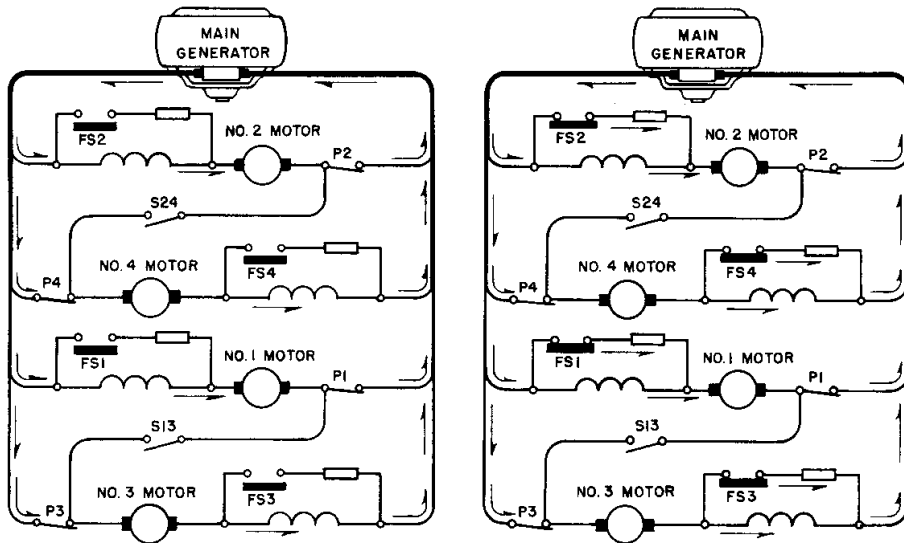

Parallel
Fig. 5-5A

Parallel Shunt
Fig. 5-5B

505 Transition Control Circuit Two relays (FSR and PTR), Fig. 5-6, actuate the changing of traction motor connections in the forward and backward transition.

E-I type transition is an automatic transition which, as the name implies depends primarily upon generator voltage and current (voltage and current ratio) for operation. Forward and backward transition are initiated by two (2) through cable type relays (FSR and PTR) which operate on generator voltage and are biased by generator current. This transition differs from the earlier transition which was dependent primarily on generator voltage to initiate all forward transition steps and backward transition from shunting positions. Generator amperage was used for initiating backward transition from parallel.

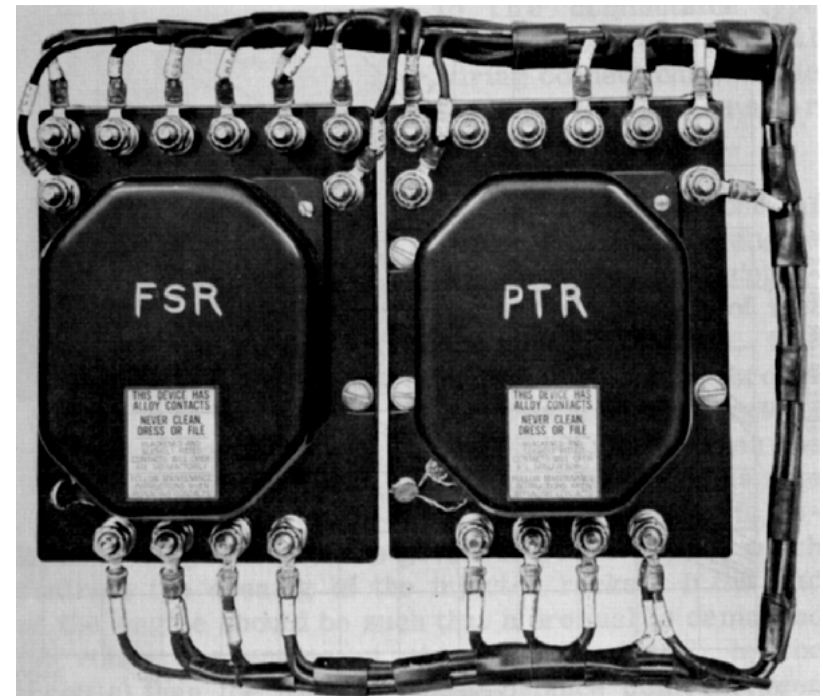

Transition Relays Fig. 5-6

Transition is used to initiate a change in motor connections so that full power may be obtained from the generator within its current and voltage limits. In addition to satisfying the above condition, E -I transition permits transition to take place at intermediate throttle positions assuming that the locomotive is traveling at or above transition speed.

Transition can take place on these locomotives equipped with E-I type transition, assuming locomotive is at transition speed at throttle position 2 and above, resulting in a fairly constant KW output throughout the speed range of the locomotive for any given throttle position. At low generator current, the FSR and PTR relays pick up at a relatively low generator voltage and as the generator current is increased, the relays pick up at a higher generator voltage, Fig. 5-7. In

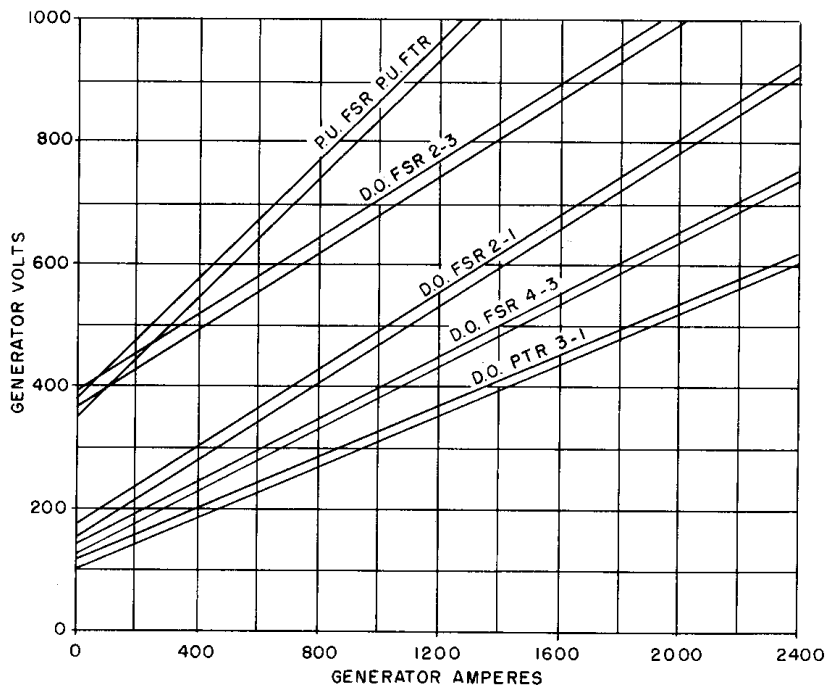

Transition Relay Settings

Fig. 5-7

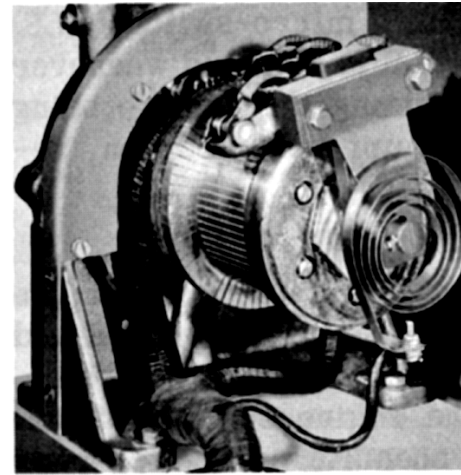

Load Regulator
Fig. 5-8

regulator pilot valve located in the engine governor.

The load regulator has two components: (1) the pilot valve in the engine governor, and (2) a self-contained unit consisting of a hydraulic vane type motor attached to the commutator type rheostat. The only external wiring connections are two leads to the generator battery field circuit.

For the purpose of load regulation, the engine horsepower output is determined by the rate of fuel consumption. Thus, for each position of the throttle there is a definite rate of fuel consumption when the engine is loaded. The rate of fuel consumption is related to the position of the governor power piston, which controls the opening of the injector racks. If the load on the engine should be such that more fuel is demanded (to rotate the engine at the RPM "ordered" by the throttle) than the predetermined balance point (between load and fuel consumption), the load regulator pilot valve will cause the load regulator to reduce the engine load the required amount by reducing the battery field strength.

other words, the FSR and PTR relays operate at a fixed current voltage ratio at the various throttle positions and KW levels.

506 Load Regulator

The load regulator, Fig. 5-8, is an automatically operated rheostat connected in series with the battery field of the main generator. Engine oil pressure is used to force the vane motor of the rheostat brush arm to vary its position. Oil pressure is impressed on either side of the vane, as directed by a load

If the engine requires less fuel than the predetermined setting, the load regulator increases the load on the engine by increasing the battery field excitation of the main generator. In this manner, battery voltage, temperature changes in the generator windings, or locomotive speeds do not cause overloading or underloading of the engine and a constant power output is maintained for each throttle setting.

An overriding solenoid, ORS, in the governor, is energized whenever the battery field contactor is open; such as whenever the throttle is in idle, during transition from 3 to 2 or 2 to 3, or during wheel slip action. The energizing of this solenoid causes the load regulator to move into or toward the minimum field position, depending upon the length of time that the ORS is energized, unloading the engine. Another switch that can energize the ORS is the overload micro-switch (OLS) located in the governor. The OLS is actuated whenever the engine is overloaded; energizing the ORS to bring the load regulator toward minimum field position, reducing the load on the engine.

507 Engine Speed Control The throttle lever, in the controller, has ten positions: STOP, IDLE and RUNNING SPEEDS 1 THROUGH 8. Each throttle step, from 2 through 8, increases the engine speed 80 RPM. The throttle lever operates a phenolic cam which controls enclosed roller switches to distribute current from a "hot wire" to one or more other wires, depending on the position of the throttle.

The governor is designed so that the energizing of various combinations of four governor solenoids (AV, BV, CV, and DV) causes the engine to respond to the "orders" of the throttle. The "ENGINE SPEED CHART" shows the various combinations of solenoids that are energized to obtain the desired engine speeds for the various throttle positions. The Engine Speed Control schematic diagram, Fig. 5-9, shows the method of energizing the various governor solenoids for the various positions of the throttle.

ENGINE SPEED CHART

Throttle Position	Governor Solenoids Energized				Engine Speed RPM
	A	B	C	D	
STOP				*	0
IDLE					275
1					275
2	*				355
3			*		435
4	*		*		515
5		*	*	*	595
6	*	*	*	*	675
7		*	*		755
8	*	*	*		835

Effect of Solenoids on Engine RPM

	+80	+320	+160	-160 (or stop)
--	-----	------	------	----------------

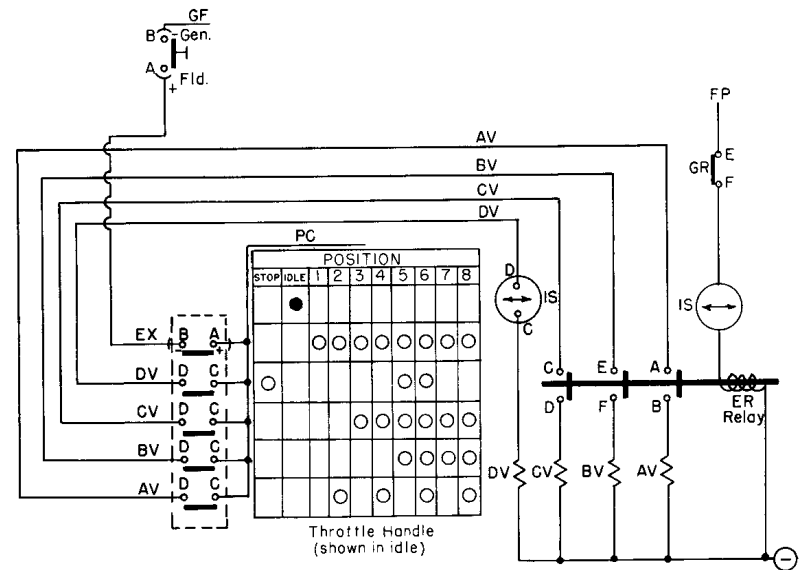

Engine Speed Control
Fig. 5-9

508 ER Relay The ER relay controls the current supply to the A, B, and C governor control solenoids. The ER relay has no control of the D governor control solenoid, which is used to shut the engine down. The D solenoid is energized in throttle positions STOP, Run 5 and Run 6. De-energizing the ER relay with the throttle in Run 5 or 6, will cause the engine to shut down. De-energizing the ER relay in any other throttle position will automatically reduce the speed of the engine to IDLE.

To control the engine speed in any unit, the ER relay in that unit must be energized. The ER relay has three normally open interlocks which will close, when the relay is energized, to connect the control circuits to the A, B, and C governor control solenoids, Fig. 5-9.

The ER relay in each unit is energized by current received from the FP wire that runs throughout the locomotive. For current to flow through the FP wire to the ER relay; the main battery and control knife switches must be closed, the "Engine Run" switch at the engineman's control panel must be ON, the ground relay must be set, the PC switch must be closed (PC light out), the isolation switch must be in RUN and the NVR relay must be energized (engine must be running).

509 Battery Field Contactor And Fuse When the throttle is moved to Run 1 this contactor, Fig. 5-10, closes and connects low voltage excitation to the main generator battery field. The battery

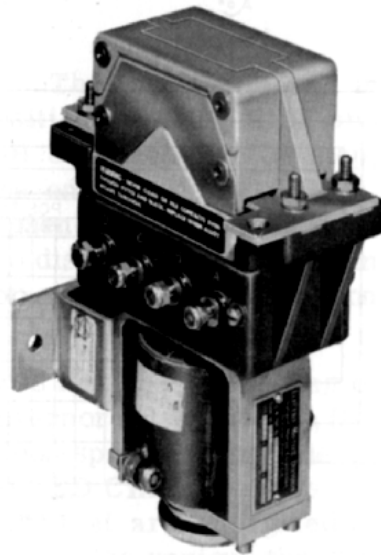

Battery Field Contactor
Fig. 5-10

field (BF) contactor remains closed as long as power is being applied, but will open during transition 2 to 3 and 3 to 2 and wheel slip action to reduce main generator output. A rectifier and discharge resistor are used to dissipate the high voltage induced in the battery field when the BF contactor is opened.

An 80 ampere battery field fuse, located in the low voltage panel protects the battery field circuit. If the fuse is blown, the unit will not develop normal power.

510 Wheel Slip Control The wheel slip control system goes into operation the moment that the slipping of a pair of wheels is detected while under power. Four wheel slip control relays, WS13, WS24, WSS, and WCR, located in the electrical cabinet, are of the through able type, Fig. 5-11.

The WS13-24 relays are operated by two sources: (1) by a flow of current through the relay coil with the traction motors connected in series-parallel or series-parallel shunt. Current will flow through the relay coil, when an unbalance in the bridge circuit between two 2000 ohm resistors and two traction motors, which the relay coil bridges, occurs as a result of a "slipping" motor. (2) By a current differential between the cables that pass through the relay frame with the traction motors connected in parallel or parallel shunt. These cables are so arranged that the normal current flow through them is of equal magnitude and in

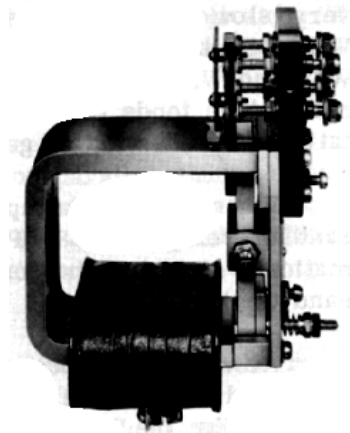

Wheel Slip Relay
Fig. 5-11

opposite directions. Thus, the magnetic field established by the current flow in one cable is nullified by the magnetic field established by the current flow in the second cable. When an unbalance in the current flows occurs as a result of a "slipping" motor, the resultant magnetic field established actuates the WS relay.

The WCR (wheel creep relay) and WSS (wheel slip series) are operated only by a current differential between the cables that pass through the relay frame, with the traction motors connected in series - parallel or series-parallel-shunt.

Automatic sanding in power occurs through the action of the WCR relay. The WCR is used to detect very slow creeping type slips. The function of the WCR, having a slightly lower pickup value than the WSS and WSR, is to apply sand automatically to the rails which tends to prevent a wheel slippage necessitating the reduction of generator field excitation.

When WCR picks up, it energizes the time delay sanding relay (TDS). "Picking up" of the TDS automatically actuates the forward sanding valve, applying sand to the rail.

At very slow speeds, if the wheel slip cannot be corrected through the action of the WCR applying sand to the rails, the WSS picks up to reduce main generator excitation. When the WSS picks up, the wheel slip light will flash ON and the battery field contactor (BF) will open. Opening the battery field contactor, "cuts out" the main generator battery field excitation and causes the overriding solenoid (ORS) to move the load regulator toward the minimum field position. This action will generally correct the wheel slip, and it should not be necessary for the enginemen to reduce the throttle. The function of the WSS relay is to recognize slow speed wheel slips and effect a slip correction with a minimum loss of tractive effort.

If further reduction of main generator excitation is necessary to correct the wheel slip, the WS relay, actuated by a current flow through the relay coil, picks up and opens both the battery and shunt field contactors, reducing the excitation of the main generator to a point where slipping stops. The time delay sanding valve (TDS) is energized, automatically applying sand to the rails. When the shunt field contactor opens, an additional resistance is added into the shunt field circuit resulting in a further but controlled unloading of the main generator. Opening the battery field contactor energizes the ORS, and the load regulator moves toward the minimum field position. Thus, as soon as the slipping stops, the WS relay will drop out, and power will automatically be reapplied at a lower level than that at which the slipping was initiated. The application of power will then gradually return to that designated by the position of the throttle.

To correct high speed wheel slips with the traction motors connected in parallel or parallel-shunt, either of the WS relays actuated by a current differential between traction motors 1 and 3 (WS13) or 2 and 4 (WS24) will pick up to reduce main generator excitation to a point where slipping stops.

Since sand is automatically applied to the rails during a wheel slip detection, it should be unnecessary for the enginemen to operate the manual sanders. If continuous wheel slipping on sand occurs, the throttle should be reduced.

511 Main Battery Switch This switch is located on the distribution panel and connects the 32 cell, 64 volt, 426 ampere-hour capacity (8 hour rating) battery to the low voltage circuits. An external charging receptacle is located on the left side of the locomotive. To start the Diesel engine and during normal locomotive operation, the main battery switch should be closed.

512 Battery Ammeter The battery ammeter is visible through an opening on the front side of the electrical cabinet. This ammeter, Fig. 5-12, only shows whether the battery is charging or discharging. Normally the meter will indicate zero or a slight charge. If a continual discharge is shown, the auxiliary generator output should be checked, or the battery may run down.

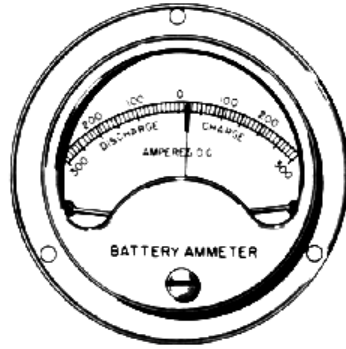

**Battery Ammeter
Fig. 5-12**

513 Reverse Current Relay This relay, Fig. 5-13, located on the low voltage panel, controls the opening and closing of the battery charging contactor (BC). The RCR causes the BC contactor to open when the auxiliary generator voltage drops below the battery voltage. This prevents a reverse flow of current from the battery attempting to "motor" auxiliary generator.



**RCR — Micropositioner
Fig. 5-13**

514 Battery Charging Contactor This contactor is an electrically operated switch connecting the auxiliary generator output to the low voltage system. The reverse current relay controls the operation of the battery charging contactor.

515 Ground Relay The ground relay, Fig. 5-14, located in the electrical cabinet, is an electrical protective device connected to the high voltage system. The function of this relay is to unload the main generator automatically in case of a ground in the high voltage system (a ground can be defined as a current passing through the frame, or carbody, of the locomotive).

If a ground in the high voltage system should occur, the ground relay will trip. When tripped, the ground relay opens the shunt and battery field contactors, unloading the main generator. The ground relay must be reset before the unit can again deliver power. The relay is reset by pressing in the remote reset button. If the relay repeatedly trips when power is applied, the power plant MUST be isolated.

CAUTION: Isolate unit before resetting the ground relay.

With ground relay tripped, the speed of the engine will be automatically reduced to Idle. If the ground relay tripped while the throttle was in the 5th or 6th notch, the engine would stop.

Although a high voltage ground will normally be the only reason for the ground relay tripping, a low voltage ground can trip the relay when the engine is started; since at that time the high and low voltage systems are temporarily connected. Ground relay action is not



**Ground Relay
Fig. 5-14**

necessarily an indication of serious trouble but should be reported to the maintenance authorities.

The ground relay knife switch, when open, eliminates the protection of the ground relay. This switch **MUST NOT BE OPENED** in normal operation unless definite instructions are issued by an official of the railroad.

516 Voltage Regulator

The voltage regulator, Fig. 5-15, is located in the electrical cabinet. The voltage regulator performs the function of seeing that the output voltage of the auxiliary generator remains at approximately 74 volts whenever engine is running.

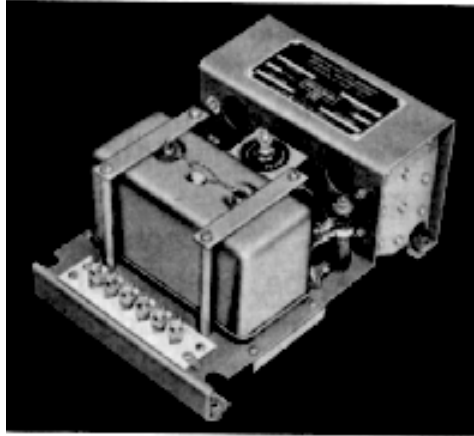

Voltage Regulator
Fig. 5-15

517 Auxiliary Generator Fuse (Battery Charging)

This 150 ampere fuse, Fig. 5-16, located on the low voltage panel, protects the auxiliary generator against any possible overload. A blown auxiliary generator output fuse will cut off the auxiliary generator from the low voltage system and the alternating current system. The battery ammeter will indicate a discharge when this fuse is blown, the alarm bell will ring, and the "Alternator Failure" light (blue) will flash on in the unit affected.

518 Auxiliary Generator Field Fuse This 30ampere fuse protects the auxiliary generator field windings against excessive current, Fig. 5-16. Blowing of this fuse will prevent the auxiliary generator from

supplying current to the low voltage system and alternating current system. With this fuse blown, the battery ammeter will indicate a discharge, the alarm bell will ring, and the "Alternator Failure" light (blue) will flash on in the unit affected.

519 Alternator Field Fuse This 35-ampere fuse, located on the low voltage panel, protects the alternator field, Fig. 5-16. If blown, the alarm bell will ring and the "Alternator Failure" light (blue) will flash on in the unit affected.

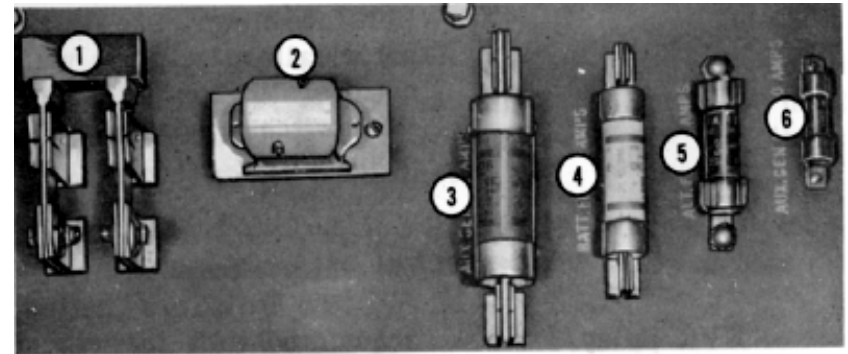

- | | |
|----------------------------------|---------------------------------------|
| 1. Auxiliary Generator Switch | 4. 80A Battery Field Fuse |
| 2. RCR – Micropositioner | 5. 35A Alternator Field Fuse |
| 3. 150A Auxiliary Generator Fuse | 6. 30A Auxiliary Generator Field Fuse |

Low Voltage Panel
Fig. 5-16

520 No AC Voltage Relay (NVR) As the traction motors are cooled by AC driven blowers, failure of the alternator could result in damage to the traction motors unless the application of power was stopped. Thus, in case of an alternator failure, the NVR, Fig. 5-17, located on the low voltage panel, drops out and causes the alarm bell to ring in all units. The "Alternator Failure" light (blue) will flash on, and the engine speed will be reduced to idle in the unit affected (if the throttle was in the 5th or 6th notch the engine would stop).

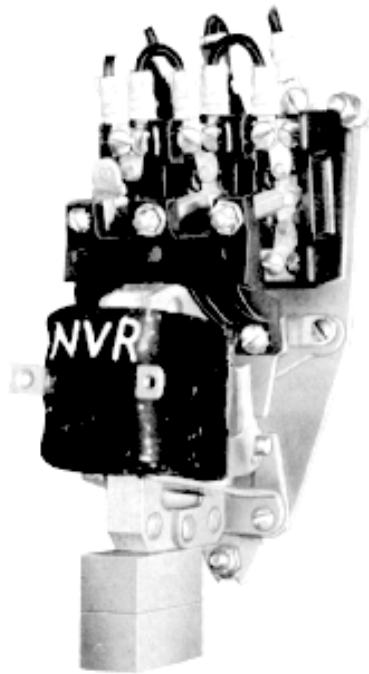

NVR Relay
Fig. 5-17

The "NVR" dropping out can be caused by (1) engine stopped, (2) auxiliary generator fuse (battery charging) blown, (3) auxiliary generator field fuse blown, or (4) alternator field fuse blown. The alternator failure alarm will not operate when the isolation switch is in the START position.

521 **Electrical Circuits** To become better acquainted with the electrical system of the F9 type locomotive, a step by step description (through the use of schematic diagrams) of the more important electrical circuits involved with the operation of these locomotives will be given.

The Electrical Symbols and Legend used on these diagrams will be found at the end of this section. One thing that might bear mentioning before starting on the circuits, is interlocks and their identification.

A relay, or contactor, as used on a Diesel locomotive, consists of an operating coil, a set of main contacts and/or several auxiliary contacts called interlocks. The interlocks can be normally open or closed with the operating coil de-energized (dropped out). Energizing (picking up) the coil will change the normal position of the relay interlocks. See Fig. 5-18.

Thus, an interlock shown on the wiring diagram in a closed position will open when its respective operating coil becomes energized (Example: P1_{ab} interlock normally closed will open when the P1 contactor operating coil is energized.)

When the coil is de-energized (drops out) the interlock returns to its normally closed position. Similarly, an interlock shown on the wiring diagram in an open position will close when its respective operating coil becomes energized (picks up). When the coil is de-energized (drops out) the interlock will return to its normally open position.

The circuits traced will be those on the Electro-Motive Model F9 locomotive. Similar circuits are used on other General Motors locomotives thus all others will be very much the same.

On the diagrams it will be noted that the bottom wire is a common wire leading to the negative side (-) of the battery. Many devices

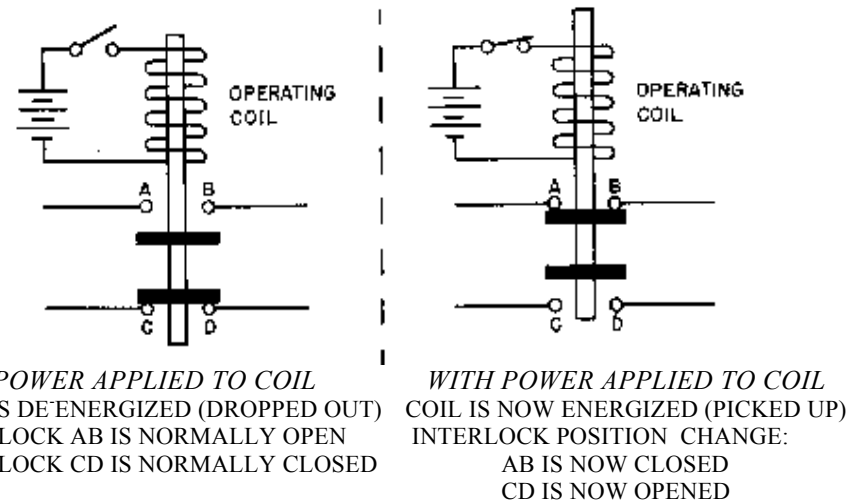

Operation Of Interlocks

Fig. 5-18

are connected to this wire and hence it will not be necessary to trace all of the circuits back to the source.

Fuel Pump Circuit (Fig. 5-19)

After all preliminary steps have been followed preparatory to starting the locomotive, the first circuit that is energized is that of the fuel pump.

Starting at the positive (+) side of the battery continue through the main battery knife switch, ammeter shunt, the control knife switch to the 30-ampere control fuse. Going through the fuse and through the "Control" (and fuel pump) switch on the engineman's control stand in the cab, continue on the PC wire which runs throughout the locomotive, to the right to the first intersection. Follow this PC wire down to the throttle control stand where a roller type switch is energized when the throttle is in IDLE position. From here go through the PCS contacts to the PCR coil. Note that the PCR interlock CD above will now close establishing a holding circuit so PCR can stay energized after throttle is opened. From the PCR coil the circuit is completed back to the negative side of the battery through the 80-ampere control fuse, control knife switch and main battery switch.

Starting back at the "Control" (and fuel pump) switch again follow the PC wire. This time go to the right as far as possible. The PC wire then goes down to the FPC coil which closes the interlocks AB and CD of the FPC in the Fuel Pump Motor Circuit. Now coming from the positive side of the control switch go down through a 10-ampere fuel pump motor fuse, the AB and CD of the FPC, the fuel pump toggle switch on the Engine Control Panel directly to the fuel pump motor. The fuel pump motor starts and fuel oil is now being fed through the system.

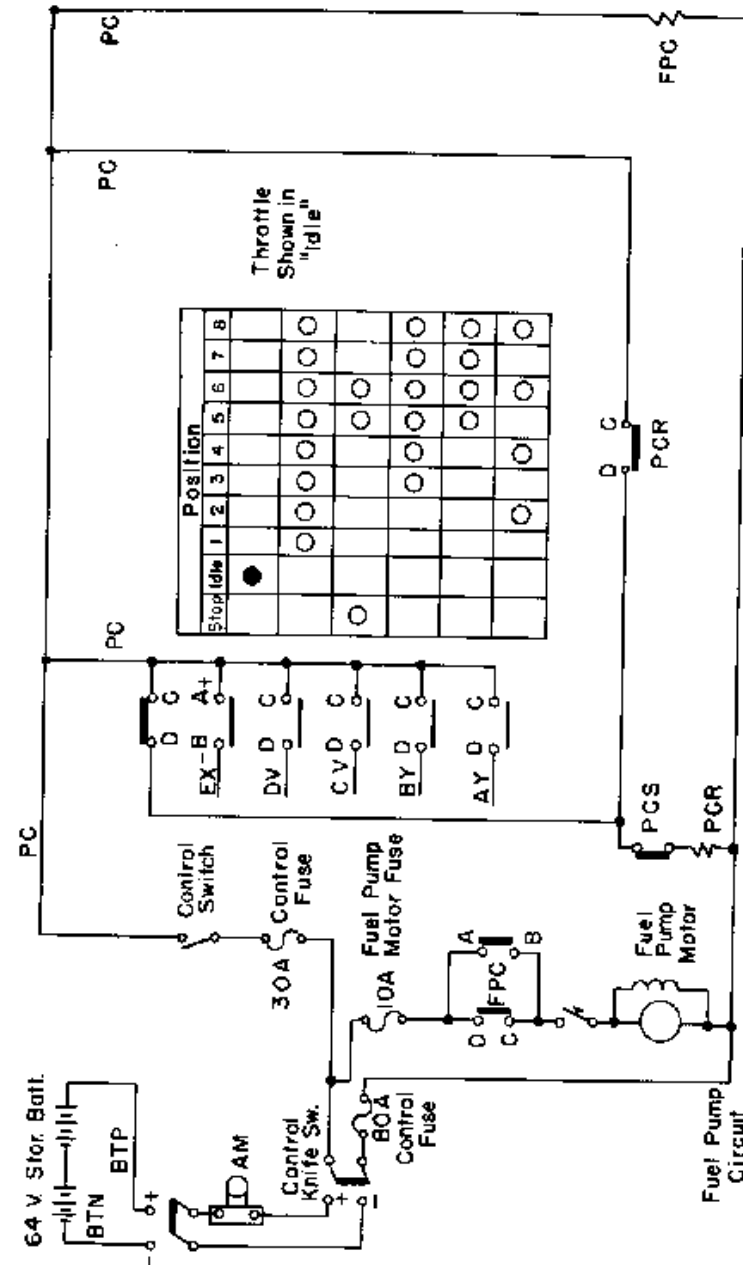

Fuel Pump Circuit
Fig. 5-19

Engine Starting Circuit (Fig. 5-20)

The next circuit in the sequence will be to start the engine through the starting circuit.

From the PC wire of the control circuit previously established follow the PC wire down through the AB finger of the isolation switch which will be closed when the isolation switch is in START position. From there go through the START push button to the starting contactor coil (GS). This coil now closes the GS contactor in the high voltage system. Battery current now flows from a positive connection just below the main battery switch, through a 400-ampere starting fuse, the GS contactors positive terminals, the main generator armature, the differential, compensating, commutating and starting fields of the main generator, the GS contactors negative terminals back to the negative side of the battery. The main generator now acting as a motor cranks and starts the Diesel engine. The START button can now be released which breaks the circuit to the GS coil which allows the GS contacts to open disconnecting the battery from the main generator.

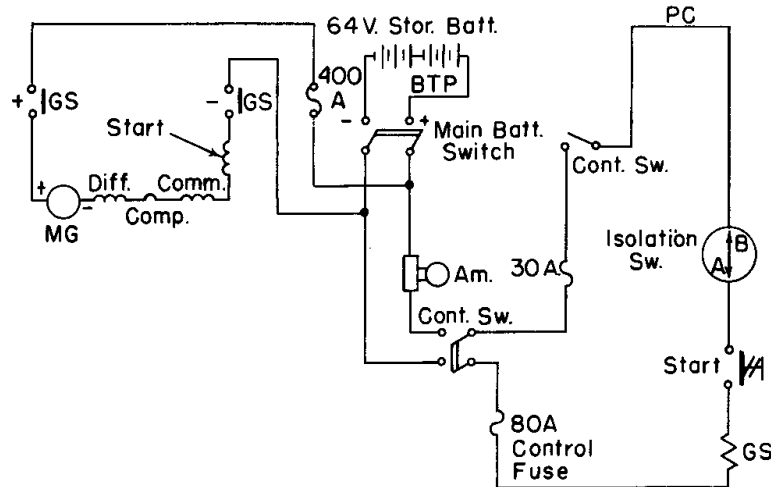

Engine Starting Circuit
Fig. 5-20

Locomotive Control Circuit (Fig. 5-21)

To get the traction motors connected to the generator, start from the "Control" switch and go down the PC wire to the second terminal point which connects to the "A" terminal of the EX contact. When the throttle is opened to the #1 position the phenolic cam drum in the controller energizes a roller switch which in turn closes the "AB" contacts leading to the EX wire. The circuit is now complete through the drum and out this EX wire to the generator field switch. Closing this switch then sends current up to the selector drum through the GF wire. All contacts of this drum are open when the selector lever is in the "OFF" position.

By placing the selector handle in the #1 position the drum activates a roller switch which closes the uppermost "CD" contact in this group. The flow of current can now proceed from the "D" terminal to the right of the reverser section of the control stand and is stopped by another set of open contacts. As the reverse lever is moved to the forward position the lower "CD" contact closes and current now flows through the FO wire and down to the RVR-F coil. This coil causes the reverser in the high voltage system to move to the forward position.

Tapping off the FO wire above the RVR-F coil another circuit is established to the power contactors by way of a path through the "CD" of RVR, "GH" of IS, "AB" of GS, "AB" of P1 and "JK" of TR to the S13 coil. just above the interlock "JK" of TR another wire is tapped off to the right and down through the "AB" of P2 to the S24 coil.

These coils close the S13 and S24 contactors in the high voltage system thereby completing the connection of the traction motors to the generator. This can be seen by looking at the left portion of the wiring

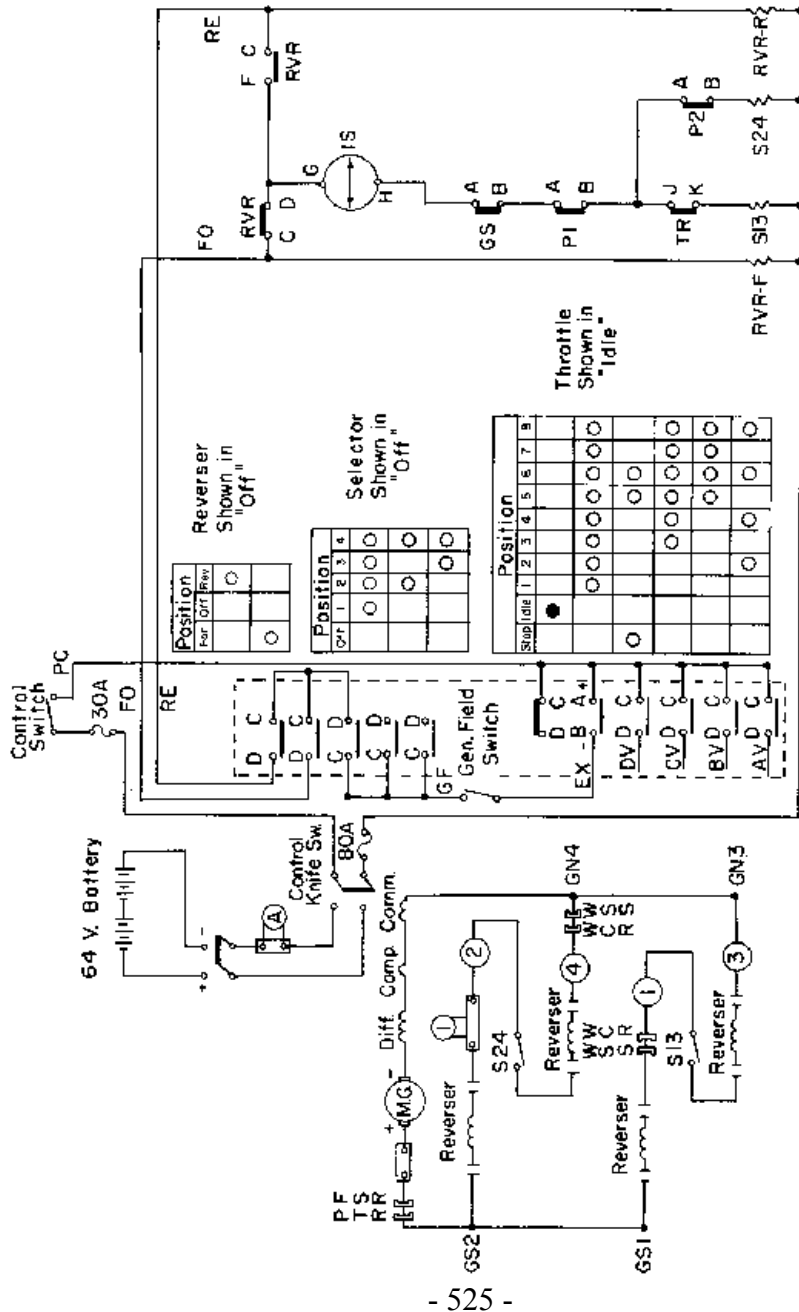

Locomotive Control Circuit
Fig. 5-21

diagram. Starting at the positive side of the main generator go to the left through the generator shunt, down to terminal GS2, turn to the right at this point and go through the reverser contacts, indicating meter shunt, field and armature of the #2 traction motor, down and to the left through the S24 contactor, down and to the right through the reverser contacts, field and armature of #4 traction motor, wheel slip control relays, to terminal GN4. At this point go up and turn back to the generator fields. A similar circuit connecting traction motors 1 and 3 to the main generator exists by the S13 contactors being closed.

Excitation Circuit (Fig. 5-22)

After connecting the traction motors to the generator the next step is to excite the generator so that it would start putting out power. This is accomplished by the excitation circuit. When the throttle is opened current flow begins in the GF wire.

Beginning at the generator field switch follow the GF wire around and down through the "EF" of IS and "GH" of GR. Continue straight down through "LM" of TR, "GH" of S13 and "GH" of S24 (which will now be closed by action of the power contactors closing in the previous circuit), AB of WS13 and WS24 to the SF coil which closes the SF contactors in the main generator circuit. Tapping off of the GF wire between the "GH" of GR and "LM" of TR the current goes to the right and down through the "AB" of SF (which will be closed by action of the SF coil just energized) and the "AB" of WSS to the BF coil. The BF coil closes the BF contactor between the battery field and load regulator. The BF contactor together with the SF contactors now completes the excitation of the generator.

Transition Circuit (Fig. 5-23)

In starting a train, the traction motors are connected in series-parallel. To connect the traction motors in series-parallel and move the locomotive, proceed as follows:

1. Place "Control" switch "ON" (current now flows through PC wire).
2. Place isolation switch in "RUN."
3. Move selector lever to No. 1 position.
4. Move reverse lever to forward or reverse (current now flows through the FO or RE wire, depending on position of reverse lever).
5. S13 and S24 contactors close (traction motors connected in series-parallel).
6. Place "Engine Run" switch "ON."
7. Place "Generator Field" switch "ON."
8. Open throttle to run position 1 or higher (current now flows through GF wire).
9. SF and BF contactors close (locomotive moves).

Series-Parallel to Series-Parallel Shunt (Transition 1-2)

As train speed increases, throttle in Run 8 position, automatic forward transition takes place as follows:

1. When the proper ratio of main generator voltage to main generator current has been reached, FSR will pick up. (Approximately 19.5 MPH in throttle eight or 18 MPH at part throttle.)
2. FSR contacts A-B close to pick up FS.
3. FSR contacts E-F close recalibrating the dropout of FSR through the 20,000 ohm resistor.

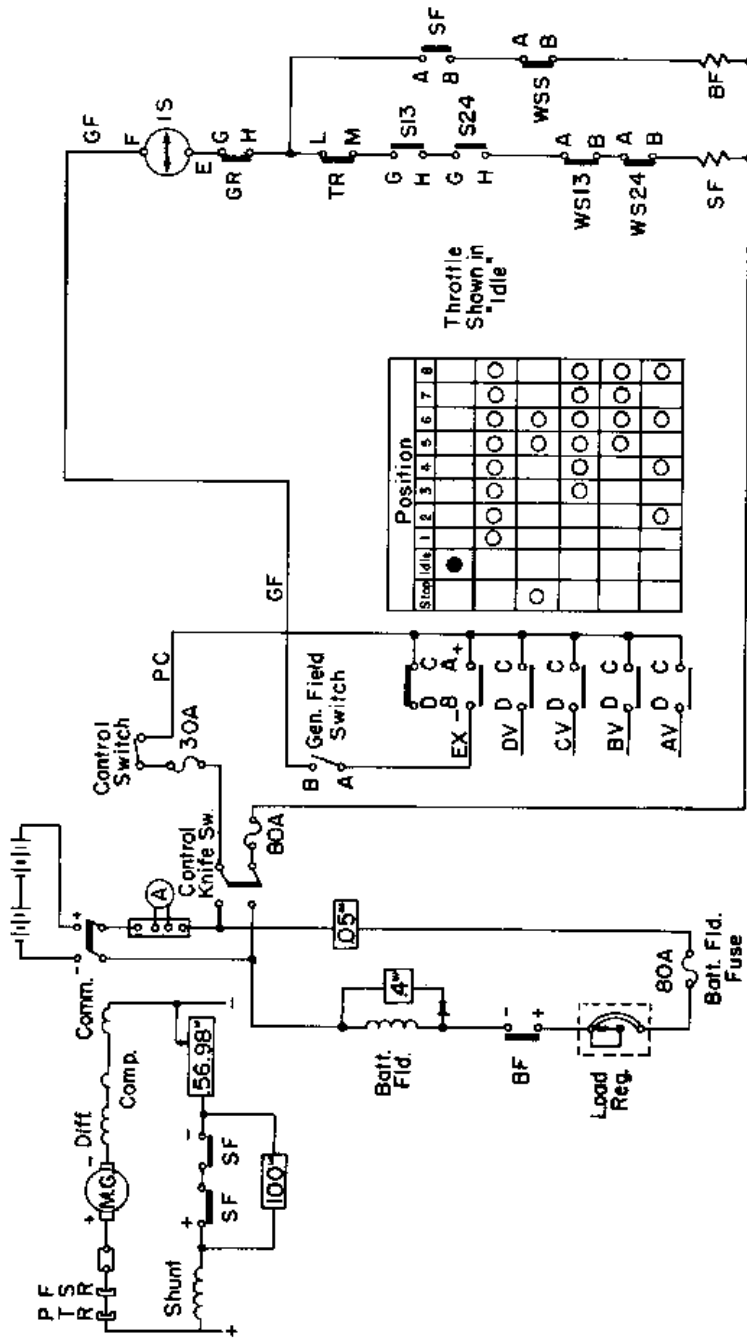

Excitation Circuit
Fig. 5-22

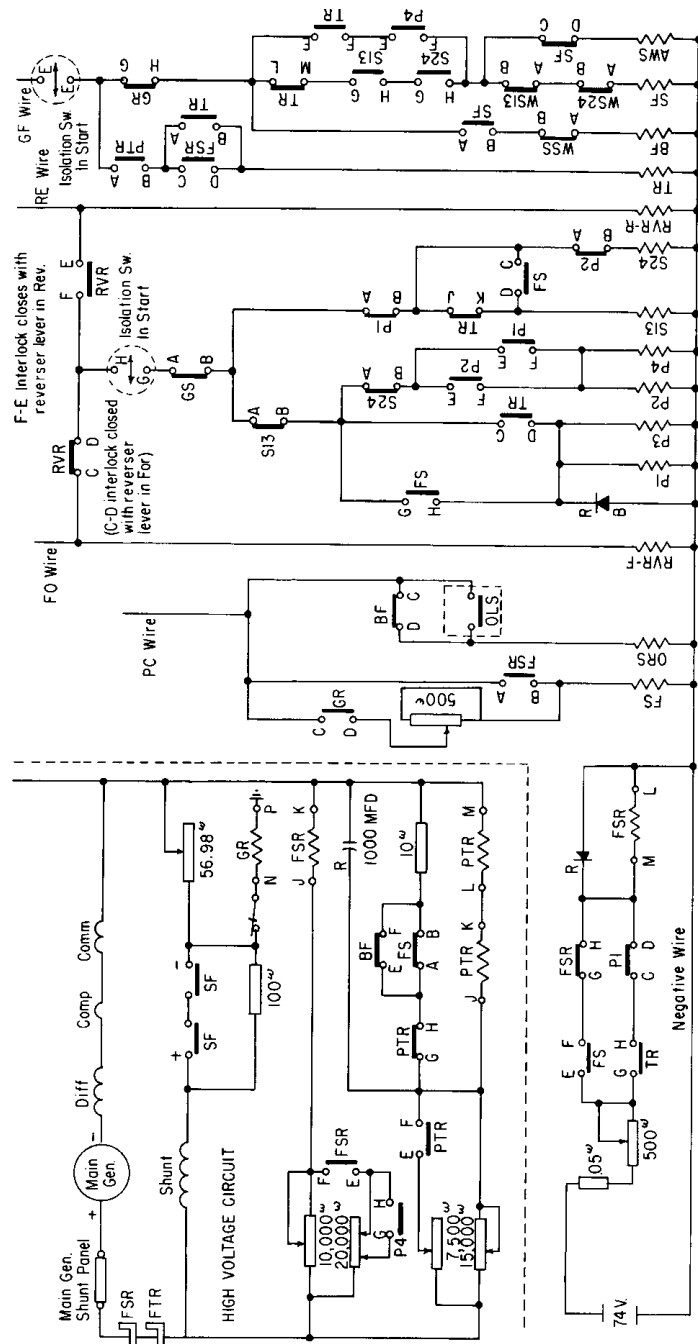

Transition Circuit
Fig. 5-23

4. FS interlocks A-B open to remove the bias around the PTR coils, j-K and L-M, allowing them to be energized when the proper ratio of main generator voltage to main generator current has been reached. The function of the 1000 MFD capacitor in parallel with the PTR coils j-K and L-M, is to delay the pickup of PTR to allow time for the main generator voltage to drop below the pickup of PTR after the motor fields have been shunted. If the pickup of PTR were not delayed, the locomotive would go into parallel below the proper speed, resulting in cycling.

Series-Parallel Shunt to Parallel (Transition 2-3)

1. At approximately 28 MPH in either part or full throttle, PTR will pick up since the proper ratio of main generator voltage to main generator current will have been reached.
2. PTR contacts A-B close to pick up TR since FSR contacts C-D are closed.
3. PTR contacts E-F close recalibrating the dropout of PTR through the 7500-ohm resistor.
4. TR contacts G-H close raising the dropout of FSR by energizing the FSR coil M-L (low voltage) in a direction opposite to that of the FSR coil J-K.
5. TR contacts A-B close establishing a holding circuit to TR around FSR contacts C-D.
6. TR contacts L-M open to drop the SF contactor.
7. SF interlocks A-B open to drop out the BF contactor. The main generator voltage will now decay at a rate controlled by the 100-ohm shunt field discharge resistor.
8. TR contacts j-k open, but S13 is held energized by FS interlocks C-D.

9. TR contacts C-D close, partially setting up a circuit to P1 and P3 contactors.
10. When the main generator voltage decays sufficiently, FSR drops out.
11. FSR contacts E-F open removing the recalibration from the FSR coil j-K.
12. FSR contacts C-D open, but TR is held in by TR contacts A-B.
13. FSR contacts A-B open, dropping FS contactor.
14. FS interlocks C-D open to drop out S13.
15. S13 interlocks A-B close to pick up P1 and P3.
16. P1 interlocks C-D open to remove the bias from the FSR coil M-L (low voltage).
17. P1 interlocks A-B open to drop out S24.
18. S24 interlocks A-B close to pick up P2 and P4.
19. P4 interlocks E-F close to pick up SF contactor since TR contacts E-F are now closed.
20. SF interlocks A-B pick up the BF contactor and the transition is complete.

Parallel to Parallel-Shunt (Transition 3-4)

1. At approximately 55 MPH train speed, FSR again picks up at the proper main generator voltage to main generator current ratio.
2. FSR contacts A-B close to pick up FS.
3. FSR contacts E-F close recalibrating the dropout of FSR through the 20,000 ohm resistor and the G-H interlock of P4.
4. FS interlocks A-B open; however, the bias around j-K and L-M coils of PTR was already removed by the G-H contacts of PTR in transition from series-parallel shunt to parallel.

Parallel Shunt to Parallel (Transition 4-3)

Assume that the locomotive is running in parallel shunt (Transition 4) in throttle eight and decelerates due to an upgrade.

1. As the train speed reaches approximately 42 MPH, FSR drops out.
2. FSR contacts G-H close to energize FSR low voltage coil M-L. This raises the ratio necessary to pick up FSR and prevents cycling due to transient high voltage.
3. FSR contacts C-D open, but TR is held in by TR contacts A-B.
4. FSR contacts E -F open to remove recalibration from FSR coil j-K.
5. FSR contacts A-B open to drop the FS contactor and remove the 48% shunt from the traction motor fields.
6. FS interlocks A-B close around the PTR coils j-K and L-M, but since PTR contacts G-H are open, PTR is not shunted out.
7. FS interlocks E-F open removing the bias from the FSR coil M-L (low voltage).

If the locomotive continues to lose speed, the ratio of main generator voltage to main generator current will rise to drop out PTR and initiate further backward transition.

Parallel to Series-Parallel to Series-Parallel Shunt (Transition 3-1-2)

1. As the train speed reaches approximately 24 MPH in throttle eight, PTR will drop out.
2. PTR contacts G-H close to short out the PTR coils and prevent them from picking up due to transient high voltage conditions.

3. PTR contacts E-F open to remove the recalibration from the 7500 ohm resistor.
4. PTR contacts A-B open to drop out the TR relay.
5. TR contacts E-F open to drop out the SF contactors.
6. SF interlocks A-B open to drop out the BF contactor. Main generator voltage will now decay at a controlled rate.
7. BF interlock E-F closes but has no effect since FS interlock A-B had closed previously.
8. TR contacts C-D open. Pi and P3 drop out approximately 0.1 second later due to the rectifier wired across their coils.
9. P1 interlock A-B closes to pick up S13 since TR contact J-K is closed.
10. S13 interlocks A-B open to drop out P2 and P4.
11. P2 interlocks A-B close to pick up S24. The traction motors are now connected in series-parallel.
12. S13 and S24 interlocks G-H close to pick up the SF contactor, since the TR contacts L-M are closed.
13. SF interlocks A-B close to pick up the BF contactor.
14. As the generator voltage rises as a result of the reclosing of SF and BF, FSR picks up which picks up the FS contactor.
15. FS interlocks A-B open to remove the shunt around the PTR coils J-K and L-M, but the 1000 MFD capacitor does not allow PTR to pick up for approximately 3.0 seconds. In effect, the coils are shunted until the capacitor is fully charged.

Assuming the locomotive continues to decelerate in throttle eight due to the grade, at approximately 17 MPH the FSR relay will drop out to initiate the final step of backward transition.

Series-Parallel Shunt to Series-Parallel (Transition 2-1)

1. FSR drops out and its G-H contacts close to energize the FSR low voltage coil M-L. This raises the ratio necessary to pick up FSR and prevent cycling due to transient high voltage.
2. FSR contacts C-D open but this has no effect since PTR contacts A-B are already open. 3. FSR contacts E-F open to remove the recalibration from FSR coil J-K.
4. FSR contacts A-B open to drop out the FS contactor and remove the 48% shunt from the traction motor fields.
5. FS interlocks A-B close and short out the PTR coils J-K and L-M since PTR contacts G-H are closed.

LEGEND OF ELECTRICAL EQUIPMENT

The following list shows abbreviations identifying electrical equipment on the locomotive and/or the wiring diagrams. The diagram wire designations conform with the identification bands on the wires in the locomotive.

The diagram shows the contactors, switches and relays as if the engine was stopped and all manual switches open. It must be remembered that when the operating coil of a contactor becomes energized the contacts and interlocks associated with that contactor will then be in a position opposite to that shown in the wiring diagram.

A	Ammeter (Battery Ammeter)	ETS	Engine High Temperature Switch
AC1, 2, 3, 4	Radiator Cooling Fan Motor Contactors	FL	Field Loop Contactor
AV, BV, CV, DV	Governor Control Solenoids	FMV or FSV	Forward Sanding Magnet Valve
AWS	Auxiliary Wheel Slip Relay	FPC	Fuel Pump Contactor
BA	Boiler Alarm Light	FS	Traction Motor Field Shunting Contactor
BC	Battery Charging Contactor	FSR	Field Shunting Relay
BF	Battery Field Contactor	GA	Gauge Light or Switch
BKT	Dynamic Brake Transfer Switch	GF	Generator Field Contactor
BKT-B	Dynamic Brake Transfer Magnet Valve - Brake	GR	Ground Relay
BKT-M	Dynamic Brake Transfer Magnet Valve - Motor	GS ±	Generator Starting Contactor
BR	Dynamic Brake Relay	I	Dynamic Brake and Load Indicating Meter
BW	Brake Warning Indicating Light	IS	Isolation Switch
BWR	Brake Warning Relay	LOS	Low Oil Pressure Switch
C	Radiator Cooling Fan Motor Overload Switch	LRC	Load Regulator Contactor.
CC	Compressor Control Magnet Valve	LRS	Load Regulator Contactor Switch (In Governor)
CCs	Compressor Control Switch	MBL	Traction Motor Blower Motor
CL	Class Light	NV	"Alternator Failure" or "No Power" Signal Light
CD	Traction Motor Lockout Switch	NVR	"No AC Voltage" Relay
COMM	Commutating Field	OLS	Governor Overload Switch
COMP	Compensating Field	ORS	Governor Over-Riding Solenoid
CR	Compressor Control Relay	OS	Low Oil Signal Light
DIFF	Differential Field	P	Parallel Power Contactor
ER	Engine Relay (ER Relay)	PCR	Pneumatic Control Relay
		PCs	Pneumatic Control Switch
		PTR	Transition Relay
		RBL	Radiator Cooling Fan Blower Motor
		RCR	Reverse Current Relay
		RMV or RSV	Reverse Sanding Magnet Valve
		RVR	Reverser Switch
		RVR-F or FOR	Forward Magnet Valve or Reverser Switch
		RVR-R or REV	Reverse Magnet Valve or Reverser Switch
		S	Series Power Contactor
		SF	Shunt Field Contactor
		SFT	Shunt Field Transfer Relay
		SMV	Shutter Magnet Valve
		SR	Signal Relay

TDS
TR
START
SWS
TCR
TS
WCR
WS
WSA
WSS

Time Delay Sanding Relay
Transition Relay
Starting Field
Summer-Winter Switch
Temperature Control Relay
High Temperature (Hot Engine) Signal Light
Wheel Creep Relay
Wheel Slip Relay
Wheel Slip Auxiliary Relay
Wheel Slip Series Relay

Electrical Symbols

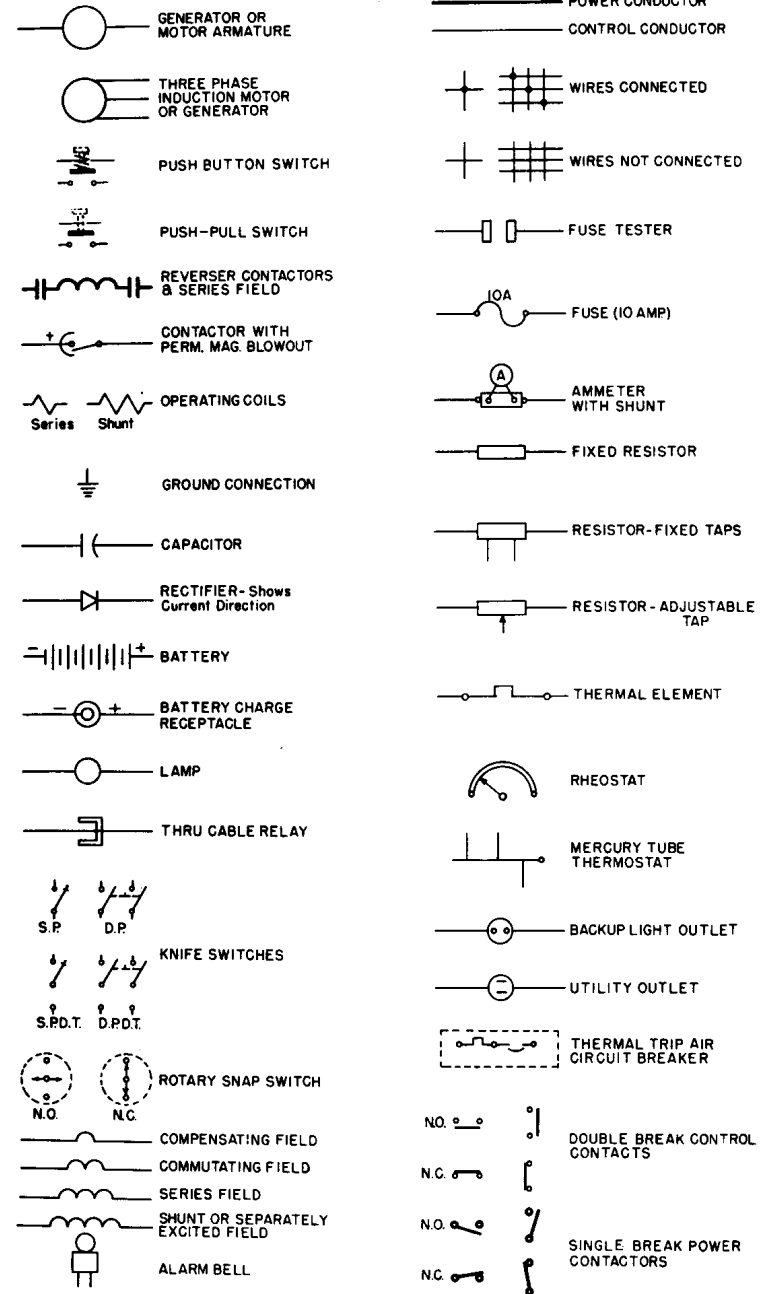

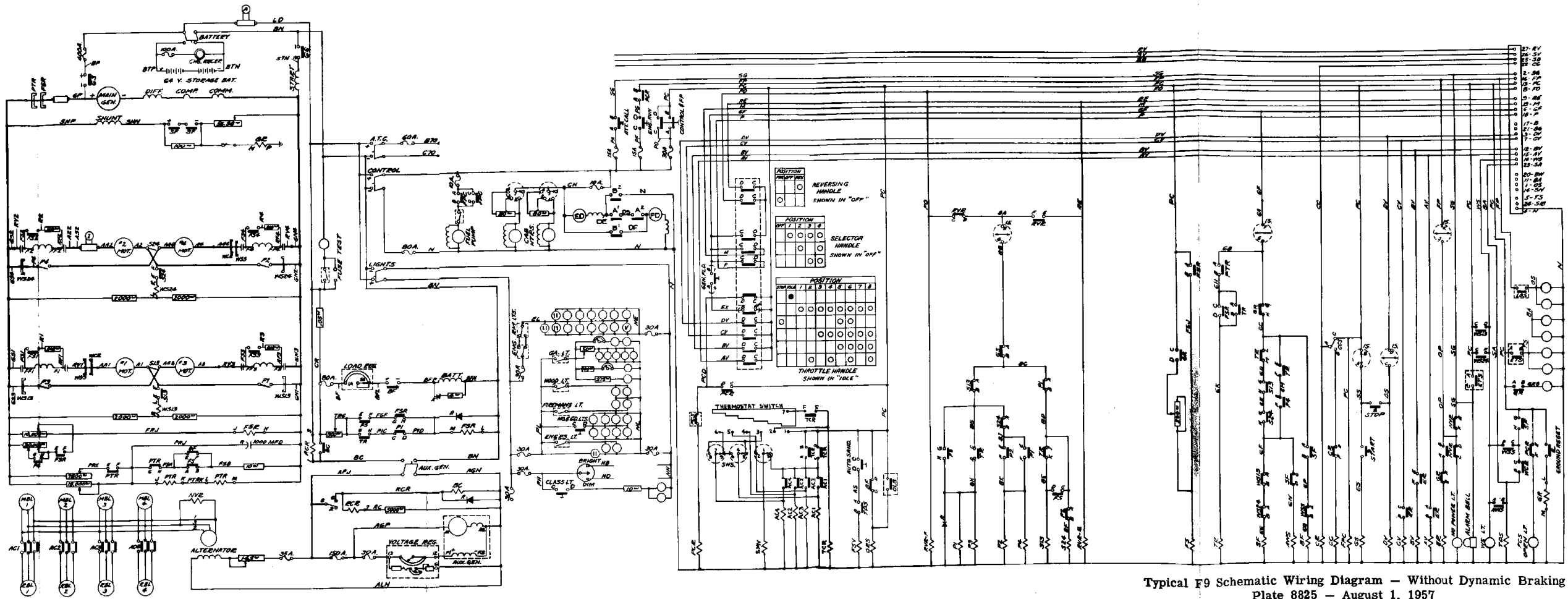

Typical F9 Schematic Wiring Diagram - Without Dynamic Braking
 Plate 8825 - August 1, 1957

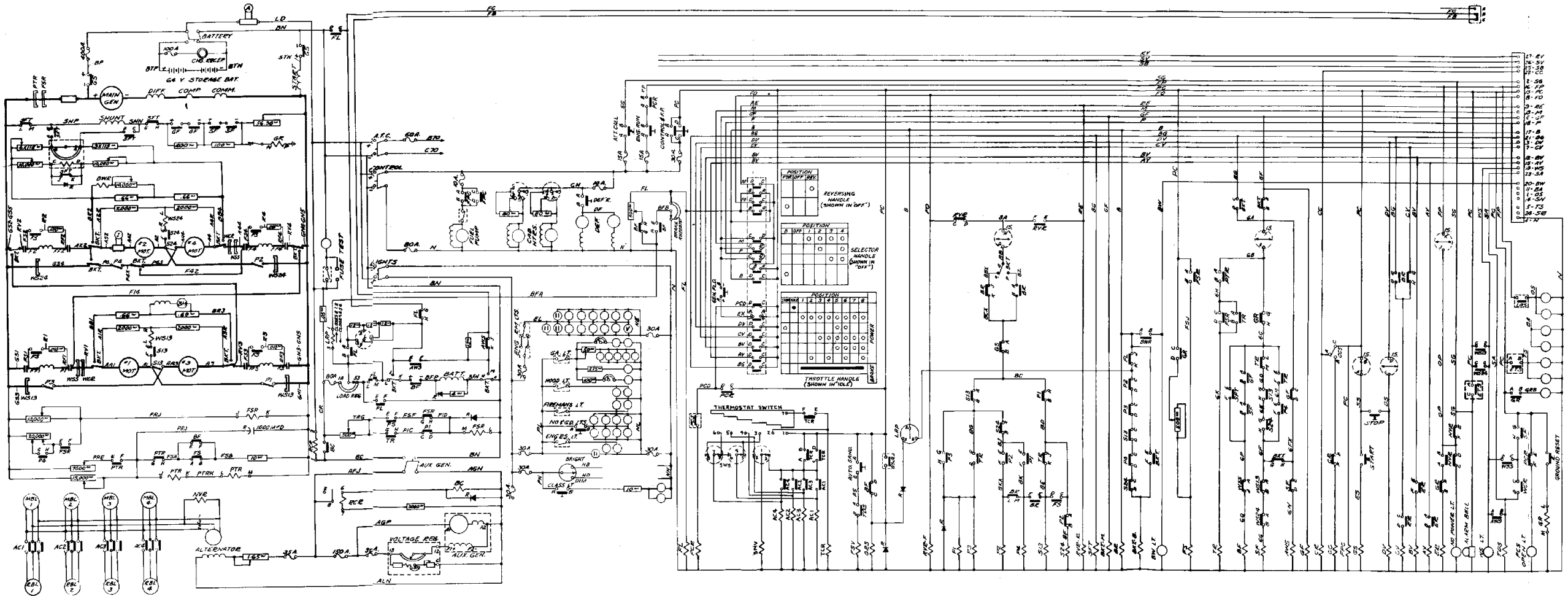

Typical F9 Schematic Wiring Diagram - With Dynamic Braking
 Plate 8845 - August, 1957