

- [DL&W F-3 Operating Manual Cover](#)
- [Title Page](#)

NOVEMBER 15, 1946

**DELAWARE, LACKAWANNA &
WESTERN RAILROAD CO.**

**DIESEL FREIGHT LOCOMOTIVES
EMD E-711, E-763
No. 655A & B, 656A & B
No. 605A, B & C, 606A, B & C**

**OPERATING MANUAL
No. 2302**



ELECTRO-MOTIVE DIVISION

**GENERAL MOTORS CORPORATION
LA GRANGE, ILLINOIS: U. S. A.**



INTRODUCTION

The purpose of this manual is to provide the engineer and fireman with information essential to the efficient and economical operation of the Diesel freight locomotive.

The manual is divided into sections. The numeral in heavy type at the top corner of each page is the section number. Section 0 contains a table of contents to the manual, locomotive general data. Section 1 covers the general description, operating controls and instruments. Section 2 covers the operation of the locomotive. The other sections, contain descriptions of the various "systems" and equipment throughout the locomotive. These sections are in loose-leaf form so that, as changes in procedures and equipment are made, revised pages may be inserted in the manual.

DELAWARE, LACKAWANNA & WESTERN RAILROAD CO.

DIESEL FREIGHT LOCOMOTIVES

GENERAL DATA

Weight (fully loaded) "A" Unit (approx)	230,000 lbs.
"B" Unit (approx)	230,000 lbs.
Fuel Oil Capacity (per unit)	1,200 gal.
Lube Oil Capacity (per engine)	200 gal.
Cooling Water Capacity "A" Unit "G" Valve Level	230 gal.
"B" Unit-"G" Valve Level	215 gal.
Sand Capacity (per unit)	16 cubic feet
Gear Ratio (655 & 656)	65/12
Gear Ratio (605 & 600)	62/ 15
Maximum Permissible Speed (655 & 656)	50 MPH
Maximum Permissible Speed (605 & 606)	65 MPH
Number of Drivers (per unit)	4 pair
Wheel Diameter	40"
Weight on Drivers	100%
Truck Centers	30' 0"
Truck Rigid Wheelbase	9' 0"
Minimum Curve Radius	274'
Center of Gravity above Rail (approx.)	63"
Length: Between Coupler Pulling Faces "A" Unit	50' 8"
"B" Unit	50' 0"
Height: Over Horns	14' 11 1/4"
Width: Outside Grabirons	10' 6 7/8"

TABLE OF CONTENTS

SECTION 0 - General

General Data
General Arrangement
Dimensions, Drains and Fillers

SECTION 1 - Description

General Description
Operating Controls
Illustration-Engineer's Controls
Engineer's Instruments
Engine Controls

SECTION 2 - Locomotive Operation

Precautions Before Starting Engine
Starting Engines After Layover
Operation of Controls and Instruments
Handling of Locomotive
Precautions During Locomotive Operation
Dynamic Brake (Used Only on Dynamic Brake
Equipped Locomotives)
Towing Locomotive
Changing Operating Ends
Locomotive Protective Devices

SECTION 3 - Cooling System

Description
Operation of Cooling System
Illustration-Cab Heating System
Illustration-Cooling and Lube Oil Systems

SECTION 4-Lubricating Oil System

Description
Operation of Lube Oil System

SECTION 5 - Fuel Oil System

Description
Operation of Fuel Oil System
Illustration-Fuel Oil System

SECTION 6 - Electrical Equipment

Description and Function of Electrical Equipment
Illustrations-Electrical Equipment
Schematic Wiring Diagram

SECTION 7 - Air System

Description and Operation of Air System
Schematic of Air System

SECTION 8 - Trucks and Miscellaneous Equipment

General Information
Truck Removal and Locomotive Lifting Diagram

SECTION 9 - Trouble Shooting

ELECTRO-MOTIVE DIVISION • GENERAL MOTORS CORPORATION
SUPPLEMENT TO OPERATING MANUALS NO. 2301-2203

SUPPLEMENT TO DIESEL LOCOMOTIVE OPERATING MANUALS NOS. 2301 AND 2302

F3 LOCOMOTIVES

The F3 model Diesel locomotive is identical in most respects to the F2 locomotive described in Operating Manuals Nos. 2301 and 2302. The differences in construction and operation are described in the following pages. For convenience, references are made to the particular sections and subjects of Manuals Nos. 2301 and 2302 which require modification for application to the F3 locomotive.

Some F3 locomotives, particularly those in passenger service, are equipped with automatic transition control. This device and its operation are described in a separate supplement entitled "Automatic Transition Control -- F3 Locomotives."

SECTION 1

GENERAL DESCRIPTION

The F3 locomotive units are rated at 1500 HP each. The increase horsepower rating is obtained by use of the D12-D14 main generator on the F3 model. The Diesel engines are the same except for the use of a different governor later described.

An electro-hydraulic governor control is incorporated in the engine governor to vary the engine speed. This replaces the electro-pneumatic governor control used on the F2 locomotives.

Operating Controls

The operating controls of the F3 locomotive are identical except that the transition lever can be moved from 2 to 3 position or 3 to 2 with the throttle in any one of the eight running positions. The transition lever can be moved into dynamic braking position when the reverse lever is in either "forward" or "reverse" position.

Engineer's Instruments

The engineer's instruments are also the same except for the Load and Transition Indicating Meter. This instrument differs only slightly from the one used on the F2 locomotives and will be described later.

SECTION 2

LOCOMOTIVE OPERATION

The operation of the F3 locomotive is similar to that described for the F2 locomotive with the exception of the following minor points:

Use of Load and Transition Indicating Meter

The meter used in the F3 locomotives has a white area only between green areas 3 and 4. Black lines separate area 1 from area 2 and area 2 from area 3. If the pointer is in the white area between 3 and 4 or exactly on one of the area dividing lines, the transition lever may be in a position corresponding to the green area on either side but the transition lever must always be shifted to a position corresponding to the green area when the pointer moves to the right of the white area or a black line.

Increasing Speed or Decreasing Speed

While the speed is increasing or decreasing, the transition lever is handled as on the F2 locomotive except that shifts are made from m1 to 2, 2 to 3, 3 to 2, and 2 to 1 when the pointer crosses a black line rather than a white area.

Operation of Transition Lever

The transition lever of the F3 locomotive is operated as described for the F2, except that the transition lever can be moved from 2 to 3 position or 3 to 2 with the throttle in any position. It is not necessary to reduce the throttle to Run 6 to make transition from No. 2 to No. 3 position or vice versa.

Continuous Tonnage Rating Figures

The continuous tonnage ratings of the F2 and F3 locomotives are the same. The approximate minimum speeds at these tonnage ratings differ as shown below:

APPROXIMATE MINIMUM SPEEDS AT CONTINUOUS TONNAGE RATINGS

Gear Ratio	65/12	62/15	61/16	60/17	59/18	58/19	57/20	56/21
F2 Locomotives	11	14.5	15.5	16.5	18	19	20.5	22
F3 Locomotives	12	15.5	17	18.5	19.5	21	22.5	24.5

Steam Locomotive Used As Helper

The locomotive operation described applies to both F2 and F3 locomotives. The Approximate Continuous Speed Ratings, used only in case the transition meter is not functioning, for the F3 differ slightly from those of the F2. The tabulation for the F3 is given below:

MILES PER HOUR WITH 40" WHEELS

Throttle	65/12	62/15	61/16	60/17	59/18	58/19	57/20	56/21
8	12	15.5	17	18.5	19.5	21	22.5	24.5
7	9.5	12	13	14	15	16	17.5	18
6	7.5	9.5	11	11.5	12	13	14	14.5
5	6	7	7.5	8	9	10	10.5	11

Operation Without Load and Transition Indicating Meter

The tabulation of speeds given for the F2 are changed slightly for the F3 model locomotive. The tabulation for the F3 is given below:

			MILES PER HOUR WITH 40" WHEELS							
Gear Ratio										
Move	Trans.	Lever								
From Pos.	to Pos.	Pos.	65/12	62/15	61/16	60/17	59/18	58/19	57/20	56/21
1	2		15	19.5	21	23	24.5	26.5	28	30
2	3		19.5	25.5	27.5	30	32	35	37	40
3	4		41	53	58.5	63	67	72	78	83
4	3		41	53	58.5	63	67	72	78	83
3	2		19.5	25.5	27.5	30	32	35	37	40
2	1		15	19.5	21	23	24.5	26.5	28	30
Maximum Permissable Speed			50	65	71	77	83	89	95	102

As stated for the F2 locomotive, transition should never be made by speedometer readings except when the transition meter is not functioning.

LOCOMOTIVE PROTECTIVE DEVICES

Low Oil Pressure Switch

Not used on F3 locomotives. See Governor Safety Control below.

Lube Oil Suction Switch

Not used on F3 locomotives. See Governor Safety Control below.

Governor Safety Control

In case of low oil pressure or high vacuum on the suction side of the lube oil and piston cooling oil pumps, the engine governor will stop the engine. The alarm bells will sound in all units of the locomotive. The yellow "LOW OIL" and the blue "ALTERNATOR FAILURE" signal lights will show in the unit concerned.

When the governor safety control stops the engine, a pushbutton on the front of the governor housing moves out approximately 3/8" exposing a red band around the shaft of the button. The governor reset push-button must be pressed in to put out the "LOW OIL" alarm lights and the

isolation switch moved to "START" position to cut out the "ALTERNATOR FAILURE" alarm lights. Both actions are necessary to stop the alarm bells.

The push-button will not trip if the engine stops due to placing of throttle in emergency stop position, operation of manual layshaft control lever, tripping of ground protective relay when throttle is in Run 5 or Run 6 or use of the "STOP" button for normal shut down. In these instances, the "LOW OIL" alarm lights will not light but the "ALTERNATOR FAILURE" alarm will function (except when the "STOP" button is used) to serve as a warning that an engine is stopped.

When the engine is stopped by governor control action, the pushbutton must be reset before the engine can be started. When the engine is started and run at idling speed, the governor will stop the engine again after approximately 40 seconds, if the condition still exists which caused the original shutdown. This time delay is provided to allow a check to determine the cause of the shutdown. However, if an attempt is made to run the engine above idling speed during the delay period, the governor will stop the engine at once should the oil pressure be low or the oil pump suction be high.

Ground, Protective Relay

The function and purpose of the ground protective relay on the F3 locomotives is the same. However, when tripped, it de-energizes the "ER Relay" in the engine control and instrument panel which, in turn, de-energizes the A, B and C solenoids in the engine speed control section of the engine governor.

SECTION 3

COOLING SYSTEM

Engine High Temperature Alarm Switch

On the F3 locomotive, the red "HOT ENGINE" alarm light will show only in the unit having high cooling water temperature. It is therefore not necessary to check the engine temperature gauges to determine which engine is causing the alarm.

SECTION 4

LUBRICATING OIL SYSTEM

Low Oil Pressure Alarm Switch

Not used on F3 locomotives. See Governor Safety Control above.

Lube Oil Suction Gauge and Alarm Switch

The same lube oil suction gauge is used on the F3 as of the F2. The alarm switch is not used. Its function is taken over by the governor safety control described above.

SECTION 6

ELECTRICAL SYSTEM

Load Regulator and Pilot Valve Operation

The load regulator and pilot valve operation on the F3 locomotives is the same as that described for the F2 except that an additional feature is provided. A solenoid (0) in the governor is energized during the time interval in which transition from 2 to 3 or 3 to 2 is taking place. The operation of this solenoid causes the load regulator to move toward minimum field in this period. This action makes it unnecessary to reduce the throttle to Run 6 while the 3 to 2 and 2 to 3 transitions are being made.

Low Oil Pressure Alarm Switch

Not used on F3 locomotives. See Governor Safety Control

Lube Oil Suction Alarm Switch

Not used on F3 locomotives. See Governor Safety Control

Electro-Pneumatic Governor Control Magnet Valves

Not used on F3 locomotives. See Electro-Hydraulic Governor Control Solenoids below.

Electro-Hydraulic Governor Control Solenoids

The function of the magnet valves in the F2 governor control is taken over by electrical solenoids incorporated in the governor. The solenoids are designated "A," "B," "C" and "D" and when energized have the same relative effect on engine speed as the magnet valves of the electro-pneumatic governor control. A fifth solenoid (0) is included in the governor which affects engine loading only and does not change engine speed. The solenoids are energized or deenergized in the various throttle positions as shown in the Engine Speed Chart for the magnet valves. This allows F3 units to be operated in conjunction with FT or F2 units in the same locomotive.

Master "E" Magnet Valve

Not used in F3 locomotives. See "ER" Relay below.

"ER" Relay

The relay performs exactly the same function in the electrohydraulic governor control that the master "E" magnet valve does in the electro-pneumatic governor control. However, the "ER" relay accomplishes this by breaking the solenoid actuating circuits when it is de-energized, preventing the solenoids from operating, and holding the engine to idling speed. As in the case of the master "E" magnet valve, the "ER" relay does not control the "D" solenoid. As a result, the engine will stop if the "ER" relay is de-energized while the throttle is in Run 5 or Run 6. The "ER" relay is de-energized due to:

- a. Control switch open in distribution panel of operating "A" unit.
- b. Main control fuse blown in distribution panel of operating "A" unit.
- c. PC switch tripped in operating "A" unit.
- d. Fuel pump fuse blown in distribution panel of operating "A" unit.
- e. Fuel pump switch open in control push-button box of operating "A" unit.
- f. Isolation switch not fully in "RUN" position in unit concerned.
- g. "No AC Voltage" relay de-energized or contacts open in unit concerned.
- h. Ground protective relay tripped in unit concerned.

NOTE: Items "a" to "e" will de-energize the "ER" relays in all units of the locomotive. Items "f" to "h" will de-energize "ER" relay in one unit only.

SECTION 7

AIR SYSTEM

Air Compressor

The air compressor of the F3 locomotive is the same as that used on the F2. However, on the F3 locomotive, compressor control system is provided which synchronizes the loading and unloading of all the compressors in the locomotive. When the pressure falls below 130 pounds in the main reservoirs of any one unit, the compressor control system will load the compressors in all the units. The compressors will continue to pump air until the main reservoir pressure reaches 140 pounds. At this point, all compressors will unload. With this control system, the main reservoir pressure cannot fall below 130 pounds in any unit.

The air line to the compressor control switch in each unit contains a cut-off valve. This valve is located in the left front corner of the electrical control cabinet. In case of difficulty with the compressor control switch in any unit, the valve can be closed to eliminate the compressor control from that unit. Its compressor will then be controlled by the action of the switches in the other units.

SECTION 9

TROUBLE SHOOTING

Loss of Load On An Engine

The indicators on the governor and electro-pneumatic governor control described for the F2 locomotive are not used on the F3 model. In place of these indicators, the side of the governor toward the left cylinder bank has two pointers with scales. When the throttle is in Run 8, the "SPEED" pointer should be at "8" and the "FUEL" pointer at "6" which is the mark halfway between "5" and "7." If the "SPEED" pointer reads higher than "6" the engine is not loading properly and the causes may be as listed for the F2 model.

If An Engine Fails To Stop

On F3 locomotives, the engine can also be stopped by pulling out the push-button on the front of the governor.

If Hot Engine Alarm Sounds

On the F3 locomotive, the "HOT ENGINE" alarm light will light only in the unit causing the alarm although the alarm bells will sound in all units. Therefore, the alarm light panels, rather than the engine temperature gauges, should be checked to determine which engine is causing the alarm.

Engine Stopped

If one engine stops due to trouble in the lubricating oil system, the alarm bells will sound throughout the locomotive and the "LOW OIL" and "ALTERNATOR FAILURE" alarm lights will show in the unit concerned. If the stoppage is due to some other cause, the "LOW OIL" lights will not light but the alarm bells will sound and the "ALTERNATOR FAILURE" light will show in the unit having the stopped engine.

To locate the trouble, if the "LOW OIL" alarm lights are lighted:

- 1. Reset push-button on governor by pressing to "In" position.
- 2. Place isolation switch in "START" position.
- 3. Start engine.
- 4. Check lube oil pressure and suction vacuum gauges carefully. If lube oil pressure is low or suction vacuum high, shut down engine immediately.
- 5. If gauges appear to be at or near normal readings, allow engine to operate at idling speed for approximately one minute. Should the engine be shut down by governor safety control during this period, do not attempt further use of the unit.
- 6. If no shutdown occurs during the delay period of the governor, put engine on the line in the usual manner. In case of shutdown by

governor action when the engine is so loaded, cut out the unit and report condition to maintenance point.

If the "LOW OIL" alarm lights have not been lighted, check for the causes listed for the F2 locomotive under "ENGINE STOPPED".

Low Oil Pressure Alarm or Lube Oil Suction Alarm

Due to action of the governor previously described, this paragraph does not apply to the F3 locomotive.

When the Alarm Is Steady

See "ENGINE STOPPED" above.

General Arrangement - "A" Unit - Fig.O-1

1.	Model 16-5678 Engine	16.	Lube Oil Filler	30.	Main Air Reservoir
2.	Main Generator and Alternator	17.	Lube Oil Cooler	31.	Air Intake and Shutters
3.	Generator Blower	18.	Engine Cooling Water Tank	32.	Steam Generator Water Filler (both sides)
4.	Auxiliary Generator	19.	Engine Control and Instrument Panel	33.	Air Intake for Grids and Engine Room
5.	Electrical Control Cabinet	20.	Load Regulator	34.	Fuel Tank Gauge
6.	Air Compressor	21.	Cooling Fan and Motor	35.	Door
7.	Traction Motor Blower	22.	Radiator	36.	Emergency Fuel Cutoff
8.	Instrument Panel	23.	Horn	37.	Engine Water Filler (both sides)
9.	Controller	24.	Exhaust Manifold	38.	Dynamic Brake Grids and Blowers
10.	Speed Indicator	25.	Sand Box	39.	Steam Generator
11.	Air Brake Valve	26.	Fuel Filler (both sides)	40.	Steam Generator Water Tank
12.	Cab Heater	27.	Headlight	41.	Steam Generator Water Softener
13.	Lube Oil Filter	28.	Batteries	42.	Coupler (Link)
14.	Hand Brake	29.	Fuel Tank	43.	Toilet
15.	Fuel Tank Vent with Flame Arrestor	44.	Engine Sump Oil Drain (left side only)	45.	Roof Water Filler (Engine)

NOTE: Steam Generator Model and Capacity at Customers Option. See General Data Page for Details.

- [General Arrangement - "A" Unit - Front](#)
- [General Arrangement - "A" Unit - Side](#)
- [General Arrangement - "A" Unit - Top, Internal](#)
- [General Arrangement - "A" Unit - Side, Internal](#)

General Arrangement - "B" Unit - Fig.O-2

1.	Model 16-5678 Engine	16.	Radiator	31.	Steams Generator Water Tank (200 Gal. Tank with 1600 Lb. Stm. Gen.) (300 Gal. Tank with 300 Lb. Stm. Gen.)
2.	Main Generator and Alternator	17.	Exhaust Manifold		
3.	Generator Blower	18.	Sand Box		
4.	Auxiliary Generator	19.	Fuel Filler (both sides)	32.	Steam Generator Water Tank for Large Steam Generators (1200 Gal.)
5.	Electrical Control Cabinet	20.	Batteries		
6.	Air Compressor	21.	Fuel Tank	33.	Steam Generator Water Tank Filler (both sides- 1200 Gal. Tank)
7.	Traction Motor Blower	22.	Main Air Reservoir		
8.	Lube Oil Filter	23.	Ali Intake and Shutters	34.	Steam Generator Water Tank Filler (both sides- 200 and 300 Gal. Tanks only)
9.	Fuel Tank Vent with Flame Arrestor	24.	Air Intake for Grids and Engine Room		
10.	Lube Oil Filler	25.	FueI Tank Gauge	35.	Air Brake Equipment
11.	Lube Oil Cooler	26.	Emergency Fuel Cutoff	36.	Roof Water Filler (Engine)
12.	Engine Cooling Water Tank	27.	Engine Water Filler (both sides)	37.	Engine Sump Oil Drain (left side only)
13.	Engine Control and Instrument Panel	28.	Dynamic Brake Grids and Blowers	38.	Coupler. (Type "E")
14.	Load Regulator	29.	Coupler (Link)	39.	Hand Brake
15.	Cooling Fan and Motor	30.	Steam Generator (1600 Lb. Capacity)	40.	Steam Generator Water Softener

NOTE: Steam Generator Model and Capacity at Customer's Option. See General Data Page for Details.

- [General Arrangement - "B" Unit - Front](#)
 - [General Arrangement - "B" Unit - Side](#)
 - [General Arrangement - "B" Unit - Top, Internal](#)
 - [General Arrangement - "B" Unit - Side, Internal](#)
-

Dimensions, Drains and Fillers - "A" Unit - Fig. O-3

- 1. Pulling Face of Front Coupler.
- 2. Blocking Pads-both sides under pilot.
- 3. Sand Box Fillers-two on each side of car.
- 4. Jacking and Blocking Pads-both sides No. 1 bolster under carbody.
- 5. Battery Charging Receptacle-left side only.
- 6. Battery Box-both sides under carbody.
- 7. Engine Air Box Drain-both sides under carbody, valves at each side of engine under oil pan handhole covers No. 7 and 15.
- 8. Fuel Tank-under carbody.
- 9. Fuel Tank Water Drain Valve-both sides in tank sump.
- 10. Fuel Tank Sump Drain Plug-in tank sump.
- 11. Fuel Gauge-both sides in side skirt.
- 12. Fuel Filler-both sides in side skirt.
- 13. Fuel Tank Drain Plug-in bottom of tank sump.
- 14. Engine Sump Oil Drain-left side, valve and drain under carbody.
- 15. Engine Water Drain-under carbody, valve inside carbody.
- 16. Jacking and Blocking Pads-both sides No. 2 bolster under carbody.
- 17. Engine Oil Strainer Drain-left side under carbody, valve inside carbody.
- 18. Engine Water Filler-both sides under carbody at rear of car.
- 19. Steam Generator Water Tank Filler (200 and 300 gal. tanks)-both sides under carbody at rear of car.
- 20. Blocking Pads-both sides under carbody at rear of car.
- 21. Engine Roof Water Filler-on roof of car above engine cooling water tank.

[Side View - "A" Unit](#)

Dimensions, Drains and Fillers - "B" Unit - Fig. O-4

- 1. Blocking Pads-both sides under carbody at front of car.

- 2. Sand Box Fillers-two on each side of car.
- 3. Jacking and Blocking Pads-both sides No. 1 bolster under carbody.
- 4. Battery Charging Receptacle-left side only.
- 5. Steam Generator Water Tank Filler (1200 gal. tank)both sides.
- 6. Battery Box-both sides under carbody.
- 7. Engine Air Box Drain-both sides under carbody, valves at each side of engine under oil pan handhole covers No. 7 and 15.
- 8. Fuel Tank-under carbody.
- 9. Fuel Tank Water Drain Valve-both sides in tank sump.
- 10. Fuel Tank Sump Drain Plug-in tank sump.
- 11. Fuel Gauge-both sides in side skirt.
- 12. Fuel Filler-both sides in side skirt.
- 13. Fuel Tank Drain Plug-in bottom of tank sump.
- 14. Engine Sump Oil Drain-left side, valve and drain under carbody.
- 15. Engine Water Drain-under carbody, valve inside carbody.
- 16. Jacking and Blocking Pads-both sides No. 2 bolster under carbody.
- 17. Engine Oil Strainer Drain-left side under carbody, valve inside carbody.
- 18. Engine Water Filler-both sides under carbody at rear of car.
- 19. Steam Generator Water Tank Filler (200 and 300 gal. tanks) - both sides under carbody at rear of car.
- 20. Blocking Pads-both sides under carbody at rear of car.
- 21. Engine Roof Water Filler-on roof of car above engine cooling water tank.
- 22. Pulling Face of Rear Coupler.

[Side View - "B" Unit](#)

E
M
D
F
2
-
F
3

M
O
D
E
L
S



Operating Manual



ELECTRO-MOTIVE DIVISION
GENERAL MOTORS CORPORATION • LA GRANGE, ILLINOIS, U. S. A.

NOVEMBER 15, 1946

DELAWARE, LACKAWANNA &
WESTERN RAILROAD CO.

DIESEL FREIGHT LOCOMOTIVES

EMD E-711, E-763

No. 655A & B, 656A & B

No. 605A, B & C, 606A, B & C

OPERATING MANUAL

No. 2302



ELECTRO-MOTIVE DIVISION
GENERAL MOTORS CORPORATION
LA GRANGE, ILLINOIS, U. S. A.

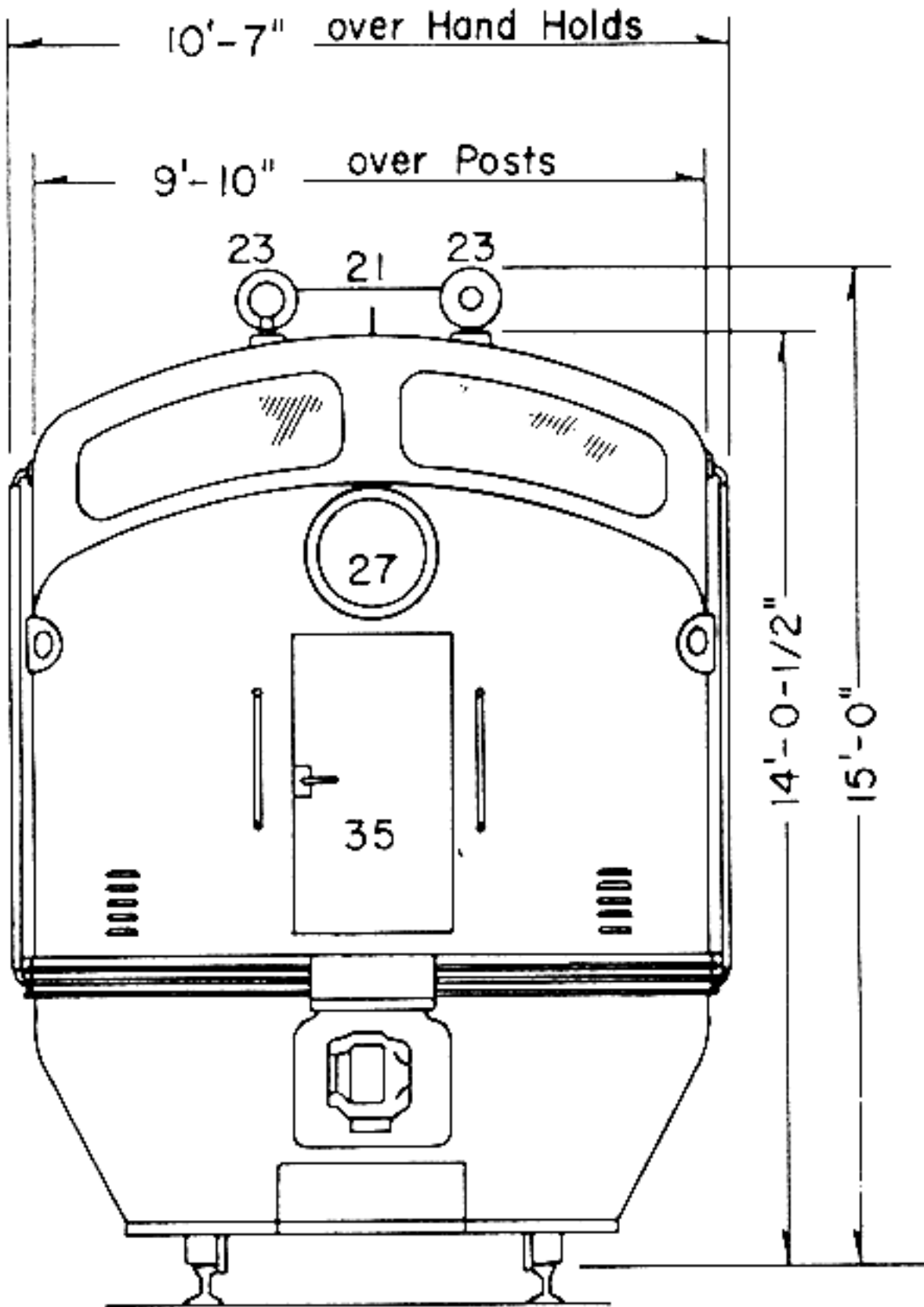

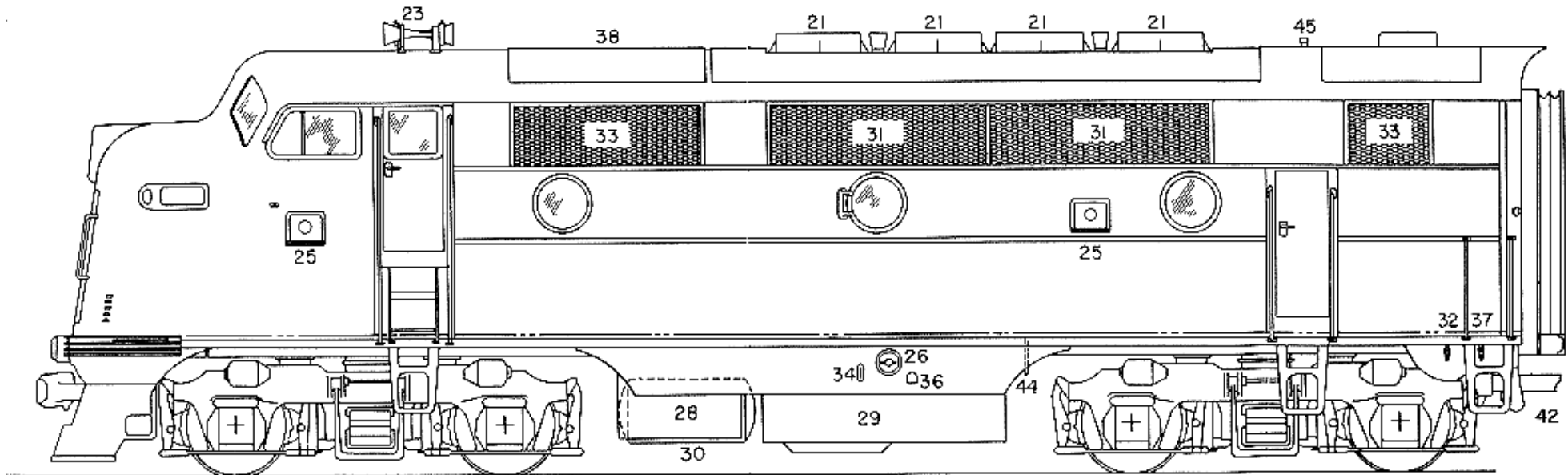

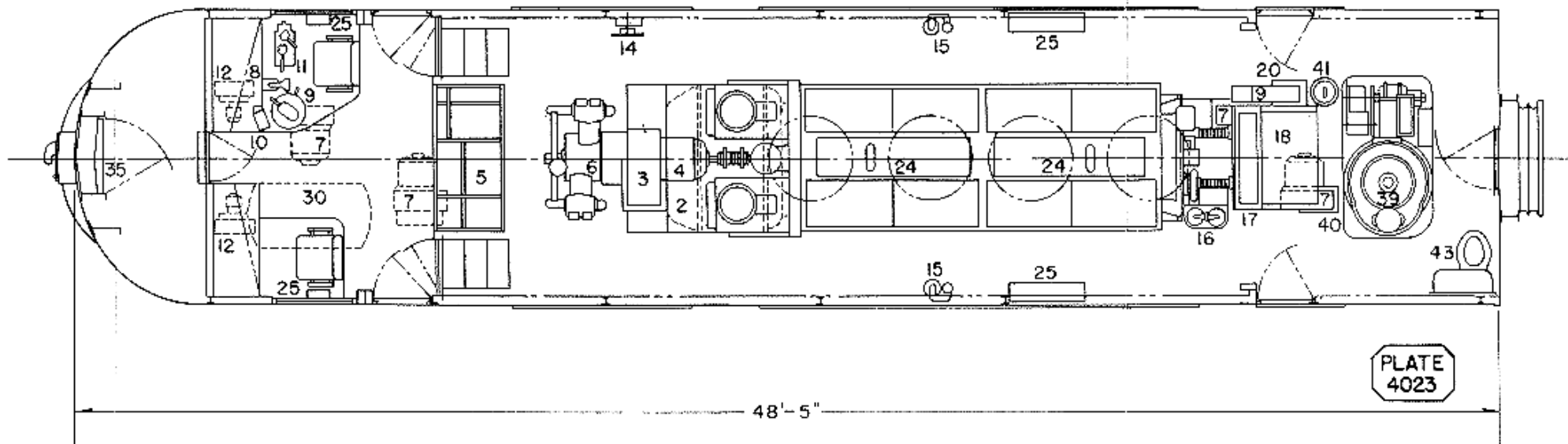

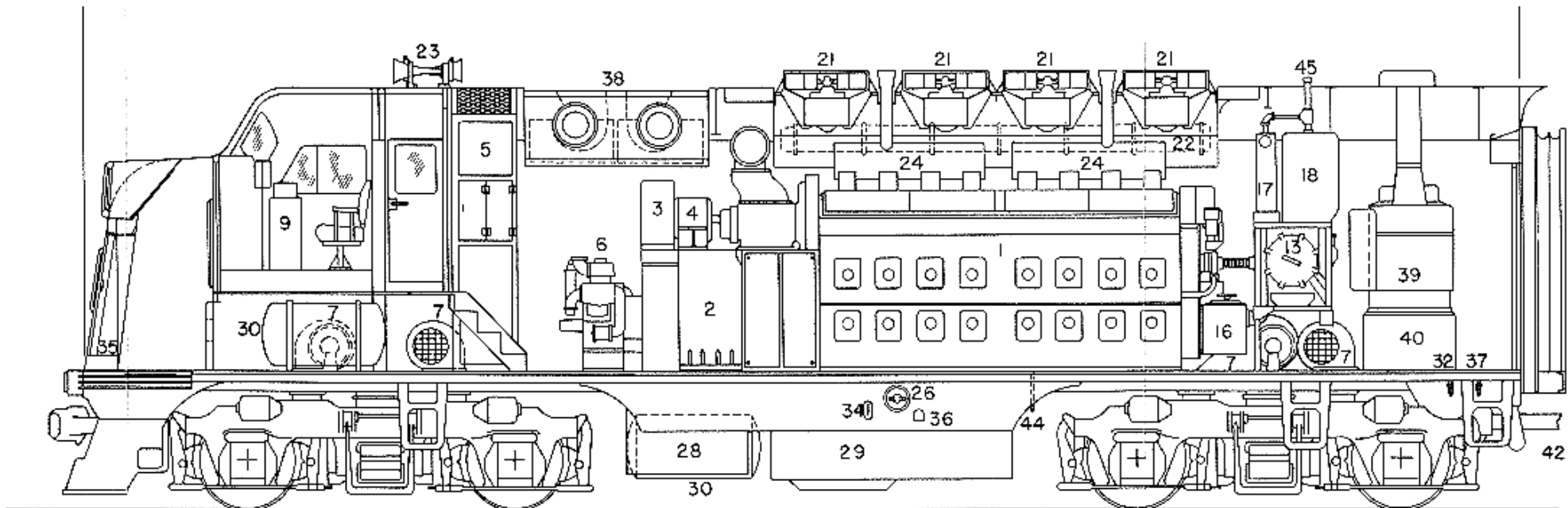

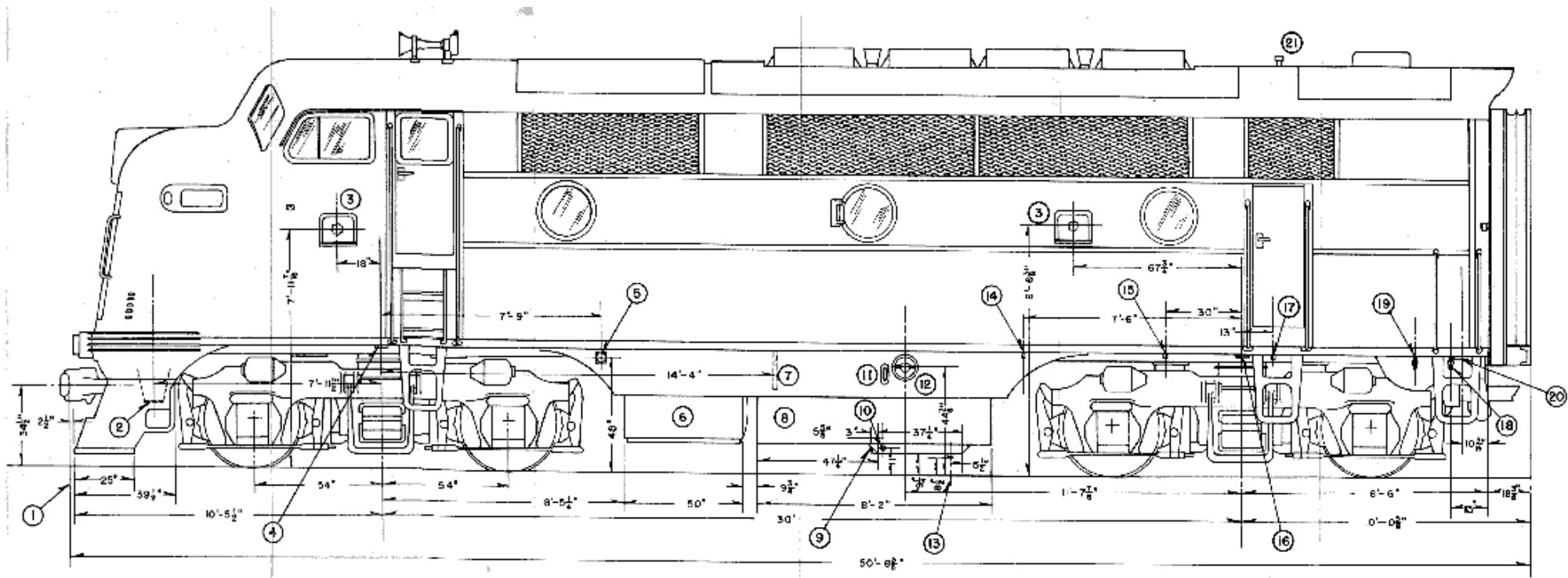

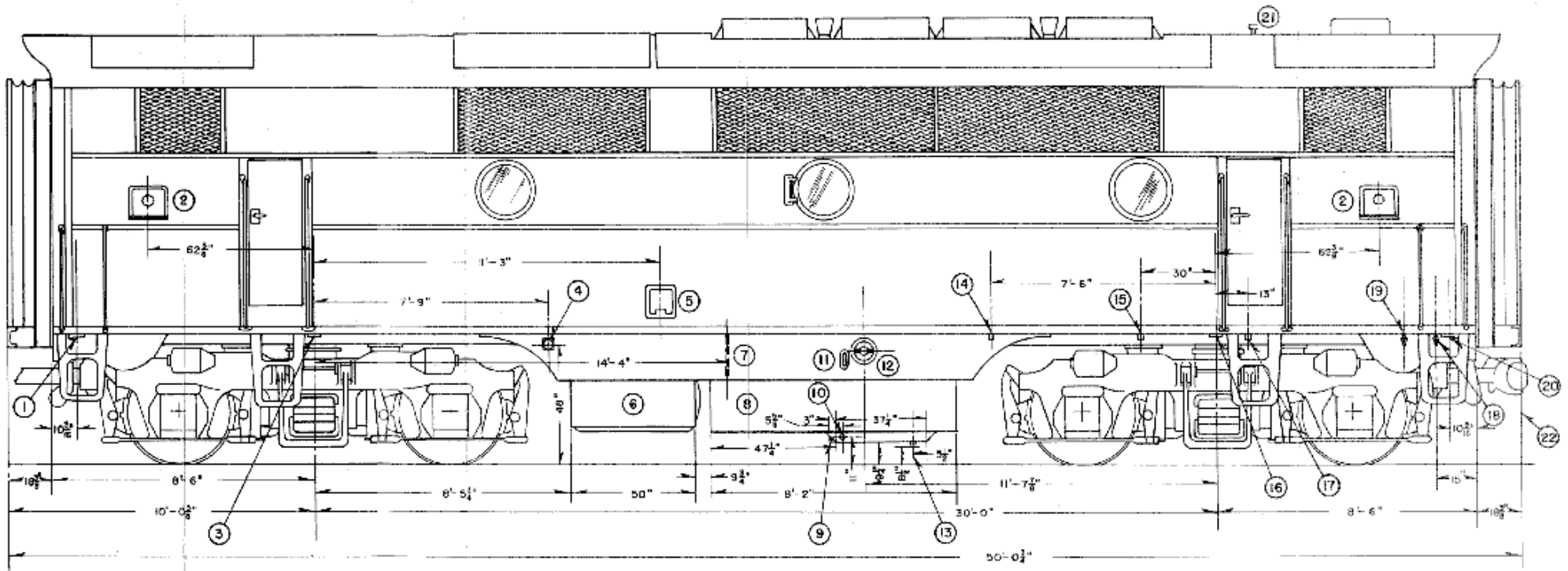

ELECTRO-MOTIVE DIVISION
SECTION F2-1-1

• GENERAL MOTORS CORPORATION
DESCRIPTION

SECTION 1

GENERAL DESCRIPTION

The freight locomotive consists of one or more units rated at 1350 HP each. The units with the cab are known as "A" units, those without the cab as "B" units. Each unit has one 16-cylinder Diesel engine, a direct current generator, an A.C. alternator, and four traction motors. From each power plant the power is distributed to the traction motors which are mounted on the trucks. The traction motors are geared to the axle through spur gears. The units are electrically independent of each other except for certain low voltage wiring. All units have batteries and are independent of each other for this service.

The engines are "V" type with a 45 deg angle between banks and have a compression ratio of 16 to 1. Solid unit injection is employed, there being an injector centrally located in each cylinder head. The engines have a speed range of 275 to 800 RPM. Their speed is controlled by an electro-pneumatic governor control which is operated by the engineer's throttle. In this way, all engines in locomotives of two or more units are controlled simultaneously. Each notch on the engineer's throttle changes the engine speed ap

ELECTRO-MOTIVE DIVISION
SECTION F2-2-1

GENERAL MOTORS CORPORATION
OPERATION

SECTION 2

LOCOMOTIVE OPERATION

Precautions Before Starting Engine

- 1. Check position of all valves:
 - a. Drain valves in engine cooling system, lube oil system, and air reservoirs (valves should be closed).
 - b. Steam admission valves in engine cooling system and steam line (valves should be closed).
- 2. Check fuel supply (gauge on engine control and instrument panel).
- 3. Check engine cooling water supply (sight glasses on engine cooling water tank).
- 4. Check lubricating oil supply:
 - a. In Diesel engine sumps (bayonet gauge on left side of engine oil pan).
 - b. Engine governors (sight glass on governor).
 - c. Air compressors (bayonet gauge in crankcase).
- 5. Close battery charging switches in electrical control cabinets,

Starting Engines After Layover

- 1. At Distribution Panel:
 - a. Be sure all control fuses are in place.
 - 400-Ampere - Starting
 - 80-Ampere - Control
 - 30-Ampere - Control
 - 15-Ampere -Fuel Pump
 - b. Close main battery switch.
 - c. Close master control switch.
 - d. Close light or train control-speed governor switch as required.
- 2. At Engineer's Control Station:
 - a. Place throttle in "IDLE" position.
 - b. Close control push-button switch.
 - c. Close fuel pump switch.
 - d. Set "PC" switch.
- 3. At Engine:
 - a. Test for water accumulation in cylinders. Open cylinder test valve at each cylinder. Place isolation switch in "START" position and fuel pump switch in "OFF." Hold governor power piston in "shut-down" position, by use of layshaft manual control lever, and turn engine several revolutions

by pressing the engine "START" button. If discharge of water or fuel appears at the test valves, do not start engine until cause of the discharge is located and corrected.

- b. Close cylinder test valves.
- c. Check 10-ampere fuel pump motor fuse on distribution panel.
- d. See that isolation switch is in "START" position,
- e. Close fuel pump switch on engine control and instrument panel and watch for fuel in sight glass nearest engine on sintered bronze filter assembly on front of engine. This will indicate that fuel is circulating through engine fuel oil system.
- f. Press engine "START" button and hold in until engine starts. If engine fails to start after being rotated 10 to 15 seconds, release "START" button and ascertain cause of difficulty.
- g. After lubricating oil pressure builds up, place isolation switch in "RUN" position.
- h. Allow engine to idle until water temperature comes up to 125 deg F., before moving locomotive.
- 4. At Electrical Control Cabinet:
 - a. Check "starting" contactors and make certain both are open.
 - b. Check ground protective relay and make certain it is not tripped.

Pumping Up Main Reservoir Air Pressure

If the locomotive has been standing inoperative and the air reservoirs have been drained:

- a. Close all drain cocks in air system.
- b. Place reverse lever in the "neutral" position.
- c. Place independent brake valve in "application" position (this will prevent "PC" switch from tripping).
- d. Start engines in the usual way but do not close the generator field switch.
- e. Let engines idle for at least five minutes.

To Move Locomotive:

- a. Release all hand brakes.
- b. Isolation switch on engine control panel must be in "RUN" position.
- c. Close generator field switch on engineer's control push-button switch box.
- d. Place reverse lever in "forward" or "reverse" position as required.
- e. Place transition lever in No. 1 position.
- f. Place foot on deadman foot pedal and release air brakes.
- g. Open throttle as required.

If locomotive has been coupled to train and train line must be pumped up:

- a. Place reverse lever in "neutral" position.
- b. Pull out generator field switch.
- c. Place transition lever in No. 1 position.
- d. Open throttle. if necessary, to 3rd position.
- e. After air has been pumped up, close throttle and push generator field switch in.

Starting A Train

Due to the unusual amount of starting tractive effort of this locomotive, it is highly essential that no attempt be made to start the train before the air brakes are completely released. Tests on a 100-car train have indicated that this time may be as much as 9 minutes after the brakes have started to release. It is recognized, however, that a normal 100-car train should not require more than five (5) minutes for the complete release of the brakes.

It is never necessary to move the throttle or any other controls hastily. Each move should be thought out carefully and made smoothly.

With the high tractive effort at starting of this locomotive, it is seldom necessary to bunch slack. If a tight train will not start, look for air brake trouble. Bunching slack and starting with a jerk might result in damaged couplers.

Caution should be observed in ordinary handling of the throttle so that the throttle "STOP" button is not pressed in error when closing the throttle. If this is done, the engines will stop and cause a delay while restarting.

When two "A" units are used to make up a locomotive, caution **MUST** be taken not to leave the reverse lever in the controller of the trailing "A" unit. If the lever is left in the controller, it might accidentally be moved, causing a flash-over, sliding the wheels, or both.

Proceed in general as follows:

- a. Place transition lever in No. 1 position.
- b. Open throttle to whatever position is necessary to start the locomotive and begin to move the train, holding the throttle in each position for approximately 2 seconds (not more than 3 seconds) before moving it to the next position. See NOTE below.
- c. After the locomotive starts, reduce the throttle (if necessary) to a position which will just keep the locomotive moving until all the slack is out. The throttle may then be advanced to any desired position.

When starting a train with the slack bunched or partially bunched, it should seldom be necessary to open the throttle beyond the No. 4 position on a four-unit locomotive, and No. 5 on a two-unit or threeunit locomotive. If the locomotive fails to start, or stops while taking slack in these throttle positions, sticking brakes may be the cause of difficulty.

If the slack is stretched or a start is being made on a grade, it may be necessary to advance the throttle to positions beyond those given above for the different locomotive unit combinations. Judgment must be exercised in handling the throttle in such cases, particularly with four-unit locomotives, to avoid pulling of drawbars. See NOTE below. NOTE: If slipping occurs, as indicated by the wheel slip indicator flashing on and off, ease off on the throttle until slipping stops and then apply sand. **DO NOT APPLY SAND UNTIL AFTER THE WHEEL SLIPPAGE HAS STOPPED.** The throttle may again be advanced to the positions at which slipping took place and the throttle movement continued if no slippage occurs.

Operating Reverse Lever

UNDER NO CONDITION should the reverse lever be moved while the locomotive is in motion. When leaving the locomotive, the reverse lever should be removed from the controller. If two "A" units are used in making up the consist of the locomotive, the reverse lever should always be removed from the controller of the trailing "A" unit.

There is no mechanical connection between the reverse lever on the controller and the reverser drums in the electrical control cabinets. The reverser drums are operated by electro-pneumatic control from the operating cab.

When the transition lever is in "OFF" position, the reverser drums will NOT move to "forward" or "reverse" position when the reverse lever is operated in the cab. When the transition lever is in No. 1 position, the reverser drums will not change when the reverser lever is moved unless the throttle is opened to Run 1. For this reason care must be used when a locomotive is backed onto a train on a hill, or when in doubleheading, the Diesel locomotive is next to the train. If gravity, or in the second case, the lead locomotive is allowed to start the train, the reverser drums of the Diesel locomotive may be in back-up position, even with the reverse lever in "forward." To prevent this condition, the transition lever should be moved to "OFF" or the throttle opened to Run 1 when the reverse lever is moved to "forward" after the coupling is made.

Use of Load and Transition Indicating Meter

The load and transition indicating meter has four green areas on its dial, numbered to correspond to the transition lever positions, and a red and yellow overload area. See Fig. 2-1. The green areas are separated by small white areas. A pointer moves across the face of the meter when the locomotive is under power.

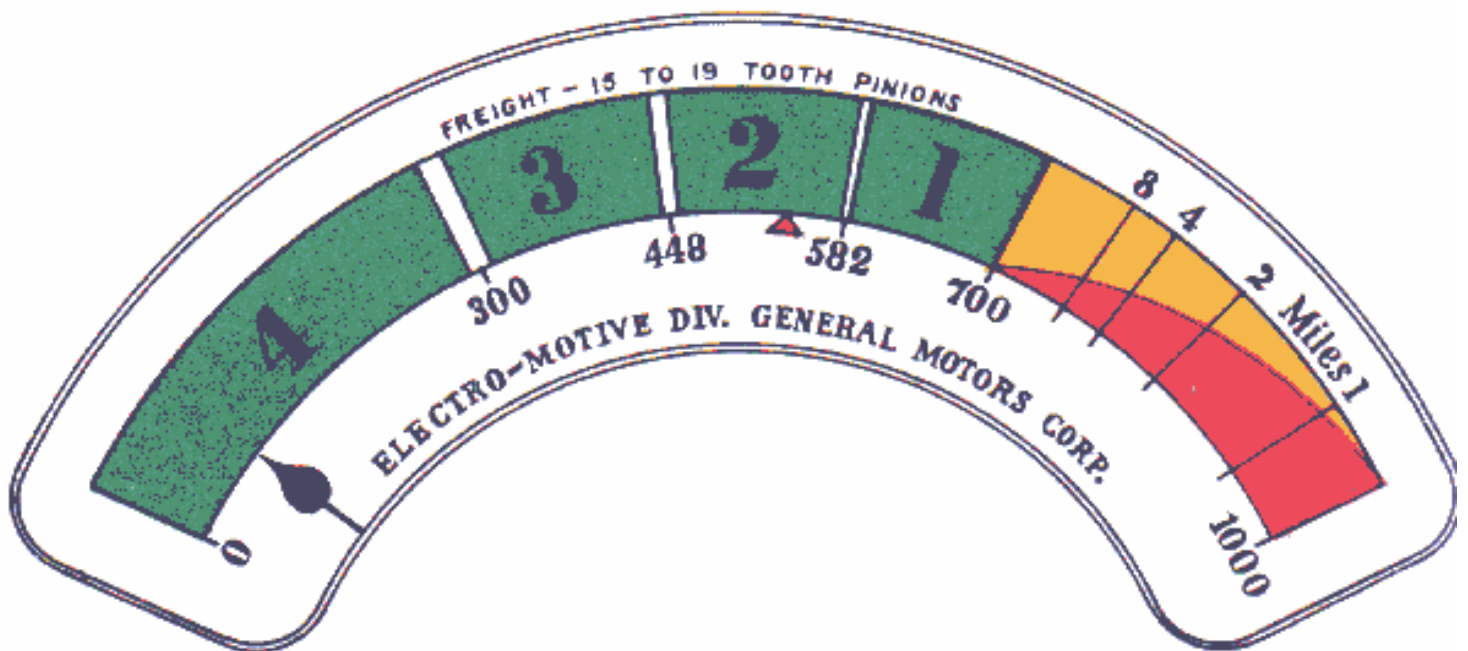

Load and Transition Indicating Meter

Fig. 2-1

Each white area between the numbered green areas represents the maximum continuous current of the traction motors with the transition lever in a position corresponding to the green area to the left of the pointer. As long as the pointer is in the white area, the transition lever may be in a position corresponding to the green area on either side, but the transition lever **MUST** always be shifted to a position corresponding to the green area when the pointer moves to the right of any white area.

The overload area to the right of No. 1 green area indicates overload with the transition lever in No. 1 position. The diagonal line separating the yellow and red areas indicates the severity of overload and the area is marked off with vertical lines representing the maximum number of miles which may be run with the meter indicating various overloads without damage to the equipment. For example, with the meter reading at the 2-mile mark, the locomotive may be operated a maximum of 2 miles without damage to the electrical equipment.

NOTE: ON ANY GRADE OR SERIES OF GRADES, IT SHOULD BE UNDERSTOOD THAT THE OVERLOAD RATINGS ARE NOT TO BE INTERPRETED AS BEING CONSECUTIVE RATINGS. THAT IS, THE LOCOMOTIVE MUST NOT UNDER ANY CIRCUMSTANCES BE OPERATED AT THE ONE-MILE RATING FOR ONE MILE, THEN THE TWOMILE RATING FOR TWO MILES, THEN THE FOUR-MILE RATING FOR FOUR MILES, ETC. IF THE TRANSITION METER POINTER EXCEEDS THE SHORT TIME RATINGS AS INDICATED ON THE METER, THEN THE TONNAGE MUST BE REDUCED.

Increasing Speed

The locomotive **MUST** always be started with the transition lever in the No. 1 position. As the throttle is opened when starting a train from a standstill, the transition meter pointer will swing to the right, indicating a high traction motor current. If the throttle is left in this position, the pointer will gradually move to the left as train speed increases. The pointer will react in the same manner with each succeeding advance in throttle position. With the throttle in Run 8 position, as the pointer moves to the left and crosses the white area between the No. 1 and No. 2 green areas, the transition lever should be moved to the No. 2 position. This procedure should be followed when the pointer crosses each succeeding white area. The pointer should always be in the numbered area corresponding to the position of the transition lever with the throttle in the Run 8 position, and in this area, or to the left of it, in any lower position of the throttle.

Decreasing Speed

As the train speed decreases due to a grade, the pointer will gradually move to the right. When the pointer crosses a white area, the transition lever **MUST** be moved to the position indicated. This **MUST** be done regardless of the throttle position.

No damage will result in failing to advance the transition lever with increasing speed. But the electrical equipment will be overloaded and serious damage might result if the lever is not backed off at the point indicated when the locomotive speed is decreasing due to a grade. The transition lever should be in the No. 1 position before the locomotive comes to a stop.

Operation of Transition Lever

The transition lever, located on the, top of the controller, has four positions to give four connections of the traction motors.

A definition of transition is inserted at this time so that the term will not be confusing. Transition is the changing of the traction motor connections to obtain the desired locomotive tractive effort and speed.

These positions are:

No. 1 SERIES-PARALLEL

No. 1 and No. 4 traction motors are connected in series. No. 2 and No. 3 motors are also connected in series. In the No. 1 position of the transition lever, these two groups are then connected in parallel.

No. 2 SERIES-PARALLEL-SHUNT

The same as Series-Parallel but with the fields of each motor shunted by resistors.

No. 3 PARALLEL

All four motors are connected in parallel.

No. 4 PARALLEL-SHUNT

The same as Parallel but with the fields of each motor shunted by resistors.

The transition lever slides in a slot which is notched both top and bottom. The lever has lugs on the top and bottom which engage in these notches, so that the lever can only be moved from one notch to the next by proper manipulation. The lug on the top is integral with the lever, while the lug on the bottom can be depressed up into the lever.

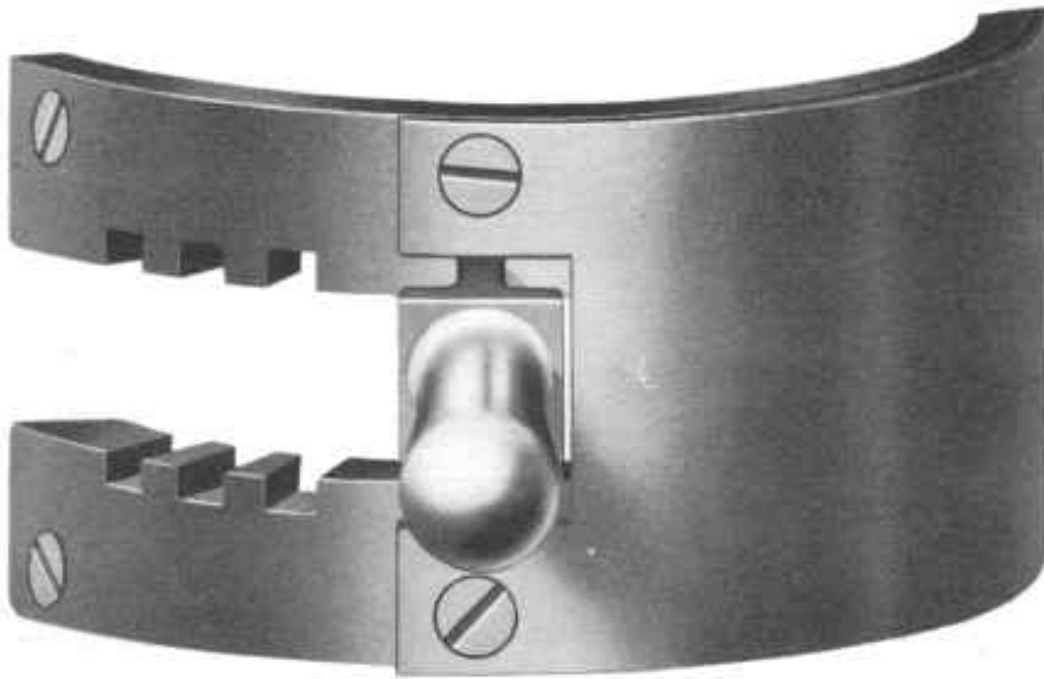

Transition Lever and Sectors

Fig. 2-2

See Fig. 2-3. To move the lever from one position to the next, the lever is lifted (A) and while it is held up against the top of the slot (B), it is moved in the direction desired with the lever held against the top and side of the upper slot (C). The lever is then lowered (D) which compresses the bottom lug (E) allowing the lever to be moved to the next position (F).

NOTE: The transition lever cannot be moved from 2 to 3 position or 3 to 2 position with the throttle in the 7th or 8th position.

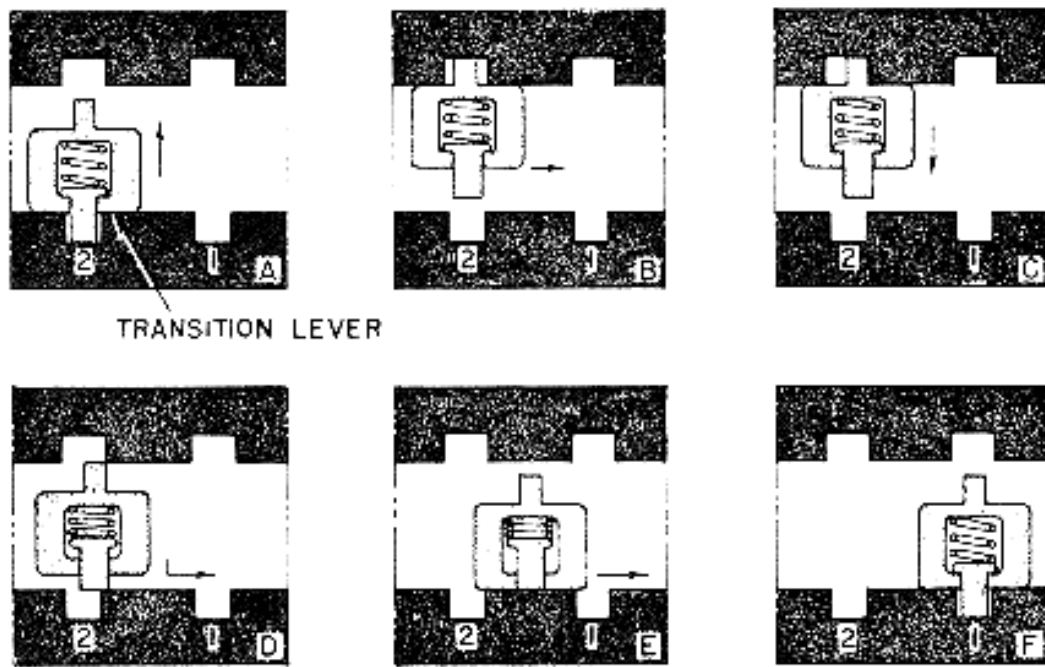

**Transition Lever Operating Diagram
Fig. 2-3**

CONTINUOUS TONNAGE RATING
FIGURES

FOR F2 LOCOMOTIVE

HP	GRADE			GEAR RATIO					
	58/19	57/20	56/21	65/12	62/15	61/16	60/17	59/18	
5400				1.0%	6450	4780	4370	3960	3700
3370	3110	2880		1.5%	4470	3280	3000	2700	2520
5400	2100	1920		2.0%	3360	2460	2230	2000	1870
1680	1540	1440		1.0%	4840	3580	3280	2970	2770
4050	2330	2160		1.5%	3350	2460	2250	2020	1890
1710	1570	1440		2.0%	2520	1840	1670	1500	1400

1260	1150	1080							
2700			1.0%	3220	2390	2180	1980	1850	
1680	1550	1440							
2700			1.5%	2230	1640	1500	1350	1260	
1140	1050	960							
2700			2.0%	1680	1230	1110	1000	930	
840	770	720							
1350			1.0%	1610	1190	1090	990	920	
840	780	720							
1350			1.5%	1120	820	750	670	630	
570	520	480							
1350			2.0%	840	610	560	500	470	
420	380	360							

APPROXIMATE SPEEDS AT ABOVE RATINGS:

11.0	14.5	15.5	16.5	18.0
19.0	20.5	22.0		

These speeds **MUST NOT** be used for rating the tonnage, but only to give a close approximation of the running speed with rated tonnage.

With the above tonnage ratings, all engines must be up to full rated output. If an engine is low in power, or an engine is "off the line," the tonnage should be adjusted in proportion to the decreased power.

In order to avoid overloading the electrical equipment, it is important that the tonnage of the train be kept within the maximum tonnage rating limits of the locomotive except where **SPECIAL TONNAGE RATINGS** have been supplied to the railroad by the Engineering Department of ElectroMotive Division.

Steam Locomotive Used As Helper

In moving large tonnage trains over heavy grades ordinarily encountered in mountainous territories, steam locomotives are generally used for helper service. In such a movement, it must be known that the steam locomotive can and will pull, as its share of the load, the tonnage of the train which is in excess of the maximum continuous tonnage rating of the Diesel locomotive for the grade over which the train is moved. The steam locomotive must be capable of pulling its share of the tonnage without danger of slipping.

Steam locomotives used as helpers often have tonnage ratings based on speeds lower than the continuous rated speed of the Diesel locomotive. Above such speeds, the Diesel locomotive will absorb more than its proportionate share of the load since its tonnage rating is based on the higher speed. As a result, the Diesel locomotive may become overloaded in endeavoring to maintain minimum speed for its continuous rating. This will be indicated by the transition indicating meter pointer moving to the right of the No. 1 green area into the overload area.

Under these conditions, reduce the Diesel locomotive throttle, allowing the train speed to drop and the steam locomotive to pick up its proper share of the tonnage. As the speed decreases, the transition indicating meter

pointer will move to the left. When the pointer reaches the No. 1 green area, the steam locomotive will have assumed enough tonnage to remove the overload from the Diesel locomotive. Operation should be continued at this throttle position.

Should the transition meter be out of order, it will be necessary to handle the throttle by reference to the speed indicator instead of the transition indicating meter. In this case, the table of "Approximate Continuous Speed Ratings" on page 212 should be used. To apply the data in the table, reduce the throttle notch by notch. After each throttle reduction, allow the train speed to become steady and read the speed indicator. Compare the reading with the figure in the table opposite the throttle position being used and in the column corresponding to the gear ratio of the locomotive. If the train: speed is lower than the table figure, reduce the throttle another notch and repeat the procedure, comparing the speed with the line in the table for the new throttle position. Continue the throttle reduction until the train speed becomes equal to or higher than the table speed reading. Continue operation at this throttle position.

		APPROXIMATE CONTINUOUS SPEED RATINGS					
		Miles per hour with 40" wheels					
Throttle		65/12	62/15	61/16	60/17	59/18	58/19
57/20	56/21						
8		11.0	14.5	15.5	17.0	18.0	19.0
20.5	22.0						
7		9.0	11.0	12.0	13.0	14.0	15.0
16.0	17.0						
6		7.0	9.0	10.0	10.5	11.0	12.0
13.0	13.7						
5		5.5	6.5	7.0	7.5	8.5	9.0
9.5	10.0						

An example of the use of the table is given below: Assume the locomotive is one with 62/ 15 gear ratio. When operating in transition No. 1 and throttle Run 8, with a helper locomotive, the train speed drops to 11.0 MPH. This is under the 14.5 MPH shown in the table for a 62/15 gear ratio locomotive in throttle Run 8. The locomotive is overloaded and if the transition indicating meter were working, the pointer would be to the right of the No. 1 green area (700 amperes). The throttle is then reduced to Run 7. The speed drops to 10 MPH and the helper locomotive assumes more load. The locomotive is still overloaded since the table shows 11.0 MPH. The throttle is next moved to Run 6. The speed becomes steady at 9 MPH. This checks with the Continuous Speed Rating in the table and operation should be continued with the throttle in this position.

Operating Without Load and Transition Indicating Meter

If at any time the transition meter does not function properly, or the lead unit has been isolated, it will be necessary to make transition by reference to the locomotive speed. The table below shows the approximate speeds at which transition should occur.

MILES PER HOUR WITH 40" WHEELS
GEAR RATIO

Move Transition
Lever

From Pos.	To Pos.	65/12 57/20	62/15 56/21	61/16	60/17	59/18	58/19
1	2	15	19	21	23	24	26
28	30						
2	3	20	27	29	34	34	36
39	41						
3	4	41	53	59	63	68	73
78	83						
4	3	41	53	59	63	68	73
78	83						
3	2	20	27	29	34	34	36
39	41						
2	1	15	19	21	23	24	26
28	30						
Maximum Permissible Speed		50	65	71	77	83	89
95	102						

Transition should be made in accordance with reading of transition meter and should never be made from speed indicator reading, except when the transition meter fails to function. Handling of Locomotive Under NO condition should the reverse lever be moved while the locomotive is in motion. When the Diesel locomotive is pulling a train either with or without helper service, the handling of the throttle and shifting of the transition lever MUST be in accordance with instructions in this manual. When leaving the locomotive, the reverse lever should be removed from the controller.

If two "A" units are used in making up the locomotive, the reverse lever should always be removed from the controller of the trailing cab.

Operating Over Railroad Crossings

The throttle MUST always be reduced until all power trucks have passed over the crossing. This is to prevent arcing of the brushes on the commutators of the traction motors. If running with the throttle above the 5th position, reduce throttle to 5th position. If running in 4th or 5th position, reduce throttle one position.

Air Braking With Power

In order to keep the train stretched on a rolling grade, it might be necessary to brake the train with power still supplied by the locomotive. In this case, the throttle should be reduced to at least the 6th position. It is very important that the locomotive air brakes be released and kept in the released position when the locomotive is supplying power. This **MUST** be observed.

When preparing to stop with power applied to locomotive and brakes applied to the train, it is necessary to reduce the throttle as the train speed decreases. As the train slows down, the pulling power of the locomotive increases rapidly and might become great enough to part the train if the throttle were not reduced. The throttle should be in "IDLE" at least 100 feet before the locomotive comes to a full stop.

Running Through Water

Under **ABSOLUTELY** no circumstances should the locomotive pass through water which is deep enough to touch the bottom of the traction motor frames. When passing through water, always go at a very slow speed (2 to 3 miles per hour). Water any deeper than 3 inches above the top of the rails is likely to cause damage to the traction motors.

Precautions During Locomotive Operation

- 1. Check engine cooling water temperature. Temperature should be maintained at 165 deg F., plus or minus 15 deg F.

If temperature is not in this range, report this fact at the first maintenance point. Do not attempt to adjust the shutters. For instructions in case of hot engine alarm due to excessive water temperature, refer to "Trouble Shooting," Section 9.

- 2. Lubricating oil pressure should be 35 to 45 pounds (hot oil) at 800 RPM. If main bearing pressure drops below 20 pounds at 800 RPM (hot oil), stop the engine and investigate.
- 3. The fuel sight glasses on the sintered bronze filter assembly should be observed frequently to check supply of fuel to the engine.
- 4. Observe the auxiliary generator ammeters in the electrical control cabinet periodically to see that they are indicating a charge.
- 5. Check traction motor blowers. If a blower is not operating properly, isolate engine until condition is corrected.
- 6. Electric control air pressure should be 80 pounds plus or minus 3 pounds.

Isolating and Stopping Engine While Under Power

If it becomes necessary to take the engine "off the line" while the locomotive is operating under power, it should be done as follows:

- 1. Reduce the speed of the engine to idle with the layshaft manual control lever so that the traction motor contactors will not have to interrupt the full traction motor current.
- 2. Place the isolation switch in the "START" position.
- 3. Press the engine "STOP" button until engine stops.

- 4. Place fuel pump switch in "OFF" position.

If the power plant of the leading unit is isolated while the locomotive is under power, the transition meter will not function; therefore, transition must be determined by the speed indicator according to the figures given under the paragraph "Operating Without Load and Transition Indicating Meter."

Starting and Placing Engine on the Line While Locomotive Is Under Power

- 1. Start engine in the usual way. (See paragraph 4, "Starting Engines After Layover," this section.)
- 2. After lubricating oil pressure builds up, place isolation switch in "RUN" position. If throttle is above 3rd position, hold off on governor to injector linkage with layshaft manual control lever, to allow engine to come up to speed gradually.

Normal Operating Instructions #24 Brake Valve (24-RL Brake Equipment)

A Rotair valve is installed alongside the independent brake valve. There are four positions of this valve indicated in raised letters: Passenger, Passenger-Lap, Freight, and Freight-Lap. If a long freight train is being hauled, this valve should be set in the "Freight" position. This will insure a controlled emergency application. In short freight trains and passenger trains where the controlled emergency feature is not desired, the Rotair valve should be placed in "Passenger" position.

The double-heading cock in the leading "A" unit should be in the "Live" position (handle pointing forward). This valve is situated in the Filling Piece Portion of the #24 brake valve.

The safety control cock situated in the Application Portion of the #24 brake valve should be in the "ON" position, as this will insure operation of all safety devices, deadman foot valve, locomotive overspeed, and train control. This valve may be sealed, if desired.

The equipment includes a controlled release feature. The full release selector cock is located on the left-hand side of the brake valve rotary valve seat. When the cock handle is moved away from the engineer toward the letters MR cast on the cock body, air at main reservoir pressure is supplied to the chamber above the automatic rotary valve as in the No. 6 ET and No. 8 ET equipment. This provides maximum rate of brake pipe recharge when the brake valve is in release position but overcharging is possible. When the selector cock is moved to the FV position (handle pointing toward engineer), air at pressure controlled by a large capacity feed valve is supplied to the same chamber. With the selector cock handle in this position and the automatic brake valve handle in release position, brake pipe recharge is obtained at a rate which represents the maximum that is possible.

A cock located on the right-hand side of the # 24 brake valve, in the Filling Piece Portion, cuts in or out the first service position of the automatic brake handle. Furthermore, if the cock is "in" (handle pointing towards engineer), the time rate of a safety control application is lengthened. If the cock is out (handle pointing towards cab window), the time rate of a train control application is shortened.

At Control Valve In Nose

There are two cocks and one cap in this control valve. The charging changeover cock has a freight and passenger position. When in "Freight" position, charging of pressure chamber is slow; when it is in "Passenger" position,

charging of pressure chamber is fast. The Dead Engine cock will be closed ("Live" position) in normal operation and open ("Dead" position) in case locomotive is being hauled dead in the train. The cap, situated in the rear of the control valve, has two settings, "Graduated" and "Direct." This applies to independent release which will be gradual in passenger trains and direct in freight trains. Locomotive Overspeed Cutout The overspeed control feature can be cut out by closing magnet valve air supply line 3/8" cutout cock on air brake equipment rack.

Deadman Foot Pedal

Should both of the brake valve handles and the deadman foot pedal be placed in the released position when the brakes are released, a service application will result through operation of the safety control feature. On locomotives having the time delay feature, a warning whistle on the brake valve will sound before the application is initiated. If the automatic brake valve handle or the foot pedal is depressed within 4 to 6 seconds, the application will be suppressed. To release a safety control application, depress either the brake valve handle or the foot valve pedal and move the automatic brake valve handle to "LAP" position until the application portion releases and the application pipe gauge shows substantially main reservoir pressure. Then move automatic brake valve handle to "RELEASE", position in the normal manner.

Deadman Cutout

The deadman safety control feature can be cut out by closing 3/a" cutout cock in line from relay air valve unit located on air brake equipment rack.

TOWING LOCOMOTIVE

- 1. Be sure reverse lever is in neutral position. If the locomotive is to be towed in a train any appreciable distance, the reverser drum must be placed in neutral position manually and should be locked in that position. During normal operation, a locking pin is screwed into the lefthand side of the reverser. To lock the reverser drum in neutral, this pin should be removed and inserted in the hole on the opposite side. Turn the drum to its neutral position and the pin will engage with the hole in the shaft.
- 2. The transition lever must be moved to the "OFF" position before the control push-button is pulled out.
- 3. All isolation switches must be in "START" position. If it is necessary to keep engines idling for any reason while towing locomotive, the fuel pump and control switches should be left in the closed position.
- 4. For setting of air brake equipment, see the air brake manufacturer's instruction bulletin.

CHANGING OPERATING ENDS

When the consist of the locomotive includes two "A" units, the following procedure should be followed in changing from one operating end to the opposite end:

- a. Remove reverse lever.
- b. With deadman control pedal depressed, release independent air brake by placing independent brake valve handle in "RELEASE" position.
- c. Make full service automatic brake application.
- d. Close double-heading cock and release deadman control pedal.
- e. Move the Rotair valve to the proper "LAP" position.
- f. Move the automatic brake valve handle to "RUNNING" position and remove the handle from the brake

valve.

- g. Remove the independent brake valve handle in "RELEASE" position.
- h. Open all switches in control push-button box and close the switch lock.
- i. Proceed to cab at opposite end. Check "PC" switch and reset if necessary. Open switch lock on control push-button switch box, close control and fuel pump switches and such other switches as are necessary.
- j. Insert reverse lever, automatic brake valve handle and independent air brake handle.
- k. Move the Rotair valve to the proper operating position.
- l. Move independent brake valve handle to "FULL APPLICATION" position and open the double-heading cock slowly, pausing from 5 to 10 seconds in midposition.
- m. When ready to move locomotive, depress deadman control pedal or automatic brake valve handle and move independent brake valve handle to "RELEASE" position.

Stopping Engine In Preparation For Terminal Layover

- 1. At Engineer's Control Station:
 - a. Close throttle to "IDLE" position.
 - b. Place transition lever in "OFF" position.
 - c. Place reverse lever in "neutral" position and remove lever from controller.
 - d. Open generator field switch. (Do not open control switch, as it is impossible to shut down engines with "STOP" button unless the control push-button switch is closed.)
- 2. At Engine:
 - a. Place isolation switch in "START" position.
 - b. Push engine "STOP" button in and hold it until engine stops.
 - c. Place fuel pump switch in "OFF" position.
 - d. Open cylinder test valves on engine.

NOTE: Engine will not stop with "STOP" button unless electric control air pressure is up (80 lbs.).

LOCOMOTIVE PROTECTIVE DEVICES

Pneumatic Control Switch

The pneumatic control switch is an air-operated electric switch located on the right-hand side of the cab below the window. The purpose of the switch is to reduce the power of the locomotive by bringing the speed of the engines to idle when either of the following air brake applications take place: deadman, train control, locomotive overspeed, or any emergency brake application. The automatic brake valve must be placed in "LAP" position until application pipe air pressure builds up to normal. The switch has a manual reset button which must be pulled out after the brakes have been released. This switch is referred to as the "PC" switch.

When the "PC" switch operates, it opens the fuel pump control circuit on all units, thereby stopping the fuel pumps and de-energizing the master "E" valves in all units, thus reducing the engine speeds to idle and after a short period of time, the engines will starve for fuel and stop. Deenergizing the fuel pump contactors opens the control circuit for the radiator cooling fan motors and the cooling system shutters, causing the fans to stop and the shutters to close.

Engines will stop if "PC" switch opens when the throttle is in 5th or 6th position.

Emergency Operation of "PC" Switch

When the brake pipe is vented at the emergency rate, the piston in the emergency portion of the control valve, moves to the emergency position, thus connecting a pipe to the auxiliary reservoir. This pipe is connected to a double check valve which in turn is connected to the "PC" switch.

Main reservoir pressure operates the "PC" switch when any application is made from the "M" application valve.

When the "PC" switch is operated from the emergency portion of the control valve, auxiliary reservoir pressure is used. (Auxiliary reservoir is normally charged to feed valve pressure.)

The "PC" switch is set to operate, or trip, at 40 pounds air pressure and reset at 20 pounds.

Operation of Wheel Slip Indicator

Whenever one pair of wheels slips on one or more trucks of the locomotive, the wheel slip indicator on the engineer's instrument panel will light. To stop the slippage, ease off on the throttle one or more positions. After the wheels stop slipping, indicated by the light going out and staying out, the throttle may be opened to the desired position.

The light will not burn continuously when wheels slip, because the wheels will not slip continuously. The connections of the wheel slip relay to the power plant are such that the power is automatically reduced when the wheels slip. Therefore, the wheels will slip, then stop, slip again and stop-about once a second.

When there is a wheel slip indication, it will probably be only one set of wheels that is slipping, unless the rail conditions are extremely bad. On these locomotives with many traction motors, all of which exert their tractive effort independently, with the connections as outlined above, a wheel slip indication usually means only a partial and temporary loss of tractive effort.

It is, therefore, unnecessary to use sand except under the worst track conditions. Before applying sand, be sure to reduce the throttle until the wheel slip light stops flashing. It should be remembered that sand is injurious to the traction motors and associated equipment.

If one pair of wheels is locked, due to a broken pinion or axle gear, or the armature shaft frozen in its bearings, the wheel slip signal will light and will stay on as long as current is being supplied to the motors. This is true except in the case of very low locomotive speeds due to the fact that a definite difference in potential between the traction motors is required to make the wheel slip relay function with the motor circuit in the series-parallel or parallel positions. Therefore, the locomotive speed must be great enough to bring about this difference in potential for any wheel slip indication to be given.

During transition from series-parallel-shunt to parallel, the wheel slip relay will pick up, causing the wheel slip light to flash. This is not an indication that the wheels are slipping.

The wheel slip relay will give wheel slip indication for both series-parallel and parallel operation.

Low Oil Pressure Alarm Switch

This switch is connected to the engine lubricating oil system at the blower oil supply line in such a manner that failure of the lubricating oil pressure will cause the switch contacts to open. When these contacts open, the master "E" magnet valve will be deenergized, shutting off the air supply to the electro-pneumatic governor control, and bring the engine to idle; the low oil pressure signal lights will light and the alarm bells will ring in all units. Should this occur, do not attempt to load the engine until the cause of the low oil pressure has been located and corrected. This alarm switch will not give low oil pressure protection when the isolation switch is in "START" position.

Lube Oil Suction Alarm Switch

The lube oil suction alarm switch is a vacuum switch connected to the suction side of the lube oil and piston cooling oil pumps, and electrically connected to the master "E" valve and the low oil pressure signal alarm circuits in all units. The purpose of this switch is to reduce the engine speed and at the same time to energize the low oil pressure signal alarm circuit should the oil pump suction reach the value at which the switch is set to operate. Excessive oil pump suction is the result of clogged suction strainers.

Operation of this switch will most commonly occur at full engine speed as the pump suction increases with engine speed. The switch will then open the master "E" valve circuit and close the low oil pressure signal alarm circuit. However, as the engine speed decreases, due to de-energizing the "E" valve, the pump suction will also decrease, allowing the suction switch to reset, thus re-energizing the "E" valve and opening the low oil pressure signal alarm circuit. The engine will then speed up until the pump suction again becomes excessive, and the cycle will repeat. If this occurs, the engine should be isolated and no attempt made to load it until the cause of the lube oil suction alarm is located and corrected.

Engine Overspeed Trip

This is a flyweight on the engine camshaft which operates small cams under each injector rocker arm to raise the rocker arm cam followers off the camshaft cam, thus preventing injection of fuel. The trip operates at approximately 880 RPM of the engine. The overspeed trip may be caused to operate by a sudden loss of electrical load, such as wheel slippage or ground relay tripping.

The overspeed trip resetting lever is located on the front end of the engine directly behind the engine governor. If trip operates, it can be reset by turning lever in a counter-clockwise direction until it latches.

Engine High Temperature Alarm Switch

This is a thermal switch located alongside the engine control and instrument panel, which connects with one thermal element in the water outlet manifold of the engine. If the water temperature exceeds 208° F., this switch closes, lights the hot engine alarm signal light, and energizes the signal relay, which rings the alarm bell. The tube leading from the element to the switch must not be kinked or dented.

No A.C. Voltage Alarm

A "No A.C. Voltage" relay is connected across one phase of the A.C. alternator. At 275 RPM this relay will pick

up and will remain energized until voltage drops below a predetermined setting. When it drops out, it will ring the alarm bell in all units, light a blue light in the unit affected, and reduce engine to idle speed. This relay will be deenergized whenever the voltage drops due to failure of the alternator field excitation, which is supplied by the auxiliary generator. The "No A.C. Voltage" alarm will not operate when the isolation switch is in "START" position.

Since the traction motors are cooled by four A.C. induction motor blowers, failure of the alternating current will result is burned or badly damaged traction motors, if power continues to be applied.

Locomotive Overspeed

When the maximum recommended locomotive speed has been exceeded, a magnet valve becomes de-energized through the opening of a micro-switch in the speed recorder, thus venting the pipe connected to the upper portion of the "M" application valve, causing the application piston to move upward, connecting the main air reservoir pressure to the "PC" switch, and opening the "PC" switch.

Ground Protective Relay

If a ground occurs in the high voltage system, the ground protective relay in the electrical control cabinet will open the battery shunt field contactor and bring the engine to idle by de-energizing the master "E" valve. Should this occur, isolate the engine and reset the relay by manually pressing the reset lever to the left. When the relay is tripped, the white needle will point to the red indicator, and to the yellow indicator when in normal position. Place the engine back on the line and if the relay repeatedly opens when the engine speed is increased, the power plant **MUST** be isolated.

A knife switch in the electrical control cabinet renders the ground protective relay inoperative when opened. This switch is provided for use during certain electrical tests during maintenance operations. It should not be opened on the road except under circumstances authorized by definite instructions of the particular railroad on which the locomotive is operating.

A ground in the low voltage system will also trip the relay when an engine is being started. Engines will stop if relay opens when throttle is in 5th or 6th position.

Thermal Overload Protective Device

Each cooling fan motor contactor contains a protective device to prevent overload current in the fan motor operating circuit. In case of such an overload, a thermal element melts and allows a ratchet device to open the contactor operating circuit and stop the fan motor. If this should occur, allow a few minutes for the alloy to cool and solidify before pushing "in" on the reset button. If a contactor trips the second time within a short interval, do not attempt to reset it. This should be reported at the first maintenance point.

ELECTRO-MOTIVE DIVISION
SECTION F2-3-1

• GENERAL MOTORS CORPORATION
COOLING

SECTION 3

COOLING SYSTEM

Description

The cooling systems of the various engines in the freight locomotives are independent of each other. They are similar in every respect except that the "A" units have cab heaters.

Four direct motor driven cooling fans are mounted in the main hatch above the engine. The fan motors are electrically connected to the D-14 alternator through four contactors located in the electrical control cabinet, each contactor serving one fan motor. These contactors are operated by the thermostat switch located in the outlet elbow of the right-hand radiator bank. The automatic shutters are operated by two air cylinders located one on each side of the locomotive.

The cooling system is designed so that the water level is below the radiators when the engine is shut down. Freezing of radiators is thereby prevented during cold weather when the system is heated by steam. Operating the system at this level has the following additional advantages:

- 1. Eliminates expansion overflow and loss of radiator compound during operation. (Amount of expansion is approximately 15 gallons.)
- 2. Permits visual indication of loss of water by means of the water level gauge glasses.

Distilled water should be used in the cooling system to offset the accumulation of scale and foreign matter, which contributes to overheating the engine.

Operation of Cooling Water System

Water is drawn from the oil cooler and water tank assembly by centrifugal water pumps located on the front end of the engine. These pumps circulate the water to the bottom of each cylinder liner, up through the cored passages of the cylinder liner and cylinder head, and out through the outlet manifold. From the engine, the water flows to two banks of radiator sections located in the main hatch over the engine. Here the water is cooled, returning through the oil cooler assembly to the engine. See Fig. 3-3 in Section 3 of this manual for description of the oil cooler and water tank assembly.

The radiators are cooled by four A.C. motor driven fans which receive their current from the alternator which is built into the main generator. The automatic temperature control is arranged so that the fan motors do not operate until after the shutters are opened at approximately 166 deg F. The fan motors are then automatically started consecutively at 169 deg F. according to cooling demands until all fan motors are operating at 178 deg F. All fans are cut out and shutters are closed when the engine water temperature drops to 163 deg F. The fan speed varies directly with the engine speed and is so proportioned that the fans rotate at 1250 RPM when the engine is turning at 800 RPM. The number of fan motors actually in operation depends upon the cooling demands, due to weather conditions and load imposed on the engine. Operation of the transfer relays controls the sequence in which the fans cut in. See "Transfer Relays," Section 6.

A water temperature gauge is located in the suction line to a water pump and indicates the water temperature into the engine. The automatic control is operated from the water "out" temperature, so the temperature indicated on the gauge may be as much as 12 deg below the above temperatures at full load. This gauge has a color-coded dial with black lines indicating the 120 deg F. and 190 deg F. points. Below 120 deg F. the dial is colored blue, from 120 deg F. to 190 deg F. green, from 190 deg F. to 200 deg F. yellow merging into red, and full red above approximately 200 deg F. The normal operating range is indicated by a wide area of the green section. Operation outside of this wide green section should be investigated immediately for cause.

The temperature switches that control the automatic shutters are adjusted at the maintenance terminal to open and close at the correct temperatures and should NOT be changed by any unauthorized person.

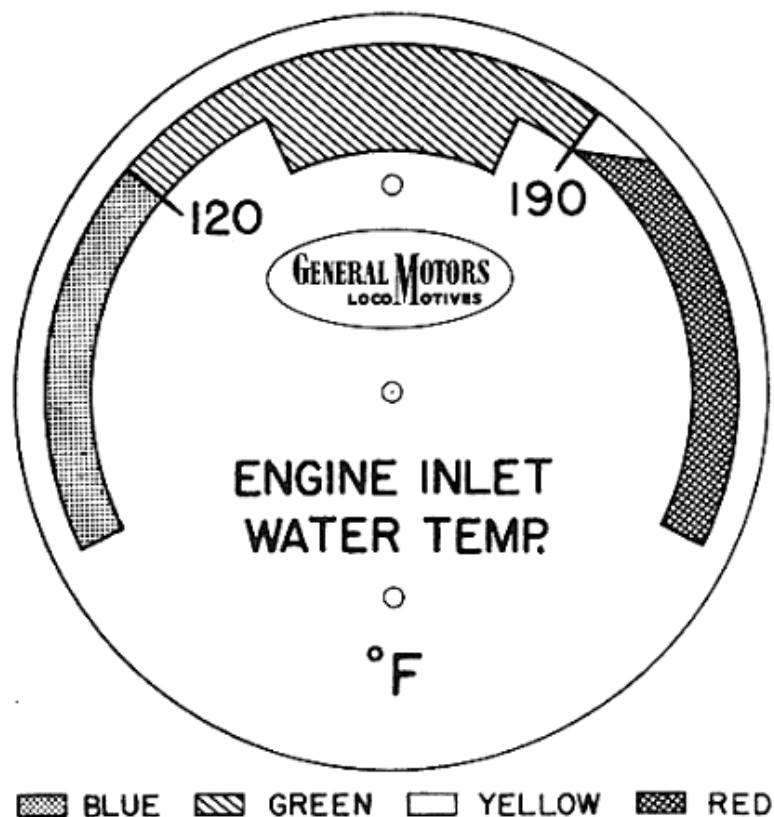

Water Temperature Gauge
Fig. 3-1

Filling the Cooling System

The system is filled either through the filler pipe located on the roof of the locomotive above the water tank, or through the filler pipe at the rear of the unit on either side. To fill the system, proceed as follows:

- 1. Open filling level valve "G" (Fig. 3-3).
- 2. Fill slowly until water runs out filling level pipe at valve "G."
- 3. Close filling level valve "G."
- 4. Start engine and run for several minutes. This will eliminate any air pockets in the system.
- 5. Shut down engine and open valve "G," and wait 3 minutes.
- 6. Add water until it runs out filling level pipe.
- 7. Close filling level valve "G."

If the cooling system of a hot engine has been drained, do not refill immediately with cold water. If this is done, the sudden change in temperature might crack or warp the cylinder liners and heads.

CAUTION:

- 1. Do not attempt to fill the cooling system through the drain pipe located underneath the locomotive.
- 2. The system should not be filled above the maximum water level indicated on the water tank.

Operating Water Level

There are two 16" water gauge glasses located on the water tank above the engine control and instrument panel. These are so arranged that the glasses overlap and provide full operating water level coverage. The "G" valve is located above and to the rear of the left rear engine room door. The water level should never be above this point with the engine shut down. The drain from this valve passes through a funnel for easy visibility.

Operating water levels are stencilled on the water tank next to the water gauge glasses to indicate proper operating levels. Capacity of a "B" unit cooling system is 220 gallons to the maximum level mark and 183 gallons to the minimum level and an "A" unit holds approximately 15 gallons more, due to the inclusion of cab heaters and related piping.

Adding Water to the System

When it is necessary to add water to the cooling system proceed as follows:

- 1. Shut down engine.
- 2. Add water slowly until it runs out filling level pipe.
- 3. Close valve "G." The engine should never be operated with the water below the low water level. Progressive lowering of water in the gauge glasses indicates a leak in the cooling system.

CAUTION: As specially treated water must be used in the cooling system, no water should be added except at an approved watering station. Abnormal use of cooling system water, or absence of corrosion inhibitor, as indicated by lack of color, should be noted in the locomotive log and reported at the first maintenance point.

Engine High Temperature Alarm Switch

This is a thermal switch located alongside the engine control and instrument panel, which connects with one thermal element in the water outlet manifold of the engine. If the water temperature exceeds 208 ° F., this switch closes, lights the hot engine alarm signal light, and energizes the signal relay, which rings the alarm bell. The tube leading from the element to the switch must not be kinked or dented.

If Hot Engine Alarm Sounds

- 1. Check engine temperature gauges to determine which engine is causing alarm.
- 2. Take engine "off the line."
- 3. Check for cause-inoperative shutters, fans not running, low water, defective water circulating pump, or restricted circulation.

Checking Circulation

The water temperature dial gauge located in the water pump inlet elbow may be used as a means of detecting an irregularity in the operation of the cooling system. High water temperatures indicate:

- 1. Fans not operating.
- 2. Shutters not operating properly.
- 3. Insufficient water in cooling system.
- 4. Faulty circulation.

Draining the Cooling System

The engine water drain is located on the center line of the locomotive at the accessory end of the engine. Drainage from this valve spills into a funnel in the floor of the locomotive and is piped to the left side of the underframe, forward of the No. 2 bolster. This drain will empty the water tank, oil cooler, radiators, and all of the engine except the bottom of the right bank water pump scroll. Removal of the bottom pipe plug will drain this scroll. Should it be necessary to drain the cab heaters on "A" unit, see Fig. 3-2. The following steps should be taken:

- 1. Open cab heater valve (3) located above the steps leading into the cab.
- 2. Open the cab heater drain valve (9) located behind the No. 2 sand box on the left side of the locomotive. When this valve drains completely then open the cab heater steam valves (2) at each cab heater.
- 3. Open the steam line drain valve (4) on the right side of the engine room at the foot of the steps leading to the cab.

Flushing the Cooling System

Complete instructions for flushing the cooling system are outlined in Maintenance Instruction 1706.

Freezing Weather Precautions

Do not use any kind of anti-freeze solution in the cooling system. If locomotive is to be left standing where there is danger of freezing, steam may be supplied to the cooling system, or the system can be drained. Should it be desired to steam heat the cooling system when the engine is not running, the following steps should be taken:

- 1. Open the "G" valve.
- 2. Open the steam admission valve (Fig. 3-3) located at the right rear of the engine. On "A" unit (see Fig. 3-3), the following additional valves must be opened (Fig. 3-2):
 - a. Open the cab heater valve (3) above the left side steps leading into the cab.
 - b. Open the steam admission valve (7) at the foot of the right side steps leading into the cab.
 - c. Open the steam valves (2) at each heater.
- 3. Make certain steam trainline valves are open (if external source of steam is used).

Cab Temperature Control

The temperature of the cab can be controlled by valve (3) on Fig. 3-2, and a three-speed switch controlling the fan motor on each of the two cab heaters. The cab heaters operate on hot water from the engine cooling system and are equipped with a motor driven fan for maximum radiation.

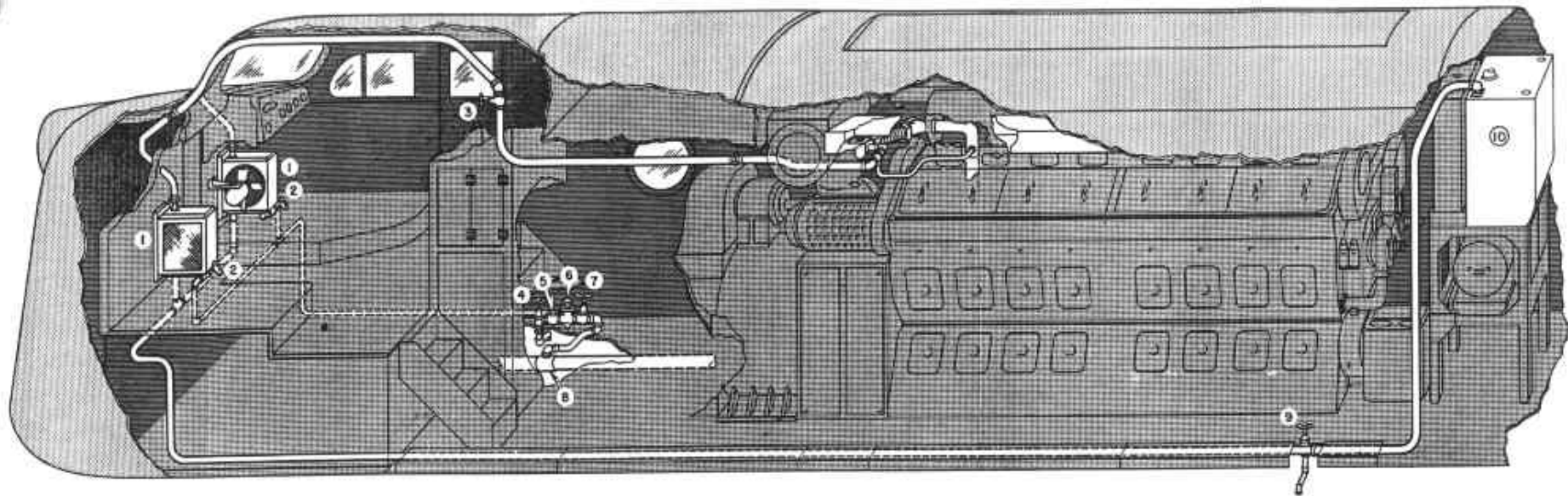

- 1. Cab Heaters.
- 2. Cab Heater Steam Valves.
- 3. Cab Heater Valve.

- 4. Steam Heating Line Drain Valve.
- 5. Check Valve.
- 6. Steam Pressure Reducing Valve.
- 7. Steam Admission Valve.

- 8. Steam Trainline Connection.
- 9. Cab Heater Drain Valve.
- 10. Engine Cooling Water Tank.

Cab Heating System -- Fig. 3-2

- 1. Water Pump
- 2. Lubricating Oil Pump
- 3. Scavenging Oil Pump
- 4. Sump Oil Strainer
- 5. Lube Oil Strainers
- 6. Lube Oil Filter
- 7. Lube Oil Relief Valves
- 8. Lube Oil Cooler
- 9. Cooling Water

Tank
 10. Water
 Level
 Gauges
 11. "G"
 Valve
 12. Roof
 Filler
 13. Low
 Oil
 Pressure
 Alarm
 Switch
 14. Lube
 Oil
 Suction
 Alarm
 Switch
 15.
 Cooling
 Fans
 16.
 Radiator
 17.
 Thermostat
 Switch
 18. To
 Cab
 Heater
 19.
 Cylinder
 Liner
 20. Engine
 Sump
 21. Side
 Filler
 22. Drains
 23. Steam
 Admission
 Line
 24.
 Bayonet
 Gauge

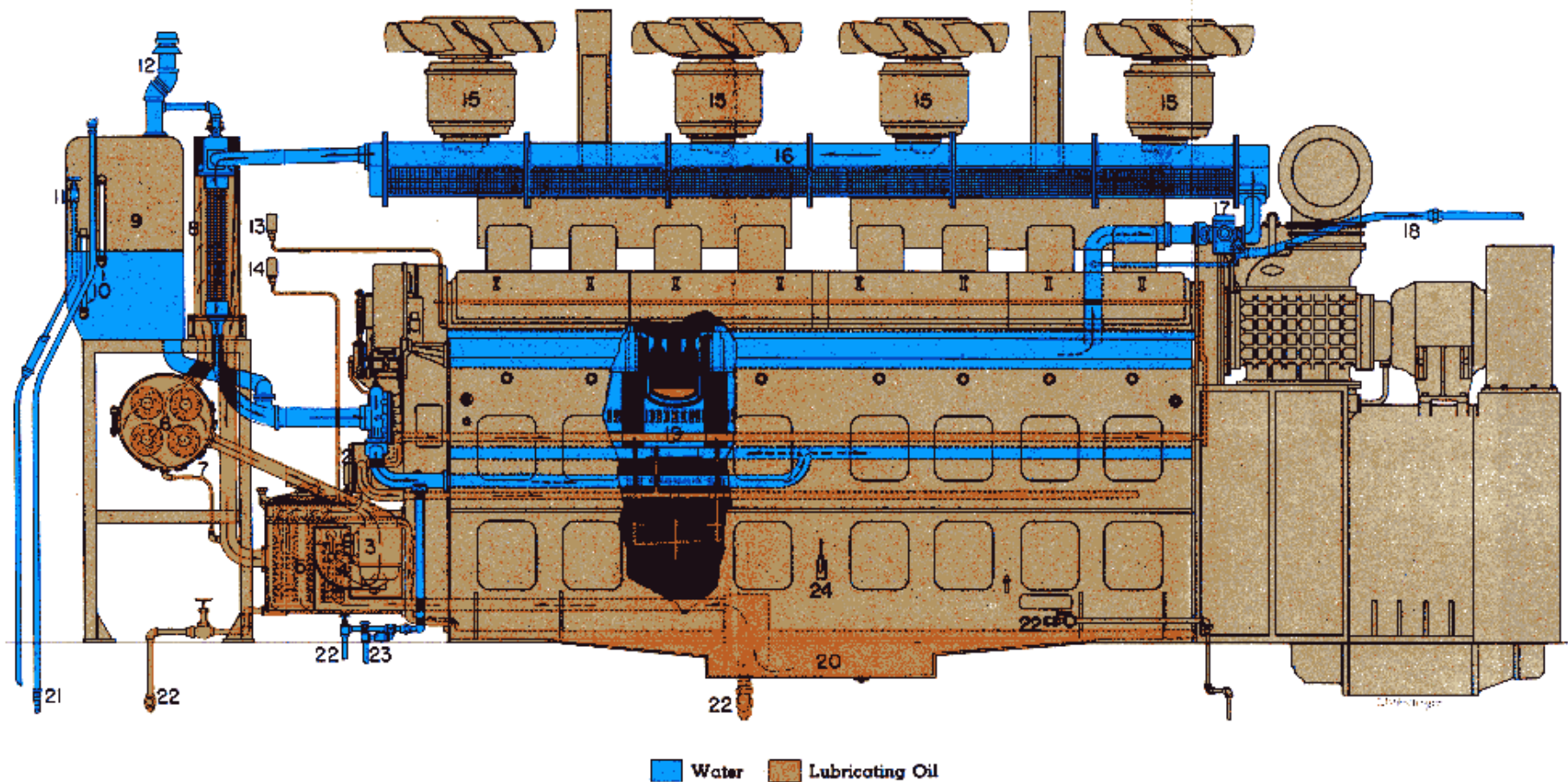

Schematic of Cooling and Lube Oil Systems
Fig. 3-3

ELECTRO-MOTIVE DIVISION
SECTION F2-4-1

GENERAL MOTORS CORPORATION
LUBE OIL

SECTION 4

LUBRICATING OIL SYSTEM

The lubricating oil systems of the various engines throughout the locomotive are identical to and independent of each other. The oil is stored in the oil pan of the engine, instead of an oil supply tank, which classifies the engine as a wet sump type.

Description

The engine lubricating oil system is a pressure system using two positive displacement gear type pumps combined in a single unit. One pump delivers oil for the pressure lubricating system, the other for piston cooling. The oil supply to these pumps is drawn from the oil strainer chamber through a common suction pipe.

A scavenging oil pump is used to draw oil from the engine oil pan through a strainer, pump it through the lube oil filter to the cooler core section of the oil cooler tank and return it to the strainer chamber. See Fig. 3-3.

Operation

When the engine is started, the pressure pumps pick up oil from the bottom of the strainer chamber. This oil provides an initial supply for lubricating the engine until the scavenging pump has refilled the strainer chamber. Until the scavenging oil reaches the strainer chamber, the pressure may read low on the engine control and instrument panel gauge.

A baffle plate or "dam" tends to maintain the oil level in the cooler core chamber. This oil level will vary depending on engine speed. Oil flowing over this dam returns to the strainer chamber and then overflows into the engine oil pan, keeping the scavenging pump suction pipe under oil. If the oil is too cold and heavy or if the Michiana filters are dirty, the relief valves located in the filter housing will open to by-pass the oil past the filters. If the oil is too cold or heavy or if the cooler core is dirty, the oil will flow over the cooler core into the strainer chamber to keep the pressure pumps supplied.

With the engine running the oil level should always be between the "LOW" and "FULL" marks on the bayonet gauge in the engine oil pan. The oil level can be checked with the engine running at any speed.

Adding Oil to System

When oil is added to the system, it must be poured through the opening having the square cap on top of the strainer housing. Should the round caps be removed while the engine is running, hot oil under pressure will come from the openings and possibly cause personal injury. When the engine is stopped, oil added through one of the round openings will not be properly filtered before entering the oil pan. Therefore, never attempt to add oil through either of the round openings, whether the engine is running or stopped. See Fig. 3-3.

When the engine is stopped, all the oil in the cooler core chamber will drain into the strainer chamber and then overflow into the engine oil pan, which will bring the engine oil pan bayonet gauge reading to "system charged." This level is below the "system uncharged" level because some oil is trapped in the lube oil filter, oil lines and engine.

Main Bearing Lubricating Oil Pressure

Lubricating oil pressure must be maintained at all times. When starting a cold engine, allow it to idle for some time and see that pressure starts to build up almost immediately. The pressure should rise on a cold engine to about 50 pounds and will run approximately 35 to 45 pounds at 800 RPM with engine warm. At idle, pressure should be at least 6 pounds.

With normal operation, the lubricating oil pressure should not drop below 20 pounds, with engine running at 800 RPM.

However, if the water temperature cannot be held below 180 deg F., it will be permissible to operate the engine with lubricating oil pressure, at the rear end of engine, as low as 15 pounds.

This low limit on pressure can only be permitted when the oil temperature is high as a result of the water temperature being above 180 deg F.

If lubricating oil pressure drops below the above limits, stop the engine and investigate cause.

Low Oil Pressure Alarm Switch

This switch is connected to the engine lubricating oil system at the blower oil supply line in such a manner that failure of the lubricating oil pressure will cause the switch contacts to open. When these contacts open, the master "E" valve will be de-energized, bringing the engine to idle, the low oil pressure signal lights will light and alarm bells will ring in all units. Should this occur, do not attempt to load engine until the cause of the low oil pressure has been located and corrected. This alarm switch will not give low oil pressure protection when the isolation switch is in "START" position.

Should an engine stop for any reason, the oil pressure will drop to zero and the low oil pressure alarm will operate. The alarm thus serves to indicate immediately an engine stoppage in any unit.

Lube Oil Suction Gauge and Alarm Switch

The lube oil suction gauge is mounted on the engine control and instrument panel which will indicate high

pump suction caused by clogged lubricating oil strainers in the strainer chamber. The color-coded dial is marked off in green, yellow and red blocks. Under normal conditions the needle of the gauge should be within the green portion of the dial. If the oil strainers become partially clogged, the needle will advance to the yellow portion of the dial. If the strainers become clogged to the extent that the pump suction reaches the value at which the suction alarm switch is set to operate, the engine speed will be reduced as explained in the following paragraphs. If this should occur, the needle will be in the red portion of the gauge dial.

The lube oil suction alarm switch is a vacuum switch connected to the suction side of the lube oil and piston cooling oil pumps, and electrically connected to the master "E" valve and the low oil pressure signal alarm circuits. The purpose of this switch is to reduce the engine speed and to energize the low oil pressure signal alarm circuit in all units if the oil pump suction reaches the value at which the switch is set to operate.

Operation of this switch will most commonly occur at full engine speed because the pump suction increases with engine speed. The switch will then open the master "E" valve circuit and close the low oil pressure signal alarm circuit. However, as the engine speed decreases, due to de-energizing the "E" valve, the pump suction will also decrease, allowing the suction switch to reset, thus reenergizing the "E" valve and opening the low oil pressure signal alarm circuit. The engine will then speed up until the pump suction again becomes excessive and the cycle will repeat. If this occurs, the engine should be isolated and no attempt made to load it until the cause of the lube oil suction alarm is located and corrected.

Oil Separator

The oil separator is mounted between the engine scavenging air blowers over the main generator. Vapor from the oil pan and gear train housing is drawn through the oil separator to the blower intake. The metal screen in the separator condenses oil from the vapor and returns the oil to the engine oil pan.

Possible Lubrication Troubles

Absence of Oil in Oil Strainer Chamber. This may be caused by an inoperative scavenging system or an open drain valve. Failure of scavenging system may be due to a broken or loose oil line connection causing an air leak, a faulty scavenging oil pump, or clogged suction strainers.

Low Lubricating Oil Pressure. This may be due to stuck relief valve, broken oil lines, clogged strainers, excessive bearing wear, low oil viscosity, faulty pump, or diluted oil.

Failure of the Oil Pump. This may be due to a sheared shaft, broken housing, or damaged gears. If relief valve sticks open, inspect for dirt lodged on seat.

Dilution. It is possible for fuel oil to get into the lubricating oil if an injector is defective, or if a fuel oil line connecting the injector to the fuel oil manifold should become loose or broken. If such a condition has existed, the viscosity of the lubricating oil should be checked.

On the road, dilution may be indicated by gradual rise of the engine oil level during operation of the locomotive. The oil pressure will also fall and read lower than normal. When such conditions are noted, they should be reported for investigation at the maintenance point.

Excessive Oil Consumption. This may be caused by an oil leak, broken or stuck piston rings, worn cylinder liners, damaged blower oil seals, dirty or clogged oil separator screen, improper grade of oil, excessive oil pressure, or clogged drain holes in pistons under the oil control piston rings. Cause should be investigated and corrected.

Little or No Oil Consumption. This may be due to water or fuel leaking into the oil, or to the use of too heavy an oil. Cause should be investigated and corrected.

ELECTRO-MOTIVE DIVISION
SECTION F2-5-1

• GENERAL MOTORS CORPORATION
FUEL OIL

SECTION 5

FUEL OIL SYSTEM

Description

The fuel systems of the engines in the locomotive are independent of and identical to each other. A fuel tank is mounted under each unit of the locomotive. At the bottom of the tank are two sumps, the tank sump and the supply sump, which are connected through an emergency fuel cutoff valve. The fuel pump draws fuel oil from the supply sump through a suction line and suction filter. Fuel can only be drawn from the supply sump if the emergency cutoff valve is open. After leaving the pump, fuel is pumped through the sintered bronze filter assembly to the injectors. The injectors use only a part of the fuel pumped through them. The surplus fuel oil lubricates and cools the internal mechanism of the injectors and then returns to the fuel tank through an orifice and sight glass. See Fig. 5-1.

The use of the correct grade of fuel oil is of the utmost importance. For details of injectors and fuel oil specifications, refer to the Engine Maintenance Manual.

Filling Fuel Tanks

The fuel tanks can be filled from either side of the locomotive at a maximum rate of 250 gallons per minute. Watch the tank level gauge at the filler casting to prevent overflowing the tank. The fuel should be filtered through a reliable fuel filter before it enters the tank. The fuel capacity of each tank is 1200 gallons. Do not handle fuel oil near an open flame.

>Draining Fuel Tanks

The fuel tank sump has two drain plugs for draining the tank and two special drilled plugs for draining any water which may have settled in the tank sump. By turning one of these plugs part way out, water can be drained from the sump. See Fig. 5-1.

Locomotive fuel tank sumps and the fuel storage tanks should be drained periodically to prevent excessive accumulation of water. The drain plug should be removed from the supply sump occasionally for draining sediment.

During freezing weather it is good practice to put about 5 gallons of alcohol in the locomotive fuel tank. The alcohol will settle in the tank sump and prevent the water from freezing. If conditions warrant, it is advisable to add alcohol to the fuel storage tanks.

Fuel Tank Vents

Two vents, one on each side, with 4-inch flame arrestors, terminate outside the locomotive unit.

Emergency Fuel Cutoff Valve

In the event of fire, an emergency fuel cutoff valve is provided to cut off the fuel supply to the fuel pump. The valve is located in the feed line between the fuel tank sump and the

supply sump.

On each side of the locomotive, attached to the side skirt, is a small box with a lift cover. Enclosed in this box is a pull-ring on the end of the cable running to the emergency fuel cutoff valve. A similar ring is located in each cab. The valve can be closed, and the fuel cut off, by pulling any one of these three rings. If closed, the valve underneath the fuel tank must be reset manually to the "open position.

Fuel Gauge

The fuel gauge is a direct reading, air-operated gauge which indicates the quantity of oil in the fuel tank. The gauge is located in the engine room on the engine control and instrument panel.

Fuel Level Gauge

A direct leading sight level gauge is located on each side of the fuel tank adjoining the fuel fillers. This gauge indicates level of fuel oil starting at 4 1/2 inches from the top of the tank and should be observed while filling the tank to prevent overflowing.

Fuel Pump

The fuel pump assembly consists of an electric motor and a pump of the rotor gear type. The gear pump is driven by the motor shaft through a flexible coupling. Do not leave the fuel pump running unnecessarily.

Pump Suction Filter

The fuel oil drawn from the supply sump passes through the suction filter to remove any foreign material that might damage the fuel pump.

Sintered Bronze Fuel Filter Assembly

This fuel filter consists of two sintered bronze elements, an orifice and sight glass, and a 60-pound relief valve and sight glass. It is mounted on the right front end of the engine.

The fuel being pumped to the engine passes through both filter elements to the fuel manifold on the engine. As the fuel enters the injector, it is filtered for the third time by a small filter mounted in the injector body. The purpose of all this filtering is to protect the finely machined parts of the injector.

As the surplus fuel leaves the injector, it passes through the fuel outlet filter in the injector body which prevents a reverse flow of fuel from carrying dirt into the injector when the engine is shut down. These filters should be discarded when dirty, and new ones installed.

The fuel oil then passes through the 5-pound sight glass (sight glass nearest to engine), returning to the fuel oil tank. The orifice retards the flow of fuel from the injectors so that approximately a 5-pound head is maintained at the injectors. A drop in fuel level in this glass, or an empty glass, will indicate that the engine is not receiving its full supply of fuel. Air entering the fuel line at any point on the suction side of the fuel pump will cause the engine to misfire or stop. Air or gas in the fuel system will appear in this glass in the form of bubbles. The presence of bubbles, with the engine shut down and fuel pump running, indicates an air leak in the suction line. If bubbles appear only when the engine is running, an injector is allowing gas to escape from an engine cylinder into the fuel line.

The 60-pound sight glass will show fuel by-passing when the sintered bronze filters collect enough dirt to build up a back pressure of 60 pounds. Should this occur, the relief valve will open and the fuel will by-pass the filters and engine and return to the fuel tank. No attempt should be made to run the engine until the filters have been cleaned or changed.

Injector

For information on injectors, refer to Engine Maintenance Manual.

Fuel Failure

If fuel pump is running but fuel does not show in the 5pound sight glass, check the following:

- 1. Supply of fuel in the tank.
- 2. Emergency fuel cutoff valve.
- 3. Broken motor or pump shaft, or loose flexible coupling.
- 4. Loose, broken, or clogged supply line.
- 5. Dirt lodged under the 60 pound relief valve seat.
- 6. Defective pump.
- 7. Check suction filter gasket for air leakage.
- 8. Dirty suction filter.

If electric motor is not running, check the following:

- 1. Fuel pump motor fuses.
- 2. Fuel pump switch.
- 3. Main battery switch.
- 4. Contactor behind the engine control and instrument panel.
- 5. Electrical connection at motor.
- 6. Fuel pump motor brushes.

- | | |
|---|--|
| <ul style="list-style-type: none"> ● 1. Engine Control and Instrument Panel ● 2. Suction Filter ● 3. Fuel Pump and Motor ● 4. Sintered Bronze Filter and Sight Glass Assembly ● 5. Injector ● 6. Steam Generator Fuel Supply ● 7. Steam Generator Fuel Return ● 8. Fuel Supply to | |
|---|--|

- Engine
- 9. Fuel Return from Engine
- 10. Emergency Fuel Cutoff Pull Ring
- 11. Fuel Filter
- 12. Sight Gauge
- 13. Vent and Flame Arrester
- 14. Fuel Tank
- 15. Fuel Supply Sump
- 16. Sump Drain Plug
- 17. Emergency Fuel Cutoff Valve
- 18. Fuel Drain Plug
- 18. Fuel Tank Sump
- 20. Fuel Tank Water Drain Plug

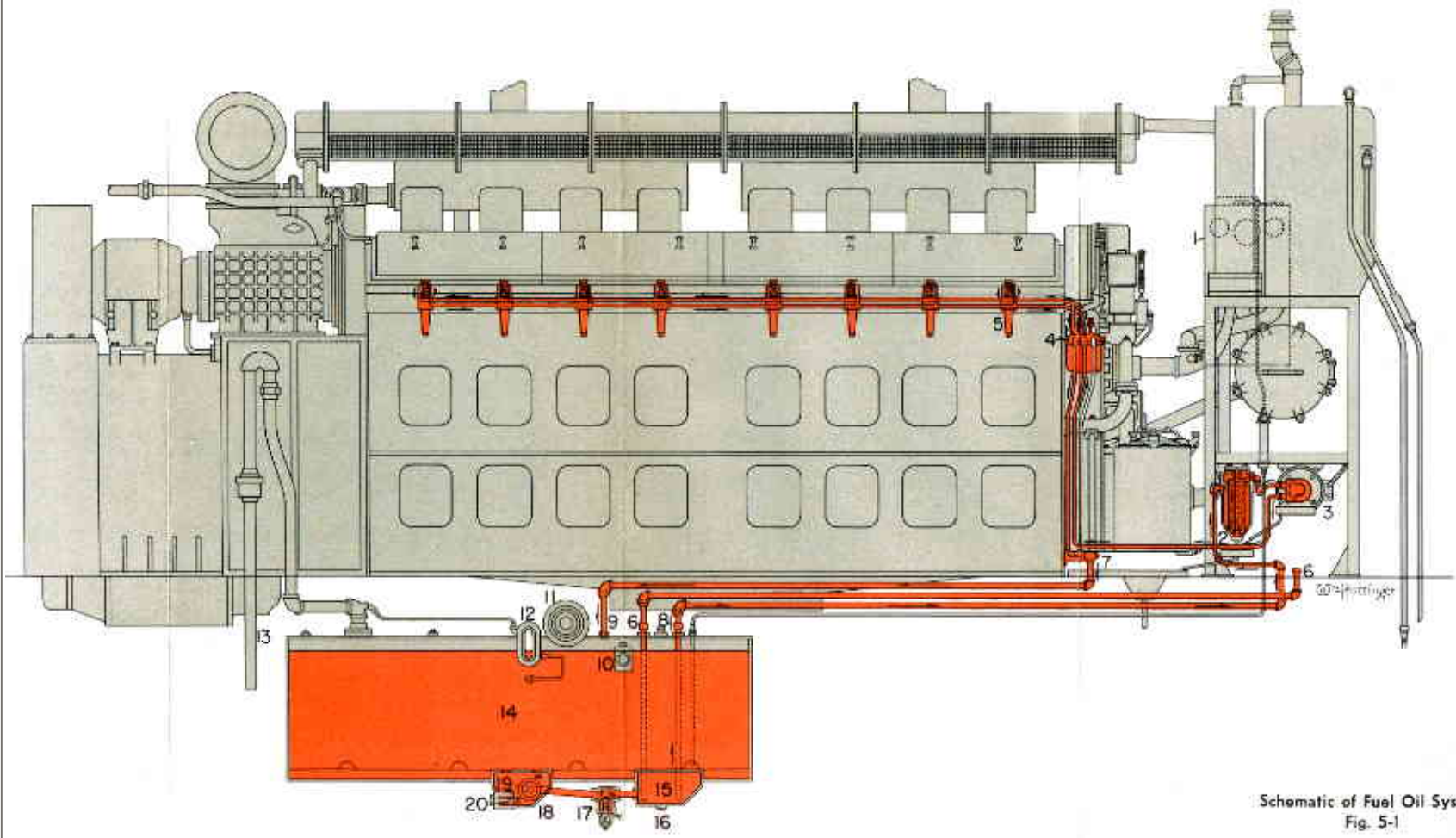

Schematic of Fuel Oil System
Fig. 5-1

Schematic of Fuel Oil System
Fig. 5-1

ELECTRO-MOTIVE DIVISION
SECTION F2-6-1

GENERAL MOTORS CORPORATION
ELECTRICAL

SECTION 6

ELECTRICAL EQUIPMENT

This section deals with the description and function of electrical equipment on the locomotive. A Standard Schematic Wiring Diagram of the "A" unit will be found in this section.

The following is an index to items covered in this section:

ITEM	PAGE
Alternator	601
Ammeter	616
Contactors	603-606
Controller (Control Stand)	601
Distribution Panel	614-615
Generators	600-601
Electrical Control Cabinet	613-615
Load Regulator	616
Magnet Valves	617
Motors	602-603
Pilot Valve	616
Relays	606-609
Resistors	612-613
Reverser	601
Speed Recorder	616
Switches	609-612
Traction Motor Control Circuit Explanation	617-619
Voltage Regulator	606

Main Generator

The main generator is directly connected to the Diesel engine through a flexible coupling. The generator produces direct current for operating the traction motors. A selfaligning bearing in the commutator end housing carries the weight of the commutator end of the generator armature. The other end of the armature is supported

by the engine crankshaft rear main bearing. The generator is cooled by a blower mounted on the generator and coupled on the end of the auxiliary generator shaft.

Alternator

The alternator is built into the engine end of the main generator and supplies A.C. power for the traction motor blowers and the radiator cooling fan motors.

Auxiliary Generator

The auxiliary generator is used for charging the locomotive storage batteries and to supply all the low voltage D. C. power when the locomotive is operating. This generator is direct drive through flexible couplings from the rear gear train of the engine. The voltage output of the auxiliary generator is maintained at a constant level of 74 volts by the voltage regulator.

Controller

The controller (or control stand) contains the throttle lever, reverse lever, and transition lever. The throttle lever, by means of electric contacts, operates the electro-pneumatic governor controls, which controls the speed of the Diesel engines through the engine governors. The reverse lever operates electric contacts which close a circuit energizing either the "forward" or "reverse" magnet valves on the reversers in the electrical control cabinets. There is no mechanical connection between the reverse lever and the reverser. The transition lever, through electric contacts, changes the traction motor circuits to obtain the desired locomotive tractive effort and speed.

Reverser

The reverser is an air-operated reversing switch. Its purpose is to change the direction of flow of current through the traction motor fields, thus reversing the rotation of the traction motors. The current does not reverse in the main generator. If the control air pressure is low (should be 80 pounds) or either of the magnet valves on top of the reverser is inoperative, the reverser will not operate properly.

When the locomotive is to be towed in a train, it is advisable to lock the reverser drum in neutral. During normal operation, a locking pin is screwed into the left-hand side of the reverser. To lock the reverser drum in neutral, this pin

should be removed and inserted in the hole on the opposite side. Turn the drum to its neutral position manually and the pin will engage with the hole in the shaft.

Traction Motors

A traction motor drives each pair of wheels on the locomotive through spur gears. The four traction motors under each unit are interconnected through the traction motor control circuit. The traction motors are air cooled by motor driven traction motor blowers, there being one blower for each motor. Serious damage will result if the traction motor blowers become inoperative. The traction motors under one unit of the locomotive are independent of those under any other unit.

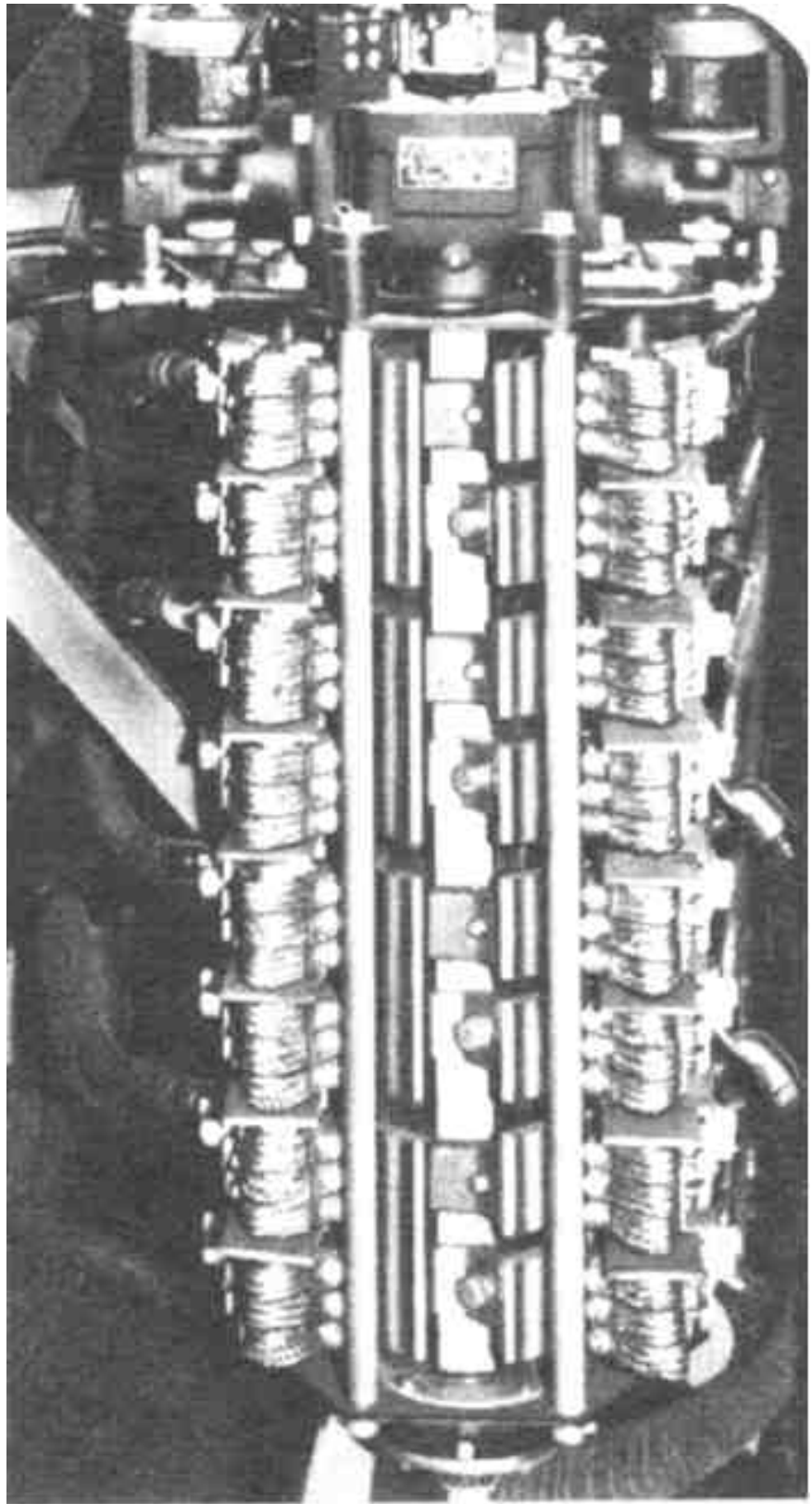

**Reverser
Fig. 6-1**

Fuel Pump Motors

Each engine is equipped with a fuel pump motor rated at 1/4 HP, 1100 RPM. When the master fuel pump switch on the control push-button switch box in the cab is closed, starting and stopping of the motors can be controlled by a toggle-switch mounted on each of the engine control and instrument panels. Operation of the fuel pump is covered in Section 4 of this manual.

Cab Heater Motors

A cab heater motor drives the fan behind each cab heater. The 3-speed switches to start, stop, and control the motor speed are located on the panels above the heaters.

Defroster Motors

Two motors are used to drive blowers in each cab for windshield defrosting. The motors are operated by a switch located on the control push-button switch box mounted at the right of the engineer.

Fuel Pump Contactor

The fuel pump contactor is located in the engine control and instrument panel. All fuel pump contactors throughout the locomotive are controlled by the fuel pump master switch on the control push-button switch box. When the contactor in any unit is closed, the fuel pump can be controlled individually by a toggle-switch mounted on the engine control and instrument panel. Electricity is supplied through this contactor for operating the shutter magnet valves and cooling fan contactors under control of the thermostat switch.

Generator Shunt Field Contactor

This contactor connects the main generator shunt field to the main generator armature. As in the case of the battery field contactor, the generator shunt field contactor is opened during transition from 2 to 3 position and 3 to 2 position, reducing the generator output.

Engine Starting Contactors

The starting contactors are used to connect the battery to the main generator for starting the Diesel engine. These starting contactors are of the magnetic type. There are two for each power plant which are located in the electrical control cabinet. The starting contactors close when the "START" switch-button is pressed and isolation switch is in "START" position. If either one or both of the starting contactors stick in the closed position when the "START" switch button is released, the power plant of that unit will not deliver power.

Battery Charging Contactor

This contactor connects the auxiliary generator to the battery. The reverse current relay closes the battery charging contactor when the auxiliary generator voltage reaches a predetermined setting to charge the battery.

Battery Field Contactor

This contactor closes when the throttle is moved to Run 1 position, connecting the battery to the main generator battery field. During transition from 2 to 3 position and 3 to 2 position, the contactor is opened, reducing the generator output momentarily.

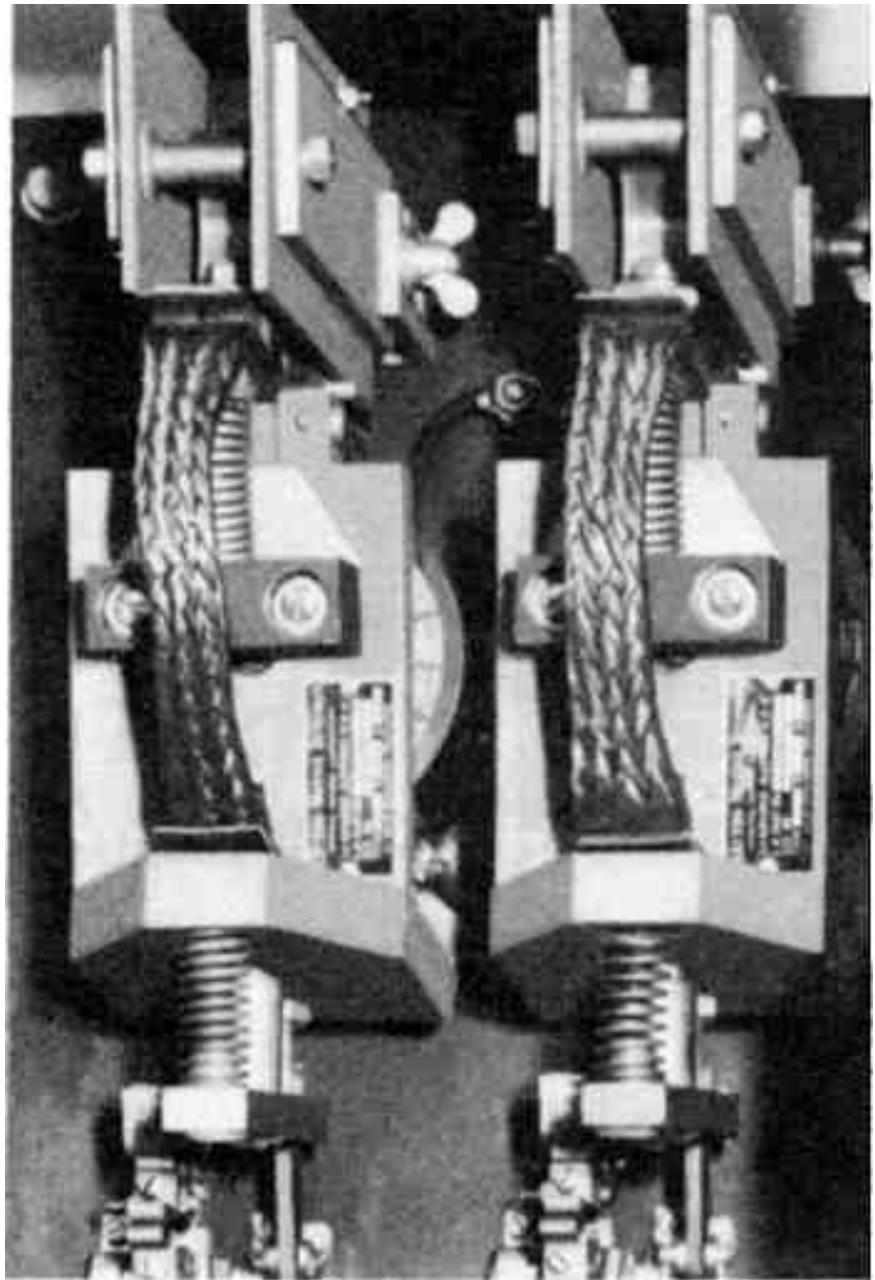

Engine Starting Contactors

Fig. 6-2

Traction Motor Field Shunting Contactors

These contactors connect the shunting resistors across the traction motor fields when transition lever is in No. 2 or No. 4 position. See subject under "Traction Motor Field Shunting Resistor" for further description. The contactors are identified by the symbols "M1," "M2," "M3" and "M4" on the schematic diagrams.

A.C. Motor Contactors

There are four of these contactors in the electrical control cabinet of each unit. Operation of each radiator cooling fan motor is individually operated by its contactor, which in turn is controlled through the thermostat switch. (Also see "Operation of Cooling System," Section 3, and "Transfer Relays" in this section.)

Each of the A.C. fan motor contactors are provided with a thermal overload protective device. For information on operation of this protective device, see "Locomotive Protective Devices," Section 2.

Traction Motor Pneumatic Contactors

These contactors change the traction motor connections from series-parallel to parallel, or vice versa. They operate on air pressure through magnet valves.

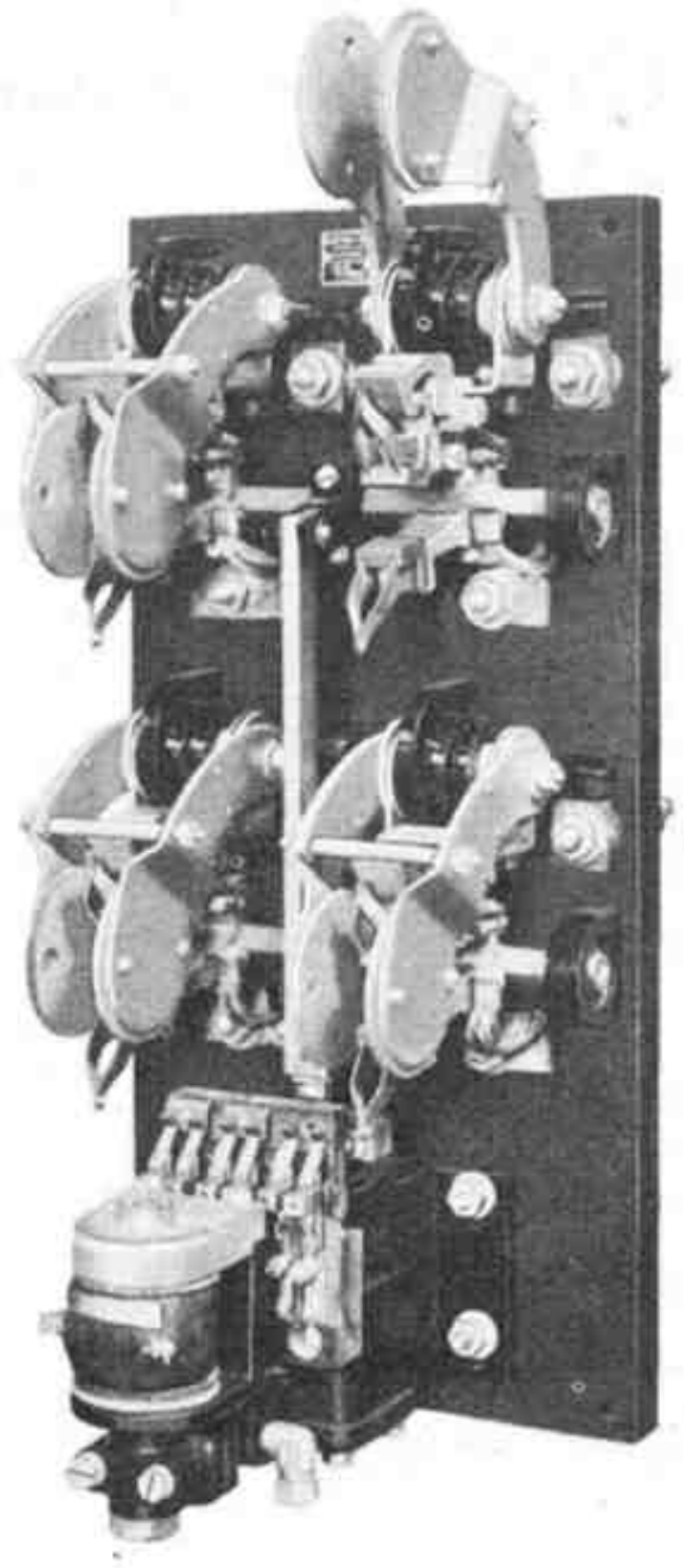

Traction Motor Field Shunting Contactors
Fig. 6-3

Voltage Regulator

The voltage regulator maintains the auxiliary generator voltage at a constant of 74 volts throughout the operating speed range of the engine. This keeps the battery charged and provides a constant source of excitation for the main generator during locomotive operation.

A defective voltage regulator will be evidenced by excessive fluctuation of the ammeter in the electrical control cabinet. A defective auxiliary generator will affect the battery charging rate and the excitation of the main generator.

Reverse Current Relay

This relay prevents the battery current from "motoring" the auxiliary generator by opening the battery charging contactor when the auxiliary generator voltage drops below the battery voltage.

Parallel Relay

This relay is energized when the transition lever is in the No. 3 and No. 4 positions, and operates in conjunction with the time delay relay to close the traction motor parallel (PI, P2, P3, P4) contactors. It also operates in conjunction with the main generator shunt field and battery field contactors to cause the latter to open during transition from No. 2 to No. 3 position and N. 3 to No. 2 position.

Time Delay Relay

The function of this double-acting relay is to allow the main generator voltage time to decrease before closing the parallel contactor (P1) during transition from No. 2 to No. 3 position or opening "P1" during transition from No. 3 to No. 2 position. The relay is a complete, self-contained, sealed unit mounted on a panel in the electrical control cabinet.

Ground Protective Relay

If a ground occurs in the high voltage system, this relay will open the battery field and main generator shunt field contactors and bring the engine to idle except when the throttle is in the 5th or 6th position and in this event the engines will be stopped. Should this occur, isolate the engine and reset the relay by means of the reset lever.



Fig. 6-4

Place the engine back on the line. If the relay repeatedly opens when the engine speed is increased, isolate that power plant. A knife-switch in the electrical control cabinet renders the ground protective relay inoperative when opened. The switch is provided for use during certain electrical tests during maintenance operations. It should not be opened on the road except under circumstances authorized by definite instructions issued by the particular railroad on which the locomotive is operating.

No A.C. Voltage Relay

This relay is in the alternator circuit and should the A.C. voltage fail, the alarm bell rings and the "No A.C. Voltage" warning light (blue light) comes on. The engine speed will return to idle except when the throttle is in the 5th or 6th position, and in this event the engines will be stopped.

Transfer Relays

There are two of these relays in each unit. When operated, these relays establish a circuit to the radiator cooling fan motor contactors. One relay controls fan motors Nos. 1 and 4, the other controls fan motors Nos. 2 and 3.

The sequence of operation of the four cooling fans is changed by operation of the transfer relays. This is provided so that all four fans will get approximately equal work and to avoid the probability of the last fan never working.

Wheel Slip Relays

There are two wheel slip relays (WSR-1 and WSR-2). Each relay has two normally open contacts. In the event of a pair of wheels slipping, the coil connected to that motor will be energized. One of the contacts will light the wheel slip light and the other will deenergize the main generator shunt field operating coil, thereby dropping generator shunt field and battery field. Power output will be reduced momentarily until slipping stops.

When wheels slip, it is necessary to reduce the position of the throttle until the wheels stop slipping and then reapply the power by opening the throttle gradually. The relay will not operate if a pair of wheels should stop during dynamic braking. If necessary to use sand, it should be applied (sparingly) only after the wheels stop slipping.

Alarm Signal Relay

This relay operates with the signal lights (Hot Engine, Boiler Off and Low Oil Pressure) to ring the alarm bells throughout the locomotive.

Isolation Switch

The isolation switch is located on the engine control and instrument panel. Its purpose is to open and close the control circuit of the unit as occasion demands. When starting the Diesel engine, this switch must be in the "START" position. After engine is running, move switch to "RUN" position. This will connect the control circuit of the unit to the engineer's controller. If it becomes necessary to isolate the unit, the isolation switch should be moved to the "START" position. This will bring the engine to idle and cut off the power of this unit. See subject under "Isolating and Stopping an Engine While Under Power," Section 2 of this manual.

NOTE: If isolation switch is in "RUN" position and engine shut down, the low oil pressure signal light and alarm bell will operate.

Pneumatic Control Switch

The pneumatic control switch is an air-operated electric switch located on the right-hand side of the cab, below the window. The purpose of this switch is to reduce the power of the locomotive by bringing the speed of the engines to idle when certain air brake applications take place (see above subject under "Locomotive Protective Devices," Section 2). The switch has a manual reset button which must be pulled out after the air brakes have been released. This switch is referred to as the "PC" switch. The effect of the "PC" switch on the various circuits of the locomotive can be found in the wiring diagram.

Main Battery Switch

This switch isolates all circuits from the battery except the external charging receptacle. The switch should be opened when locomotive is left standing with engines shut down, or when charging battery from an external source.

Thermostat Switch

Engine water temperature control is automatic and is obtained by automatic operation of the shutters and each of the four cooling fans separately.

The automatic temperature control system consists of a thermal element with its contact block and fingers, four contactors, two transfer relays, two sets of shutters, and four cooling fans driven by 12 HP A.C. motors. The thermal element with its contact block and fingers is located in the engine water outlet pipe, the control relays and contactors are located in the electrical control cabinet, and the four cooling fans in the main hatch over the engine.

When the engine water discharge temperature reaches 166 deg F., the shutters on both sides of the unit open automatically. Thereafter, with approximately each 3 deg F. rise in water temperature, one fan will be started as required until, if necessary, all four fans are running. When the temperature of the cooling water drops, the fans will not cut out one by one, but will remain running until the water temperature drops to 163 deg F., when all four fans will shut off and the shutters will close simultaneously.

Auxiliary Generator Switch

One switch is located in the electrical control cabinet of each unit. All battery charging equipment of one power plant (auxiliary generator, reverse current relay, battery charging contactor, alternator field circuit and voltage regulator) is isolated from the battery when this switch is open.

Lighting Switch

The lighting circuits of the locomotive are connected to this double-pole single throw switch which is located on the distribution panel of the electrical control cabinet.

Engine "Start" and "Stop" Switches

These switches are located on the engine control and instrument panel. They will operate only when the isolation switch is in "START" position and control switch, in the control push-button switch box, is closed. The

"START" switch operates the starting contactors. The "STOP" switch energizes the "D" magnet valve in the electro-pneumatic governor control, stopping the engine. The "STOP" switch will not stop the engine if the electric control air pressure is not up to normal.

Fuel Pump Switch

This is a push-button switch located in the control pushbutton switch box at the right of the engineer. The fuel pump contactors throughout the locomotive are controlled by this master switch. When this switch is closed, each fuel pump motor can be individually controlled by a toggle switch located on the engine control and instrument panel.

Control Knife Switch

This switch is located on the distribution panel and controls battery power to the relays, contactors, etc., in the control circuit.

Fuse Test Switch

The fuse test switch is located on the distribution panel and is connected in parallel with the fuse test blocks. To test a fuse, turn fuse test switch on to light lamp, place fuse to be tested across fuse test blocks and turn switch off. If lamp goes out, fuse is blown. The lamp socket can also be used to check a lamp.

Engine Room Light Switches

The two (three-way) switches operate independently of each other to turn the engine room lights on or off. If the lights are on, either switch will turn them off, and vice versa.

Control Push-Button Switch Box

For information refer to Section 1.

Low Oil Pressure Alarm Switch

For information refer to "Locomotive Protective Devices," Section 2.

Lube Oil Suction Alarm Switch

For information refer to "Locomotive Protective Devices," Section 2.

Engine High Temperature Alarm Switch

For information refer to "Locomotive Protective Devices," Section 2.

Ground Protective Relay Switch

This switch opens the circuit to the operating coil of the ground protective relay. See paragraph on "Ground Protective Relay" in this section.

Battery Charging Resistor

This resistor is connected in series with the auxiliary generator. It prevents excessive battery charging rate.

Generator Shunt Field Resistor

This resistor is connected in series with the main generator shunt field. Its purpose is to regulate the shunt field current.

Generator Shunt Field Discharge Resistor

This resistor shunts the main generator shunt field to reduce the high induced voltage when generator shunt field contactor opens.

Battery Field Discharge Resistor

This resistor shunts the main generator battery field to dissipate the high induced voltage when the circuit to the battery field is opened.

Traction Motor Field Shunting Resistor

This resistor is connected across the traction motor fields when the traction motor shunt contactors close.

ELECTRICAL CONTROL CABINET

The electrical control cabinet contains the following high and low voltage equipment. The high voltage equipment in this cabinet should never be worked on when the unit is in operation, as the voltages produced by the main generator are dangerous.

High Voltage

- 1. Time delay relay.
- 2. Motor field shunting contactors-4-pole.
- 3. Transition meter shunt.
- 4. Ground relay knife switch.
- 5. Ground protective relay.
- 6. Wheel slip relays.
- 7. Parallel relay.
- 8. Shunt field discharge resistor.
- 9. Shunt field contactor.
- 10. Shunt field contactor resistor.

- 11. Reverser.
- 12. Pneumatic contactors.
- 13. Wheel slip relay resistors.

Low Voltage

- 1. Battery field contactor.
- 2. Auxiliary generator ammeter.
- 3. Reverse current relay.
- 4. Auxiliary generator knife switch.
- 5. Battery charging contactor.
- 6. Battery charging fuse-150 amp.
- 7. Auxiliary generator field fuse-30 amp.
- 8. Battery field fuse-80 amp.
- 9. Signal relay.
- 10. Starting contactors.
- 11. Voltage regulator.
- 12. Battery field discharge resistor.

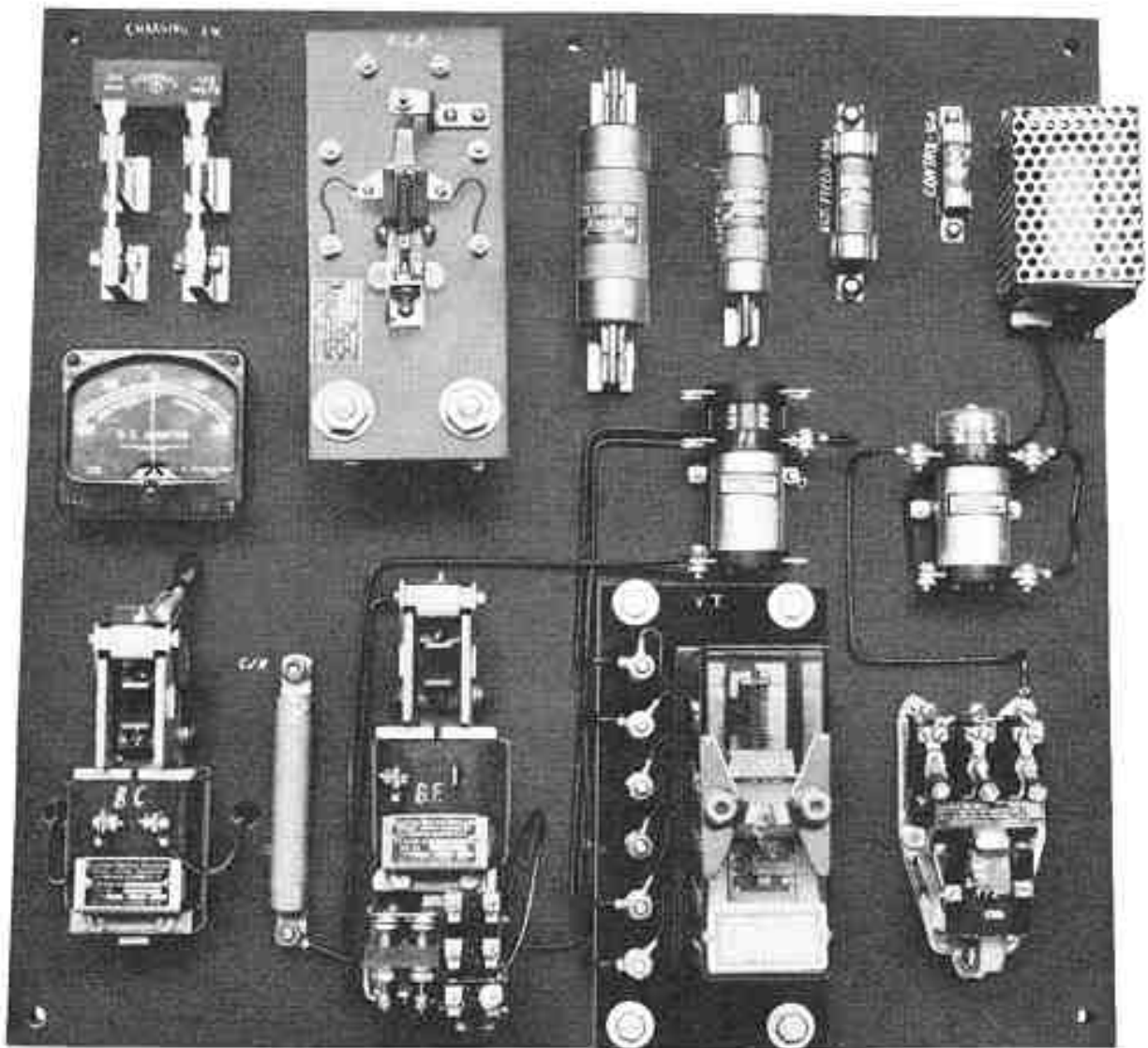

Low Voltage Panel Fig. 6-5

Distribution Panel

- 1. Main battery switch.
- 2. Master control knife switch and 80-ampere control fuse.
- 3. Master light switch and 30-ampere fuse.
- 4. Automatic train control-speed governor knife switch, and 60-ampere fuse.
- 5. Ammeter (battery charge).
- 6. Starting fuse (400-amp.).
- 7. Fuse test blocks and test light.
- 8. External charging fuse.
- 9. Steam generator fuse.
- 10. Other fuses on low voltage control and lighting circuits.

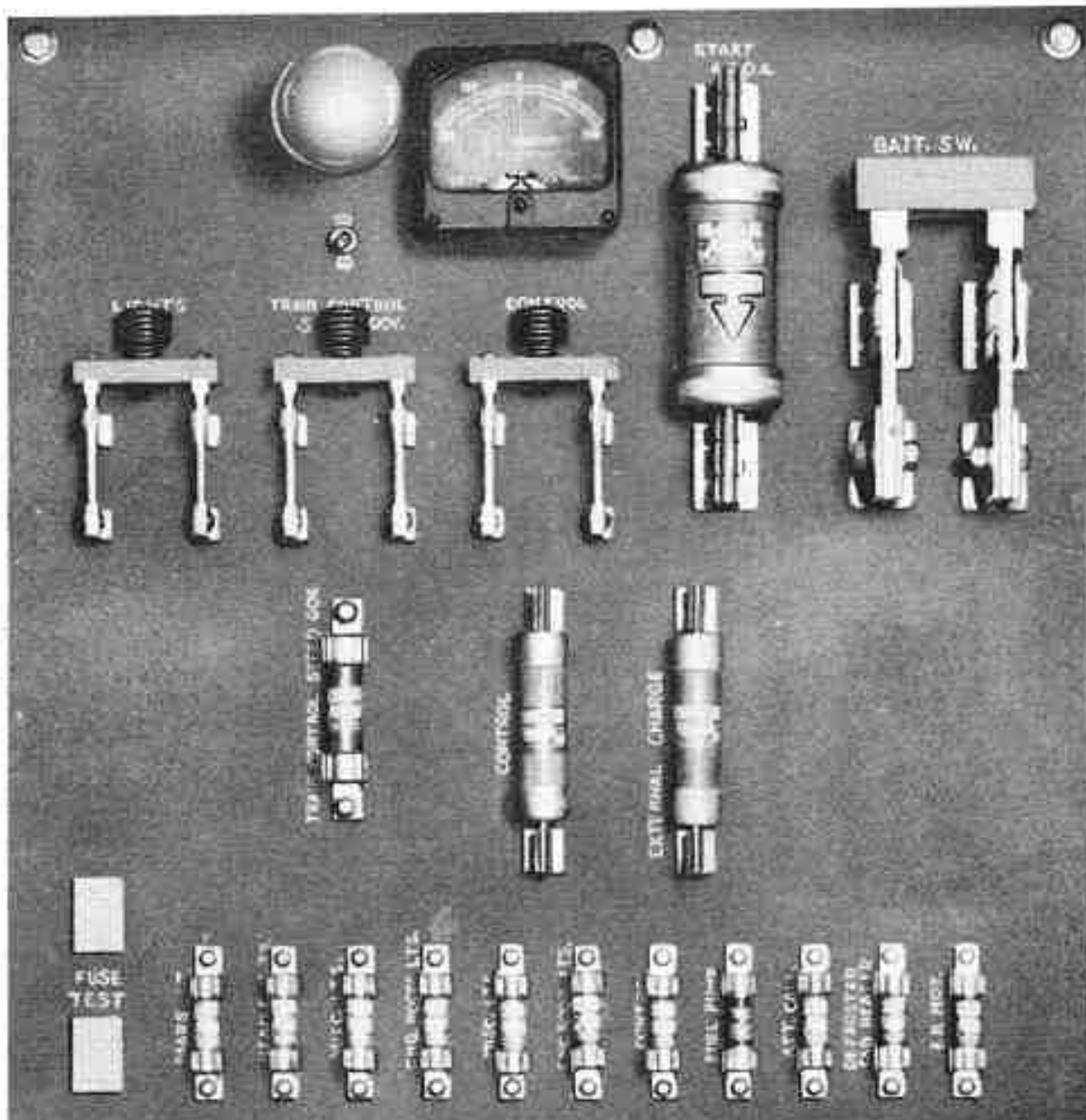

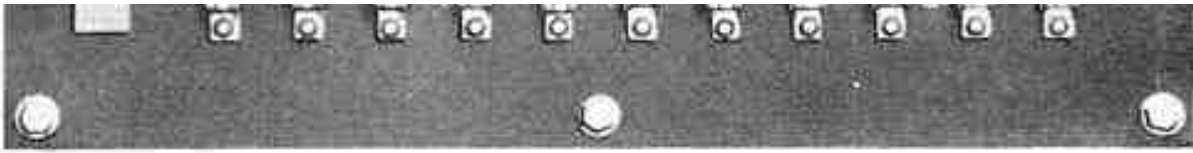

Distribution Panel
Fig. 6-6

Load Regulator and Pilot Valve Operation

The load regulator is divided into two sections: the pilot valve which is attached to the engine governor, and a self-contained unit in a structural steel frame, consisting of an hydraulic vane-type motor attached to a commutator-type rheostat.

The load regulator is used to vary the load on the Diesel engine for any given engine speed, thereby allowing the engine to determine the load which it can carry. If the engine governor demands more fuel than a predetermined setting, the load regulator reduces the load on the engine by reducing the field excitation of the main generator, and vice versa. In this way, overloading the engine is prevented if some of the cylinders should become inoperative.

A.C. Circuit

- 1. Four cooling fan motor contactors.
- 2. Two transfer relays.
- 3. Relay for thermostat switch.
- 4. "No A.C. Voltage" relay.
- 5. Alternator field fuse-35-ampere.

Ammeters

The ammeter in the electrical control cabinet indicates auxiliary generator output and does not necessarily agree with the ammeter on distribution panel. The ammeter on the distribution panel shows net charge or discharge through the battery, except starting current or current from an external charging source.

Speed Recorder

The speed recorder is an hydraulic-operated speedometer with recording tape. It is driven from an axle on the No. 1 truck of the "A" unit, by a flexible cable.

A micro-switch inside the recorder cover operates at a predetermined setting, acting as a maximum speed governor.

Master "E" Magnet Valve

This magnet valve controls the air supply to the "A," "B," and "C" valves of the electro-pneumatic governor

control. De-energizing this valve will stop the engine if throttle is in Run 5 or Run 6, or bring the engine to idle in any other throttle position.

Electro-Pneumatic Governor Control Magnet Valves

This assembly consists of four magnet valves-designated as "A," "B," "C," and "D" valves. Various combinations of these valves control engine speed in accordance with throttle position. The following chart indicates valve combinations and engine speeds at all throttle positions:

THROTTLE POSITION	ENGINE SPEED CHART				ENGINE SPEED RPM
	MAGNET VALVES ENERGIZED				
	A	B	C	D	
OFF					0
IDLE					275
1					275
2					350
3			*		425
4	*		*		500
5		*	*	*	575
6	*		*	*	650
7		*	*		725
8	*				800

Traction Motor Control Circuit Explanation

A sequence test of the control circuit should be made by the maintainer before dispatching locomotive from maintenance point.

A definition and description of transition is given in Section 2 of this manual. The following explanation describes what takes place during transition.

FORWARD TRANSITION

(Train Speed Increasing)

After engines have been started and placed "on the line," the following must be closed before the locomotive will move:

Generator field switch.

Transition lever (in No. 1 position).
Reverse lever (in forward or reverse).
Reverser (in forward or reverse).
Starting contactor interlocks.
Ground protective relay interlock.

1. No. 1 Transition Position (Series-Parallel):

The following operations occur when the transition lever is in No. 1 position and throttle is moved from "IDLE" to Run 1

- a. "SH" and "BF" contactors close.
- b. "S" contactors close (S14 and S23).

2. No. 2 Transition Position (Series-Parallel-Shunt):

When transition lever is moved to No. 2 position

- a. "M" contactors (M1, M2, M3, M4) close, thus shunting the main field of each traction motor.

3. No. 3 Transition Position (Parallel):

When the transition lever is moved to the No. 3 position

- a. Parallel relay (PR) closes.
- b. Shunt field contactor (SH) opens.
- c. Battery field contactor (BF) opens.
- d. Motor shunting contactors (M) open.
- e. Time delay relay (VT) closes.
- f. Parallel contactor (P1) closes.
- g. Series contactor (S14) opens.
- h. Parallel contactor (P4) closes.
- i. Parallel contactor (P2) closes.
- j. Series contactor (S23) opens.
- k. Parallel contactor (P3) closes.
- l. Generator shunt field and battery field contactors (SH and BF) close.

4. No. 4 Transition Position (Parallel-Shunt):

When the transition lever is moved to the No. 4 position

- a. Motor field shunting contactors (M) close.

BACKWARD TRANSITION

(Train Speed Decreasing)

As train speed decreases due to a grade, the transition lever must be moved in accordance with transition meter indication to prevent overload of the electrical equipment. See Section 2 of this manual for operating details.

1. Parallel-Shunt to Parallel Transition:

The following operations occur when the transition lever is moved from No. 4 to No. 3 position

- a. "M" contactors open.

2. Parallel to Series-Parallel-Shunt Transition:

When transition lever is moved from No. 3 to No. 2 position

- a. Parallel relay (PR) opens.
- b. "SH" and "BF" contactors open.
- c. Time delay relay (VT) opens.
- d. "P1" contactor opens.
- e. "S 14" contactor closes.
- f. "P4" contactor opens.
- g. "P2" contactor opens.
- h. "S23" contactor closes.
- i. "P3" contactor opens.
- j. "SH" and "U" contactors close.
- k. "M" contactors close.

3. Series-Parallel-Shunt to Series-Parallel Transition:

When transition lever is moved from No. 2 to No. 1 position --

- a. "M" contactors open.
- b. "SH" and "13F" contactors remain closed.
- c. "S14" and "S23" contactors remain closed.

4. Series-Parallel to "OFF" Transition:

When throttle is moved to "IDLE" position and transition lever to "OFF"

- a. "S14," "S23," "SH" and "BF" contactors open.

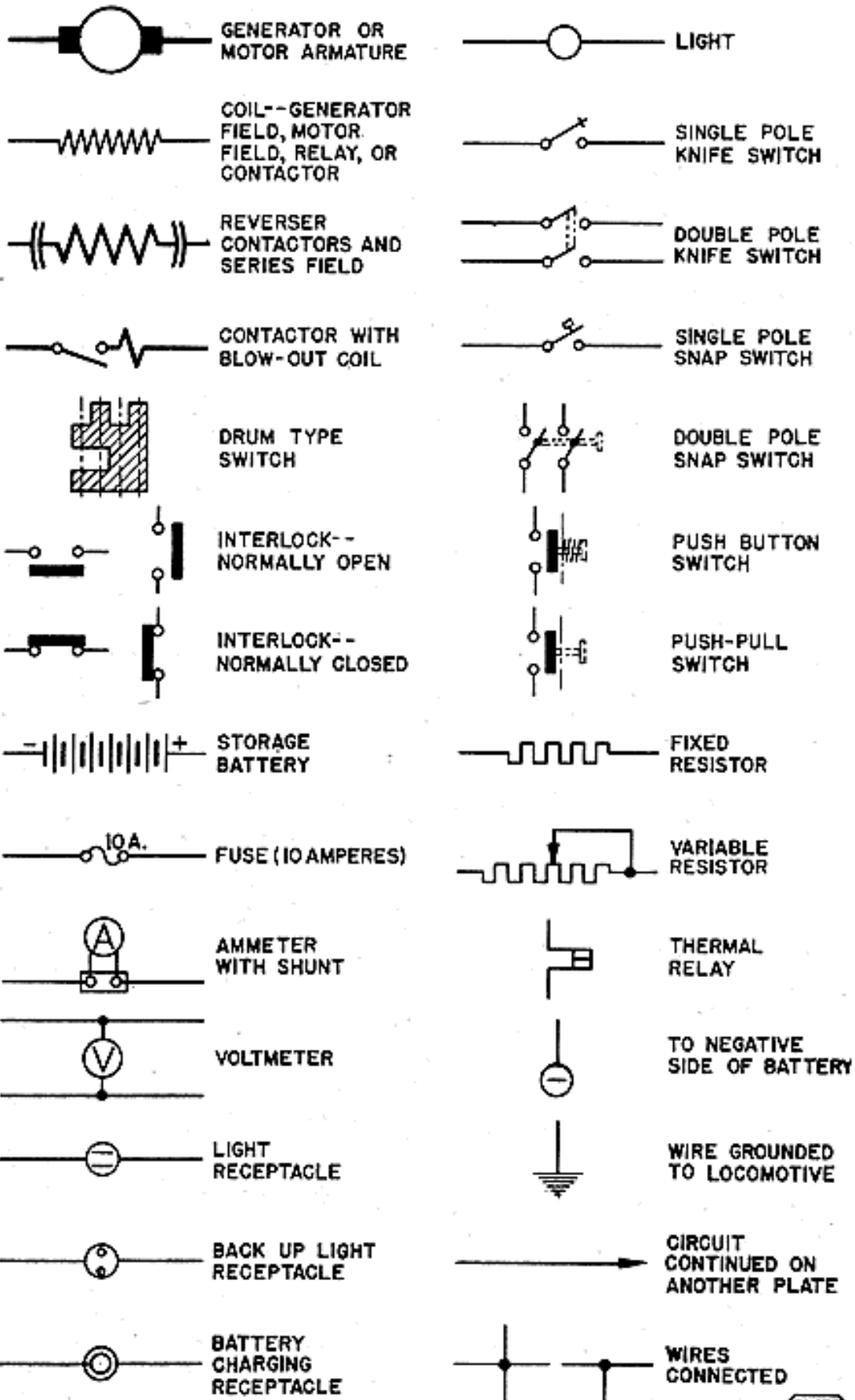

PLATE
3800

LEGEND OF ELECTRICAL EQUIPMENT

The following is a list of abbreviations used to identify electrical equipment on the schematic wiring diagram. The wire designations appearing on the diagram conform with the identification bands on the wires throughout the locomotive. These wire designations are not included in this list.

AV, BV, CV, DV, EV	Electro-Pneumatic Governor Control Valves
BC	Battery Charging Contactor
BF	Battery Field Contactor
Comm	Commutating Field
CL	Class Light or Switch
DIFF	Differential Field
ETS	Engine High Temperature Alarm Switch
FOR	Reverser Magnet Valve-Forward Position
FPC	Fuel Pump Contactor
GA	Gauge Light or Switch
GR	Ground Protective Relay
HDLT	Headlight
LOS	Lube Oil Suction Alarm Switch
M	Motor Field Shunting Contactor Magnet
Valve	
M1, M2, M3, M4	Motor Field Shunting Contactors
N	Number Light or Switch
NVR	"No A.C. Voltage" Relay
OS	Oil Signal Light
P1, P2, P3, P4	Parallel Contactors
PCs	Pneumatic Control Switch
PR	Parallel Relay
RCR	Reverse Current Relay
REV	Reverser Magnet Valve-Reverse Position
RVR	Reverser Interlock
S	Series Contactors (SK S23)
SH	Shunt Field Contactor
SP	Speed Recorder Light
SR	Signal Relay
ST+, ST-	Starting Contactors
START	Starting Field
TSA	Thermostat Switch Assembly
TL	Throttle Light TS
TS	Engine High Temperature Signal Light
VT	Time Delay Relay
WSR1, WSR2	Wheel Slip Relays
WS	Wheel Slip Light

[Typical Wiring Diagram - "A" Unit - Fig. 6-8](#)

ELECTRO-MOTIVE DIVISION
SECTION F2-7-1

GENERAL MOTORS CORPORATION
AIR SYSTEM

SECTION 7

AIR SYSTEM

Air Compressor

Each power plant in the locomotive is equipped with a GardnerDenver type WXE three-cylinder air compressor, rated at 178 cubic feet of air per minute at 800 RPM. It is driven by the shaft of the main generator through a flexible coupling. The compressor has its own oil pump and pressure lubricating system. Oil level in the crankcase can be checked on the bayonet type gauge. Lubricating oil pressure should be from 12 to 15 pounds at 800 RPM and not less than 5 pounds at idle (hot oil). Since each air compressor is directly connected to an engine and in operation at all times when the engine is running, an unloader is provided in the heads of both high and low pressure cylinders which cuts out the compressing action when actuated by air pressure. The unloader accomplishes this by blocking open the suction or intake valves of the high and low pressure cylinders. When the air operating the unloader is cut off, the unloader releases the suction valves and the compressor resumes pumping.

The compressor consists of two low pressure cylinders and one high pressure cylinder. The pistons of all three cylinders are driven by a common crankshaft. The two low pressure cylinders are set at an angle to the vertical high pressure cylinder. Air from the low pressure cylinders goes to an intercooler, or radiator, to be cooled before entering the high pressure cylinder. The intercooler is provided with a pressure gauge and safety valve. The gauge normally reads approximately 32 pounds when the compressor is loaded. The intercooler safety valve is set for 50 pounds. Any marked deviation of intercooler pressure from 32 pounds should be reported to maintenance for attention.

Condensation collects in the sump of the bottom header of the compressor intercooler and should be drained once at each crew change and at the regular maintenance period. A drain valve is provided in each sump for this purpose. Operate the intercooler safety valve by hand, when draining intercooler, to be certain that it functions properly.

Air for operation of the unloader comes from a magnet valve which is actuated by a control circuit in each unit of the locomotive. A pressure switch is located in each unit and connected to the main reservoir. When the pressure in the main reservoir reaches 140 pounds, the pressure switch in that unit closes and energizes the compressor control (CC) wire. The compressor magnet valve opens at the compressor and admits air to the unloader. Similarly, when the main reservoir pressure drops to 130 pounds, the pressure switch will open, de-energizing the

CC wire.

General

From the compressor, the air passes through an oil separator to the aftercooler assembly. It then passes through a sump reservoir to the No. 1 main reservoir under the carbody. The change of air pressure in the No. 1 main reservoir forces the condensation into a second sump located inside the carbody. This sump is provided with a drain valve. The air flow from the No. 1 main reservoir passes through a check valve into the No. 2 main reservoir, under the cab floor in the "A" unit. From the outlet of the second main reservoir, the air passes through an H-type filter to the air brake system and the electrical control air system. Compressed air for operation of the windshield wipers, horns and bell ringer is taken from the line between the two main reservoirs on the No. 1 reservoir side of the check valve in the "A" Unit. See Fig. 7-1.

Electrical Control Air System

Air pressure is used to operate the various electro-pneumatic contactors, reversers, and governor controls in the locomotive. In each unit, compressed air for these purposes is drawn from the discharge line of the No. 2 main reservoir and passes through an air regulator which reduces the pressure to 80 pounds. The control air passes through a filter to the control air reservoir. From the reservoir the air flows to two main distribution points, the electrical control cabinets and the engine control and instrument panels. The air passes through a strainer located near each control panel which collects dirt and moisture remaining in the air.

In the electrical control cabinet, the air pressure operates:

- 1. Reverser.
- 2. P1, P2, P3, and P4 parallel contactors.
- 3. S14 and S23 series contactors.
- 4. Motor shunting contactors.
- 5. Cam-switch and braking contactors (on dynamic brake equipped locomotives only).

In the engine control and instrument panel, air passes through the master "E" magnet valve to a line running to the electro-pneumatic governor control on the engine where air is supplied to magnet valves "A," "B," and "C." A second air line by-passes the master "E" magnet valve and goes direct to the "D" valve. When the operating coil of the master "E" magnet valve is de-energized, no air can pass and the supply to "A," "B," and "C" valves is cut off. The "D" valve is not affected.

Draining of Air System

The air system should be drained periodically to prevent moisture from being carried into the air brake and electric control air systems. The frequency of draining will depend on local conditions and can be determined by practice. It is recommended that draining be done at the time of each crew change, until a definite schedule can be determined by the individual railroad.

The elements of the equipment to be drained are:

- 1. Air compressor oil separator and intercooler.

- 2. Upper sump reservoir.
- 3. Lower sump reservoir.
- 4. No 2 main reservoir under cab floor.
- 5. Type H filter. -
- 6. Electrical control air regulator.
- 7. Electrical control air reservoir.
- 8. Strainers at engine control and instrument panel - and electrical control cabinet.

Electrical Control Air Pressure

Control air pressure is maintained at 80 pounds, plus or minus 3 pounds, by a pressure regulator in each unit. The control air pressure gauge is mounted on the regulator.

If the control air pressure gauge should indicate main reservoir pressure, the regulator valve is probably stuck. Open the drain at the bottom of the regulator. If this does not remedy the condition, a report should be made to maintenance for correction. The main reservoir air pressure in the electrical air system will not cause any serious difficulties for the remainder of the trip.

Sanding

The sanders are operated manually by depressing the sanding bail on the automatic brake valves. The sanders will also operate automatically if an emergency air brake application is made. In some cases railroads have specified that the sanding feature in the automatic brake valve be omitted and a single-acting independent sanding valve be installed.

The sand capacity is four cubic feet in each sand box. This gives a total capacity of 16 cubic feet in each unit.

Windshield Wipers

The speed of the wiper is controlled by the needle valve which turns the wiper on and off. Do not run the wiper on a dry window as dirt on the glass or blade will scratch the glass. The wiper blade should be replaced when the rubber becomes worn or hard.

Bell and Ringer

The 12-inch bell, located behind the pilot of the "A" unit, is operated by a remote controlled air type bell-ringer. The bell operating valve is located at the engineer's control station.

Air Brake System

Refer to instruction pamphlet supplied by the Westinghouse Air Brake Company for instructions on the operation of the air brake equipment. This air brake pamphlet includes piping diagrams and sectional drawings.

[Schematic of Air System -- Fig. 7-1](#)

ELECTRO-MOTIVE DIVISION
SECTION F2-8-1

GENERAL MOTORS CORPORATION
MISCELLANEOUS

SECTION 8

TRUCKS AND MISCELLANEOUS EQUIPMENT

Coupler Arrangement

At the No. 1 end of each "A" unit there are type "E" couplers. Couplers or links are provided between the "A" and "B" units depending on the specifications of the railroad. At the No. 2 end of each "B" unit, there are type "E" couplers.

Removing Wheels

Jacking pads are provided on the body of the locomotive (see Fig. 8-1) for the purpose of removing the weight of the locomotive from the truck prior to dropping any one of the pairs of wheels, and under no circumstances should any of the pairs of wheels be dropped from the truck without first supporting the weight of the locomotive on these jacking pads.

If these instructions are not closely followed, serious damage may result to the carbody and trucks of the locomotive.

Removing Trucks

Fig. 8-1 shows the various jacking pads, blocking pads and their locations, as well as the lift required so the trucks may be removed sideways.

General

If a drop table is not available and a truck is to be removed from one end, the other end must also be raised at least halfway out of the center plate pocket, or 2 inches; otherwise the center plate pocket will be sprung out of shape or cracked.

In cases where an overhead crane is not available and jacks are used for lifting, care must be exercised that jacks on opposite sides of the locomotive are raised equal amounts; otherwise the carbody may be sprung out of shape.

Hoisting levers may require some reworking for individual locomotives and should be carried on the particular locomotive for which they have been fitted.

Blocking should always be provided if carbody is to be held in raised position for any length of time.

Two jacking pads are provided for each end of the locomotive, as indicated on Fig. 8-1. Jacking should always be done on these jacking pads.

Carbody and truck locking plates are removed from underneath the carbody and are located at each side bearing.

Emergency

In case of a wreck, a locomotive may be lifted by the coupler shank, providing a new coupler is at hand and proper blocking is provided between the top and sides of coupler shank and coupler pocket. While Electro-Motive cannot be responsible for possible damage or breakage of parts by lifting in this manner, it has been done on several occasions without damage but should only be done in extreme emergencies with the railroad taking all the responsibility.

Truck and carbody locking plates on all locomotives have sufficient strength to lift the trucks with the carbody. If trucks are to be lifted with the carbody, springs should be blocked, as this will save approximately 3 inches of jacking. Blocking can also be placed between each journal box and pedestal tie bar to further reduce the lift.

Journal Boxes (Hyatt)

All of the journal boxes are similar internally but vary externally according to whether they are plain boxes or have a speed recorder connection. The speed recorder connection is mounted on the No. 1 axle journal box of the No. 1 truck at the left-hand side of the locomotive.

Each journal box is equipped with a "stench bomb." This device consists of a cylindrical container holding a liquid which, when heated, gives off an extremely pungent and penetrating odor. The container is sealed with a bismuth solder plug. If for any reason the temperature inside the journal box exceeds 220 deg F., the plug melts, instantly releasing the stench agent to the atmosphere.

When the resultant odor is detected by the locomotive or train crews, the train should be stopped at once and the overheated bearing located.

An examination should then be made to determine the cause of the overheating and proper precautions taken before operating the equipment further. When the equipment reaches the shop, all parts of the bearing and journal box should be thoroughly examined, any necessary repairs made, and a new "stench bomb" applied.

[Truck Removal and Locomotive Lifting - Fig. 8-1](#)

ELECTRO-MOTIVE DIVISION
SECTION F2-9-1

GENERAL MOTORS CORPORATION
TROUBLE SHOOTING

SECTION 9

TROUBLE SHOOTING

If Fuel Does Not Show In Sight Glass

- 1. If fuel pump does not run:
 - a. Check all fuses in circuit.
 - (1) The 80- and 15-ampere control fuses on distribution panel.
 - (2) The 15-ampere fuel pump fuse on the distribution panel. (3) The 10-ampere fuel pump motor fuse on distribution panel.
 - b. Check switches in circuit.
 - (1) Control knife switch on distribution panel should be closed.
 - (2) Check "PC" switch (pull out button to reset).
 - (3) Fuel pump switch on control switch box in cab.
 - (4) Fuel pump switch on engine control and instrument panel should be in "ON" position.
 - c. Check electric connector to fuel pump motor.
- 2. If fuel pump motor is running but no fuel is being delivered:
 - a. Check fuel pump coupling and shaft.
 - b. Check fuel supply and emergency fuel cutoff valve.
 - c. Check for air leaks in suction line due to broken pipe or loose connection.

If Engine Does Not Rotate When Attempt Is Made To Start

- 1. Repeat customary sequence of operations in starting engine, making sure that all controls and switches are in the correct position.
- 2. Check all fuses affecting starting circuit:
 - a. Starting fuse. This is the 400-ampere fuse on the distribution panel.
 - b. 80- and 30-ampere control fuses on the distribution panel.
- 3. The battery may be too weak to turn engine over. Turn on engine room lights and note whether they become dim or go out when the "START" button is pressed.
- 4. Check to see that both the starting contactors go in when "START" button is pressed in.

If Engine Rotates But Does Not Fire When "START" Button Is Pressed

- 1. Check cylinder test valves at each cylinder, making sure that they are closed.

- 2. Check injector linkage in event that it may be stuck in shutdown position or held in that position by throttle being latched in "STOP" position.
- 3. Check to see that overspeed trip shaft is latched in "Run" position.

If Locomotive Does Not Move When Throttle Is Opened

(Some of the items listed below would cause a loss of load on one engine which would cause slow acceleration.)

- 1. Check "PC" switch (pull out button to reset).
- 2. Check hand brakes in every unit to see that they are released.
- 3. Repeat movement of air brake valve to release all brake shoes.
- 4. Check to see that generator field switch at control switch box is closed and fuse good.
- 5. Check electric control air pressure (should be 80 pounds).
- 6. Reverser might be in wrong position.
- 7. Check to see that ground protective relays are not tripped.
- 8. Check all fuses:
 - a. 80- and 30-ampere control fuses on the distribution panel.
 - b. 80-ampere battery field fuse (panel on which battery charging switch is located).
- 9. The generator shunt or battery field contactors might be open or making poor contact.
- 10. If starting contactors or wheel slip relays stick in the closed position, the generator of that power plant WILL NOT deliver power.
- 11. The "No A.C. Voltage" relay must be in operating position, or the power plant of that unit will not deliver power, and the engine cooling fans and traction motor blowers will not operate.

If Engine Cooling System Fan Motors Fail To Operate

- 1. Check "PC" switch.
- 2. Check 15-ampere fuel pump fuse on distribution panel.
- 3. Check 10-ampere fuel pump motor fuse on distribution panel.
- 4. The fuel pump contactor may be defective.
- 5. The temperature control relay may be defective.
- 6. The thermostat switch may be defective.
- 7. The transfer relays may be defective.
- 8. Check A.C. contactors; contacts may be dirty or their coils defective.
- 9. Check 35-ampere alternator field fuse. (Blue light will light and alarm will sound if this fuse is blown.)
- 10. Check 80-ampere control fuse on distribution panel.

Loss Of Load On An Engine

To detect a loss of load on an engine, look at the load indicator on the governor. After the engine and generator have had a chance to balance up (about 30 seconds), the load indicator should agree approximately with the indicator on the back of the electro-pneumatic governor control. If the indicator on the governor is low, the causes may be:

- 1. The motors across that generator are in "series-parallel" while in the other units, the motors are in

"parallel."

- 2. The "BF" or "SH" contactor is open. This may be caused by:
 - a. Ground relay tripped.
 - b. Starting contactor interlock open.
 - c. Wheel slip relay stuck.
 - d. Cam-switch interlock open. (Only on locomotives equipped with dynamic brake.)
 - e. Contact on isolation switch open.
 - f. Parallel relay contact open.
 - g. Parallel contactor interlock open (contactor stuck).
 - h. The 50 ohm resistance in series with shunt field contactor coil open.
- 3. Battery field fuse blown.
- 4. Dirty or improperly seated contacts any place in the power or generator field circuits. In correcting any of these defects, it is important that the power plant being worked on be isolated.
- 5. The "No A.C. Voltage" relay open because de-energized or stuck

Lack of Power

In the engine this may be due to poor combustion, insufficient air, lack of fuel, poor fuel, restriction in exhaust, incorrect timing, or leaky exhaust valves.

In the electrical system, lack of power may be caused by low generator field excitation. Low generator field excitation may be due to a faulty connection in the generator battery field circuit, a faulty auxiliary generator or voltage regulator, a weak battery, or an open generator field contactor. Lack of power may also be due to faulty traction motors or generators, traction motor contactors, a faulty load regulator, pilot valve, or improper setting of pilot valve linkage.

In short, anything preventing the generator from delivering its full output, or preventing the traction motors from delivering their full power, will cut down on locomotive power.

If Hot Engine Alarm Sounds

- 1. Check engine temperature gauges to determine which engine is causing alarm.
- 2. Take engine "off the line."
- 3. Check for cause-inoperative shutters, fans not running, low water, defective water circulating pump or circulation.
- 4. If individual fan motors fail to operate, check temperature overload switches on A.C. contactors. Reset if necessary.

If Locomotive Stops In Operation

If the locomotive suddenly becomes inoperative, check the control fuses (80- and 30-ampere) on the distribution panel. A wire may have been jarred loose, or may be burned off. The fuel supply may have stopped. The "PC" switch may have opened. The ground protective relays may have tripped in all units.

If An Engine Fails To Stop

Stop engine with the layshaft manual control lever if engine fails to stop when the throttle is placed in the shutdown position or the "STOP" button is pressed on the engine control and instrument panel. Check for binding linkage, inoperative electro-pneumatic governor control, faulty governor, or defective "D" valve.

Engine Stopped

When one engine in the locomotive stops, the low oil pressure alarm will operate throughout the locomotive, provided the isolation switch of the stopped engine is in "RUN" position.

To locate the trouble, place isolation switch in "START" position to stop the alarm bells. Check for the most usual causes:

- 1. Lack of fuel. Check fuel pump operation and fuel supply as explained under "FUEL FAILURE," Section 5.
- 2. Overspeed Trip. Check position of overspeed trip lever and reset if necessary.
- 3. Ground Protective Relay. Examine ground protective relay and reset if necessary. Tripping of the ground protective relay will not cause an engine to stop unless the locomotive throttle is in Run 5 or Run 6. After starting engine, check ground relay and starting contactors.
- 4. "No A.C. Voltage" relay de-energized when throttle is in 5th or 6th position.

If All The Engines In The Locomotive Stop, Check The Following:

- 1. Position of locomotive throttle to see that it is not in "emergency stop" position.
- 2. Fuel pump switch on control push-button switch box.
- 3. Fuel pump fuse (15-amp.) on distribution panel of operating unit.
- 4. "PC" switch.

Low Oil Pressure Alarm Or Lube Oil Suction Alarm

The alarm may be intermittent or steady. If intermittent, refer to "Lube Oil Suction Gauge and Alarm Switch," Section 4. Determine which engine is causing the alarm and shut it down immediately.

When The Alarm Is Steady:

- 1. Check for stopped engine. If one is stopped, proceed as under "ENGINE STOPPED" above.
- 2. When engines should be over idling speed by throttle control, check for engine idling.
 - a. Place isolation switch in "START" position.
 - b. Check main bearing oil pressures. Shut engine down if readings are below recommended minimum figures.
 - c. If pressures are normal, speed engine up slightly with layshaft manual control lever until load indicator reaches the second or third mark above "IDLE." Observe action of pressure gauges during speed increase. Should pressures rise properly, place isolation switch in "RUN" position, retaining firm grip on layshaft manual control lever as explained under "STARTING AND PLACING ENGINE ON THE LINE WHILE LOCOMOTIVE IS UNDER POWER." Allow the engine to speed up slowly, watching pressure gauges closely. When engine is up to speed, observe

gauges for any irregularity or fluctuation of readings. In any case of doubt as to whether gauge action is normal and correct, shut engine down at once.

- d. Should the engine fail to speed up when the isolation switch is moved to "RUN" position, check the ground protective relay. Tripping of the ground protective relay may have been the original cause for the engine dropping to idling speed and the low oil pressure alarm a secondary action, due to excessively hot or low viscosity oil, after the engine slowed down.
- 3. When all engines are at "idle" when low oil pressure alarm sounds:
 - a. Place all isolation switches in "START" position.
 - b. At each engine in turn, place isolation switch in "RUN" position for a few seconds and then back to "START." At any engine which causes the alarm to ring when isolation switch is moved to "RUN," check main bearing oil pressures carefully. Shut down engine if pressures are lower than recommended minimum readings.
 - c. Test engine oil pressures by speeding up engine slightly as in 2(c) above. **CAUTION:-ON LOCOMOTIVES EQUIPPED WITH DYNAMIC BRAKE. - DO NOT ATTEMPT TO MAKE CHECK IN 3 ABOVE WHEN DYNAMIC BRAKE IS APPLIED.**

Exhaust Smoke

Smoke at the exhaust is usually an indication of poor combustion of fuel, but may be due also to excess lubricating oil passing into the combustion chamber. Fuel in a partially burned condition, or engine overload, will cause a black exhaust. If fuel is not igniting, the exhaust may show blue. Blue smoke may appear at light loads, or upon starting, due to low temperature of the combustion chamber. Misfiring, improper fuel, incorrect timing, a faulty injector, or insufficient air, may be the cause of exhaust smoke.

Smoke may also be an indication of a continuous engine overload due to improper pilot valve adjustment, plugged pilot valve feed line, or inoperative load regulator.

If Auxiliary Generator Ammeter Always Shows Zero

- 1. See that auxiliary generator switch is closed.
- 2. Check all fuses in circuit affected:
 - a. 30-ampere auxiliary generator field fuse.
 - b. 150-ampere battery charging fuse.
- 3. Auxiliary generator not operating. In this case, or if replacing fuses is not corrective, the condition should be reported at the maintenance point.

If Air Pressure Does Not Build Up

- 1. Check to see that angle cocks and main reservoir drain valves are in proper position.
- 2. Check main reservoir safety valve in event that it might be stuck open. A light tap may seat it.
- 3. Blow out filter and air compressor governor.

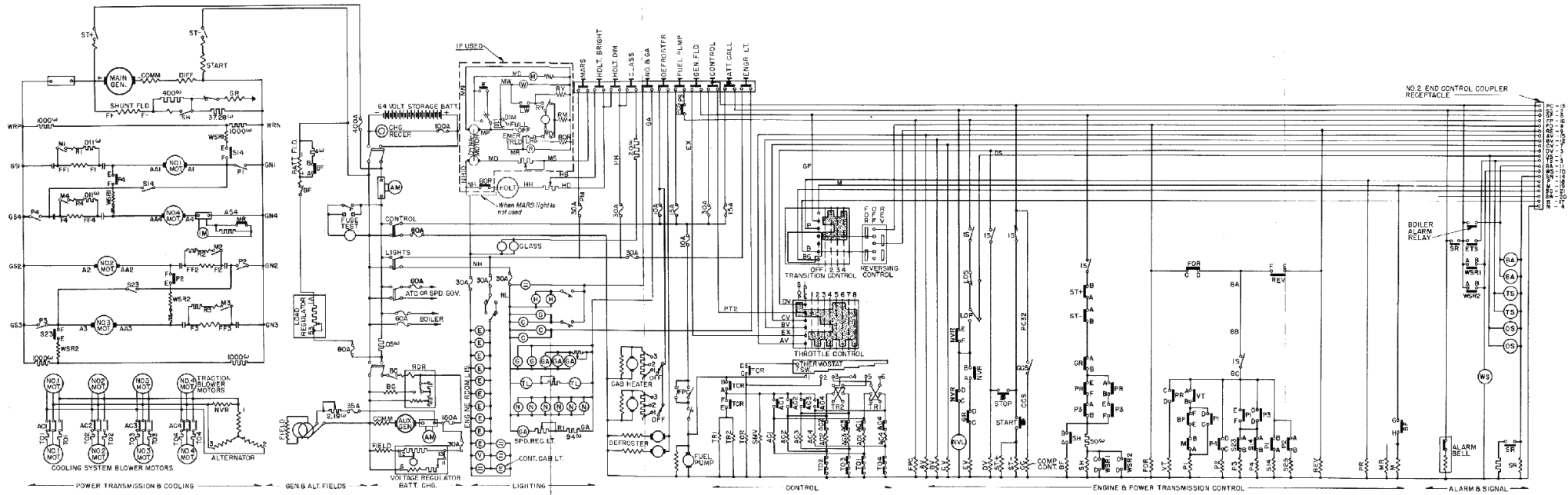

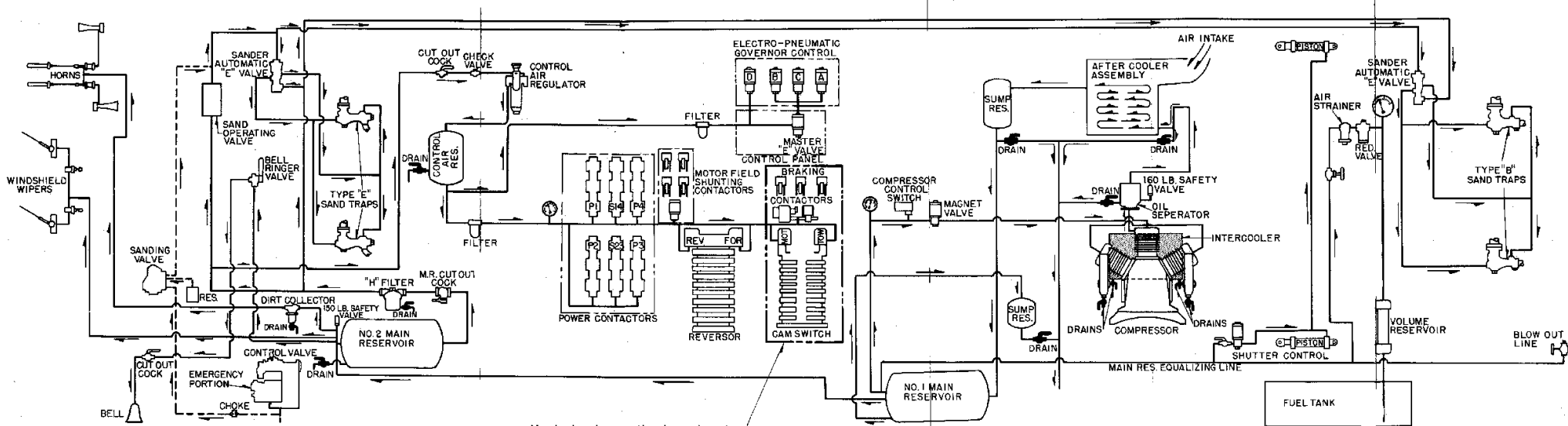

Used when locomotive is equipped with dynamic braking.

Key: -----When locomotive is equipped with automatic emergency sanding

NOTE: When raising car body for truck removal, the opposite end of car body from truck to be removed must be raised high enough to separate center plates. Failure to do so may result in breaking of center plates.

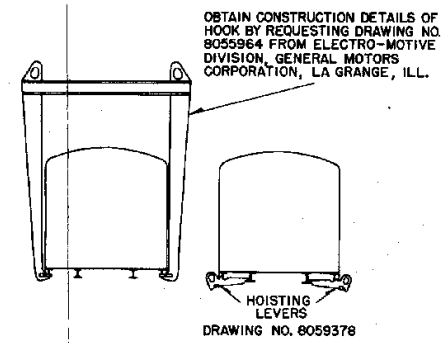
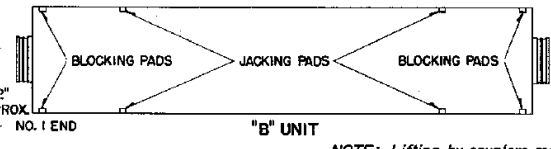
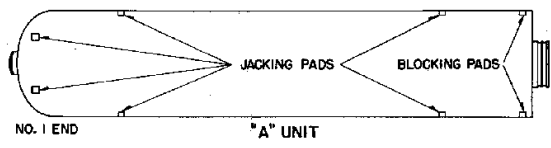
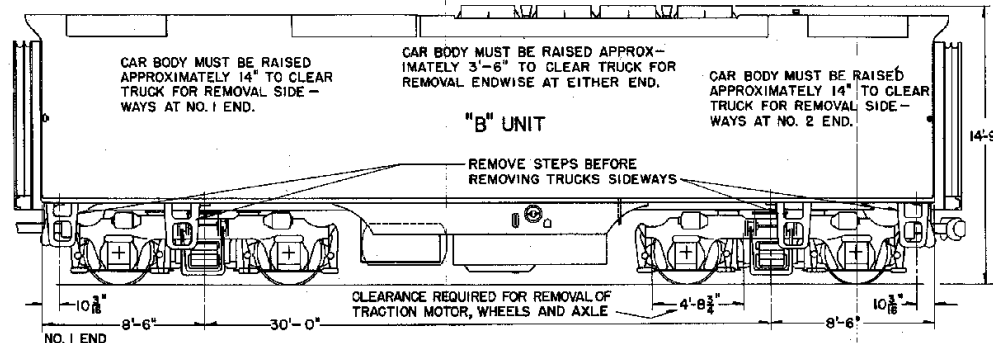
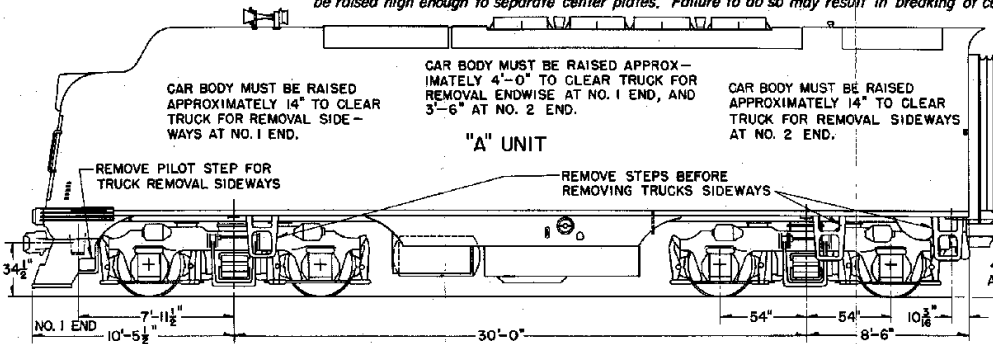

NOTE: Lifting by couplers may result in breaking or bending of the coupler and should be done only in an emergency provided replacement couplers are available.

