

DDA40X

**OPERATOR'S
MANUAL**

Electro-Motive Division
La Grange, Illinois



DDA40X

OPERATOR'S

MANUAL



May, 1969

SERVICE DEPARTMENT

Electro-Motive Division

La Grange, Illinois



MARK OF EXCELLENCE

INTRODUCTION

This manual has been prepared to serve as a guide to railroad personnel engaged in the operation of the 6600 horsepower General Motors Model DDA40X turbocharged diesel-electric locomotive.

NOTICE

The data appearing in this manual is intended as a guide and as an aid in explaining the locomotive equipment used during operation. The information contained in the manual is based on data available when released for printing. Minor differences encountered in equipment are due to changes made after the manual was sent to press. These changes will be covered in subsequent editions of this manual.

The contents are divided into four sections as follows:

1. General Description - Provides general description of principal equipment components.
2. Cab Controls - Explains functions of cab control equipment used in operating the locomotive.
3. Operation - Outlines procedures for operation of the locomotive.
4. Trouble - Action in response to trouble.

A block of page numbers is allocated to each section, Section 1 starting with page 101, Section 2 with 201, and the others following in this manner. Figures are identified by section and sequence. For example: Fig. 2-3 is the third figure used in Section 2.

To obtain the most benefit from this manual, it is recommended that the sections be read in the sequence in which they appear.

Information pertaining to maintenance, adjustment, and testing is contained in the Locomotive Service Manual. Instructions for testing and maintenance of individual locomotive components will remain a part of the standard EMD Maintenance Instruction bulletin series, or will be included in an electrical component bench manual.

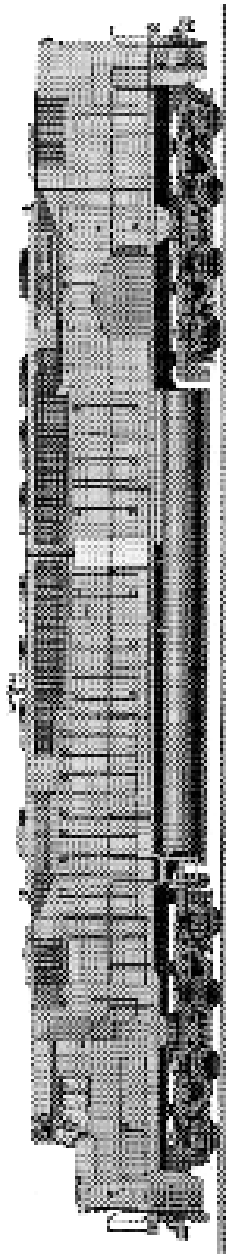

Fig. 0-1 - DDA40X Locomotive

INTRODUCTION

This manual has been prepared to serve as a guide to railroad personnel engaged in the operation of the 6600 horsepower General Motors Model DDA40X turbocharged diesel-electric locomotive.

The contents are divided into four sections as follows:

1. General Description - Provides general description of principal equipment components.
2. Cab Controls - Explains functions of cab control equipment used in operating the locomotive.
3. Operation - Outlines procedures for operation of the locomotive.
4. Trouble - Action in response to trouble.

A block of page numbers is allocated to each section, Section 1 starting with page 101, Section 2 with 201, and the others following in this manner. Figures are identified by section and sequence. For example: Fig. 2-3 is the third figure used in Section 2.

To obtain the most benefit from this manual, it is recommended that the sections be read in the sequence in which they appear. Information pertaining to maintenance, adjustment, and testing is contained in the Locomotive Service Manual. Instructions for testing and maintenance of individual locomotive components will remain a part of the standard EMD Maintenance Instruction bulletin series, or will be included in an electrical component bench manual.

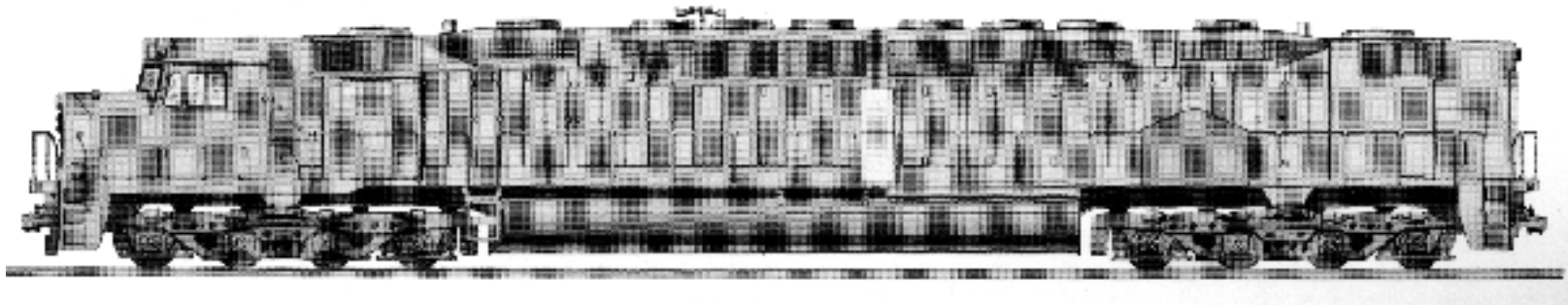

DDA40X Locomotive

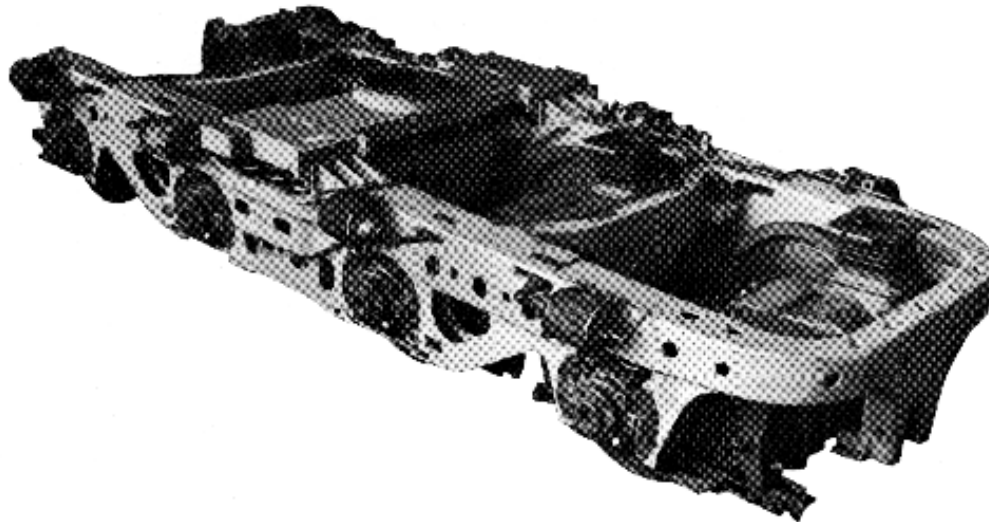

DDA40X Truck

GENERAL DATA

Model Designation	DDA40X
Locomotive Type	D-D (0880)
Locomotive Horsepower	6600
Maximum Loaded Weight On Rails	Approx. 540,000 lbs.
Supplies	
Fuel Capacity - (Usable Fuel)	8257 Gallons
Cooling Water	300 Gallons per Engine
Lubricating Oil, Gallons per Engine	Basic 243 - Increased Capacity 395
Gallons of oil between "Full" and "Low "	
on dip stick	Basic 47 - Increased Capacity 195
Sand	53 Cu. Ft.
Curve Negotiation	
Truck lateral at bolsters \pm 1-1/2" Nominal	
Minimum curve capability in multiple	
(Includes truck lateral).	295' radius - 19.4 degree curve
Minimum curve capability of unit coupled to 85	
car (Includes DD truck and car truck lateral)	359' radius - 16 degree curve
Designed to negotiate a No. 8 crossover when	
operated single, in multiple, or when coupled	
to box car with lateral.	

GENERAL DATA (Cont'd)

Major Dimensions	
Distance - Pulling face of front coupler to	
pulling face of rear coupler	98 Ft. 5 In.
Width over sand boxes	Approx. 10 Ft. 4 In.
Height over horn mounted at fan hatch	
(With 1/2 variable supplies, measured	
from top of straight and level track)	Approx. 17 Ft. 4 In.
Diesel Engines (2 per locomotive)	
Model	645E 3-A
Number of Cylinders	16
Compression Ratio	14.5:1
Cylinder Arrangement	45 degree "V"
Cylinder Bore And Stroke	9-1/6" x 10"
Operating Principle:	
2 Stroke Cycle, Turbocharger Aspirated Through Cylinder Wall Ports, Multi Valve Exhaust, Unit Fuel Injection, Water Cooled Cylinder Heads And Liners, Oil Cooled Floating Pistons, Isochronous Speed Governor, Separate Overspeed Trip, High Crankcase Pressure Protection, Ten Bearing Crankshaft, and Drop Forged Connecting Rods.	
Full Speed	950 RPM
Idle Speed	320 RPM

GENERAL DATA(Cont'd)

Main Generator Model (2 per locomotive)	AR12
Maximum Generator Voltage DC	1450
Rectifier Diode Voltage Class	2200/2800
Maximum Continuous Current	4800
Companion Alternator	D14
Nominal Voltage AC (950 RPM)	215
Number of Poles	16
Frequency At 950 RPM	126.5
Auxiliary Generator (2 per locomotive)	
Basic Rating.....	10KW
Voltage DC.....	74
Trucks	Two interchangeable 8-wheel assemblies. Fully flexible spring supported bolsters and journals with vertical and lateral friction dampers. Bolster centers 65 Ft. Truck wheel base 205-1/2 In.
Air Brakes	Clasp brakes operated by top mounted cylinders. Type 26L.

GENERAL DATA (Cont'd)

Traction Motors	
Model.....	D77X3
Number of motors	8
Current Rating - Max Continuous	1120 Amperes
Driving Wheels	8 Pair
Diameter.....	40 In.
Gearing	59:18
Full Horsepower - Low speed.....	28.3 MPH - Nominal
Full Horsepower - Max speed	82 MPH - Nominal
Minimum Continuous Speed (Full Throttle)	11.3 MPH
Gear Ratio Maximum Speed	
(Based on motor armature RPM)	90 MPH 59:18 Gearing 83 MPH 60:17 Gearing 77 MPH 61:16 Gearing 71 MPH 62:15 Gearing

TABLE OF CONTENTS

GENERAL DATA (Cont'd)

Air Compressor - Two Per Locomotive	
Type.....	2 Stage
Piston Pin Bearings	Roller Type
Number of Cylinders	3
Capacity (At 950 RPM)	Approx. 268 CFM
Cooling.....	Water
(Two Pass Intercooler)	
Lube Oil Capacity	10-1/2 Gal.
Storage Battery	
Number of Cells	32
Voltage.....	64
Rating (8 hour)	420 Ampere Hr.

	<u>Page</u>
SECTION 1 - GENERAL DESCRIPTION	101
Introduction	101
How The Locomotive Operates	102
SECTION 2 - ENGINE STARTING AND CAB CONTROLS	201
Introduction	201
Engine Starting Controls	201
Switch And Fuse Panel	203
Circuit Breaker Panels	208
Engine Control Panel	213
Locomotive Controller	224
Mechanical Interlocks On The Controller	236
Air Brake Equipment	237
Brake Equipment Positions	242
SECTION 3 - OPERATION	301
Introduction	301
Preparation For Service	301
Starting The Diesel Engines	307
Trailing Unit Cab Inspection	309
Trailing Unit No. 2 End Inspection	310
Starting Trailing Unit Diesel Engines	310
Placing Units On The Line	311
Precautions Before Moving Locomotives	312
Handling Light Locomotive	312
Draining Of Air Reservoirs And Strainers	313
Engine Air Box Drain	316
Cooling System And Cab Heater Drain Valves	316
Coupling Locomotive Units Together	318
Coupling Locomotive To Train	319

TABLE OF CONTENTS (Cont'd)

	<u>Page</u>
Pumping Up Air	319
Brake Pipe Leakage Test	320
Starting A Train	321
Accelerating A Train	324
Drag Duty Power Control	325
Operating Over Rail Crossing	325
Running Through Water	326
Wheel Slip Correction	326
Wheel Slip Light	327
Locomotive Speed Limit	328
Mixed Gear Ratio Operation	329
Dynamic Braking	329
Dynamic Brake Wheel Slide Control	332
Double Heading	333
Operation In Helper Service	334
Isolating A Unit	334
Changing Operating Ends	334
Stopping Engine	337
Securing Locomotive For Layover	338
Towing Locomotive In Train	339
Freezing Weather Precautions	340
 SECTION 4 - OPERATORS RESPONSE TO TROUBLE	 401
 Introduction	 401

SECTION 1

GENERAL DESCRIPTION

INTRODUCTION

The General Motors Model DDA40X locomotive, illustrated in Figs. 0-1 and 1-1, is designed for heavy duty mainline service. It is equipped with two separate and independent power units. Each power unit consists of a 3300 horsepower 16 cylinder turbocharged diesel engine directly connected to a main generator which delivers power to four traction motors, each of which is geared to an axle and pair of driving wheels. The four traction motors are located in a single truck. Power from the No. 1 engine is directed to the No. 1 truck and power from the No. 2 engine to the No. 2 truck.

The basic locomotive is arranged and equipped so that the short hood or cab end is considered the front or forward part of the unit. However, the locomotive operates equally well in either direction.

The locomotive may consist of one or more individual units, each of which is a completely functional power plant. When coupled together for multiple unit operation, all can be simultaneously controlled from a single set of controls located in the cab of the lead unit. This is accomplished through jumper cables connected between the units.

The general arrangement of equipment used on the locomotive is shown in Fig. 1-1. Each of the more important equipment components is numbered and identified in this illustration.

HOW THE LOCOMOTIVE OPERATES

The DDA40X locomotive consists of two independent power plants. The No. 1 power plant delivers power to the four motors in the No. 1 truck. The No. 2 power plant delivers power to the four motors in the No. 2 truck. Each power plant receives signals from the locomotive operators station just as trailing units in a consist do.

The following descriptive paragraphs approach a single power plant independently and are so worded.

1. The fuel pump is driven by an electric motor which, for fuel priming, uses current from the storage battery. Once the engine is started and running, the fuel pump motor uses current directly from the auxiliary generator. The fuel pump transfers fuel from the fuel tank under the locomotive through a suction strainer, a primary filter, and engine mounted filters to the engine injectors. Racks on the injectors are positioned by the engine governor to control the amount of fuel injected into the engine cylinders.
2. The diesel engine is started by means of two parallel connected 64-volt cranking motors that engage the engine flywheel ring gear when starting current is applied. The storage battery supplies electric current to engage the starting pinions and rotate the cranking motors.
3. When the engine is running, it supplies mechanical power through shafts and couplings to directly drive three electrical generators, the air compressor, the motor and generator blowers, and engine mounted lube oil and cooling water pumps.

4. The main traction alternator supplies high voltage AC to a power rectifier assembly which then delivers high voltage DC to the traction motors for locomotive pulling power.
5. The companion alternating current generator furnishes power to the static exciter, various transducers, various control circuit modules, the three radiator cooling fans, and the inertial separator blower motor.
6. The auxiliary generator charges the storage battery and supplies low voltage direct current for control, lighting, and heating circuits.
7. By means of cab controls, low voltage circuits are established to actuate the engine governor and the switchgear in electrical cabinets. This switchgear controls generator excitation and distribution of power.
8. Four traction motors are located in each truck. Each traction motor is directly geared to an axle and pair of driving wheels.
9. The throttle electrically controls speed and power by actuating a governor mounted on the engine and by tying the response of the locomotive power control system to the throttle. The main generator converts the engine's mechanical power to electrical power, which is then distributed to the traction motors through circuits established by various switchgear components in the electrical cabinet.
10. At locomotive start the throttle controls electrical devices that provide rapid power response at a level consistent with smoothly controlled starting.

DESCRIPTION

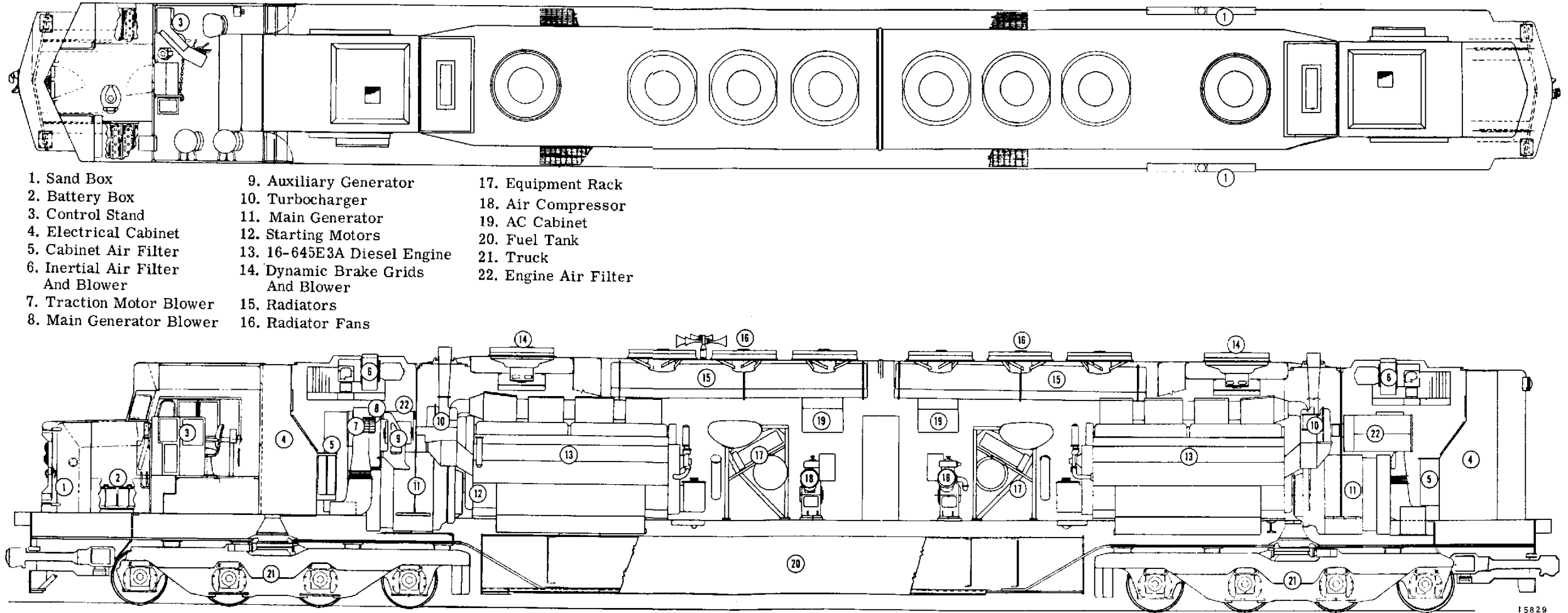

- | | | |
|--------------------------------------|---------------------------------------|-----------------------|
| 1. Sand Box | 9. Auxiliary Generator | 17. Equipment Rack |
| 2. Battery Box | 10. Turbocharger | 18. Air Compressor |
| 3. Control Stand | 11. Main Generator | 19. AC Cabinet |
| 4. Electrical Cabinet | 12. Starting Motors | 20. Fuel Tank |
| 5. Cabinet Air Filter | 13. 16-645E3A Diesel Engine | 21. Truck |
| 6. Inertial Air Filter
And Blower | 14. Dynamic Brake Grids
And Blower | 22. Engine Air Filter |
| 7. Traction Motor Blower | 15. Radiators | |
| 8. Main Generator Blower | 16. Radiator Fans | |

Fig. 1-1 – General Arrangement
DDA40X Locomotive

DESCRIPTION

11. During heavy-drag operation, control circuits allow operation at full power until traction motors become hot. After the motors have become hot power is controlled at optimum levels that allow the locomotive to operate at minimum continuous speed consistent with less powerful locomotives that may be in the consist. The control also allows high current short-time power at an optimum level.
12. At moderate and high operating speeds a load regulator operates to maintain power output at the specific level called for by throttle position. This prevents the engine from being overloaded or underloaded.
13. The air compressor supplies, to the reservoirs, air under pressure used primarily for the air brakes. The air brakes are controlled by the operator through suitable equipment in the cab.
14. Except for manual operation of cab controls, the locomotive operation is completely automatic. Various alarms and safety devices will alert the operator should any operating difficulties occur.

SECTION 2

ENGINE STARTING AND CAB CONTROLS

INTRODUCTION

A switch for fuel priming and engine cranking is located at the equipment rack for each engine. All other basic control equipment used during locomotive operation is at the following locations.

1. Cabinet mounted No. 1 and No. 2 switch and fuse panels.
2. Cabinet mounted No. 1 and No. 2 engine control panels.
3. Cabinet mounted No. 1 and No. 2 circuit breaker panels.
4. Locomotive control stand.

The operating panels for the No. 1 engine are at the front of the No. 1 main electrical cabinet, which faces the inside of the operating cab. The operating panels for the No. 2 engine are at the left walkway side of the No. 2 cabinet and are accessible through a latched door.

ENGINE STARTING CONTROLS, Fig. 2-2

Fuel Prime and Engine Start Switch

This switch, located on the equipment rack in the engineroom, is a three-position rotary switch used for fuel priming and engine starting. Before attempting to start the diesel engine, the isolation switch in the locomotive cab must be placed in the START position. The rotary switch must then be placed in the FUEL PRIME position and held there for 10 to 15 seconds to operate the fuel pump. The layshaft lever must then be positioned

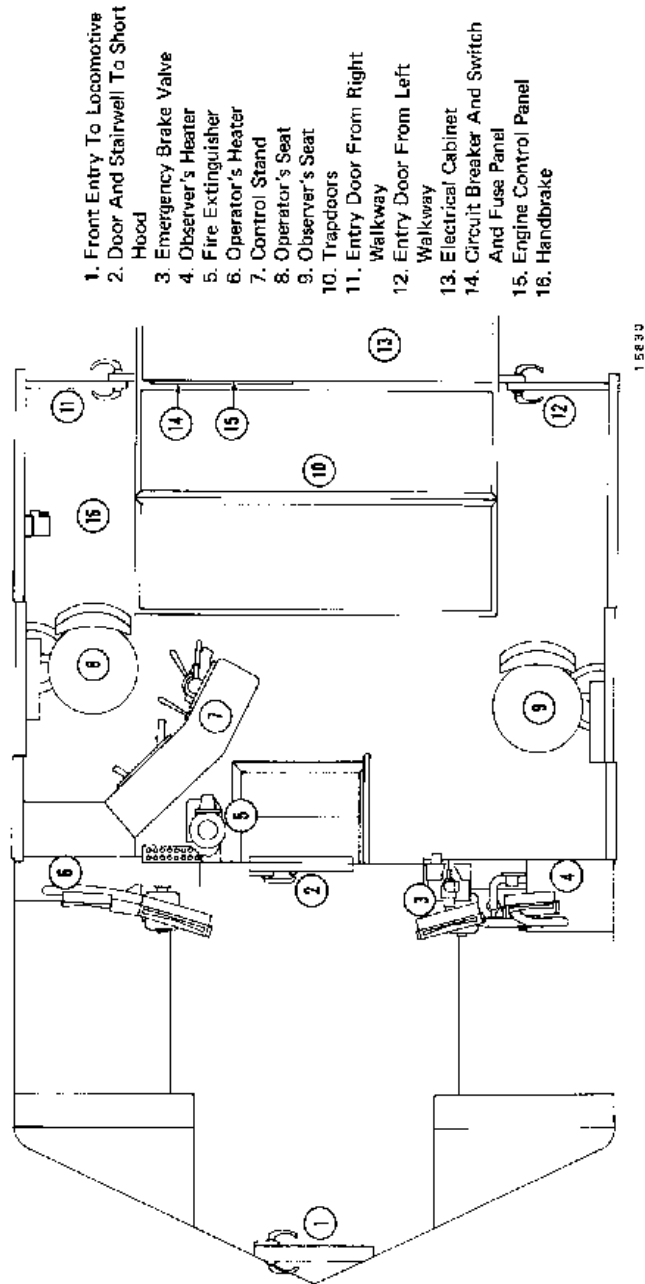

Fig. 2-1 -- DDA40X Cab Arrangement

1. Front Entry To Locomotive Hood
2. Door And Stairwell To Short Hood
3. Emergency Brake Valve
4. Observer's Heater
5. Fire Extinguisher
6. Operator's Heater
7. Control Stand
8. Operator's Seat
9. Observer's Seat
10. Trapdoors
11. Entry Door From Right Walkway
12. Entry Door From Left Walkway
13. Electrical Cabinet
14. Circuit Breaker And Switch
15. Engine Control Panel And Fuse Panel
16. Handbrake

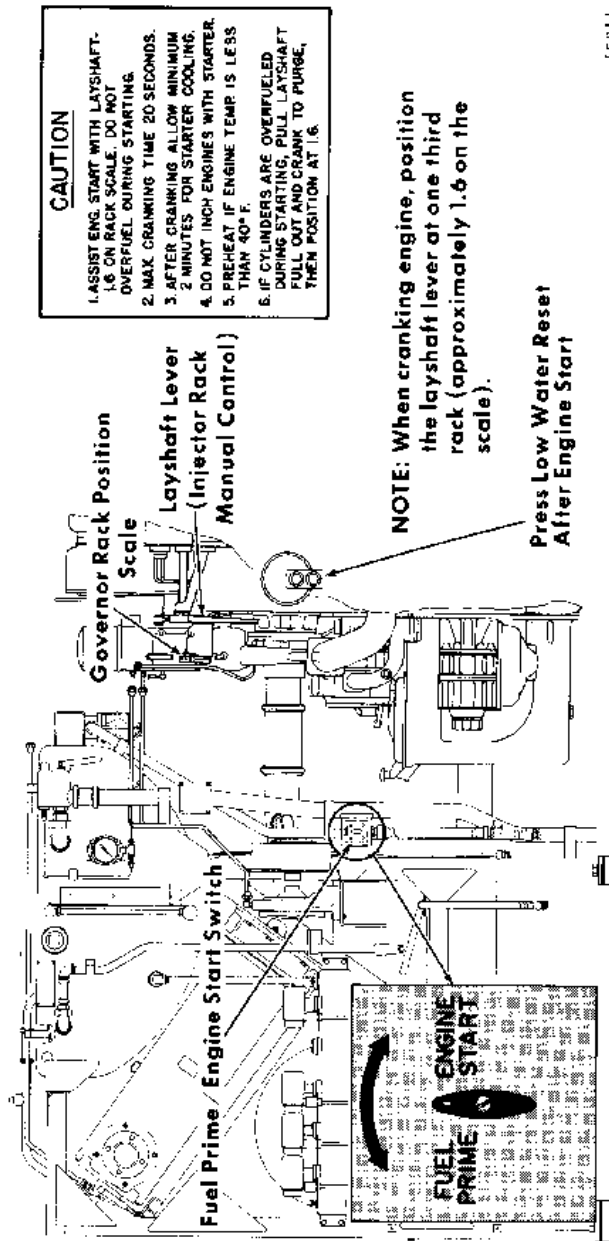

Fig. 2-2 -- Engine Starting Controls

and the rotary switch placed in the ENGINE START position and held (for no longer than 20 seconds) until the engine starts.

Layshaft Lever

This engine mounted hand operated lever operates the injector racks. It is used to position the injector racks during engine cranking, thereby providing an immediate supply of fuel to the cylinders.

Low Water Reset Pushbutton

Check the low water reset pushbutton after every engine start. Press to reset if necessary.

SWITCH AND FUSE PANEL

The panel shown in Fig. 2-3 is located within the electrical cabinet that forms the rear wall of the locomotive cab. Its position is directly below the engine control panel which is located in the upper left hand corner of the electrical cabinet.

D14 Alternator Field 60-Ampere Fuse

The D14 alternator receives its excitation through a pair of slip rings connected to the low voltage DC auxiliary generator output. To protect these windings, a 60-ampere fuse is provided in the excitation circuit. This fuse must be good and in place at all times during locomotive operation.

In the event that the fuse is blown, D14 alternator excitation and resulting power output will cease, setting off the no power alarm, and reducing the engine speed to idle.

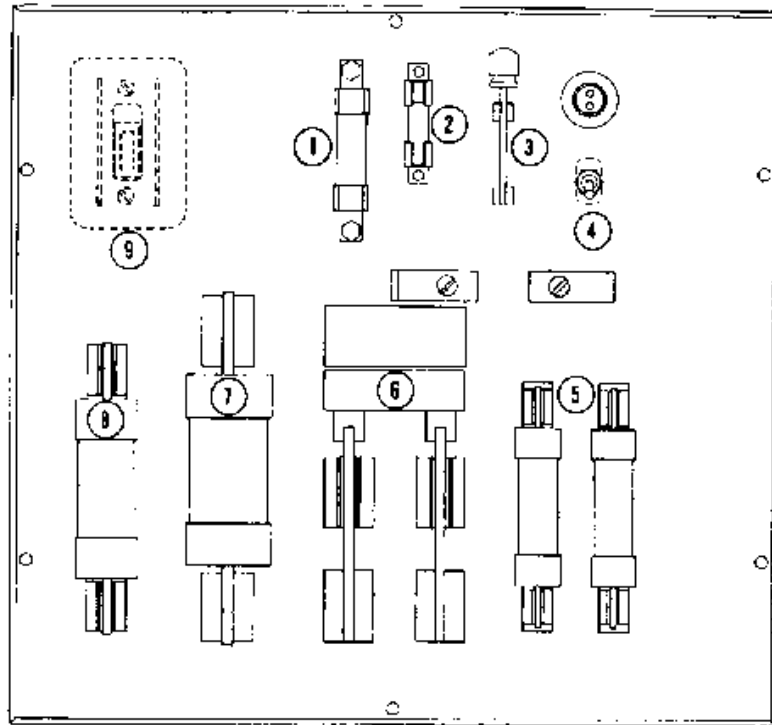

1. D14 Alternator Field 60 Amp. Fuse
2. Auxiliary Generator Field 30 Amp. Fuse
3. Basic Ground Relay Cutout Switch
4. Fuse Test Equipment
5. Main Generator Field 100 Amp. Fuses
6. Main Battery Knife Switch
7. Starting 800 Amp. Fuse
8. Auxiliary Generator 150 Amp. Fuse
- *9. Ground Relay Cutout Switch (Special)

*Indicates Extra Modification

Fig. 2-3 - No. 1 Switch And Fuse Panel

Auxiliary Generator Field 30-Ampere Fuse

The field excitation circuit of the auxiliary generator is protected by a 30-ampere fuse. This fuse must be good and in place at all times during locomotive operation. In the event that this fuse is burned out, it stops auxiliary generator output to the low voltage system and also stops fuel pump operation. An alternator failure (no power) alarm would then occur. The engine will go to idle speed and then stop from lack of fuel.

Ground Relay Cutout Switch

The purpose of the ground relay cutout switch is to eliminate the ground protective relay from the locomotive circuits during certain shop maintenance inspections. It **MUST ALWAYS BE KEPT CLOSED** in normal operation, otherwise the protection offered by the ground relay will be nullified and possible serious equipment damage could occur. It may be opened, however, in the event of extreme emergency upon receipt of definite instruction to that effect from responsible officer of the railroad.

On special order a toggle type ground relay cutout switch may be provided. This multiple pole switch prevents excitation of the main generator and speedup of the diesel engine when the ground relay is cut out.

Fuse Test Equipment

To facilitate the testing of fuses, a pair of fuse test blocks, a test light and a test light toggle switch are installed on the fuse panel. Fuses may be readily tested as follows. First, move the toggle switch to the ON position to make sure the fuse test light

is not burned out. Extinguish the light by moving the toggle switch to the OFF position. Place a fuse across the test blocks so that the metal ends of the fuse are in firm contact with the blocks. If the fuse is good, the light will come on. If the fuse is burned out, the light will not come on and a new fuse is required.

It is always advisable to test fuses before installing them in their circuits. Always isolate the circuits in question by opening their switches before changing or replacing fuses.

Auxiliary Generator Fuse

This fuse connects the auxiliary generator to the low voltage system. It protects against excessive current demands. A 150 ampere fuse is installed for the basic auxiliary generator and a 250 or 350 ampere fuse is installed for the heavy duty generator. In the event that the fuse is burned out, it stops auxiliary generator output to the low voltage system and also stops fuel pump operation. An alternator failure (no power) alarm would then occur. The engine will go to idle speed and then stop from lack of fuel.

CAUTION: The 250 and 350 ampere fuses are of the same physical size as the starting 800 ampere fuse. Do not interchange the fuses.

Starting 800-Ampere Fuse

The starting fuse is in use only during the period that the diesel engine is actually being started. At this time, battery current flows through the fuse and starting contactor to the cranking motors.

Although this fuse should be in good condition and always left in place, it has no effect on locomotive operation other than for engine starting. A defective fuse can be detected when attempting to start the engine, since at that time (even though the starting contactors close) the cranking circuit is open.

CAUTION: The 800 ampere starting fuse is the same physical size as the 400 ampere starting fuse used on many locomotive models. Be careful not to interchange the fuses.

If doubt exists about the fuse rating, the fuse may be opened and checked. The 800 ampere fuse has a double fusible link, while the 400 ampere fuse has a single link.

Main Battery Knife Switch

The large double-pole single-throw knife switch at the lower portion of the fuse panel is the main battery switch. It is used to connect the battery to the locomotive low voltage system and should be kept closed at all times during operation.

If this switch were left open, the fuel pump could not be started, the lights would not function and the engine could not be started. If the switch is opened after the engine has been started, the auxiliary generator will continue to supply the low voltage needs, but the batteries will not receive charge.

This switch may be opened during certain shop maintenance procedures and in instances where the engine is shut down and the locomotive taken out of service for an extended layover. This will prevent the battery from being discharged in the event the

lights or other low voltage devices are inadvertently left operating during the layover. Particular attention should be given when a notation at the switch cautions against opening the switch immediately after engine shutdown. At least 35 minutes should be allowed following engine shutdown before this switch is opened after load operation at or above throttle position No. 3. That is, cool down time for the turbocharger bearings can be considered to accumulate below throttle position No. 3 even though the 35 minute timing of the turbocharger auxiliary lube oil pump begins at engine shutdown.

AR12 Generator Field 100-Ampere Fuses

The AR12 generator receives its excitation through a pair of slip rings connected to the D14 alternator output through a controlled rectifier. The fuses are provided to protect the controlled rectifier, the generator field windings, and various control devices and circuits that use the D14 alternator as a power source.

When a single generator field fuse blows, all locomotive power is lost, the alarm bell rings, and the no power light on the engine control panel comes on. The blown fuse must be replaced before operation can continue.

CIRCUIT BREAKER PANELS Fig. 2-4

The No. 1 circuit breaker panel is located in the operator's cab and is positioned to the right of the switch and fuse panel and directly under the engine control panel. The No. 2 circuit breaker panel is at the side of the No. 2 electrical cabinet at the locomotive walkway. Access to the No. 2 panel is provided through a latched door. All breakers open both the positive and negative side of the circuit to provide complete isolation. The circuit breaker panels contain the following:

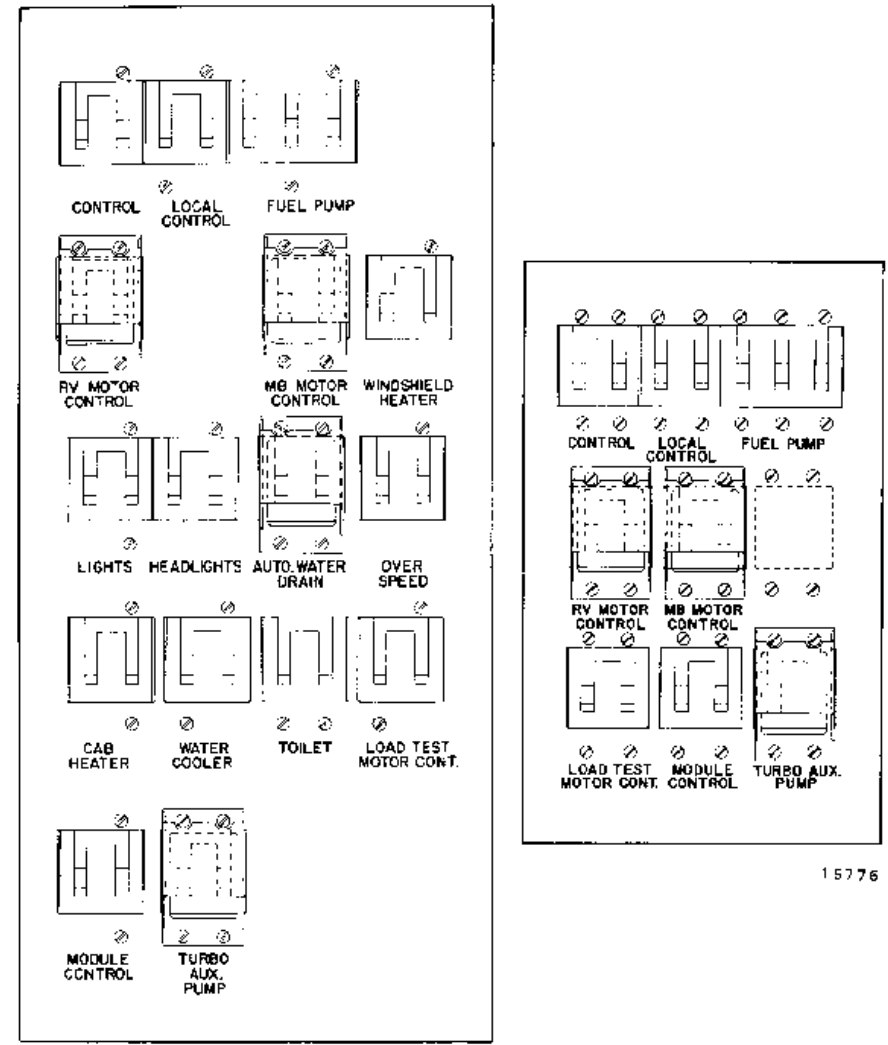

Fig. 2-4 - Circuit Breaker Panels No. 1 And No. 2

Control 40-Ampere Circuit Breaker

This circuit breaker must be in the ON position before locomotive operation is possible. It sets up the fuel pump and control circuits for engine starting. Once the engine is running, power is supplied through this breaker from the auxiliary generator to maintain operating control.

Local Control 30-Ampere Circuit Breaker

This circuit breaker must be in the ON position before operation of the locomotive is possible. During operation it establishes "local" power from the auxiliary generator to operate heavy duty switchgear, and various control devices.

Fuel Pump Circuit Breaker

This three pole circuit breaker protects the fuel pump motor circuit. It must be on for normal locomotive operation.

RV Motor Control Circuit Breaker

This double pole breaker is located in the feed to the operating motor of the multi-pole, motor operated, ganged switches that control the direction of current flow through the traction motor fields and thus control the direction of locomotive travel. Since control power is required to move the RV transfer switchgear from any position to any other position, the RV breaker must be closed for power transfer to take place. An open RV breaker does not prevent switchgear from already being in position to properly conduct traction motor current, but interlocking prevents an operating setup in conflict with transfer switch position. In addition, the circuit breaker is guarded to prevent accidental movement.

MB Motor Control Circuit Breaker

On units equipped with dynamic brakes, this double pole breaker is located in the feed to the operating motor of the multi-pole, motor operated, ganged switches that control the motor field and armature connections for either dynamic braking or power operation. Since control power is required to move the MB transfer switchgear from any position to any other position, the MB breaker must be closed for power transfer to take place. An open MB breaker does not prevent switchgear from already being in position to properly conduct motor or braking current, but interlocking prevents an operating setup in conflict with transfer switch position. In addition, the circuit breaker is guarded to prevent accidental movement.

Windshield Heater Circuit Breaker

As a special extra, a thin transparent metallic coating is vacuum sprayed on an inner surface of the laminated windshield glass. Electrical connections are made to the coating. When electric power is applied, the resistance of the coating causes heat to be given off at the rate of 1 watt per square inch to keep the window surface free of frost or ice. The breaker protects the window heater circuit.

Lights Circuit Breaker

This breaker must be ON to supply power for the individual switches provided for number, class, platform, cabinet, hood, controller, and ground and gauge lights.

Headlights Circuit Breaker

This breaker protects the headlights circuit and its trainlined circuit. It must be onto provide current to the front headlight circuit and through the trainline to the light at the rear of a consist.

Automatic Water Drain Circuit Breaker

On units equipped for automatic water drain, when water temperature at a thermostatic switch in cab heater piping approaches freezing, automatic drain valves are energized if the engine is shut down or if the no AC voltage relay NVR. is dropped out for any reason.

CAUTION: Cab heater piping can become cold even with the engine running if heater supply, return, or cab shutoff valve is closed.

Overspeed Circuit Breaker

Train overspeed, sensed by the locomotive speed recording instrument, brings about a penalty application of the brakes and operation of a pneumatic control switch to drop locomotive power. The overspeed breaker protects overspeed magnet valve circuit.

Cab Heater Circuit Breaker

Protects the circuit to the cab heater blower motors.

Water Cooler Circuit Breaker

When an electric water cooler is provided, this breaker protects the circuit.

Toilet Circuit Breaker

When a flush type toilet is provided, an electric immersion heater prevents freeze up of flush tank water. This breaker protects the circuit.

Load Test Motor Control Circuit Breaker

On units equipped with the special extra provision for automatic loading on the locomotive's own dynamic braking grids, this circuit breaker protects the circuit to the load test transfer switchgear. It is recommended that this circuit breaker remain in the ON position at all times. This will help prevent the possibility of accidentally loading the unit on its grids during consist operation on the road.

CAUTION: Do not load the unit on its own dynamic braking grids during movement on a track. The locomotive must be at standstill during load testing.

Module Control Circuit Breaker

Electrical control circuits are assembled on plug-in module cards to facilitate maintenance. Local control power is supplied to many of the circuit boards. This breaker protects the local control circuit to the boards.

Turbo Auxiliary Pump Circuit Breaker

This circuit breaker must be in the ON position to start the engine and operate the turbocharger auxiliary lube oil pump. It must remain in the ON position to provide auxiliary lubrication to the turbocharger at engine start and after the engine is shut down. A guard is provided over this breaker to prevent accidental movement to the OFF position.

ENGINE CONTROL PANEL

An engine control panel, Fig. 2-5 and 2-6, is provided for each engine section of the DDA40X locomotive. The panels contain switches and alarm lights along with a battery charging indica-

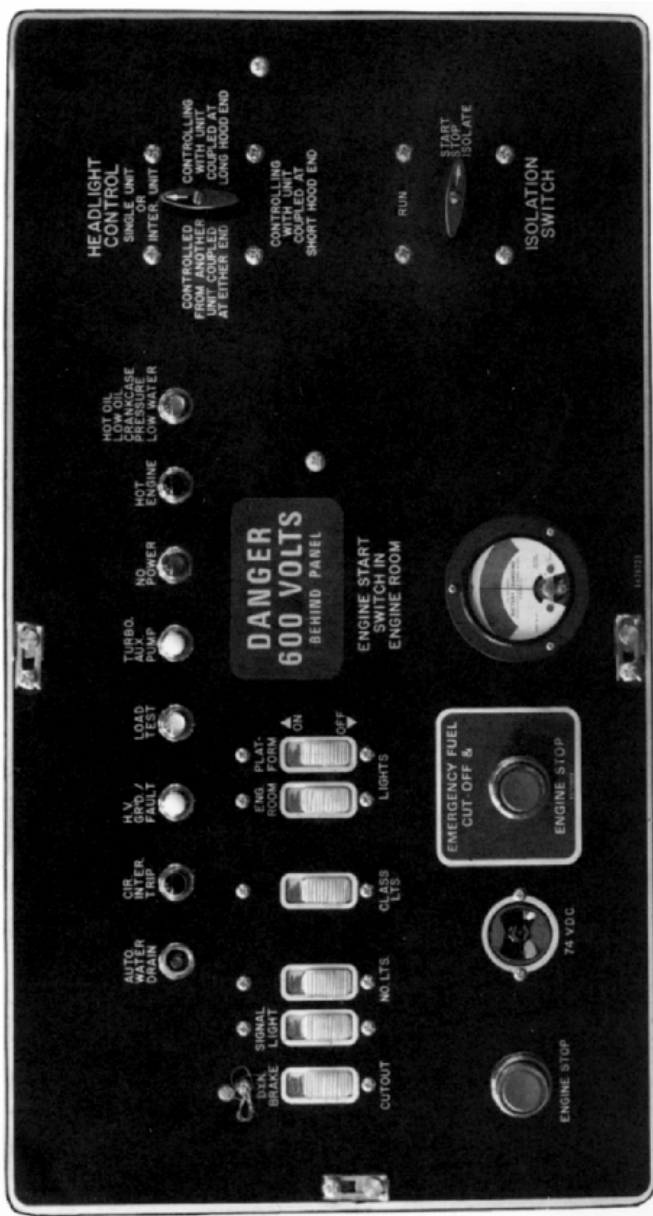

Fig. 2-5 — No. 1 Engine Control Panel

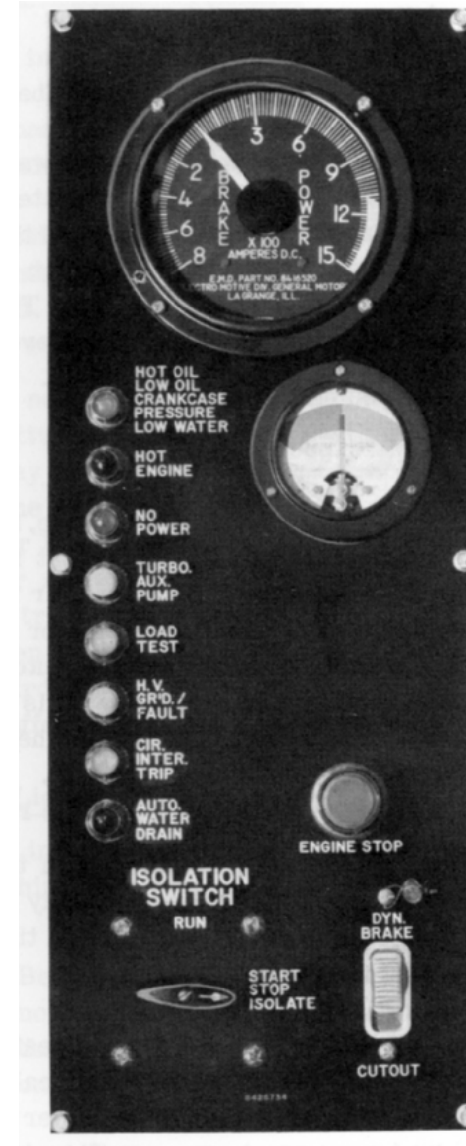

Fig. 2-6 - No. 2 Engine Control Panel

or. A brief description of individual function follows.

Automatic Water Drain Light

On locomotive units equipped for automatic water drain, a thermostat in the cooling system senses water temperature. After an engine has been shutdown and the coolant nears freezing temperature, this thermostat energizes magnet valves that open to drain and vent. The coolant is drained from the system. Interlocking prevents accidental drainage when the engine is operating.

Circuit Interrupter Tripped Light

This light comes on when immediate response, heavy duty interrupters snap open to isolate motors at flashover. Power is dropped for a time while ionized air is cleared from the interrupter area and flashed motor is vented. After about 1/2 minute a timing device automatically closes the interrupter contacts and power is reapplied without action by the locomotive operator. The light goes out and operation may continue normally. A routine report should be made out as required by the railroad.

Often the ground relay will trip along with the circuit interrupter. If this occurs, the ground relay will reset automatically, either immediately or after a time delay, depending upon equipment used.

WARNING: The circuit interrupters are located at the lower portion of the main electrical cabinets. When an interrupter trips under power, a loud sharp report occurs. This is normal. The interrupters reset automatically after about 1/2 minute.

High Voltage Ground/Fault Light

This light indicates that an electrical path to ground has occurred, or that a group of five diodes in the main generator has failed. When the light comes on and the alarm sounds, the operator should wait 10 seconds, then press the ground reset button located on the control stand, Fig. 2-7. Power will then reapply unless a circuit interrupter has tripped in conjunction with the ground/fault. In such case, power will reapply when the interrupter resets.

If there is no ground reset button on the control stand, the locomotive will be equipped with special automatic ground relay reset, and the operator need take no action to reset the relay. Such automatic reset devices are equipped for lockout, and automatic reset will be nullified after either a specific number of trips or after a given number of trips with a time period. On the basic locomotive, when the high voltage ground/fault alarm occurs for the third time after using the ground reset button twice, the affected unit should be isolated.

Load Test Light

This light indicates the load test knife switch that is located within the electrical cabinet is in the load test position.

CAUTION: Before returning the load test switch to the normal operating position, make certain that the load test motor control circuit breaker on units so equipped is in the ON position.

Turbocharger Auxiliary Pump Motor Light

This light will come on as soon as the main battery switch and turbo lube pump circuit breaker are closed.

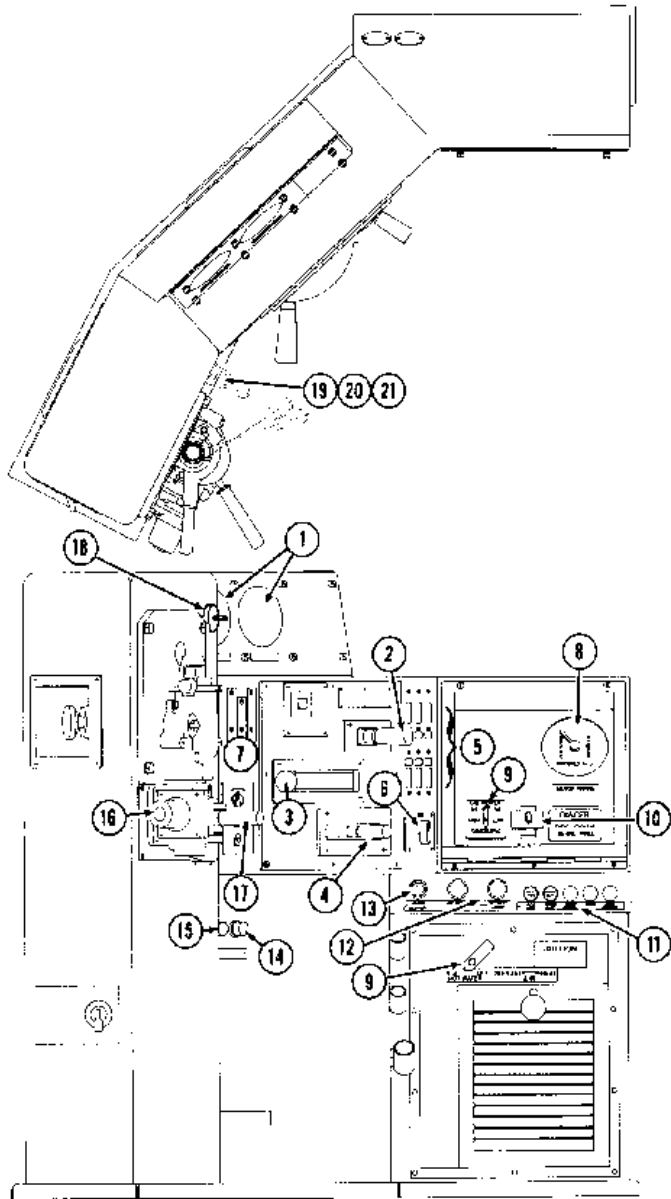

Fig. 2-7 - Locomotive Controller

1. Air Gauges
2. Selector Lever
3. Throttle Lever
4. Reverser Lever
5. Operating Switches
6. Headlight Dimming Switch
7. Miscellaneous Switches
8. Load Current Meter
9. Cab Heater Controls
- *10. Windshield Heater Switch
11. Indicating Lights
12. Gauge Light Dimmers
13. Alarm Silence Button
14. Ground Reset Button
15. Attendant Call Button
16. Air Brake Controls
17. Miscellaneous Operating Switches
18. Air Horn Operator
19. Sand No. 1 Truck Switch
20. Sanding Lever
21. Bell Ringer

*Special Equipment

It indicates that the turbocharger auxiliary lube oil pump is supplying lube oil to the turbocharger. It will remain on for approximately 35 minutes after the main battery switch is closed. When the fuel prime engine start switch is operated after the 35 minute period, the time cycle is again re-established and the light remains on for another 35 minutes.

The light will also come on and remain on for approximately 35 minutes after the engine is stopped to provide an indication that the auxiliary lube oil pump is supplying oil to cool the turbocharger bearings.

No Power Alarm Light

The no power light (blue) will come on, and the alarm bell will ring any time the no AC voltage relay (NVR) opens with the isolation switch in RUN position and the ER switch in ON position (on special order the locomotive may not be equipped with an ER switch).

The light will come on if -

1. A main generator field fuse blows.
2. D14 failure occurs.
3. The engine stops.

Hot Engine Light

The hot engine light operates along with the alarm bell to warn the operator that engine cooling water has reached an excessive temperature. When the hot engine light comes on engine speed and power are reduced to a lower level to hasten engine cooling and prevent possible damage.

Hot Oil/Low Oil/Crankcase (Oil Pan) Pressure/Low Water Light

A mechanism to detect low engine lubricating oil pressure is built into the engine governor. This mechanism is actuated by true oil pressure failure or by dumping oil from the engine oil line leading to the governor. In either event a small button will pop out of the governor body, indicating that the mechanism has tripped the low oil alarm switch. The amber light on the engine control panel will come on to indicate that the low oil mechanism has tripped.

When an alarm occurs it is necessary to determine whether the crankcase pressure - low water detector has tripped to dump engine oil from the line leading to the governor, or whether a true oil failure has occurred. This can be determined by checking the crankcase pressure - low water detecting device' Fig. 3-2, for protruding reset buttons. A protruding upper button indicates excessive oil pan pressure; a protruding lower button indicates low water.

WARNING: When it is determined that the crankcase pressure detector has tripped, make no further engine room inspections. Do not attempt to restart the engine. Isolate the unit and drain the cooling system in accordance with railroad regulations.

If the low water or crankcase detectors have not tripped, and the oil and water levels are satisfactory, the hot oil valve (on units so equipped) may have opened. This valve will reset automatically when oil temperature goes down, and the engine may be restarted after a cool down period; however, power operation under these circumstances is not recommended until maintenance personnel have checked the engine and systems.

CAUTION: If the engine is restarted, shut it down immediately if oil pressure at idle is less than 15 psi.

Miscellaneous Switches

Switches are included in circuits for various lights and devices on the locomotive. The switches are closed as desired to operate the class lights, the number lights, the engine room lights, and the platform lights.

On units equipped with dynamic brakes, a lock-wired cutout switch is provided to disable the dynamic brakes on that particular unit should a fault occur.

Headlight Control Switch

The twin sealed-beam front and rear headlights are controlled by the front and rear headlight switches on the locomotive control panel. A dimming switch is mounted on the right side of the controller. Before these switches will function, the 30-ampere headlight circuit breaker must be placed ON.

On locomotives equipped for multiple unit operation, a remote headlight control switch is mounted on the engine control panel. This remote headlight control switch provides for operation of the rear unit headlight from the lead unit. The switch positions are set on each unit as follows:

1. On Lead Unit

If only a single locomotive unit is being used, place the switch in SINGLE UNIT position.

In multiple unit service, if trailing units are coupled to the No. 2 or long hood end of the lead unit, place the switch in the CONTROLLING - COUPLED AT LONG HOOD END position.

In multiple unit service, if trailing units are coupled to the No. 1 or short hood end of the lead unit, place switch in CONTROLLING - COUPLED AT SHORT HOOD END position.

2. On Intermediate Units

On units operating in between other units in a multiple unit consist, place the switch in the SINGLE UNIT position.

3. On Trailing Units

The last unit in a multiple unit consist should have the headlight control switch placed in the CONTROLLED - COUPLED AT EITHER END position.

Engine Stop Pushbutton

An engine stop pushbutton is located at each engine control panel. When one of the buttons is pressed, the engine at that end of the locomotive unit will immediately shut down.

Emergency Fuel Cutoff Pushbutton

An emergency fuel cutoff pushbutton is located at No. 1 engine control panel and at each fuel filler opening. When any one of the buttons is pressed, both engines on the locomotive will immediately shut down.

The throttle lever in the lead unit of a consist can be used to shut down all units in the consist.

Isolation Switch

The isolation switch has two positions, one labeled START/STOP/ISOLATE, the other labeled RUN. The functions of these two positions are as follows:

1. START/STOP/ISOLATE Position

The isolation switch is placed in this position whenever the diesel engine is to be started. The start switch is effective only when the isolation switch is in this position.

The START position is also used to isolate the unit, and when isolated the unit will not develop power or respond to the controls. In this event the engine will run at idle speed regardless of throttle position. This position will also silence the alarm bell in the event of an excitation limit, a ground relay, a no power, or a low lube oil alarm. It will not, however, stop the alarm in the event of a hot engine.

If the locomotive is equipped with remote traction motor cutout switch, the isolation switch must be placed in the ISOLATE position before the cutout switch can be operated.

2. RUN Position

After the engine has been started, the unit can be placed "on the line" by moving the isolation switch to the RUN position. The unit will then respond to control and will develop power in normal operation.

LOCOMOTIVE CONTROLLER

The locomotive controller is shown in Fig. 2-7. It contains the switches, gauges, and operating levers used by the operator during operation of the locomotive. The individual components of the controller are described, together with their functions, in the following paragraphs.

Air Gauges

These gauges indicate various pressures concerned with operation of the locomotive and train brakes.

Selector Lever

The controller is equipped with a selector lever, Fig. 2-8, in instances where the locomotive unit is equipped with dynamic brakes or when it is necessary to manually control transition on trailing units not equipped for automatic transition. On units so equipped, this lever serves to establish proper circuits for either of these functions. The position of the lever is indicated in the lower of the two illuminated windows located at the upper left corner of the controller front panel. The lever is spring loaded so

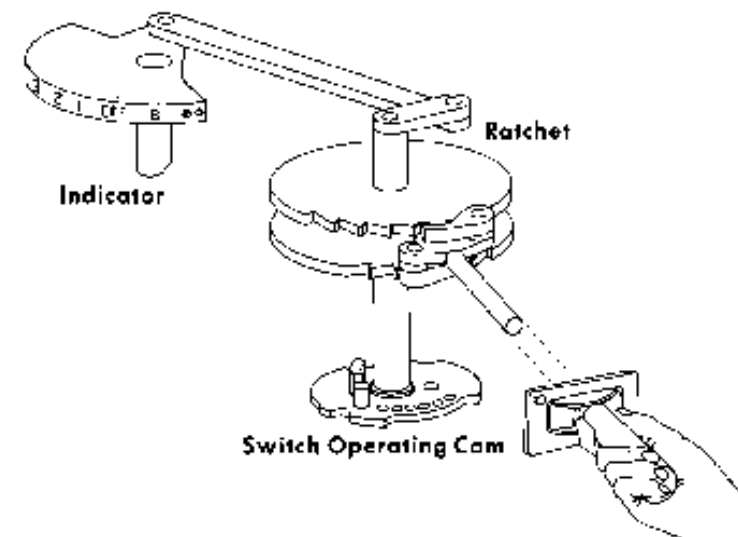

Fig. 2-8 - Selector Lever

that movement all the way in one direction will index the selector cam one notch only in that direction. It must be allowed to return to center position before indexing again in either direction. When the selector lever is indexed to the B or braking position, the motor-braking transfer switches operate. In the braking position the throttle lever moves freely (without notching) to control a braking rheostat and dynamic braking strength.

When the lever is moved to the center or OFF position, all circuits are open. This position is used for locking the controller in unattended or trailing units.

For operation under power, the lever would be indexed to the No. 1 position. Succeeding positions such as Nos. 2, 3, and 4 would be used only when it is necessary to cause transition on any non-automatic trailing units operating in the locomotive consist.

Throttle Lever

The throttle lever actuates switches within the controller to establish low voltage electrical circuits to the engine governor for purposes of controlling engine speed. The throttle has ten positions namely, STOP, IDLE and running speeds 1 through 8 as shown in Fig. 2-9. Each of these positions is shown in the illuminated indicator in the upper left hand corner of the controller. To stop all engines, the throttle lever is pulled out away from the controller and then moved one step beyond IDLE to the STOP position. The IDLE position is as far forward as the throttle lever can be moved without pulling it away from the controller.

Each running notch on the throttle increases the engine speed an average of 90 RPM starting at 320 RPM at IDLE and Run 1 and going to 950 RPM at full throttle.

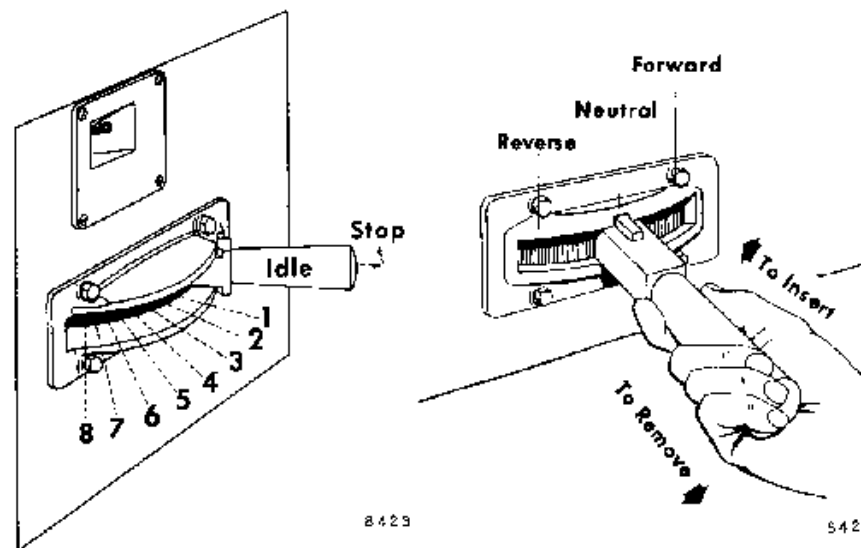

Fig. 2-9 - Throttle Lever

Fig. 2-10 - Reverse Lever

When operating in dynamic braking (selector lever in "B") the throttle lever serves as a braking handle. It moves freely without notching to control dynamic braking.

Reverse Lever

The reverse lever, Fig. 2-10, has three positions: forward, neutral and reverse. The direction in which the locomotive moves is controlled by movement of this lever to the forward or reverse position. With the lever in neutral, no power will be developed if the throttle is opened. The reverse lever should be moved ONLY when the locomotive is standing still.

The reverse lever can be removed from the controller only when the lever is in neutral position, the throttle is in IDLE and the

selector lever is in OFF. Removal of the reverse lever locks the operating controls in the controller. The reverse lever should be removed from the controllers in all but the lead unit of a multiple unit locomotive consist.

Operating Switches

A group of switches is located along the front face of the controller, each identified by a name plate indicating switch function. The switches are in the ON position when moved upward.

Before the engine is to be started, the control and fuel pump switch must be placed ON. To obtain power from the locomotive, the generator field switch must be ON. To obtain control of engine speed, the engine run switch must be ON. These three important switches are grouped at the right side of the controller. They must be placed in the OFF position on controllers of trailing units.

On special order the functions of the operating switches may be modified. For example, the engine run switch may be eliminated, and a fuel pump switch substituted. In such case the fuel pump function is removed from the control and fuel pump switch. The isolation switch must then be used to provide secondary control of engine speed.

Other switches control sanding, attendant call, and various lights. They are placed on as needed.

Horn Lever Or Switch

On the basic locomotive the air horn valve and lever are located at the upper left side of the controller. This lever operates the unit's air horn.

On special order a wobble stick type of horn switch may be employed to activate trainlined air horn magnet valves. All horns connected to the trainline operate when the lever is operated.

Sanding Switches

1. SANDING NO. 1 TRUCK Toggle Switch

The signal from this switch is not trainlined. The switch provides sand to only the number 1 axle of the lead unit of a consist. This method of sanding dresses the rail and is adequate for most conditions.

2. SAND Lever Switch

When the sanding switch lever is operated, electrical energy is directed through interlocks of reverser switchgear to operate either the forward or reverse sanding magnet valves in all units of a consist. The basic switch may be operated in any direction for correct sanding and is non-latching. A directional sanding switch may be provided as an optional extra, and the switch may be latching if requested by the railroad.

Electrically controlled sanding is the basic system used, but since the locomotive may be operated in multiple with older units that are equipped only for pneumatic control of sanding, trainlined pneumatic control of sanding maybe provided as an optional extra in addition to electrical control. In such cases, trainlined actuating pipes must be connected between units.

Bell Ringer

When the bell ringer is operated, compressed air is directed to the locomotive warning bell operator.

Miscellaneous Switches At Left Of Controller

A dynamic brake circuit breaker, a power reduction switch and rheostat, a cab light switch, or various other miscellaneous switches may be located to the left of the controller.

Headlight Dimming Switch

A five position switch is located on the controller to the right of the throttle. In one position it provides for dim headlights on both ends of the locomotive. In the other positions it provides for a bright or medium headlight at either the front or the rear of the locomotive.

For this switch to function, the two headlight switches on the controller as well as the headlight circuit breaker on the switch and fuse panel must be placed ON.

Load Current Indicating Meter

This meter indicates locomotive pulling force during operation under power and it indicates retarding force during dynamic braking. The meter needle swings to the right to indicate current in a single traction motor circuit during power operation, with 1500 amperes being the maximum reading on the scale. The meter needle swings to the left to indicate dynamic braking current, with 800 amperes being the maximum reading on the scale.

A red area on the meter face indicates when current levels are too high for continuous operation. A short time rating plate under the meter gives the time limitations at various current levels. The times are non-accumulative; that is, considering the conditions under which a locomotive operates, it is not necessary to add intermittent periods requiring high current operation.

During dynamic braking a regulator controls current at 700 amperes, but if the locomotive is equipped for extended range dynamic braking at low track speed, the regulator allows 750 amperes because grid cooling is more effective at lower speeds.

Cab Heater Controls

A heater for the locomotive operator is built into the control stand, and a second heater is located at the observer's station. The operator's heater receives hot water from the No. 1 engine, while the observer's heater receives hot water from the No. 2 engine. Each heater is equipped with the following controls.

1. Blower speed switch for On/Off, Low, Medium, or High speed blower operation.
2. A knob to direct blower air to windshield defrosters or outward to the operating personnel.
3. A valve to turn the hot engine water to the heater on or off.

CAUTION: The ON/OFF valve must be in the ON position when the cooling system is to be drained. It is recommended that the ON/OFF valve be placed in the ON position for several minutes before an engine is to be shut down. Always place or keep the valve in the ON position after the engine is shut down.

Windshield Heater Switch

On special order the windshields may be equipped with a transparent coating on an inner surface of the windshield layers. The coating conducts electricity and gives off sufficient heat to remove frost and prevent it from forming on the outer surface of the windshield.

Indicating Lights

Lights to provide a visual indication of operating conditions or difficulties are installed directly facing the operator. The following lights may be provided, either basically or on special order.

1. Wheel Slip Light

Intermittent flashing of the wheel slip light indicates that the wheel slip control system is doing its job and is correcting the slips. The throttle and locomotive power should not be reduced unless severe lurching threatens to break the train.

Note that minor slips or wheel creep will not activate the wheel slip light, but automatic sanding may take place along with regulation of power to the wheels.

WARNING: A wheel slip light flashing slowly and persistently or burning continuously may indicate a pair of sliding wheels or circuit difficulty. Stop the locomotive and make a careful inspection to ascertain that there are no locked sliding wheels.

2. PCS OPEN Light

The PCS or pneumatic control switch functions to automatically reduce locomotive power in the event that an emergency of safety control air brake application occurs. It does so by reducing the speed of ALL engines to idle.

CAUTION: The engine run switch should be in the OFF position in all trailing units, or (depending on the type and position of locomotives in the consist) it is possible that the PCS switch of the lead unit will not act to reduce engine speeds to idle.

When the switch is tripped the PCS OPEN indicating light on the controller will come on. This light is extinguished and locomotive power restored by resetting the PCS switch. This occurs automatically, provided that:

- a. Control of the air brake is recovered.
- b. The throttle is returned to IDLE position.

3. Sand

This light comes on to indicate that the SANDING No. 1 TRUCK switch is closed and that sand is being applied to the No. 1 axle. The light is not affected by the manual, emergency, or wheel slip sanding circuits.

4. Brake Warning

A brake warning light is installed on units equipped with dynamic brakes. The light indicates excessive braking current when operating in dynamic braking. Due to the use of an automatic brake limiting regulator, the warning light should seldom if ever come on, and then only momentarily. Dynamic braking may be continued with the brake warning light going on and off, but braking effort will be rough. In such cases, the dynamic brake cutout switch on the engine control panel of the affected unit should be placed in the OFF position.

In the event that the brake warning light comes on and does not go out quickly, the braking strength should be immediately reduced to prevent possible equipment damage. Excessive braking strength can be reduced by moving the throttle toward idle position.

Train Control

As a special extra this light is applied as desired.

Signal Light

As a special extra this light is applied as desired.

Handbrake Light

On units so equipped, the handbrake light will come on whenever the handbrake is applied and the trainlined control circuit is energized. The handbrake relay circuit is trainlined, therefore all handbrake lights in a consist will be on if the handbrake is set on any unit equipped with a handbrake light. When the throttle is opened for power with the handbrake set, the alarm bell will ring in all units in the consist.

WARNING: If the lead unit of a mixed consist is not equipped with a handbrake light, power in the consist will be applied normally and no alarm will sound when the throttle is opened for power.

Panel Light Dimmers

Knobs are provided to control the brightness of the control stand gauge lights.

Alarm Silence Button

The alarm bell is located in the control stand for audibility. To silence persistent ringing, such as caused by shutdown of a trailing unit in a consist, the operator need only to press the button. This latches in an alarm silence relay and turns on a light in the alarm silence button as an indication that the fault still exists. Removal of the light bulb will cause the alarm bell to ring again. The alarm or light will continue as long as the fault remains.

Ground Reset Button

When a high voltage ground occurs or five main generator diodes in a group fail, the ground relay operates to drop engine speed and main generator excitation. The alarm bell rings, the H.V.GRD./FAULT light on the engine control panel comes on, and a similar light on the annunciator panel in the electrical cabinet comes on.

To restore engine speed and locomotive power and silence the alarm, it is necessary to wait ten seconds and then press the ground reset pushbutton on the control stand. It is not necessary to isolate the affected unit before pressing the button. Power will be reapplied smoothly when the protective relay is reset, and the H.V.GRD./ FAULT light on the engine control panel will go out. The annunciator indication is latched on and can only be reset by maintenance personnel.

On special order some type of automatic ground reset device may be applied. These devices reset the ground relay automatically and no action is required by the operator. Generally the automatic reset devices will lock out the automatic reset when ground relay trips occur too frequently or too many total times.

Note that a ground relay trip may occur along with a circuit interrupter trip. In such case automatic ground relay reset will occur approximately 1/4 minute before the circuit interrupter reset. Power will not be reapplied until the circuit interrupter has reset.

Attendant Call Pushbutton

The alarm bell rings when this pushbutton is pressed. The button is not latching and does not have to be reset.

MECHANICAL INTERLOCKS ON THE CONTROLLER

The levers on the controller are interlocked so that:

1. With reverse lever in neutral
 - a. Throttle can be moved to any position.
 - b. Selector lever can be moved to any position; OFF, or 1 through 4, except "B."
2. Reverse lever in forward or reverse -
 - a. Throttle can be moved to any position.
 - b. Selector lever can be moved to any position.
3. Throttle lever in IDLE position
 - a. Reverse lever can be moved to any position.
 - b. Selector lever can be moved to any position.
4. Throttle lever in STOP position
 - a. Reverse lever can be moved to any position, but can not be removed from the controller.
 - b. Selector lever can be moved to any position.
5. Throttle above IDLE position
 - a. Reverse lever position can not be changed.
 - b. Selector lever can not be moved out of "B" into OFF or from 1 to OFF. It may however be moved as desired between 1 and 4.

6. Selector lever in OFF position
 - a. Reverse lever can be moved to any position and removed from controller if throttle lever is in IDLE position.
 - b. Throttle can be moved between IDLE and STOP only.
7. Selector lever in "B" position -
 - a. Reverse lever can not be moved.
 - b. Throttle lever can be moved to any position.
8. Selector lever 1, 2, 3, or 4 -
 - a. Reverse lever can be moved to any position.
 - b. Throttle lever can be moved to any position.

Where positions 2, 3 and 4 are incorporated in the selector for manual transition, the handle may be moved to these positions if the reverse lever is in forward or reverse, and with the throttle in any position. Permissible movement of the throttle and reverse levers with the selector in 2, 3 or 4 is the same as with the selector in 1.

AIR BRAKE EQUIPMENT, Fig. 2-8

Basic locomotives are equipped with the type 26L air brakes. Since type 26L is standard equipment, only that type of air brake will be discussed in this manual.

The 26L air brake control equipment is located to the left of the controller. As shown in Fig. 2-8, this equipment consists of an automatic brake, independent brake, multiple unit valve

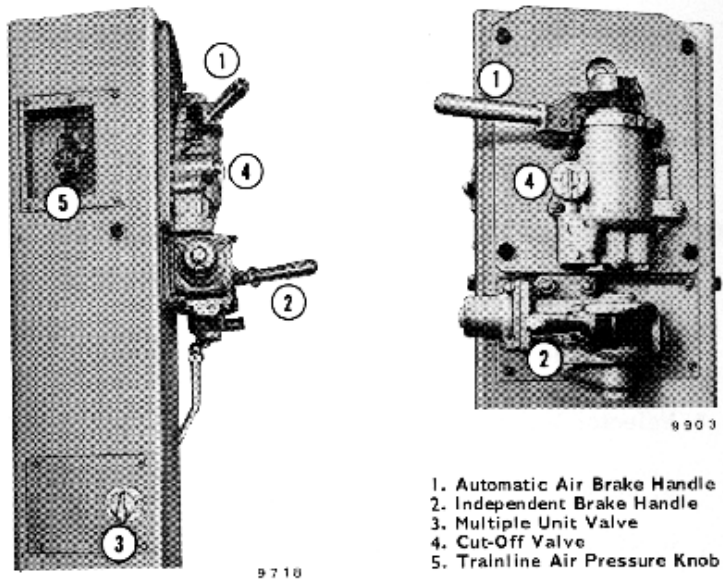

Fig. 2-8 - 26L Air Brake Equipment

(when MU control is installed), cut-off valve and a trainline air pressure adjustment device. The dead engine fixture, a part of the 26L equipment, is shown in Fig. 2-9. The cock is accessible from the locomotive through side doors provided.

Automatic Brake Valve

The auto automatic brake valve handle may be placed in any of six operating positions as shown in Fig. 2-10.

Independent Air Brake, Fig. 2-11

The independent air brake handle is located directly below the automatic brake handle. It has two positions; namely, RELEASE and FULL APPLICATION.

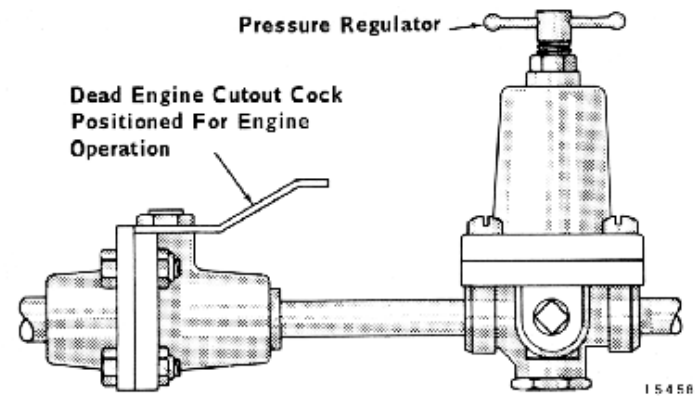

Fig. 2-9 - Dead Engine Cutout Cock

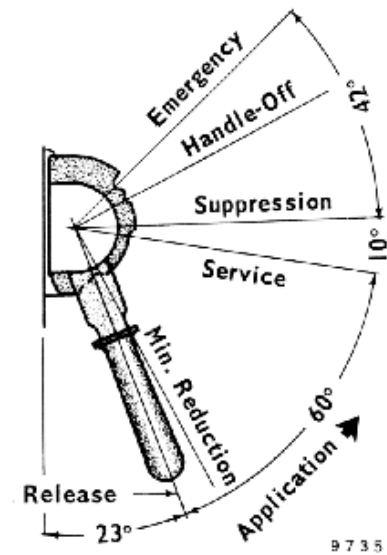

Fig. 2-10 - Automatic Brake Handle Positions

Between these two positions is the application zone. Since this is a self-lapping brake, it automatically laps off the flow of air and maintains brake cylinder pressure corresponding to the position of the handle in the application zone.

Depression of the independent brake valve handle when in the RELEASE position causes release of any automatic brake application existing on the locomotive.

Multiple Unit Valve

The multiple unit (MU-2) valve is located on the left hand side of the air brake stand, as shown in Fig. 2-8. Its purpose is to pilot the F1 selector valve which is a device that enables the air brake equipment of one locomotive unit to be controlled by that of another unit.

The basic MU-2 valve has three positions which are:

1. LEAD or DEAD
2. TRAIL 6 or 26*
3. TRAIL 24

The valve is positioned by pushing in and turning to the desired setting.

* Whenever the MU-2 valve is in the TRAIL 6 or 26 position, and if actuating tramline is not used, then the actuating end connection cutout cock must be opened to atmosphere. This is necessary to prevent the inadvertent loss of air brakes due to possible pressure build-up in the actuating line.

Cut-Off Valve

The cut-off valve is located on the automatic brake valve housing directly beneath the automatic brake valve handle. This valve has the following three positions:

1. CUT-OUT
2. FRT (Freight)
3. PASS (Passenger)

Tramline Pressure Adjustment

The trainline air pressure adjusting knob is located behind the automatic brake valve at the upper portion of the brake pedestal. It is shown in Fig. 2-8.

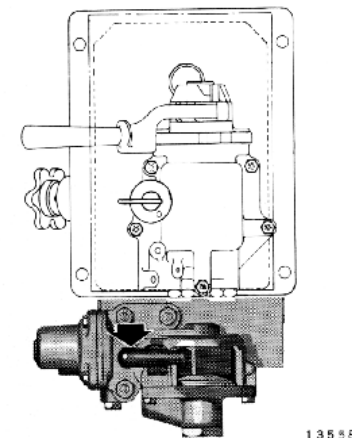
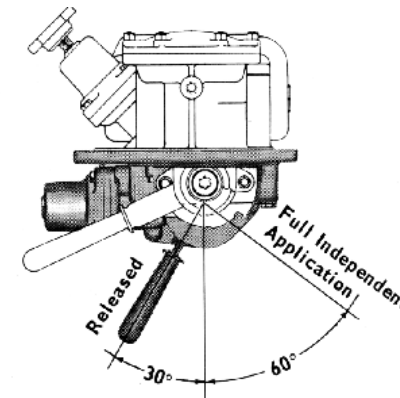

Press Lever Down To Release Automatic Application Of Locomotive Brakes

Fig. 2-11 - Independent Brake Handle Positions

BRAKE EQUIPMENT POSITIONS

When operating locomotives equipped with 26L air brakes, the brake equipment should be positioned according to the information given in Fig. 2-12.

Type Of Service	Automatic Brake Valve	Independent Brake Valve	Cutoff Valve	Dead Engine Cutoff Cock	26D Control Valve	26F Control Valve	MU2 Valve	Overspeed Cutoff Cock	Deadman Cutoff Cock
SINGLE LOCOMOTIVE EQUIPMENT									
Lead	Release	Release	Passenger Freight	Closed		Graduated Direct	Lead	Open	Open
Double Heading	Suppression	Release	Cutoff	Closed		Graduated Direct	Lead	Open	Open
Shipping Dead In Train	Handle Off Position	Release	Cutoff	Open	Relief Valve At Control Reservoir 13 - 24	Direct	Dead	Closed	Closed
MULTIPLE LOCOMOTIVE EQUIPMENT AND EXTRAS									
Lead	Release	Release	Passenger Freight	Closed		Graduated Direct	Lead	Open	Open
Trail	Handle Off Position	Release	Cutoff	Closed		Graduated Direct	*Trail 6 or 26 Trail 24	Open	Open
Shipping Dead In Train	Handle Off Position	Release	Cutoff	Open	Relief Valve At Control Reservoir 13 - 24	Direct Release	Dead	Closed	Closed
Double Heading	Suppression	Release	Cutoff	Closed		Graduated Direct	Lead	Open	Open
Dual Control:									
Operative Station	Release	Release	Passenger Freight	Closed		Graduated Direct	Lead	Open	Open
Non-Operative Station	Handle Off Position	Release	Cutoff						

*Whenever the MU2A valve is in "Trail 6 or 26" position and if the actuating train line is not used, then the actuating end connection cutoff cock must be open to atmosphere, so as to prevent the inadvertent loss of air brakes due to possible pressure buildup in the actuating line.

14910

Fig. 2-12 — Brake Equipment Positions

INTRODUCTION

This section of the manual covers recommended procedures for operation of the locomotive. The procedures are briefly outlined and do not contain detailed explanations of equipment location or function.

The information in this section is arranged in sequence, commencing with inspections in preparation for service, and with instructions for starting the engine, handling a light locomotive, coupling to train, and routine operating phases. The various operating situations and special features such as dynamic braking are also covered.

PREPARATION FOR SERVICE

GROUND INSPECTION

Check locomotive exterior and running gear for:

1. Leakage of fuel oil, lube oil, water or air.
2. Loose or dragging parts.
3. Proper hose connections between units in multiple.
4. Proper positioning of all angle cocks and shut-off valves.
4. Air cut-in to truck brake cylinders.
5. Satisfactory condition of brake shoes.
6. Adequate supply of fuel.
7. Proper installation of control jumper cables between units.

LEAD UNIT CAB INSPECTION

In the cab of the lead unit, the No. 1 engine control locations described in Section 2 of this manual should be checked and the equipment positioned for operation as follows:

Fuse And Switch Panel

1. Main battery switch closed. If it is necessary to close the main battery switch, the turbocharger auxiliary pump light will come on and stay on for 35 minutes.
2. Ground relay switch closed.
3. All fuses installed and in good condition.

Circuit Breaker Panel

1. Control and module control circuit breakers ON.
2. Local control circuit breaker ON.

NOTE: If it is necessary to close the local control breaker, and the circuit interrupter tripped light comes on, it should go out automatically in about 1/2 minute.

3. Fuel pump circuit breaker ON.
4. RV and MB motor control circuit breakers ON.
5. Turbocharger auxiliary pump circuit breaker ON.
6. Lights and headlights circuit breakers ON.
7. Cab heater circuit breaker ON.

*8. Windshield heater, water cooler, and toilet circuit breakers ON, as required.

*9. Overspeed, and automatic water drain circuit breakers ON, as required.

*10. Load test motor control circuit breaker ON.

*Indicates special extra equipment

Engine Control Panel

1. Isolation switch in START position.
2. Headlight control switch in proper position for lead unit operation.
3. Dynamic brake cutout switch in ON (up) position (if provided).
4. Miscellaneous switches positioned as required.

Locomotive Controller

The controller switches and operating levers should be positioned as follows:

1. Place the control and fuel pump switch (switches) in the ON (up) position.
2. Place the engine run switch (if provided) and the generator field switch in the OFF (down) position.
3. Position heater, lights, and miscellaneous switches as desired.
4. Make certain that the throttle remains in idle position and that the reverse lever is removed from the controller.

Air Brakes - Type 26L

1. Insert automatic brake valve handle (if removed) and place in SUPPRESSION position. This will nullify the application of any safety control equipment used.
2. Insert independent brake valve handle (if removed) and move to the FULL APPLICATION position.
3. Position cutoff valve to either FRGT or PASS cut-in depending upon make-up of the train.
4. Place MU valve in LEAD position.

INSPECTION AT THE NO. 2 ELECTRICAL CABINET

At the walkway on the left side of the locomotive at the far hood end, the No. 2 circuit breaker panel and the No. 2 engine control panel are located at eye level behind a latched door. Set up the applicable switches and circuit breakers in the same manner as for the No. 1 end.

CAUTION: It is not necessary to enter the electrical cabinet compartment at the No. 2 end of the locomotive in order to set up the controls for operation. Make certain that the No. 2 electrical cabinet compartment doors are securely latched before placing the locomotive in service.

ENGINE ROOM INSPECTION

The No. 1 and No. 2 engines can readily be inspected by opening the access doors along the sides of the long hood end of the locomotive.

1. Check air compressor for proper lubricating oil supply.

2. Observe for proper water level on tank sight glass.
3. Check all valves for proper positioning.
4. Check for leakage of fuel, lubricating oil, water, or air.

ENGINE INSPECTION

The engine should be inspected before as well as after starting. After inspection and engine start, all engineroom doors should be closed and latched securely, as the engineroom is pressurized during operation.

1. Check that engine overspeed lever is set, Fig. 3-1.

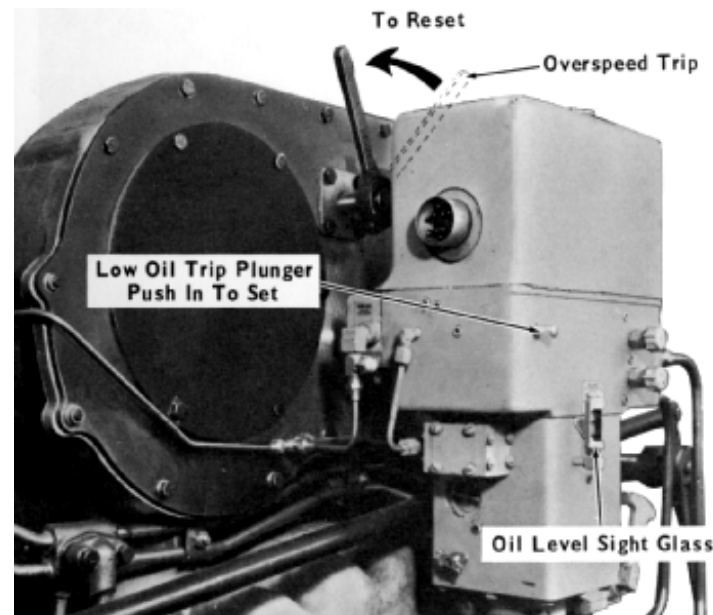
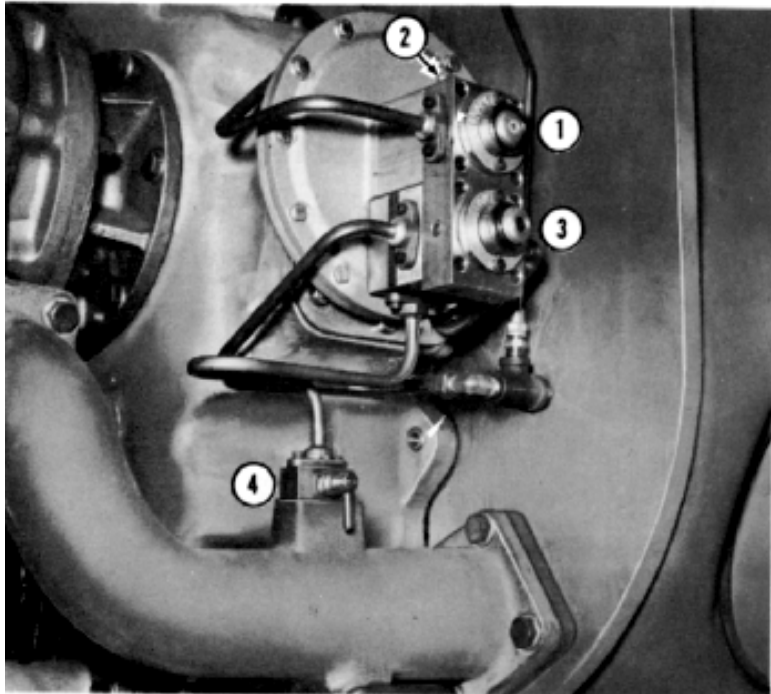

Fig. 3-1 - Engine Overspeed Trip And Low Oil Pressure Trip Plunger

2. Observe that the governor low oil pressure trip plunger is set, Fig. 3-1, and that there is oil visible in the governor sight glass.
3. Observe that the crankcase (oil pan) pressure and low water detector reset buttons are set (pressed in). If the buttons protrude, Fig. 3-2, press and hold in for 5 seconds to latch the buttons in.



1. Crankcase Pressure Reset
2. Vent And Test Opening (Crankcase)
3. Low Water Reset
4. Test Cock (Low Water)

Fig. 3-2 - Low Water And Crankcase (Oil Pan) Pressure Detector

4. Observe that engine top deck, air box, and oil pan inspection covers are in place and securely closed.

STARTING THE DIESEL ENGINES

After the preceding inspections have been completed, the diesel engines may be started. Starting controls are located at the accessory end of the engines in the area of the equipment racks. Perform the following at the No. 1 engine.

1. If engine temperature is below 40 degrees F., preheat the engine.
2. Place the fuel prime/engine start switch in the FUEL PRIME position and hold it there for 10 to 15 seconds to prime the fuel system,
3. When the return fuel sight glass, Fig. 3-3, is full and free of bubbles, position the injector rack positioning lever (layshaft) at about one-third rack (about 1.6 on the scale) before cranking is started. Then move the fuel prime/engine start switch to the ENGINE START position. Hold the layshaft firmly at the 1.6 rack until the engine starts.

CAUTION- Do not crank the engine for more than 20 seconds at a starting attempt, and always allow a full 2 minute cool-down period between cranking attempts,

Do not crank the engine for short repeated intervals to turn the engine over. Such cranking can overheat and destroy starting components,

If the cylinders are overfueled during cranking, pull layshaft full out and crank to purge, then position at 1.6.

4. Immediately after the engine starts, check low water buttons on the detector, Fig. 3-2, and hold in for 5 seconds if needed. Check that engine oil pressure, engine oil level, and governor oil level are satisfactory.
5. Check that the engine cooling water level does not fall below the "LOW" mark on the "Engine Running" portion of the water level gauge plate. If the water level is slightly low, the engine may continue to run at idle speed, but may shut down when the throttle is advanced.

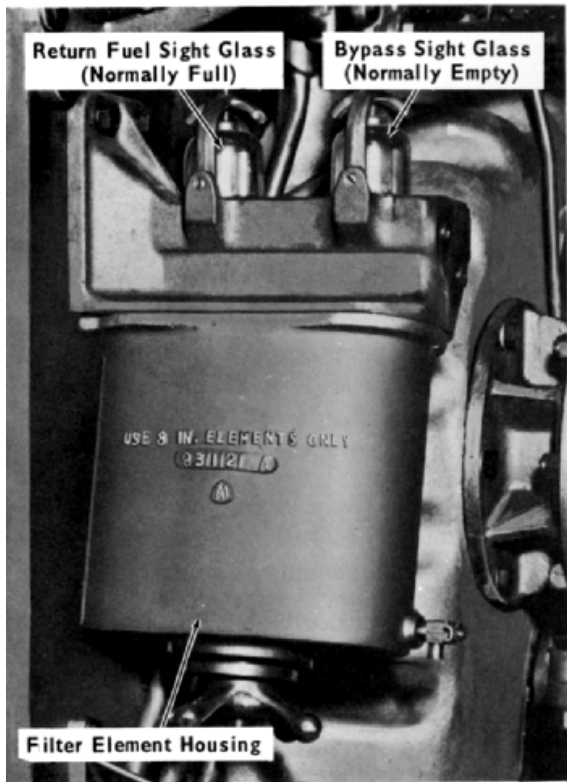

Fig. 3-3 - Fuel Oil Sight Glasses

WARNING: Do not overfill the engine cooling system. Always operate the relief valve to release cooling system pressure or excess coolant before opening water tank plugs.

Starting the No. 2 engine.

Starting procedures for the No. 2 engine are the same as for the No. 1 engine.

NOTE: After starting the second engine of a unit, always verify that the fuel pump motor of the other engine, continues to run. If the pump has stopped running, shut the engine down and check fuses.

TRAILING UNIT CAB INSPECTION

Switches, circuit breakers, and control equipment located in the cab of a trailing unit should be checked for proper positioning as follows:

Fuse And Switch Panel

1. Main battery switch and ground relay cutout switch closed.
2. All fuses installed and in good condition.

Circuit Breaker Panel

1. Control and module control circuit breakers ON.
2. Local control circuit breaker ON.
3. Fuel pump circuit breaker ON.

4. RV and MB motor control circuit breakers ON.
5. Turbocharger auxiliary pump circuit breaker ON.
6. Lights circuit breaker ON. Headlights circuit breaker ON or OFF.
- *7. Cab heater, windshield heater, water cooler, and toilet circuit breakers ON as desired and as applicable.
- *8. Automatic water drain circuit breaker ON.
- *9. Load test motor control circuit breaker ON.

*Indicates special extra equipment.

Engine Control Panel

1. Isolation switch in START position, and headlight control switch in position to correspond with unit position in consist.
2. Dynamic brake cutout switch in ON (up) position (if provided).
3. Other switches may be placed ON or OFF as needed, as they do not affect locomotive operation.

TRAILING UNIT NO. 2 END INSPECTION

The switches and circuit breakers on the No. 2 end of a trailing unit are to be positioned the same way as the No. 2 end of the lead unit.

STARTING TRAILING UNIT DIESEL ENGINES

Engines in trailing units are started in the same manner as the engine in the lead unit.

PLACING UNITS ON THE LINE

After the diesel engines are started and inspected, units may be placed on the line as desired by placing the isolation switch on the engine control panel in the RUN position. If the consist is at a standstill, be certain that the throttle levers in all units are in the idle position before placing any unit on the line.

Locomotive Controller

The controller switches and operating levers of trailing units should be positioned as follows:

1. Control and fuel pump switch (switches), generator field switch, and engine run switch must in the OFF position.
2. Throttle idle.
3. Selector lever indexed to OFF position.
4. Reverse lever placed in neutral and then removed from the controller to lock other levers.

Air Brakes - Type 26L

1. Place automatic brake valve handle in HANDLE OFF position. Remove handle (if so equipped).
2. Place independent brake valve handle in FULL RELEASE position. Remove handle (if so equipped).
3. Place MU valve in desired position for trailing unit operation.
4. Place cutoff valve in CUT OUT position.

PRECAUTIONS BEFORE MOVING LOCOMOTIVES

The following points should be carefully checked before attempting to move the locomotive under its own power:

1. MAKE SURE THAT MAIN RESERVOIR AIR PRESSURE IS NORMAL (approximately 130-140 pounds).

This is very important, since the locomotive is equipped with electro-magnetic switchgear which will function in response to control and permit operation without air pressure for brakes.

2. Check for proper application and release of air brakes.
3. Release hand brake and remove any blocking under the wheels.

HANDLING LIGHT LOCOMOTIVE

With the engine started and placed "on-the-line" and the preceding inspections and precautions completed, the locomotive is handled as follows:

1. Place the engine run switch and generator field switch in ON (up) position.
2. Place headlight and other lights ON as needed.
3. Insert reverse lever and move it to desired direction of travel, either forward or reverse.
4. Place selector lever in No. 1 position (if so equipped).
5. Depress safety control foot pedal (if so equipped).

6. Release air brakes.
7. Open throttle to Run 1, 2, or 3 as needed to move locomotive at desired speed.

NOTE: Locomotive response to throttle movement is almost immediate. There is no delay in power buildup.

Engine should not be operated above throttle position No. 3 until water temperature is greater than 130° F.

8. Throttle should be in IDLE before coming to a dead stop.
9. Reverse lever should be moved to change direction of travel only when locomotive is completely stopped.

DRAINING OF AIR RESERVOIRS AND STRAINERS

The air reservoirs and air strainers or filters should be drained at least once each day whether or not equipment is provided with automatic drain valves. Draining should be done at the time of crew change until a definite schedule is established by the railroad.

1. Momentarily operate the manual override lever on auxiliary main reservoir centrifugal filter, 2, Fig. 3-4 and Fig. 3-5.
2. Momentarily operate the manual override lever on the main reservoir centrifugal filter, 1, Fig. 3-4 and Fig. 3-5.

NOTE: Solenoid override plunger is inoperative when drain valve solenoid is energized.

3. Press up on the pushbutton at the base of the compressor control strainer drain, Fig. 3-6.

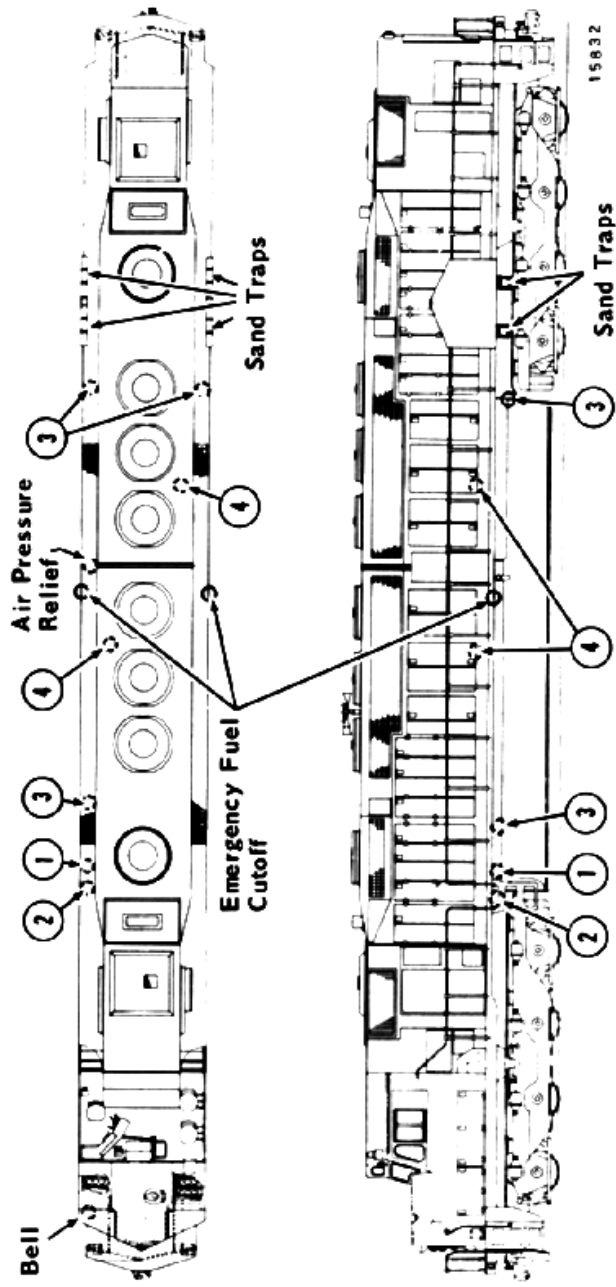

- 1. Main Reservoir Centrifugal Filter And Drain
- 2. Auxiliary Main Reservoir Centrifugal Filter And Drain
- 3. Main Reservoir Drain Valve Location
- 4. Compressor Control Strainer Drain Valve Location

Fig. 3-4 - Compressed Air System Drain Valve Locations

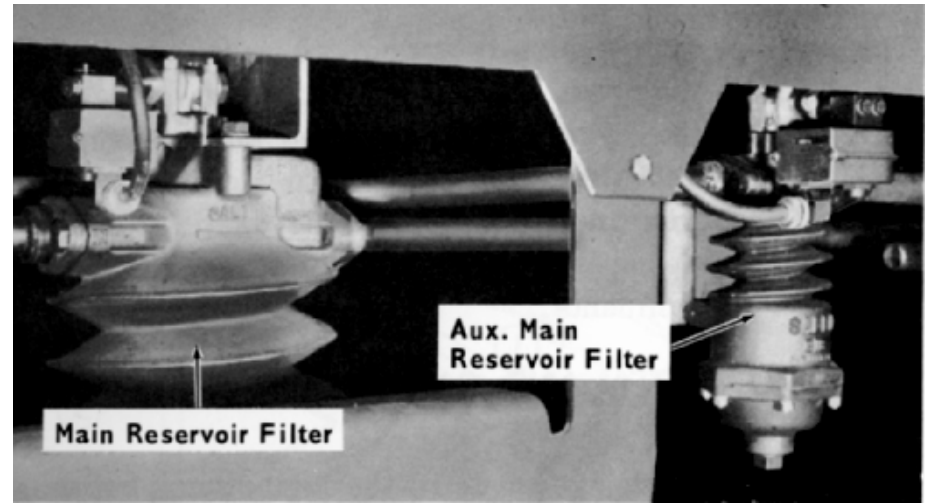

Fig. 3-5 - Main And Auxiliary Main Reservoir Centrifugal Filters And Filter Drains

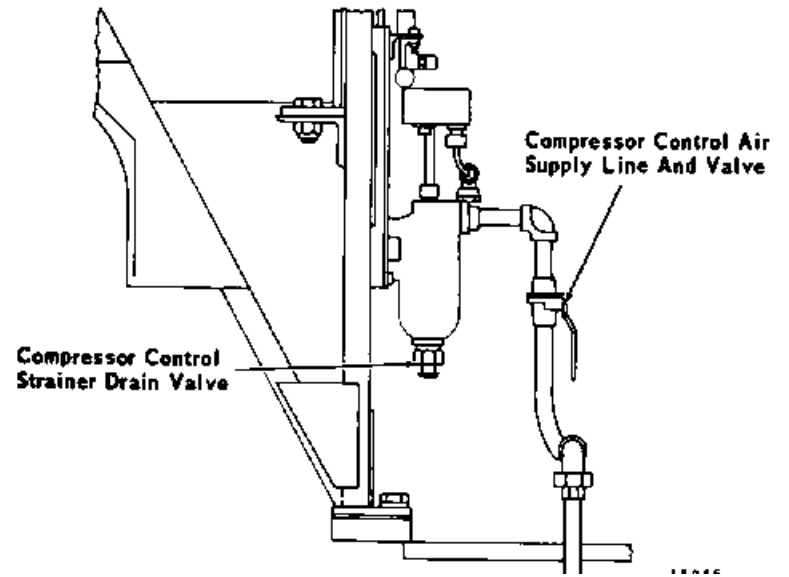

Fig. 3-6 - Compressor Control Strainer Drain Valve

ENGINE AIR BOX DRAIN

The system is completely automatic and requires no attention by the locomotive operator. A metal casting mounted on the front end plate of the engine connects pipes from each side of the airbox to a common drain pipe. Pressures in opposition at the casting restrict air flow to a permissible amount, yet allow elimination of airbox contaminants.

COOLING SYSTEM AND CAB HEATER DRAIN VALVES

Water drain valves are located at the engine sump between the engine and the accessory rack. Cab heater supply and return line valves are located in the same area, Fig. 3-7. When it is necessary for the locomotive operator to shut down an engine and drain the cooling system, all valves must be opened (handles parallel to pipe). Also, the valve on the cab heater must be in the ON position to allow the cab heater piping to drain.

Note that the operator's cab heater is supplied by the No. 1 engine, while the observers cab heater is supplied by the No. 2 engine. The arrangement provides a greater amount of heat available, and it allows shutdown of one engine on a DDA40X locomotive without total loss of cab heat.

During operation of the locomotive, the drain valves must be one of the following conditions. Valves are open with handles parallel to pipe and closed with handles at right angles to pipe. The cab heater valve is labeled ON/OFF.

1. Normal Operation

Main engine water drain valve and cab heater drain valves closed. Heater supply and return line valves opened. Cab heater valve in ON position.

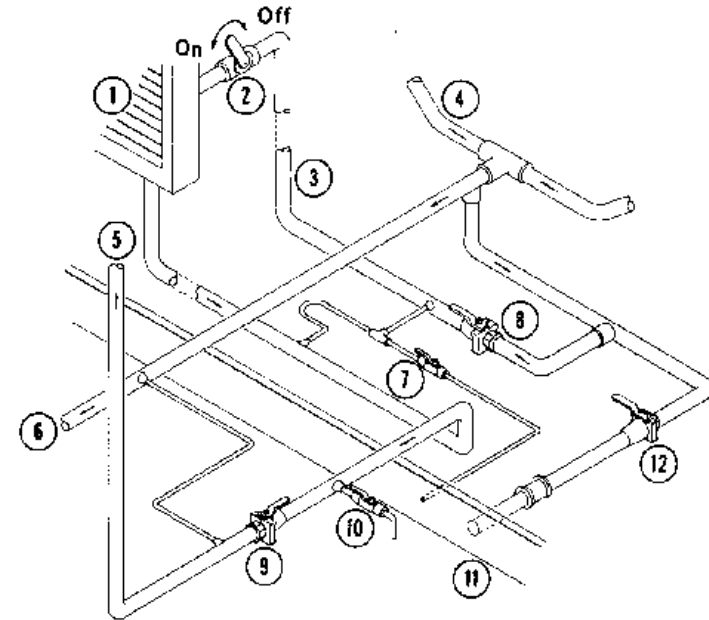

- | | |
|----------------------------|--------------------------------|
| 1. Cab Heater | 7. Cab Heater Drain |
| 2. Cab Heater Valve | 8. Cab Heater Supply Shutoff |
| 3. Heater Supply Line | 9. Cab Heater Return Shutoff |
| 4. From Engine Water Pumps | 10. Cab Heater Drain |
| 5. Return From Heater | 11. Sump Pan |
| 6. To Air Compressor | 12. Cooling System Drain Valve |

Fig. 3-7 - Engine And Cab Heater Drain Valve Locations - Manual Valves

CAUTION: During freezing weather the cab heater supply and return line valves must be open and the cab heater ON/OFF valve must be in the ON position to prevent freezing of the cab heater and piping.

2. Heater shutdown due to a leak.

Heater supply and return line valves closed. Both heater drain valves open. Cab heater ON/OFF valve in the ON position to allow complete drainage from cab heater and piping.

3. Engine shutdown; Freezing conditions possible.

All supply and return drain valves open. Fuel pre-heater drain valve open. Cab heater ON/OFF valve in the ON position. This valve must be in the ON position to allow complete drainage of cab heater and piping.

On units equipped with special automatic cooling system drains, the automatic water drain circuit breaker must be in the ON position.

COUPLING LOCOMOTIVE UNITS TOGETHER

When coupling units together for multiple unit operation, the procedure below should be followed:

1. Couple and stretch units to ensure couplers are locked.
2. Install control cable between unit; also dynamic breaking cables, if so equipped, and if operation with field loop control of dynamic brakes is desired. Make steam connections if applicable.

NOTE: If the consist is made up with older units that are equipped for only pneumatic control of sanding, connect actuating pipes between all units in the consist.

3. Attach platform safety chains between units.
4. Perform ground, engineroom and engine inspections as outlined in preceding articles.
5. Position cab controls for trailing unit operation as outlined in preceding articles.

6. Connect air brake hoses between units as required.
7. Open required air hose cutout cocks on both units.

COUPLING LOCOMOTIVE TO TRAIN

Locomotive should be coupled to train using the same care taken when coupling units together. After coupling make the following checks:

1. Test to see that couplers are locked by stretching connection.
2. Connect air brake hoses, and make steam connections if applicable.
3. Slowly open air valves on locomotive and train to cut in brakes.
4. Pump up air if necessary, using the following procedure.

PUMPING UP AIR

After cutting in air brakes on train, note the reaction of the main reservoir air gauge. If pressure falls below trainline pressure, pump up air as follows:

1. Place generator field switch in OFF (down) position.
2. Move reverse lever to neutral position.
3. Open throttle as needed to speed up engine and thus increase air compressor output.

NOTE: Throttle may be advanced to RUN 4 or 5 if necessary. Engine should not however be run unloaded (as in pumping up air) at speeds beyond throttle No. 5 position.

BRAKE PIPE LEAKAGE TEST

Prior to operating the 26L brake equipment, a leakage test must be performed. This is accomplished in the following manner.

1. The cutoff valve is positioned in either FRGT or PASS, depending on the equipment make up of the train.
2. Move the automatic brake valve handle gradually into service position until the equalizing reservoir gauge indicates that a 15 psi reduction has been made.
3. Without any further movement of the automatic brake valve handle, observe the brake pipe gauge until this pressure has dropped 15 psi and exhaust has stopped blowing.
4. At this moment turn the cutoff valve to CUT OFF position. This cuts out the maintaining function of the brake valve.
5. From the instant the cutoff valve is turned to CUT OFF position, the brake pipe gauge should be observed and any possible drop in brake pipe pressure should be timed for one minute. Brake pipe leakage must not exceed the rate established by railroad rules.
6. After checking trainline leakage for one minute and the results are observed to be within required limits, return the cutoff indicator to the required position (FRGT or PASS) and proceed to reduce the equalizing gauge pressure until the pressure is the same as brake pipe gauge pressure. This is accomplished by moving the automatic brake valve handle gradually to the right until a full service application has been obtained.

7. After pipe leakage test has been completed, return the automatic brake valve handle to RELEASE position.

STARTING A TRAIN

The method to be used in starting a train depends upon many factors such as, the type of locomotive being used; the type, weight and length of the train and amount of slack in the train; as well as the weather, grade and track conditions. Since all of these factors are variable, specific train starting instructions cannot be provided and it will therefore be up to the operator to use good judgment in properly applying the power to suit requirements. There are, however, certain general considerations that should be observed. They are discussed in the following paragraphs.

A basic characteristic of the diesel locomotive is its HIGH STARTING TRACTIVE EFFORT, which is DIRECTLY RELATED TO THROTTLE POSITION. The design of the locomotive power control system is such that tractive effort is low in low throttle position and high in high throttle position, and this effort is available immediately as the throttle is positioned. These characteristics make the use of independent locomotive brakes or the manipulation of the throttle between run 1 and idle generally unnecessary during starting.

The available tractive effort does however make it imperative that the air brakes be completely released before any attempt is made to start a train. On an average 100 car freight train having uniformly distributed leakage, it may take 10 minutes or more to completely release the brakes after a reduction has been made. It is therefore important that sufficient time be allowed after stopping, or otherwise applying brakes, to allow them to be fully released before attempting to start the train.

The locomotive possesses sufficiently high tractive effort to enable it to start most trains without taking slack. The practice of taking slack indiscriminately should thus be avoided. There will, however, be instances in which it is advisable (and sometimes necessary) to take slack in starting a train. Care should be taken in such cases to prevent excessive locomotive acceleration which will cause undue shock to draft gear and couplers, and lading.

Proper throttle handling is important when starting trains, since it has a direct bearing on the power being developed. As the throttle is advanced, a power increase occurs almost immediately, and power applied is at a value dependent upon throttle position. It is therefore advisable to advance the throttle one notch at a time when starting a train. A train should be started in as low a throttle position as possible, thus keeping the speed of the locomotive at a minimum until all slack has been removed and the train completely stretched. Sometimes it is advisable to reduce the throttle a notch or two at the moment the locomotive begins to move in order to prevent stretching slack too quickly or to avoid slipping.

Note, however, that the IDAC wheel slip control system functions to correct slips by instantaneous reduction of power in small increments and by application of sand. The cumulative effect of a large number of power reductions by the wheel slip system is to cause the locomotive to maintain power at a level where adhesion can be maintained.

When ready to start, the following general procedure is recommended:

1. Place the selector lever (if used) in the No. 1 position.
2. Move reverse lever to the desired direction, either forward or reverse.
3. Place engine run (if applied) and generator field switches in the ON (up) position.
4. Release both automatic and independent air brakes.
5. Open the throttle one notch every few seconds as follows:
 - a. To run 1 - The engine will quickly load, but the loading will stop at a specific low value. This may be noted on the load indicating meter. At an easy starting place the locomotive may start the train.

NOTE: The design of the locomotive power control system makes it generally unnecessary to apply locomotive independent brakes or to manipulate the throttle between run 1 and idle during starting. b. To run 2, 3 or higher (experience and the demands of the schedule will determine this) until the locomotive moves.

6. Reduce throttle one or more notches if acceleration is too rapid.
7. After the train is stretched, advance throttle as desired.

NOTE: When operating at full throttle to climb a hill or to accelerate, the IDAC wheel slip control system reacts so rapidly to correct minor slips by means of power reduction and sanding that the wheel slip light seldom comes on to indicate severe slips. This wheel slip corrective action is often seen at the load current indicating meter as a steady reduction of load current below that which is normally expected at full throttle for a given speed. Do not misinterpret this power reduction as a fault. It is merely the wheel slip control system doing its job and maintaining power at a level within the adhesion conditions established by track and grade.

ACCELERATING A TRAIN

After the train has been started, the throttle can be advanced as rapidly as desired to accelerate the train. The speed with which the throttle is advanced depends upon demands of the schedule and the type of locomotive and train involved. In general however, advancing the throttle one notch at a time is desired to prevent slipping. The load indicating meter provides the best guide for throttle handling when accelerating a train. By observing this meter it will be noted that the pointer moves toward the right (increased amperage) as the throttle is advanced. As soon as the increased power is absorbed, the meter pointer begins moving toward the left. At that time, the throttle may again be advanced. Thus for maximum acceleration without slipping, the throttle should be advanced one notch each time the meter pointer begins moving toward the left until full power is reached in throttle position 8.

DRAG DUTY POWER CONTROL

The DDA40X locomotive is equipped with a system for "maximum performance control" that operates in conjunction with the IDAC wheel slip control system to ensure either optimum or maximum short time power as well as optimum continuous power to the traction motors under various operating conditions. The systems accomplish the following.

1. Application of as much available horsepower to the traction motors as adhesion conditions will allow.
2. Application of full available horsepower to the traction motors at any track speed until high load load current levels cause the traction motors to become hot. Power is then automatically reduced to protect the motors and to obtain characteristics indicated in Steps 3 and 4 below.
3. At a standard or special speed that matches other models of locomotives, the system regulates power to allow as much load current to the traction motors as they can continuously accept without damage. At slower speeds and high throttle position load current will be greater than allowed continuously and short time ratings must be observed.
4. At load currents greater than allowed continuously, power is regulated to match the DDA40X short time characteristics with those of other locomotive models.

OPERATING OVER RAIL CROSSING

When operating the locomotive at speeds exceeding 25 MPH, reduce the throttle to a RUN 4 position at least eight seconds

before the locomotive reaches a rail crossing. If the locomotive is operating in Run 4 position or lower, or running less than 25 MPH, allow the same interval and place the throttle in the next lower position. Advance the throttle after all units of the consist have passed over the crossing. This procedure is necessary to ensure decay of motor and generator voltage to a safe level before the mechanical shock that occurs at rail crossings is transmitted to the motor brushes.

RUNNING THROUGH WATER

Under ABSOLUTELY NO CIRCUMSTANCES should the locomotive be operated through water deep enough to touch the bottom of the traction motors. Water any deeper than 3" above the rail is likely to cause traction motor damage.

When passing through any water on the rails, exercise every precaution under such circumstances and always go very slowly, never exceeding 2 to 3 MPH.

WHEEL SLIP CORRECTION

Instantaneous reduction of locomotive power together with automatic sanding functions to correct wheel slip. After adhesion is regained, a timed application of sand continues while power is smoothly restored. The system functions entirely automatically, and no action is required by the locomotive operator.

Depending upon the seriousness of slipping, the wheel slip light may or may not flash on and off as the wheel slip control system functions to correct the slips. However, the IDAC wheel slip control system reacts so rapidly to correct minor slips that the

wheel slip light seldom comes on to indicate severe slips. The wheel corrective action is often seen at the load current indicating meter as a steady reduction of load current below that which is normally expected at full throttle for a given speed. Do not misinterpret this power reduction as a fault. It is simply the wheel slip control system doing its job and maintaining power at a level within the adhesion conditions established by track and grade.

NOTE: Whenever possible, operation on grades should be at full throttle position. Throttle reduction during wheel slip is recommended only when wheel slip conditions are such that repeated wheel slip causes severe lurching that may pull a train apart. Such severe conditions may indicate the need for a helper or the need to take the train up the hill in two parts.

WHEEL SLIP LIGHT

If the wheel slip light blinks on and off slowly and persistently or burns continuously during locomotive operation, a pair of wheels may be sliding or circuit difficulty may exist. Due to the seriousness of sliding wheels, under such indications the locomotive should be IMMEDIATELY STOPPED and an investigation made to determine the cause. The wheels may be sliding due to a locked brake, damaged traction motor bearings, or broken pinion or gear teeth.

Repeated ground relay or circuit interrupter tripping accompanied by unusual noises such as thumping or squealing, may also indicate serious traction motor trouble that should be investigated at once.

Do not allow any unit that must be isolated due to repeated circuit interupter action or repeated wheel slip or ground relay action to remain in a locomotive consist UNLESS IT HAS BEEN ABSOLUTELY DETERMINED THAT ALL OF ITS WHEELS ROTATE FREELY.

LOCOMOTIVE SPEED LIMIT

The maximum speed at which the locomotive can be safely operated is determined by the gear ration. This ratio is expressed as a double number such as 59:18. The 59 indicates the number of teeth on the axle gear while the 18 represents the number of teeth on the traction motor pinion gear.

Since the two gears are meshed together, it can be seen that for this particular ratio the motor armature turns approximately three times for a single revolution of the driving wheels. The locomotive speed limit is therefore determined by the maximum permissible rotation speed of the motor armature. Exceeding this maximum could result in serious damage to the traction motors.

Various gear ratios are available to suit specific locomotive operating requirements. For each gear ratio, there is a maximum operating speed. This information is given in the "General Data" section at the beginning of this manual.

If the locomotive is operated at a speed higher than that stipulated as maximum for the particular gear ratio, the locomotive control system will first cutback on available power due to a voltage limitation. If speed still increases or if a simultaneous slip occurs, complete interruption of power will occur and rough regulation will hold locomotive speed back.

MIXED GEAR RATIO OPERATION

If the units of the consist are of different gear ratios, the locomotive should not be operated at speeds in excess of that recommended for the unit having the lowest maximum permissible speed. Similarly, operation should never be slower than the minimum continuous speed (or maximum motor amperage) for units having established short time ratings.

To obtain a maximum tonnage rating for any single application, Electro-Motive will, upon request, analyze the actual operation and make specific tonnage rating recommendations.

DYNAMIC BRAKING

Dynamic braking, on locomotives so equipped, can prove extremely valuable in retarding train speed in many phases of locomotive operation. It is particularly valuable while descending grades, thus reducing the necessity for using air brakes.

Depending on locomotive gear ratio, the maximum braking strength is obtained between 18 and 25 MPH. At train speeds higher than the optimum, braking effectiveness gradually declines as speed increases. For this reason, it is important that dynamic braking is started BEFORE train speed becomes excessive. While in dynamic braking, the speed of the train should not be allowed to "creep" up by careless handling of the brake.

If the locomotive is equipped with the basic dynamic brake, braking strength rapidly declines as speed falls below the optimum (nominally 24 MPH). However, on special order the extended range dynamic brake may be provided. The extended

range system maintains near maximum braking strength down to train speed of about 6 MPH. At lower train speeds dynamic braking strength declines rapidly.

To operate dynamic brakes, proceed as follows:

1. The reverse lever must be positioned in the direction of the locomotive movement.
2. Throttle must be reduced to idle.
3. Move selector from No. 1 to OFF position. Pause 10 seconds before proceeding.
4. Move the selector lever to the "B" or braking position. This establishes the dynamic braking circuits. It will also be noted that a slight amount of braking effort occurs, as evidenced by the load current indicating meter.
5. After the slack is bunched, the throttle is used to control dynamic braking strength. As it is advanced about 13° away from IDLE it will be noted that the engine speed automatically increases.
6. Braking effort may be increased by slowly advancing the throttle to the full 8th position if desired. Maximum braking effort is automatically limited to 700 amperes by a dynamic brake current limiting regulator, module DR.

If the locomotive is equipped for extended range dynamic brakes, braking current is regulated at 750 amperes maximum as train speed slows to about 22 MPH.

7. With automatic regulation of maximum braking strength, the brake warning light on the controller should seldom give indication of excessive braking current. If the brake warning light does flash on however, movement of the throttle handle should be stopped until the light goes out.
8. If the light fails to go out after several seconds, move the throttle handle back towards IDLE slowly until the light does go out. After the light goes out, throttle may again be advanced to increase braking effort.

NOTE: The brake warning light circuit is "trainlined" so that, a warning will be given in the lead unit if any unit in the consist is generating excessive current in dynamic braking. Thus regardless of the load indicating meter reading (which may be less than brake rating), whenever the warning light comes on, it should not be allowed to remain on for any longer than two or three seconds before steps are taken to reduce braking strength.

9. When necessary, the automatic brake may be used in conjunction with the dynamic brake. However' the independent brake must be KEPT FULLYRELEASED whenever the dynamic brake is in use, or the wheels may slide. As the speed decreases below 10 MPH the basic dynamic brake becomes less effective. When the speed further decreases, it is permissible to completely release the dynamic brake by placing the selector lever in the OFF or No. 1 position, applying the independent brake simultaneously to prevent the slack from running out.

The locomotive can be operated in dynamic braking when coupled to older units that are not equipped with brake current

limiting regulators. If all the units are of the same gear ratio, the unit having the lowest maximum brake current rating should be placed as the lead unit in the consist. The operator can then operate and control the braking effort up to the limit of the unit having the lowest brake current rating, without overloading the dynamic brake system of a trailing unit. The locomotive consist **MUST** always be operated so as not to exceed the braking current of the unit having the lowest maximum brake current rating.

Units equipped with dynamic brake current limiting regulators can be operated in multiple with DDA40X locomotives in dynamic braking regardless of the gear ratio or difference in the maximum brake current ratings.

Units not equipped with dynamic brake current limiting regulators and of different gear ratios will require special operating instructions when used in multiple with a DDA40X locomotive in dynamic braking.

DYNAMIC BRAKE WHEEL SLIDE CONTROL

During dynamic braking, each series group of two traction motors is connected in parallel with each dynamic braking resistor grid circuit and with the other series group of two traction motors. With this arrangement, when a wheel slips it may be motored by other motors in the system. This in effect make a wheel slip during dynamic braking somewhat self correcting. However, the parallel arrangement of dynamic braking resistor grids and traction motors is such that the full response of the IDAC wheel slip control system is available during dynamic braking as well as during power operation. The precise and immediate regulation maintained by IDAC, plus the

motoring effect created by the parallel arrangement, provides extremely stable dynamic brake operation.

In addition to the above, a bridge circuit is employed to protect against the possibility of simultaneous slips that may not be detected by IDAC.

When a pair of wheels is detected tending to rotate at a slower speed, the retarding effort of the traction motors in the unit affected is reduced (traction alternator field excitation is reduced in the unit affected) and sand is automatically applied to the rails. When the retarding effort of the traction motors in the unit is reduced, the tendency of the wheel set to rotate at a slower speed is overcome. After the wheel set resumes normal rotation, the retarding effort of the traction motors returns (increases) to its former value. Automatic sanding continues for 3 to 5 seconds after the wheel slide tendency is corrected.

DOUBLE HEADING

Prior to double heading behind another locomotive, make a full service brake pipe reduction with the automatic brake valve, and place the cutoff valve in CUTOFF position. Return the automatic brake valve handle to the release position and place the independent brake valve in release position. On 26L equipment place the MU valve in LEAD position.

The operation of the throttle is normal, but the brakes are controlled from the lead locomotive. An emergency air brake application may be made, however, from the automatic brake valve of the second unit. Also, the brakes on this unit may be released by depressing the independent brake valve handle while it is in the released position.

OPERATION IN HELPER SERVICE

Basically, there is no difference in the instructions for operating the locomotive as a helper or with a helper. In most instances it is desirable to get over a grade in the shortest possible time. Thus, wherever possible, operation on the grades should be in the full throttle position. The throttle can be reduced, however, where wheel slips cause lurching that may threaten to break the train.

ISOLATING A UNIT

When the occasion arises where it becomes advisable to isolate a locomotive unit, observe the following:

1. When operating under power, a unit may be isolated at any time, but discretion as to timing and necessity should be used.
2. When operating in dynamic braking, it is important to get out of dynamic braking before attempting to isolate the unit. This is done by reducing the braking lever (throttle) to IDLE. The isolation switch can then be moved to START position to eliminate the braking on that unit. If the braking is resumed, other units will function normally. If field loop control of dynamic brakes is being used, do not change position of the unit selector switch.

CHANGING OPERATING ENDS

When the locomotive consist includes two or more units with operating controls, the following procedure is recommended in changing from one operating end to the opposite end on locomotives equipped with 26L brakes.

ON END BEING CUT OUT

1. Move the automatic brake valve handle to service position and make a 20 pound reduction.
2. After brake pipe exhaust stops, place cutoff valve in CUT OUT position by pushing dial indicator handle in and turning to the desired position.
3. Place independent brake in fully released position.
4. Place MU valve in the desired TRAIL position, depending on brake equipment on trailing units. (MU valve is located in the left hand side of the air pedestal. Push dial indicator inward and turn to desired position.)
5. Position automatic brake valve in handle off position. (Handle may be removed if so equipped.)
6. Place selector lever in OFF position.
7. Place reverse lever in neutral position and remove to lock controller.
8. At the controller, place all switches in the OFF position. Be absolutely certain that the control and fuel pump switch, generator field switch, and engine run switch are in the OFF position.
9. At the engine control panel, place headlight control switch in proper position for trailing unit operation. Place other switches ON as needed.
10. At the circuit breaker panel, the control circuit breaker and the local control circuit breaker remain in the ON position.

NOTE: If the local control circuit breaker is inadvertently placed OFF at this time, the engine will shut down when the

trainlined control circuit is re-established. However, the engine may be restarted in the normal manner after placing the local control circuit breaker ON.

11. After completing the operations outlined in the preceding steps, move to the cab of the new lead unit. No changes need be made at the No. 2 end of the lead unit.

ON END BEING CUT IN

1. At the controller, make certain throttle lever is in IDLE, selector lever is in OFF, and the generator field switch is OFF.
2. Insert reverse lever and leave in neutral position.
3. Insert automatic brake valve handle (if removed) and place in SUPPRESSION position to nullify any safety control, overspeed, or train control used.
4. Insert independent brake valve handle (if removed) and move handle to full independent application position.
5. Position cutoff valve in either FRGT or PASS position depending on make up of the train.
6. Place MU valve in LEAD position.
7. At the circuit breaker panel, check that the control circuit breaker is in the ON position. Other circuit breakers remain ON.
8. At the engine control panel, place the headlight control switch in proper position, and other switches on as needed. If the unit selector switch is used it must be properly positioned.

9. At the controller, place the engine run, control and fuel pump, and generator field switch in ON position. Other switches may be placed ON as needed.

STOPPING ENGINE

There are six ways to stop the engine.

1. Press stop button on engine control panel No. 1 or No. 2.

When the locomotive is standing still or under power, the isolation switch should be placed in STOP position. The stop button can then be pressed in to stop the No. 1 or No. 2 engine as applicable. Since the reaction of the stop button is instantaneous, it need not be held in.

2. Press emergency fuel cutoff button.

Emergency fuel cutoff pushbuttons are located near each fuel filler opening and on the engine control panels. These pushbuttons operate in the same manner as the stop button and need not be held in nor reset. Any one of the emergency fuel cutoff switches will stop both engines in the locomotive.

3. Use layshaft lever.

The layshaft lever at the accessory end of the engine can be operated to override the engine governor and move the injector racks to the no fuel position.

4. Close the low water detector test cock.

When the low water detector trips, oil is dumped from the governor low oil shutdown device, stopping the engine.

5. Use throttle lever.

To stop all engines "on the line" in a consist simultaneously from the cab of the lead unit, move the throttle to IDLE position, pull the lever out and away from the controller, and move it beyond IDLE to the STOP position.

6. Pull out low oil shutdown rod on the side of the governor.

NOTE: Observe freezing weather precautions whenever an engine is shut down during cold weather.

SECURING LOCOMOTIVE FOR LAYOVER

1. Place the reverse lever in neutral position and the throttle in IDLE.
2. Place the selector lever in the OFF position and remove the reverse lever from controller.
3. Place isolation switch in START and press stop button IN.
4. Place all switches on the controller panel in the OFF position (down).
5. Place all circuit breakers and switches on the circuit breaker panel and the engine control panel in the OFF position and open all knife switches.

NOTE: Main battery switch and turbo lube oil pump circuit breaker must remain on for 35 minutes after load operation at throttle No. 3 or above.

6. Apply hand brake and block wheels, if necessary.

7. Cover exhaust stack if there is danger of a severe rain.
8. Drain or otherwise protect engine and cab heaters if there is danger of freezing. See Fig. 3-7.

TOWING LOCOMOTIVE IN TRAIN

When a locomotive unit equipped with 26L air brakes is placed within a train consist to be towed, its control and air brake equipment should be set as follows:

1. Drain all air from main reservoirs and air brake equipment unless engine is to remain idling.
2. Place the MU valve in DEAD position.
3. Place cutoff valve in CUT OUT position. 4. Place independent brake valve handle in release position.
5. Place automatic brake valve handle in handle off position.
6. Cut in dead engine feature by turning cutout cock, Fig. 2-9, to open (90° to pipe) position. Dead engine cock is located beneath cab floor and maybe reached through an access door at side of locomotive.

CAUTION: The pressure regulator shown in Fig. 2-9 is adjusted at a maintenance point in accordance with the type of brake equipment used. The locomotive operator should not attempt to adjust braking pressure.

7. If engine is to remain IDLING, switches should be positioned as follows:
 - a. Isolation switch in START position.

OPERATION

- b. All knife switches CLOSED.
 - c. Local control and control circuit breakers ON.
 - d. Generator field and starting fuses should be removed. Other fuses should be left in place.
 - e. Control and fuel pump switch ON.
 - f. Fuel pump circuit breaker ON.
 - g. Throttle in IDLE, selector in OFF, reverse lever in NEUTRAL. REMOVE REVERSE LEVER FROM CONTROLLER to lock controls.
8. If locomotive is to be towed DEAD in a train, switches should be positioned as follows:
- a. All knife switches OPEN.
 - b. All circuit breakers OFF.
 - c. All control switches OFF.
 - d. Starting fuse removed.
 - e. Throttle should be in IDLE, selector in OFF. REVERSE LEVER SHOULD BE REMOVED FROM CONTROLLER.

NOTE: If there is danger of freezing, the engine cooling system should be drained. See Fig. 3-7.

FREEZING WEATHER PRECAUTIONS

As long as the diesel engine is running, the cooling system will be kept adequately warm regardless of ambient (outside)

OPERATION

(temperatures encountered. It is only when the engine is shut down or stops for any reason that the cooling system requires protection against freezing. Perform the following to drain the engine cooling system.

1. Open the cab heater supply and return valves, Fig. 3-7, at the base of the equipment rack.
2. Open the main cooling system drain valve.
3. Open both cab heater drain valves.
4. Open fuel preheater drain valve.
5. In the locomotive cab, place the cab heater shutoff valve in the ON position.

NOTE: It is not necessary to open any water tank plugs or caps to facilitate draining.

SECTION 4

OPERATOR'S RESPONSE TO TROUBLE

INTRODUCTION

This section covers operational problems that may occur on the road and suggests action that may be taken by the operator in response to the trouble.

Safety devices automatically protect equipment in case of faulty operation of almost any component. In general this protection is obtained by one of the following methods.

1. Complete shutdown of the diesel engine, or complete elimination of a function such as dynamic braking.
2. Unloading of the diesel engine and restriction to slower or idle engine speed. In some instances manual resetting of the function may be necessary, or automatic resetting after a time delay may be provided.
3. Rough back-up regulation for protection of equipment, while allowing the locomotive to move under its own power to a point where maintenance service is available.

Condition	Probable Cause	Suggested Operator's Response
<p>Alarm bell rings - No alarm lights on in lead unit.</p> <p>1. No loss of power or only slight loss of power felt.</p> <p>2. Loss of power felt.</p>	<p>Trailing unit hot engine.</p> <p>Trailing unit reduced to idle speed and power or shut down.</p>	<p>No action required unless alarm persists. If alarm continues for more than a few minutes, investigate the cause of the alarm in trailing units.</p> <p>No action for 10 seconds; then press the ground relay reset pushbutton on the control stand if so equipped. In any case, if the alarm does not stop within a few minutes, investigate the cause of the alarm in trailing units.</p>

Condition	Probable Cause	Suggested Operator's Response
<p>Auto. Water Drain light on.</p> <p>Circuit Interrupter Trip light on. Alarm bell rings.</p> <p>(High Voltage Ground/Fault light may also come on.)</p>	<p>Engine shut down during freezing weather.</p> <p>Traction motor flash-over.</p>	<p>Make certain that the cab heater ON/OFF valves are in the ON position.</p> <p>If the light comes on and the engine is not shut down, immediately isolate the unit and investigate cooling system condition.</p> <p>No action required by the operator. Do not reduce throttle.</p> <p>After about 1/2 minute, the Circuit Interrupter Trip light will go out and power will be restored automatically.</p> <p>If the High Voltage Ground/Fault light came along with the Circuit Interrupter Trip light, the High Voltage Ground/Fault light will go out about 15 seconds before the interrupter trip light goes out.</p>

Condition	Probable Cause	Suggested Operator's Response
<p>High Voltage Ground/Fault light on. Alarm bell rings.</p>	<p>Traction motor flash-over.</p> <p>High voltage path to ground due to moisture or insulation failure.</p> <p>Five AR12 rectifier fuses in a single group blown.</p>	<p>After 10 seconds, press the ground relay reset button on the control stand if so equipped. The light will go out and power will be restored.</p> <p>This will occur automatically on units so equipped. Same response as above. If ground relay trip repeats only at high speed, temporary operation at lower throttle position may help to dry out the grounding circuit.</p> <p>Same response as above. In this case the ground relay cannot be reset. Isolate the unit.</p>

Condition	Probable Cause	Suggested Operator's Response
<p>Load Test light on.</p> <p>Turbocharger Auxiliary Pump light ON.</p> <p>No power light on; alarm ringing. No other lights on.</p>	<p>Load test switch in load test position.</p> <p>Normal condition for 35 minutes after engine start or engine stop.</p> <p>Engine shut down. Control switches set up for operation.</p> <p>Engine Overspeed.</p>	<p>CAUTION: DO NOT OPERATE THE UNIT. SERIOUS DAMAGE TO EQUIPMENT WILL OCCUR.</p> <p>Isolate the unit.</p> <p>No action necessary.</p> <p>Isolate the unit. Test auxiliary generator fuses. Replace if necessary. Restart engine.</p> <p>Reset overspeed trip lever. Restart engine. If trip occurs again, operation at lower throttle position may prevent further trip.</p>

Condition	Probable Cause	Suggested Operator's Response
<p>No Power light on; engine running; alarm ringing; unit will not load.</p> <p>Hot Engine light on; alarm ringing.</p>	<p>AR12 field fuses blown.</p> <p>D14 field fuses blown.</p> <p>Tunnel or desert operation.</p>	<p>Test fuses; Replace if necessary.</p> <p>Test fuses; Replace if necessary.</p> <p>No action necessary unless alarm continues for more than a few minutes.</p> <p>If alarm continues, isolate the affected unit. If water level is too low, shut the engine down.</p> <p>If freezing conditions are possible, drain the cooling system by opening 5 valves at the equipment rack sump and by opening the cab heater ON/OFF valve. See Fig. 3-7.</p>

Condition	Probable Cause	Suggested Operator's Response
<p>Hot oil, Low oil, Crankcase pressure, Low water light on. Engine shut down.</p>	<p>Low water due to leak, or low oil due to leak, or crankcase pressure due to cracked piston or bad cylinder seals, or hot oil due to plugged oil cooler.</p>	<p>If shutdown is due to low water, the addition of water may enable continued operation. Otherwise place the isolation switch in isolate position. Drain the cooling system if freezing conditions are possible.</p>
<p>WARNING: If the engine is restarted, shut it down immediately if oil pressure at idle is less than 15 psi.</p> <p>If crankcase pressure detector has tripped, make no further engineroom inspections. Do not attempt to restart the engine. Isolate the unit and drain the cooling system in accordance with railroad regulations.</p>		
<p>Repeated automatic sanding along with load current indicating meter dropping back.</p>	<p>Normal wheel slip correction under severe conditions.</p>	<p>No action required. Do not reduce throttle unless slipping is so severe that lurching threatens to break the train.</p>

Condition	Probable Cause	Suggested Operator's Response
Intermittent wheel slip light indications.	Normal wheel slip correction under severe conditions.	<p>No action required. Do not reduce throttle unless slipping is so severe that lurching threatens to break the train.</p> <p>If the unit is so equipped, place the lead truck sanding switch in the on position while climbing the hill.</p> <p>If the unit is so equipped, place the lead unit power reduction switch in the on position and slightly reduce lead unit power to enable it to dress the rail without slipping.</p>

Condition	Probable Cause	Suggest Operator's Response
<p>PCS light on.</p> <p>Brake Warning Light.</p>	<p>Penalty, or emergency brake application.</p> <p>Regulating system failure.</p>	<p>Train stopped; reverser centered; throttle 5 engine operation to pump up brakes; return throttle to idle.</p> <p>Place dynamic brake cutout switch on engine control panel of affected unit in the OFF position. If desired, and only DDA40X or later model units are in the consist, dynamic brake operation may continue with BWR providing dynamic brake regulation, but train handling will be rough.</p>